

# elco



## N

**N10.12000.37 GL-EUF**



## INNOVATION

Since its foundation in 1928, ELCO has always been a specialist in burners conception and manufacturing. By linking a strong innovative ability to a continued developing drive, ELCO has designed high performing and reliable burners as well as corresponding services throughout the years, and is today one of the leaders in the field of combustion technology.



## RESEARCH AND DEVELOPMENT

ELCO always looks for the best technologies and continues to develop new ones to improve the efficiency of its solutions.

Our R&D Laboratories are committed to develop innovative technological solutions allowing to:

- optimise the running of the installations lowering costs;
- offer service friendly products easy to maintain;
- preserve the environment lowering acoustic and pollutant emissions.



## OUR PRODUCT RANGE

Our experience at combustion technology available in a complete range of burners from 11 kW to 80 MW:



**VECTRON**  
11 - 2300 kW

**PROTRON**  
17 - 550 kW

**NEXTRON**  
250 - 11200 kW

**EK EVO**  
250 - 13500 kW

**N**  
1300 - 22000 kW

# CUTTING-EDGE BURNERS FOR HEATING AND INDUSTRIAL APPLICATIONS

## KNOW-HOW

Your contacts at ELCO and its partners are recognised experts with years of experience. Our worldwide support starts from concept creation to planning, design and project management up to commissioning and on-going operation of the plant throughout its life cycle. As an ELCO customer, you can rely on your installation to perform reliably. Our guarantee is backed up by a service that sets standards in our field.



## WORLDWIDE NETWORK

Capitalising on more than 90 years of work experience, ELCO has been capable to build up loyal partnerships and today can count on reliable Partners all over the World. Combining an instinctively global perspective with a genuinely multicultural approach ELCO today offers you skilled and experienced experts available in more than 70 Countries.

### In Europe

3 production plants  
6 commercial branches  
Strong commercial presence through a network of reliable dealers and partners

### Worldwide

2 Sales Offices in Russia and China  
Distribution in over 70 Countries



**HO/GHO-TRON**  
68 - 17000 kW

**RPD**  
500 - 80000 kW

**EK-DUO**  
600 - 16000 kW

**D-TRON**  
230 - 34000 kW

# MONOBLOCK

# N



## Monoblock burners from 1300 kW to 22000 kW in gas, light oil and dual fuel

- Thanks to innovative and weight-saving technologies, the N range is an optimal choice wherever compact solution and high power outputs are needed. The key feature is the physical division of the burner into a support frame and a separate air-routing housing

- With the introduction of the new N11 burner model and the innovative solutions of this range, ELCO can now provide high performance and ease of use on its monoblock range up to 22 MW

 NATURAL

 DUAL FUEL

 LIGHT OIL

### All N burners feature:

- built-in or external control box, according to customer requirements
- secured burner head adjustments during maintenance (RTC System)
- closing of the air damper on burner shut-down
- products are in compliance with EN676 and EN267 European standards and with the following directives: 2014/35/EU Low Voltage Directive, 2014/30/UE EMC Directive, 2016/426/UE Gas Appliances Directive, 2006/42/EC Machinery Directive, 2011/65/EU RoHS2 Directive

# N\_N10.12000.37 GL-EUF



- Operation: two stage progressive/modulating electronic in gas and in oil;
- Emission class: Low NOx class 3 in gas (<80 mg/kWh) according to EN676, Low NOx class 3 (<120 mg/kWh) according to EN267 in light oil

## WORKING DIAGRAM

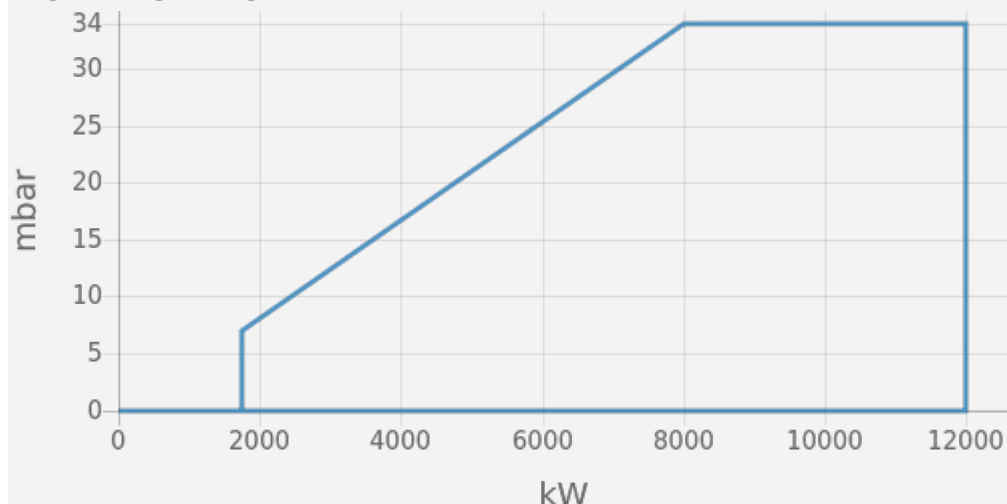

## TECHNICAL DATA

|                           |       |
|---------------------------|-------|
| Minimum power output (kW) | 1750  |
| Maximum power output (kW) | 12000 |
| Fan motor (kW)            | 37    |
| Protection level          | IP41  |

## OVERALL DIMENSIONS

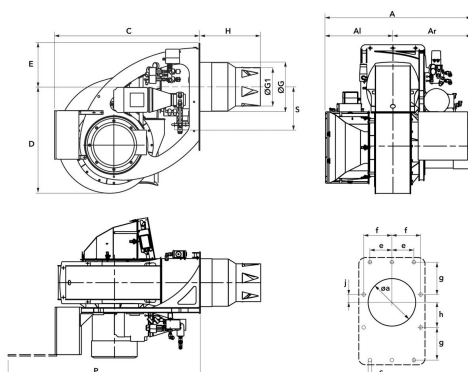

| AI  | Ar  | A    | C    | D    | E   | G   | G1  | H   | P    | S   | Øa  | c   | e   | f   | g   | h   | j  |
|-----|-----|------|------|------|-----|-----|-----|-----|------|-----|-----|-----|-----|-----|-----|-----|----|
| 683 | 758 | 1441 | 1494 | 1095 | 450 | 504 | 396 | 600 | 2094 | 446 | 525 | M20 | 230 | 290 | 345 | 275 | 70 |

## Subsidiaries ELCO

### GERMANY

ELCO GmbH  
Dreieichstraße 10  
Mörfelden-Walldorf  
Tel.: +49 (0) 6105 287-287  
Fax: +49 (0) 6105 287-199

### NETHERLANDS

Elco Burners B.V.  
Meerpaalweg, 1  
1332 BB Almere  
P.O. box 30048  
1303 AA Almere  
Tel. +31 088 69 573 11  
Fax +31 088 69 573 90

### FRANCE

14, rue du Saule Trapu  
Parc d'activité du Moulin  
91882 Massy  
Tel. +33 01 60 13 64 64  
Fax +33 01 60 13 64 65

### SWITZERLAND

Elcotherm AG  
Sarganserstrasse 100  
7324 Vilters  
Tel. +41 (0)81 725 25 25  
Fax +41 (0)81 723 13 59

### AUSTRIA

ELCO Austria GmbH  
Aredstraße 16 - 18  
2544 Leobersdorf  
Tel. +43 (0)2256 639 99 32  
Fax +43 (0)2256 644 11

### ITALY

Via Roma, 64  
31023 Resana (TV)  
Tel. +39 0423 719500  
Fax +39 0423 719580

### UK & IRELAND

Ariston Thermo UK Ltd  
Suite 3, The Crown House  
Blackpole East, Blackpole Road,  
Worcester WR3 8SG  
Tel. +44 01905 788010  
Fax +44 01905 788011

### RUSSIA

Ariston Thermo RUS  
Eniseyskaya str. 1, bld 1,  
Office Center "LIRA" #438  
129344 Moscow  
Tel. +7 495 213 0300 #5700  
Fax +7 495 213 0302

### CHINA

Ariston Thermo (China) Co., Ltd.  
F/15, V-Capital Bldg  
No. 333 Xian Xia Road  
200336 Shanghai  
Tel. +86 21 6039 8691  
Fax +86 21 6039 8620

Contact us to know more  
about our products and solutions

[www.elco-burners.com](http://www.elco-burners.com)  
[contact@elco-burners.com](mailto:contact@elco-burners.com)