

elco

INDUSTRY CATALOGUE





INDUSTRY CATALOGUE

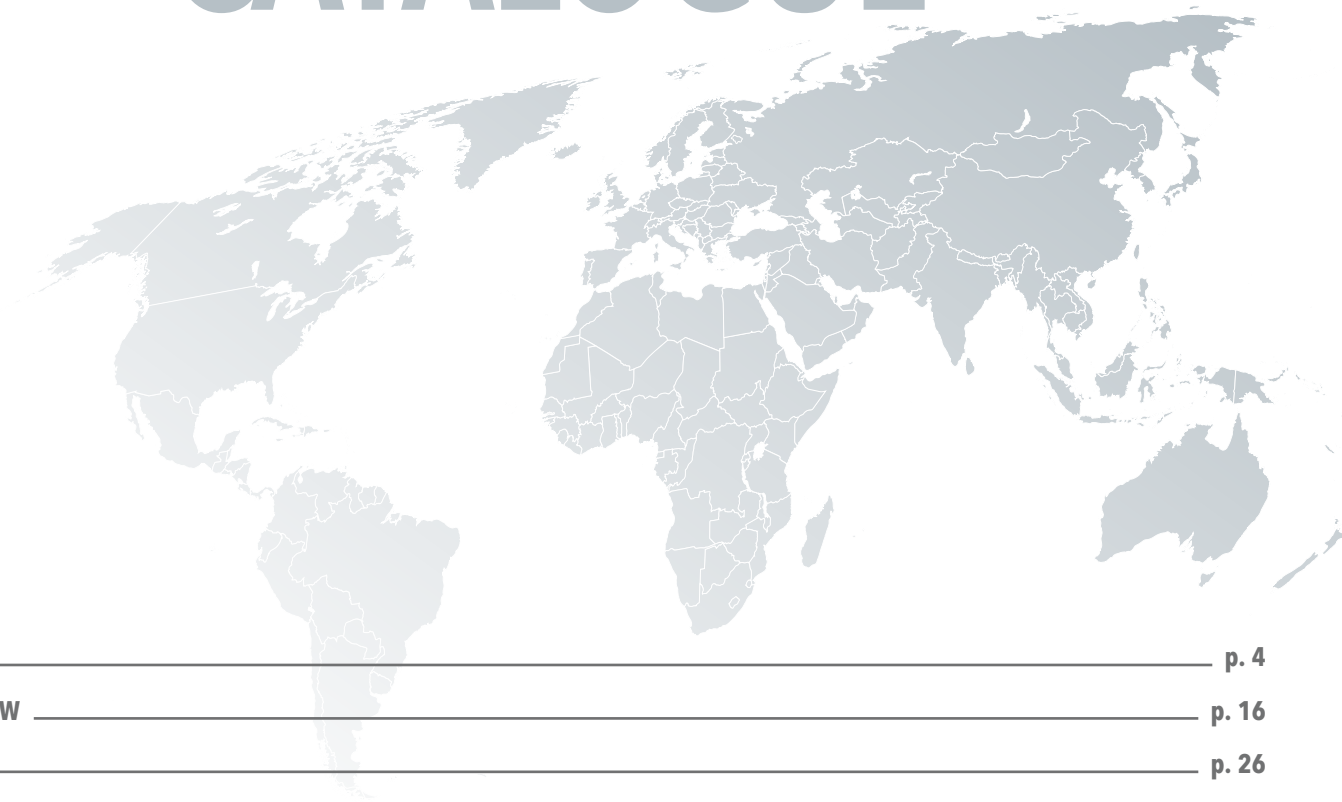

THE COMPANY	p. 4
RANGE OVERVIEW	p. 16
EK EVO RANGE	p. 26
NEXTRON RANGE	p. 94
N RANGE	p. 142
HO-TRON RANGE	p. 166
GHO-TRON RANGE	p. 186
DUOBLOCK RANGE	p. 198
GAS TRAINS	p. 206
OPTIONS AND ACCESSORIES	p. 211



CUTTING-EDGE BURNERS FOR HEATING AND INDUSTRIAL APPLICATIONS

INNOVATION

Since its foundation in 1928, ELCO has always been a specialist in burners conception and manufacturing. By linking a strong innovative ability to a continued developing drive, ELCO has designed high performing and reliable burners as well as corresponding services throughout the years, and is today one of the leaders in the field of combustion technology.



OUR MISSION

ELCO always looks for the best technologies and continues to develop new ones to improve the efficiency of its solutions.

Our R&D Laboratories are committed to develop innovative technological solutions allowing to:

- optimise the running of the installations lowering costs;
- offer service friendly products easy to maintain;
- preserve the environment lowering acoustic and pollutant emissions.



OUR KNOWLEDGE

Your contacts at ELCO and its partners are recognised experts with years of experience. Our worldwide support starts from concept creation to planning, design and project management up to commissioning and on-going operation of the plant throughout its life cycle.

As an ELCO customer, you can rely on your installation to perform reliably. Our guarantee is backed up by a service that sets standards in our field.



PROFESSIONAL STAFF

Taking advantage of a staff composed of technicians and engineers with a long experience, ELCO is able to provide professional support to the customer in order to define together the best solution and to develop and manage the project through its entire life-cycle.

ELCO Service activities define the standards in the market and each customer can rely on high performance and reliable products.



SOLUTIONS FOR EVERY NEED

A long presence in the international market has allowed ELCO to build a strong experience in burner customization and to develop products that are able to guarantee reliability, quality and high performance even in the most extreme working conditions.



TECHNICAL ASSISTANCE

For safe and efficient operation of your burner system it is very important that the burner is commissioned by a competent person. The combustion will be optimally adjusted over the whole power range of the burner, and all the safety devices will be tested. To keep your installation in good conditions, it is important to maintain the burner periodically. It is also very important to inspect all the safety devices to ensure that your system operates safely. Fortunately, you can rely on the professional services of ELCO which can perform this service for you.



BURNER ACADEMY

In order to respond to the needs of our customers we created a Burner Academy, a real training school where the knowledge of our technicians is passed on to our trainees. We provide the opportunity for boiler room personnel, operators and engineers to attend a series of training sessions carried out on our test bench by highly qualified instructors, who hold the courses in English, German, French, Italian and Dutch language.

The Burner Academy uses various training locations where boilers are installed and where people can be trained in theory and in practice. We offer courses at different levels and also the possibility to handle all your needs in a customer-specific training.



RELIABLE SUPPLY OF SPARE PARTS

Spare parts have always had a great importance inside the ELCO world. Considering the high amount of parts involved in every single product, some of these parts might naturally need to be replaced. ELCO can count on an International network offering original spare parts in order to guarantee the highest quality, reliability and safe continued operation of the appliance.

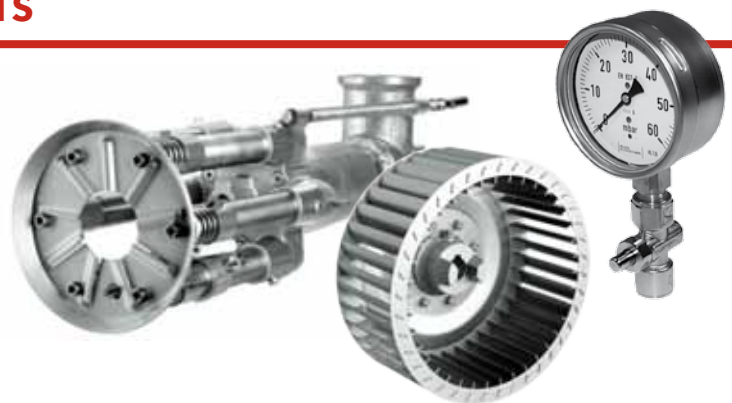

WORLDWIDE NETWORK

Capitalising on more than 90 years of work experience, ELCO has been capable to build up loyal partnerships and today can count on reliable Partners all over the World.

Combining an instinctively global perspective with a genuinely multicultural approach ELCO today offers you skilled and experienced experts available in more than 70 Countries.

In Europe

3 production plants
6 commercial branches
Strong commercial presence through a network of reliable dealers and partners

Worldwide

2 Sales Offices in Russia and China
Distribution in over 70 Countries

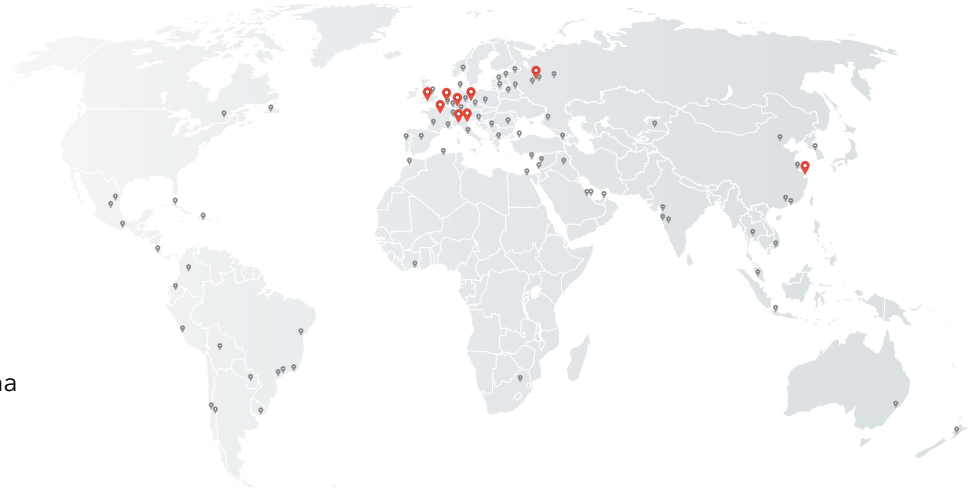

Service Network

In Western Europe, ELCO has a well organised service network. Outside Western Europe ELCO uses a network of partners, consisting of well-trained local engineers, to carry out its service operations. These technicians are able to perform both commissioning and local service and they do it in a very professional and efficient way.

ELCO ON THE WEB

We are constantly looking forward to provide to our customers new technologies, products and services. Stay always up to date on the latest news from the ELCO World visiting our website:

www.elco-burners.com

Navigate to explore the ELCO proposal and choose the perfect product to fit your needs, and follow us to know more about our new activities and projects.

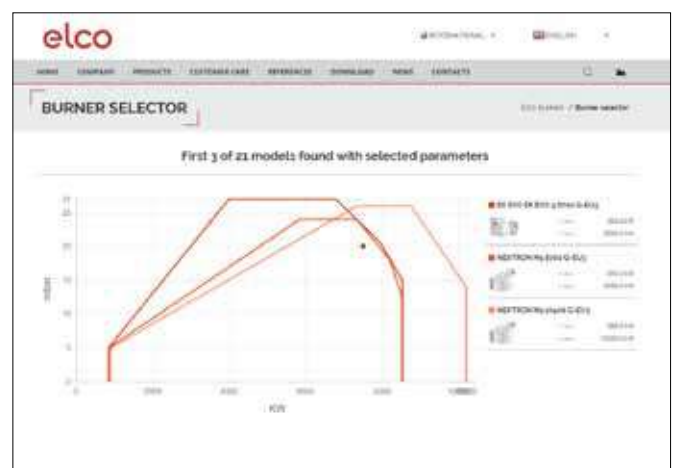
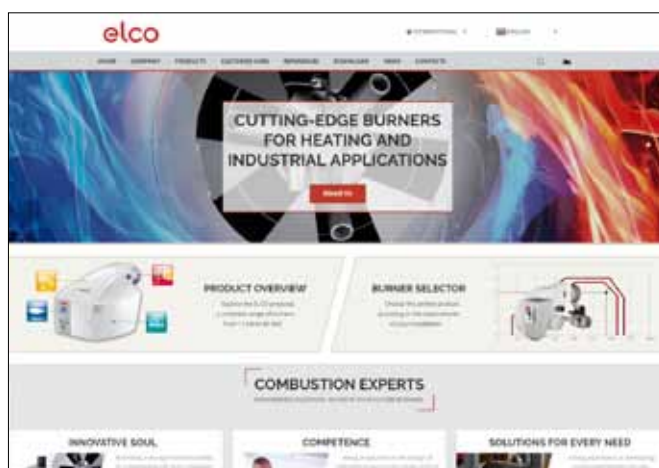

OUR PRODUCT RANGE

Our experience at combustion technology available in a complete range of burners from 11 kW to 80 MW:

Monoblock range:



VECTRON
11 - 2300 kW
■ Gas
■ Light oil
■ Dual fuel



PROTRON
15 - 550 kW
■ Gas
■ Light oil



NEXTRON
250 - 11200 kW
■ Gas
■ Light oil
■ Dual fuel



EK EVO
250 - 13500 kW
■ Gas
■ Light oil
■ Dual fuel



N
1300 - 22000 kW
■ Gas
■ Light oil
■ Dual fuel



HO-TRON
68 - 17000 kW
■ Heavy oil



GHO-TRON
414 - 17000 kW
■ Heavy oil
■ Dual fuel

Duoblock range:



D-TRON
230 - 34000 kW
■ Gas
■ Light oil
■ Gas / light oil
■ Heavy oil
■ Gas / heavy oil



EK-DUO
600 - 16000 kW
■ Gas
■ Light oil
■ Dual fuel



RPD
500 - 80000 kW
■ Gas
■ Light oil
■ Gas / light oil
■ Heavy oil
■ Gas / heavy oil

ELCO SYSTEMS AND TECHNOLOGIES

To constantly improve its products, ELCO is committed to develop innovative technological solutions allowing to optimise the running of the installations, to ease technicians work, and naturally to preserve the environment. In order to provide quick responses to its market's demands, the range of ELCO burners is entirely conceived around a consistent combination of Systems.



MDE2 System

Permanent communication of information easy to use

Equipped with the MDE2 System, the universal language Elcogram and the 5-button keyboard, ELCO burners adjust themselves and constantly communicate to the technicians and operators:

- real time information about each ignition and during the running;
- statistical information about the burner operations recorded during the whole year before the maintenance operations.

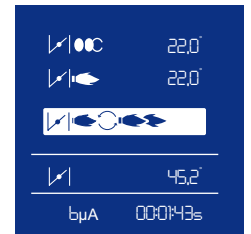
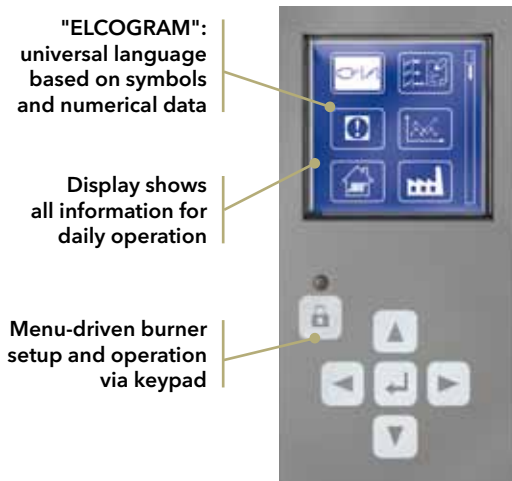

Elcogram, a universal language

As ELCO products are distributed worldwide, the company has developed a universal language composed of pictograms and numerical data. The pictograms use the majority of the symbols used on the wiring diagrams which are recognised and understood by all Nations. This ensures that information is easier to read than ever before.



CMS System

The evolution of combustion management systems

CMS is a brand new system for burner management that sets new standards in control automation. The system provides a full combustion management solution that meets all relevant safety standards, and is certified for all main markets and Standards. CMS system is simple and easily configurable to meet a wide range of application requirements, from low cost to high end solutions, for industrial or residential applications.

The CMS grants efficient communication via BUS and is extremely flexible due to the fact that is fully configurable, fully compatible with external devices/systems and fully scalable, allowing additional functions, such as VSD fan control, oxygen trim and CO control.

A wide number of interfaces are available, from low-cost keypad to high-resolution touchscreens, allowing intuitive and easy interaction between user and machine.



ELCO SYSTEMS AND TECHNOLOGIES



AGP System

An outstanding technology for gas burners

Developed and produced by ELCO, the AGP System (proportional air-gas) provides:

- perfect stability of the air-gas mixture;
- a constantly high CO₂ content over the whole burner power range;
- precise control of air excess, which is important for high-efficiency operation, in particular for condensing generators.

The AGP measures: the gas pressure downstream of the gas train, the air pressure behind the flame holder and the furnace backpressure.

Any variations in the three pressures are immediately and simultaneously recorded by the system which automatically restores the correct gas/combustion air ratio.

AGP maintains a constant gas/combustion air ratio even in the presence of:

- positive or negative variations in the gas pressure;
- variations in air flow due to changes in the electrical supply voltage or fouling of the ventilation system;
- variations in the furnace and flue draft pressure on start-up and during load changes.



GEM System

Electronic burner control: high safety and low costs

The use of electronic technologies in burner control systems helps to reduce running costs, improve reliability of operation and lower pollutant emissions. The electronic combustion manager used on ELCO burners are responsible not only for the burner control (formerly the task of the traditional automatic combustion control unit) but also for fuel/air regulation. Data stored electronically has replaced the mechanical characteristic curve and help to achieve an unprecedented level of precision in air/fuel ratio regulation across the burner's entire control range, a prerequisite for efficient, energy- and cost-saving operation.

The GEM System controls the position of one or more activators simultaneously. The servomotors of the air flow and oil components are controlled by a microprocessor which contains set points defined for each load curve. An additional advantage of the GEM is that it provides specific information on all the commands and current situation of the overall system: these can be accessed directly or by remote control.

The digital programming is user-friendly, it is carried out through the display of the MDE2 System or through a PC by using a simple procedure facilitated by easy instructions in a clear language.



Variatron

Speed regulation: noise reduction and energy saving

To improve the performance of heating or industrial systems, ELCO applies Variatron (fan speed control). Conventionally, the air in modulating burners is regulated by an air flap. In the partial load range, a large amount of the air pressure generated by the ventilator goes to waste.

With speed regulation, the speed of the combustion-air fan is varied continuously depending on the burner output required. Full speed is reached only at maximum burner output. In the predominant partial load range, lower speed translates into significant reductions in power consumption and noise emissions. The Variatron operates in step with the air damper both with the GEM System and with the AGP System, which guarantees a combustion with minimum air excess by continuously monitoring all operating conditions.

Application of the Variatron to ELCO burners results in:

- electrical consumption savings in the order of 50%;
- turndown ratio of up to 1:10, resulting in perfect adaptation to system requirements and improvement in average seasonal efficiency, in particular with condensing or low-temperature boilers or specific processes;
- silent start-up and average overall noise reduction between 2 dB(A) (at maximum power) and 12 dB(A) (at minimum power).

COMBUSTION TECHNOLOGIES



Diamond Head Low emissions and reliable operation

The principle of the Diamond Head combustion technology is based on the internal recirculation of the combustion flue gases. These are partially drawn into the base of the flame via triangular openings positioned at the end of the combustion head. The position and geometry of the gas injectors are such that a significant quantity of combustion flue gas is drawn in and rapidly mixed with air and gas at the root of the flame.

This mixture crosses the main reaction area, slowing the combustion, which in turn results in lowering the main flame temperature. The result of this staging combustion is a significant reduction in the formation of thermal nitrogen oxides.

The advantage of this internal recirculation technique is an automatic adjustment to the quantity of recycled combustion flue gases: the volume of the flame is always as low as possible, which has a very minor effect on the nominal power of the generator, unlike external recirculation systems.

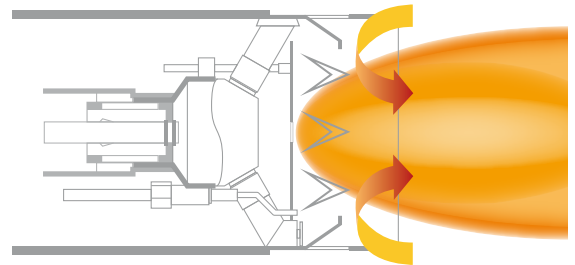

Free Flame The pinnacle of low-polluting burner engineering

The principle of the Free Flame oil combustion is based on rapid gasification of the fuel by recirculating the combustion gases internally and allows the fuel-air to mix quickly.

Once the fuel has been vaporised, it will burn and stabilise 30 centimetres from the combustion head.

The flame appears to “float freely” hence the name “Free Flame”. The heat absorbed by the gasification oil will cause a significant drop in the flame’s temperature and a decrease in the formation of the thermal nitrogen oxide.

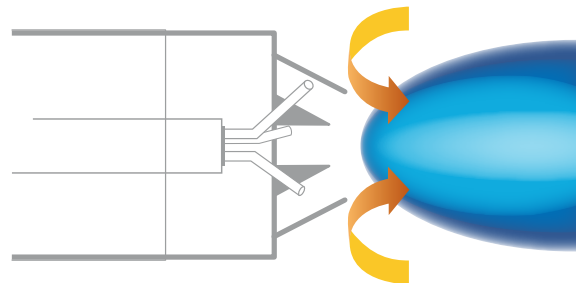

FGR System Ultra low NOx solutions to reach emissions of less than 30 mg/kWh

ELCO offers a wide range of products which use the external FGR technology to reduce NOx emissions and satisfy even the most stringent regulations.

The principle of external flue gas recirculation consists in sending a mixture of comburent air and flue gas to the combustion head, thus reducing the NOx emissions. The gases are mixed upline of the combustion process by the burner fan (for mono-block units) or by the external fan (in case of duoblock burners). This technology enables ELCO to guarantee emissions of less than 30 mg/kWh, a value which is hard to obtain with conventional combustion systems, and offer cutting-edge products which satisfy the requirements of any current regulations.

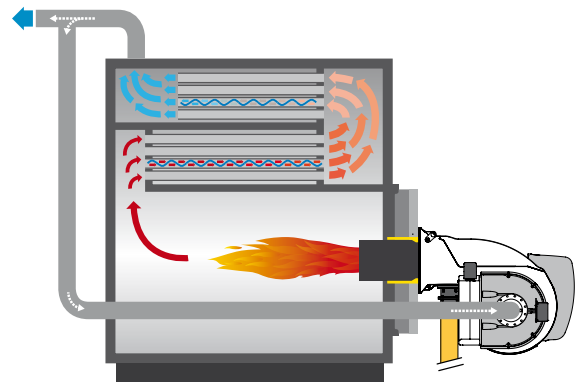

WORLDWIDE REFERENCES

ELCO has been chosen as the ideal partner from worldwide companies to design installations where technical specifications and environmental conditions require a specific design. In the next pages you will find a selection of our international references.



Beijing, China
4x RPD 100 G-EU



Sergiev Posad, Russia
2x N6.2900 G-R
2x N7.3600 G-R



Stuttgart, Germany
1x EK-DUO 2.550 GL-EUF
2x EK-DUO 2.700 GL-EUF



Beijing, China
2x N10.16000 G-EU2 FGR



Stavanger, Norway
2x EK-DUO 3.1600 G-E



Altchemnitz, Germany
6x N11.22000 G-EU1

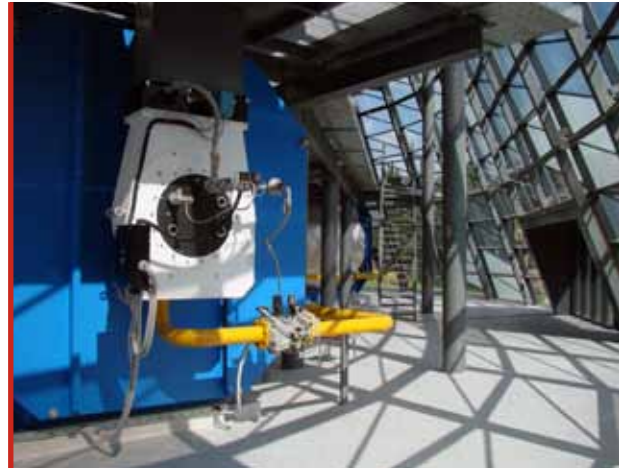

Saint Petersburg, Russia
1x EK-DUO 4.1600 G-EU2



Seoul, South Korea
7x N8.7100 G-EU3



Beijing, China
1x EK EVO 8.5800 G-EU3 FGR
2x EK EVO 8.7100 G-EU3 FGR



Tianjin, China
1x RPD130 G-EU1 FGR



Epe, Netherlands
1x EK EVO 7.4500 G-EF3

EK EVO and NEXTRON range

Burner body

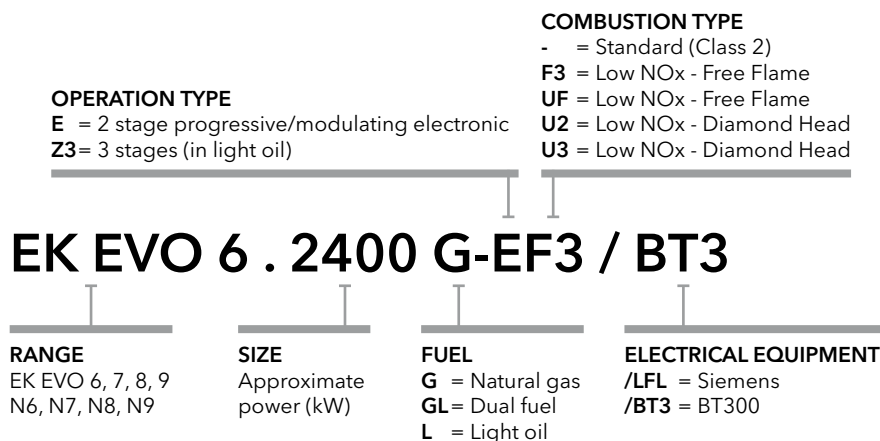

Combustion head

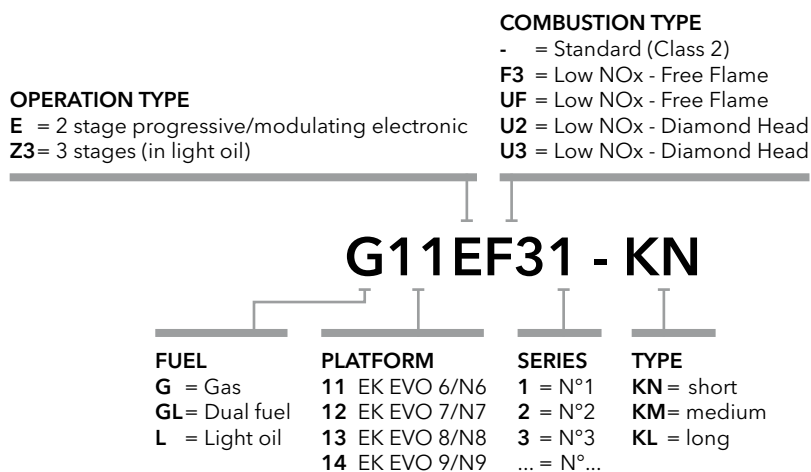

Gas train

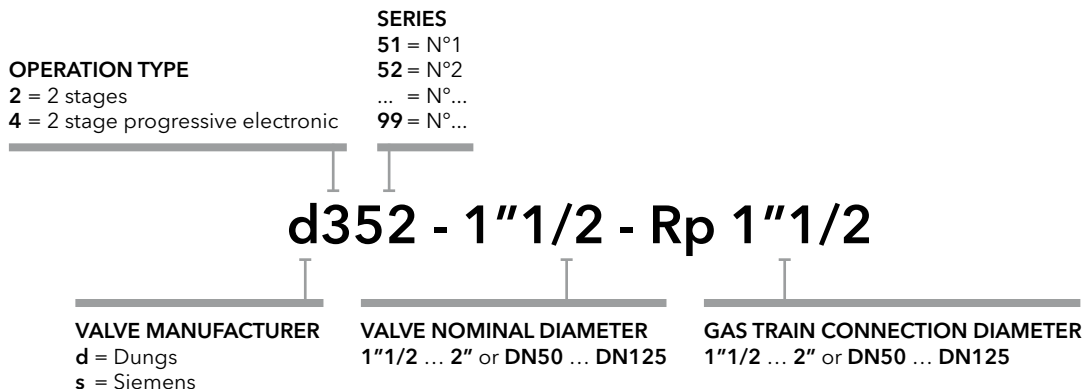

N range

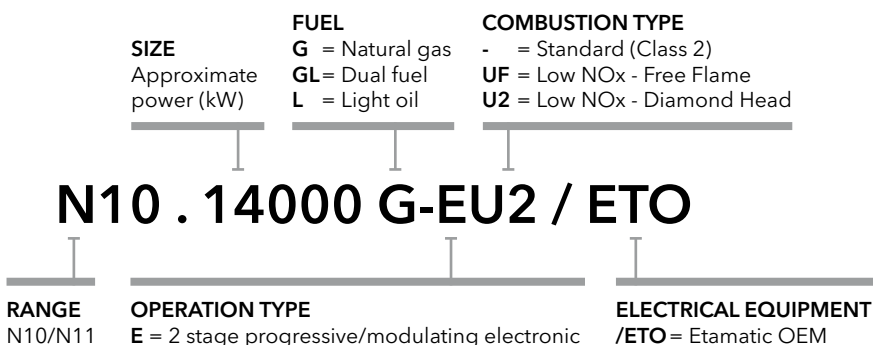

HO-TRON and GHO-TRON range

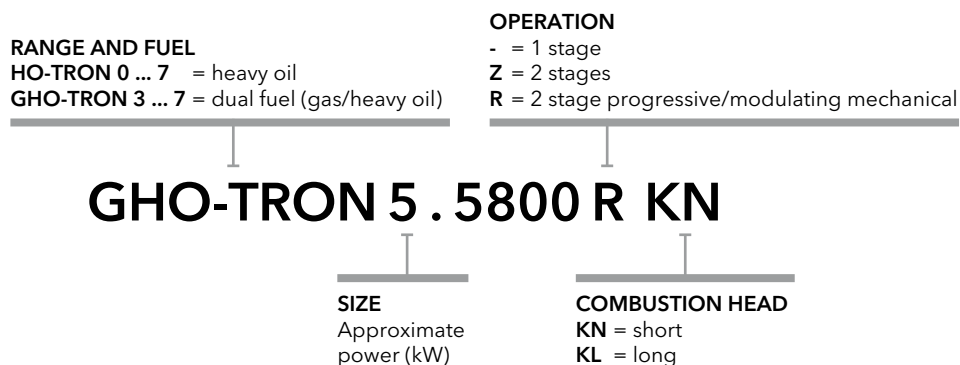

D...-TRON range

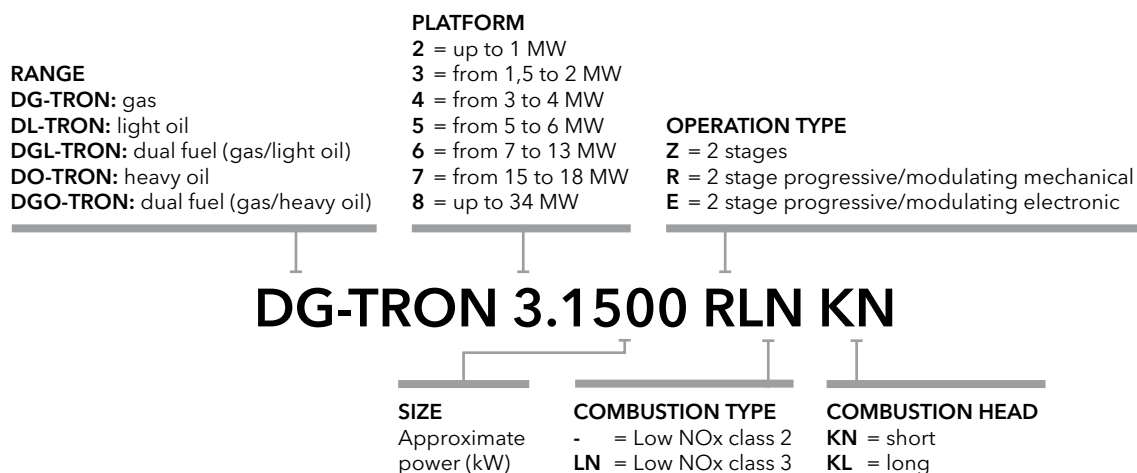

EK-DUO and RPD range

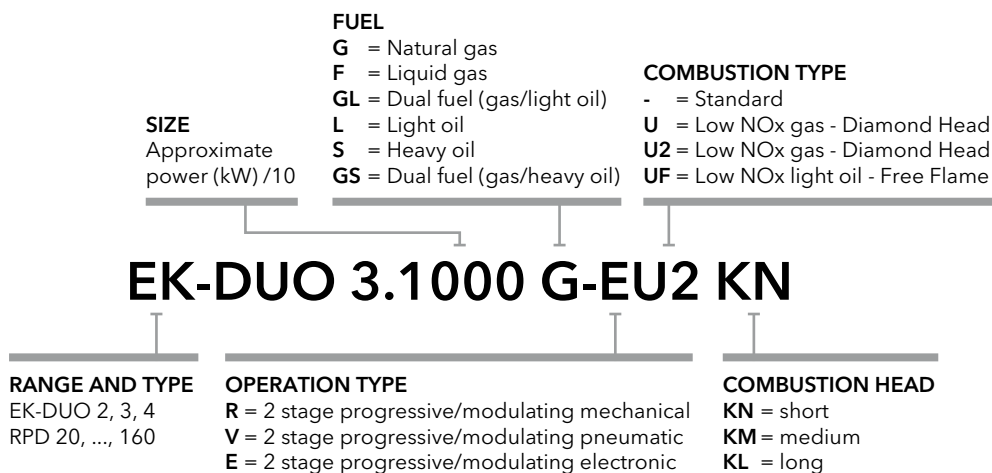

TWO STAGE PROGRESSIVE/MODULATING ELECTRONIC

EK EVO 6.2400 G-E	390 ... 2650 kW		p. 28
EK EVO 6.2900 G-E	400 ... 3200 kW		p. 28
EK EVO 7.3600 G-E	580 ... 4300 kW		p. 28
EK EVO 7.4500 G-E	680 ... 5400 kW		p. 28
EK EVO 8.5800 G-E	620 ... 6570 kW		p. 32
EK EVO 8.7100 G-E	610 ... 8150 kW		p. 32
EK EVO 9.8700 G-E	780 ... 9700 kW		p. 32
EK EVO 9.10400 G-E	850 ... 11230 kW		p. 32

0 2000 4000 6000 8000 10000 12000 kW

TWO STAGE PROGRESSIVE/MODULATING ELECTRONIC Low NO_x

EK EVO 6.2400 G-EF3	340 ... 2500 kW		p. 36
EK EVO 6.2900 G-EF3	340 ... 2900 kW		p. 36
EK EVO 7.3600 G-EF3	470 ... 3980 kW		p. 40
EK EVO 7.4500 G-EF3	510 ... 4290 kW		p. 40
EK EVO 7.5800 G-EF3	620 ... 5500 kW		p. 40
EK EVO 7.7000 G-EU3	610 ... 7450 kW		p. 44
EK EVO 8.5800 G-EU3	600 ... 6070 kW		p. 48
EK EVO 8.7100 G-EU3	700 ... 7700 kW		p. 48
EK EVO 9.8700 G-EU3	850 ... 8530 kW		p. 48
EK EVO 9.10400 G-EU3	910 ... 10500 kW		p. 48
EK EVO 9.13000 G-EU3	1350 ... 13500 kW		p. 52

0 3000 6000 9000 12000 15000 kW

EK EVO DUAL FUEL RANGE (GAS/LIGHT OIL)

TWO STAGE PROGRESSIVE/MODULATING ELECTRONIC IN GAS / THREE STAGES IN LIGHT OIL

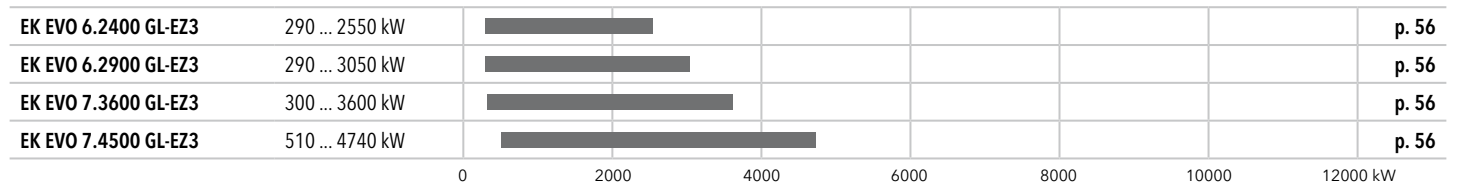

TWO STAGE PROGRESSIVE/MODULATING ELECTRONIC IN GAS AND IN LIGHT OIL

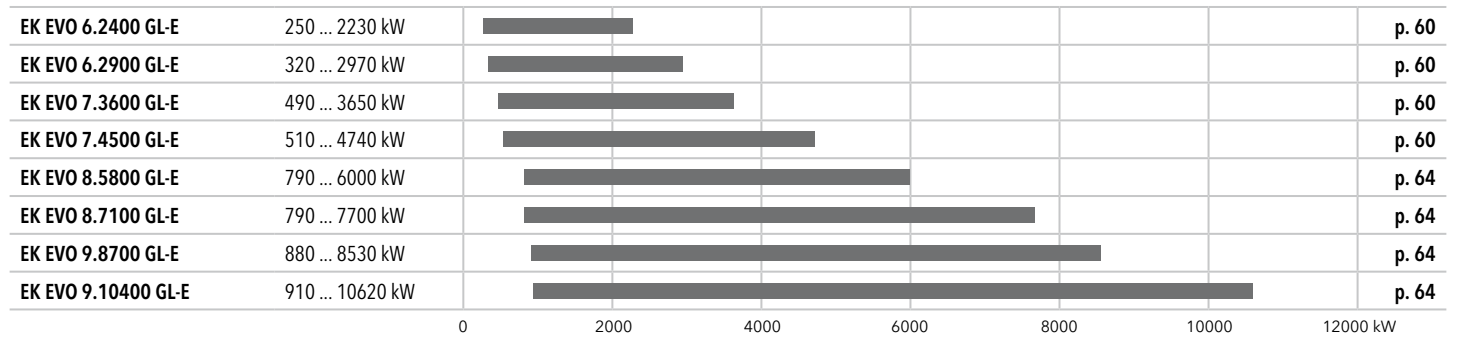

TWO STAGE PROGRESSIVE/MODULATING ELECTRONIC IN GAS AND IN LIGHT OIL Low NOx

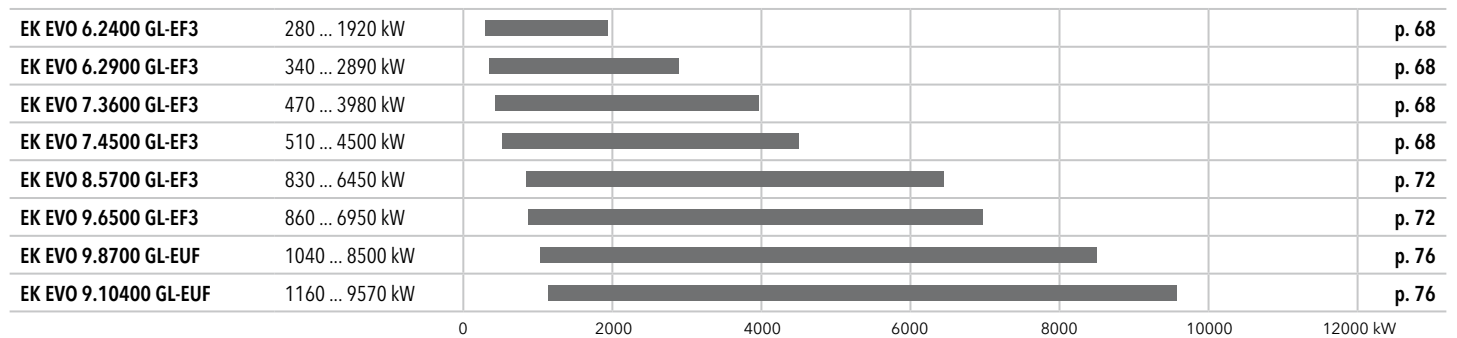

EK EVO LIGHT OIL RANGE

TWO STAGE PROGRESSIVE/MODULATING ELECTRONIC

EK EVO 6.2400 L-E	510 ... 2030 kW		p. 80
EK EVO 6.2900 L-E	650 ... 3100 kW		p. 80
EK EVO 7.3600 L-E	900 ... 3850 kW		p. 80
EK EVO 7.4500 L-E	1300 ... 4900 kW		p. 80
EK EVO 8.5800 L-E	1210 ... 6100 kW		p. 82
EK EVO 8.7100 L-E	1450 ... 7700 kW		p. 82
EK EVO 9.8700 L-E	2400 ... 8530 kW		p. 82
EK EVO 9.10400 L-E	2820 ... 10620 kW		p. 82

TWO STAGE PROGRESSIVE/MODULATING ELECTRONIC Low NOx

EK EVO 6.2400 L-EF3	360 ... 1850 kW		p. 84
EK EVO 6.2900 L-EF3	480 ... 2950 kW		p. 84
EK EVO 7.3600 L-EF3	680 ... 4070 kW		p. 84
EK EVO 7.4500 L-EF3	740 ... 4820 kW		p. 84
EK EVO 8.5700 L-EF3	1100 ... 6450 kW		p. 86
EK EVO 9.6500 L-EF3	1200 ... 6600 kW		p. 86
EK EVO 9.8700 L-EUF	1800 ... 8500 kW		p. 88
EK EVO 9.10400 L-EUF	2550 ... 9570 kW		p. 88









EK EVO OPTIONS

BURNER VARIANTS _____ p. 90

BURNER KITS _____ p. 92









SPECIAL CONFIGURATIONS _____ p. 93

TWO STAGE PROGRESSIVE/MODULATING ELECTRONIC

N6.2400 G-E	390 ... 2500 kW		p. 96
N6.2900 G-E	400 ... 3000 kW		p. 96
N7.3600 G-E	580 ... 4100 kW		p. 96
N7.4500 G-E	680 ... 5000 kW		p. 96
N8.5800 G-E	740 ... 6570 kW		p. 100
N8.7100 G-E	800 ... 7800 kW		p. 100
N9.8700 G-E	880 ... 9200 kW		p. 100
N9.10400 G-E	960 ... 11200 kW		p. 100

0 2000 4000 6000 8000 10000 12000 kW

TWO STAGE PROGRESSIVE/MODULATING ELECTRONIC Low NO_x

N6.2400 G-EF3	340 ... 2300 kW		p. 104
N6.2900 G-EF3	360 ... 2850 kW		p. 104
N7.3600 G-EF3	500 ... 3900 kW		p. 104
N7.4500 G-EF3	600 ... 4200 kW		p. 104
N8.5800 G-EU3	640 ... 5800 kW		p. 108
N8.7100 G-EU3	700 ... 7100 kW		p. 108
N9.8700 G-EU3	850 ... 8530 kW		p. 108
N9.10400 G-EU3	900 ... 10200 kW		p. 108

0 2000 4000 6000 8000 10000 12000 kW

NEXTRON DUAL FUEL RANGE (GAS/LIGHT OIL)

TWO STAGE PROGRESSIVE/MODULATING ELECTRONIC IN GAS AND IN LIGHT OIL

N6.2400 GL-E	250 ... 2230 kW		p. 112
N6.2900 GL-E	320 ... 2970 kW		p. 112
N7.3600 GL-E	490 ... 3650 kW		p. 112
N7.4500 GL-E	510 ... 4750 kW		p. 112
N8.5800 GL-E	800 ... 5350 kW		p. 116
N8.7100 GL-E	820 ... 7340 kW		p. 116
N9.8700 GL-E	880 ... 8530 kW		p. 116
N9.10400 GL-E	910 ... 10620 kW		p. 116

TWO STAGE PROGRESSIVE/MODULATING ELECTRONIC IN GAS AND IN LIGHT OIL Low NOx

N6.2400 GL-EF3	280 ... 1920 kW		p. 120
N6.2900 GL-EF3	340 ... 2890 kW		p. 120
N7.3600 GL-EF3	470 ... 3980 kW		p. 120
N7.4500 GL-EF3	510 ... 4500 kW		p. 120
N8.5700 GL-EF3	830 ... 6450 kW		p. 124
N9.6500 GL-EF3	830 ... 6950 kW		p. 124
N9.8700 GL-EUF	1040 ... 8500 kW		p. 124
N9.10400 GL-EUF	1160 ... 9570 kW		p. 124

NEXTRON

LIGHT OIL RANGE

TWO STAGE PROGRESSIVE/MODULATING ELECTRONIC

N6.2400 L-E	510 ... 2030 kW		p. 128
N6.2900 L-E	650 ... 3100 kW		p. 128
N7.3600 L-E	900 ... 3850 kW		p. 128
N7.4500 L-E	1300 ... 4900 kW		p. 128
N8.5800 L-E	1350 ... 5350 kW		p. 130
N8.7100 L-E	1470 ... 7340 kW		p. 130
N9.8700 L-E	2400 ... 8530 kW		p. 130
N9.10400 L-E	2820 ... 10620 kW		p. 130

TWO STAGE PROGRESSIVE/MODULATING ELECTRONIC Low NOx

N6.2400 L-EF3	360 ... 1850 kW		p. 132
N6.2900 L-EF3	480 ... 2950 kW		p. 132
N7.3600 L-EF3	680 ... 4070 kW		p. 132
N7.4500 L-EF3	740 ... 4820 kW		p. 132
N8.5700 L-EF3	1100 ... 6450 kW		p. 134
N9.6500 L-EF3	1200 ... 6600 kW		p. 134
N9.8700 L-EUF	1800 ... 8500 kW		p. 134
N9.10400 L-EUF	2550 ... 9570 kW		p. 134

NEXTRON

OPTIONS

BURNER VARIANTS _____ p. 136

BURNER KITS _____ p. 139

SPECIAL CONFIGURATIONS _____ p. 141

RANGE OVERVIEW

N GAS RANGE

TWO STAGE PROGRESSIVE/MODULATING ELECTRONIC

N10.12000 G-E	1300 ... 12000 kW		p. 144
N10.14000 G-E	1750 ... 14000 kW		p. 144
N10.16000 G-E	2000 ... 16000 kW		p. 144

TWO STAGE PROGRESSIVE/MODULATING ELECTRONIC Low NOx

N10.12000 G-EU2	1500 ... 12000 kW		p. 148
N10.14000 G-EU2	1750 ... 14000 kW		p. 148
N10.16000 G-EU2	2000 ... 16000 kW		p. 148
N11.19000 G-EU2	2750 ... 19000 kW		p. 152
N11.22000 G-EU2	2750 ... 22000 kW		p. 152

N DUAL FUEL RANGE (GAS/LIGHT OIL)

TWO STAGE PROGRESSIVE/MODULATING ELECTRONIC IN GAS AND IN LIGHT OIL

N10.12000 GL-E	1300 ... 12000 kW		p. 156
----------------	-------------------	--	--------

TWO STAGE PROGRESSIVE/MODULATING ELECTRONIC IN GAS AND IN LIGHT OIL Low NOx

N10.12000 GL-EUF	1500 ... 12000 kW		p. 158
------------------	-------------------	--	--------

N LIGHT OIL RANGE

TWO STAGE PROGRESSIVE/MODULATING ELECTRONIC

N10.12000 L-E	3600 ... 12000 kW		p. 162
---------------	-------------------	--	--------

TWO STAGE PROGRESSIVE/MODULATING ELECTRONIC Low NOx

N10.12000 L-EUF	3000 ... 12000 kW		p. 164
N10.14000 L-EUF	3300 ... 14000 kW		p. 164
N10.16000 L-EUF	3800 ... 16000 kW		p. 164

HO-TRON

HEAVY OIL RANGE

ONE STAGE

HO-TRON 0.135	68 ... 136 kW		p. 168
HO-TRON 0.225	108 ... 227 kW		p. 168
HO-TRON 1.350	170 ... 340 kW		p. 170

TWO STAGES

HO-TRON 1.350 Z	205 ... 410 kW		p. 170
HO-TRON 2.580 Z	205 ... 570 kW		p. 170
HO-TRON 2.930 Z	464 ... 930 kW		p. 172
HO-TRON 2.1400 Z	682 ... 1395 kW		p. 172
HO-TRON 3.1700 Z	682 ... 1700 kW		p. 174
HO-TRON 3.2100 Z	682 ... 2093 kW		p. 174
HO-TRON 4.3000 Z	1000 ... 3000 kW		p. 176
HO-TRON 4.3900 Z3	1300 ... 3900 kW		p. 176

TWO STAGE PROGRESSIVE/MODULATING MECHANICAL

HO-TRON 4.3000 R	1000 ... 3000 kW		p. 178
HO-TRON 4.3900 R	1300 ... 3900 kW		p. 178
HO-TRON 5.5000 R	1578 ... 5000 kW		p. 180
HO-TRON 5.5800 R	1795 ... 5800 kW		p. 180
HO-TRON 6.7200 R	2417 ... 7250 kW		p. 182
HO-TRON 6.8500 R	2750 ... 8500 kW		p. 182
HO-TRON 6.10500 R	3300 ... 10500 kW		p. 182
HO-TRON 6.13000 R	4367 ... 12500 kW		p. 182
HO-TRON 7.15000 R	5000 ... 15000 kW		p. 184
HO-TRON 7.17000 R	5700 ... 17000 kW		p. 184

GHO-TRON

DUAL FUEL RANGE (GAS/HEAVY OIL)

TWO STAGES

GHO-TRON 3.2100 Z	414 ... 2150 kW		p. 188
-------------------	-----------------	--	--------

TWO STAGE PROGRESSIVE/MODULATING MECHANICAL

GHO-TRON 4.3000 R	630 ... 3000 kW		p. 190
GHO-TRON 4.3900 R	875 ... 3900 kW		p. 190
GHO-TRON 5.5000 R	1200 ... 5000 kW		p. 192
GHO-TRON 5.5800 R	1500 ... 5800 kW		p. 192
GHO-TRON 6.7200 R	1500 ... 7500 kW		p. 194
GHO-TRON 6.8500 R	2000 ... 8500 kW		p. 194
GHO-TRON 6.10500 R	2500 ... 10500 kW		p. 194
GHO-TRON 6.13000 R	2700 ... 13000 kW		p. 194
GHO-TRON 7.15000 R	3690 ... 15000 kW		p. 196
GHO-TRON 7.17000 R	4000 ... 17000 kW		p. 196

RANGE OVERVIEW

D-TRON DUOBLOCK RANGE (GAS, LIGHT OIL, HEAVY OIL AND DUAL FUEL)

TWO STAGES and TWO STAGE PROGRESSIVE/MODULATING MECHANICAL or ELECTRONIC p. 198

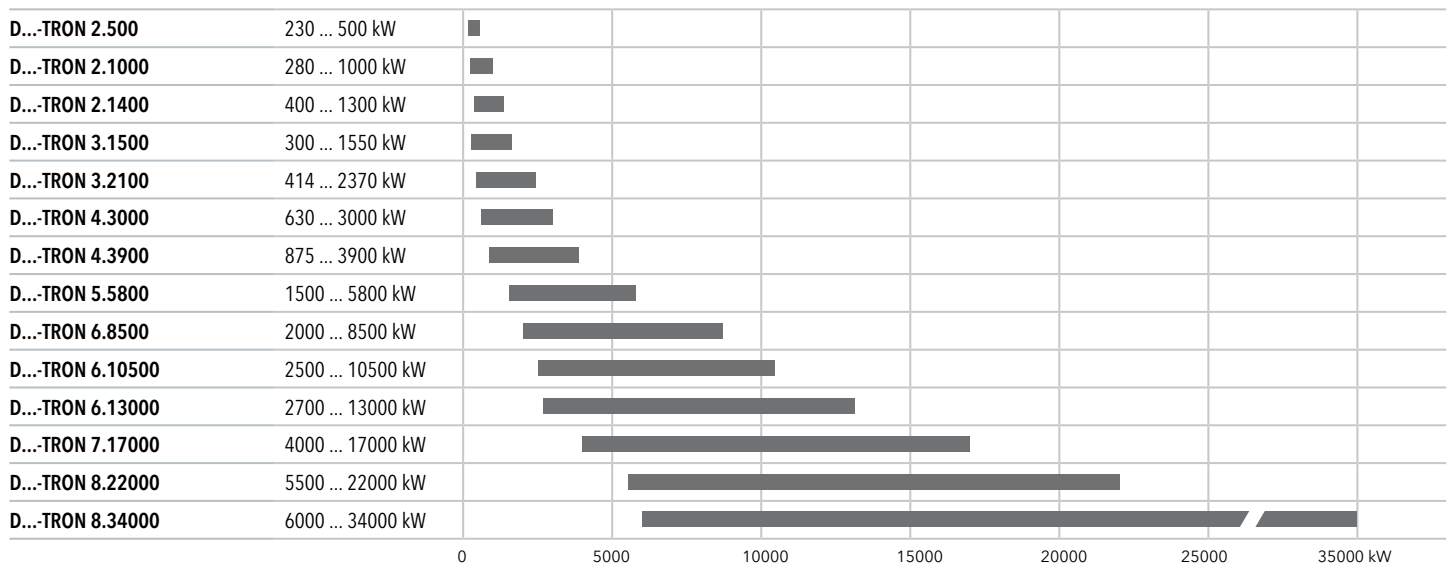

EK-DUO DUOBLOCK RANGE (GAS, LIGHT OIL AND DUAL FUEL)

TWO STAGE PROGRESSIVE/MODULATING ELECTRONIC p. 198

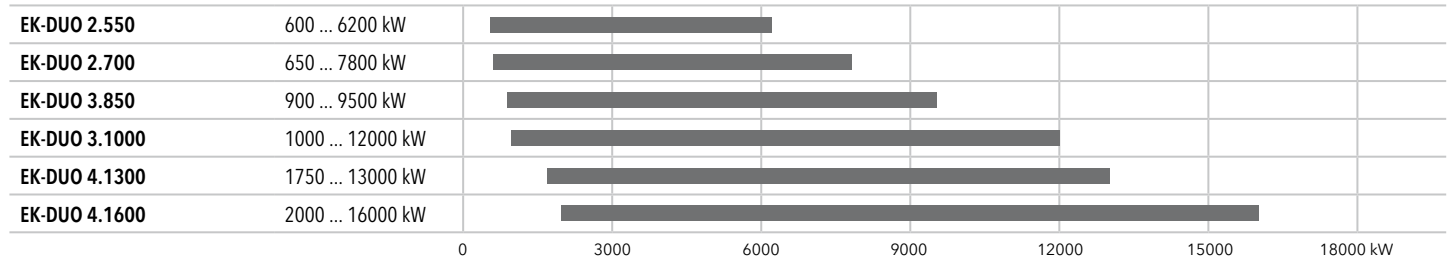

RPD DUOBLOCK RANGE (GAS, LIGHT OIL, HEAVY OIL AND DUAL FUEL)

TWO STAGE PROGRESSIVE/MODULATING MECHANICAL or ELECTRONIC p. 198

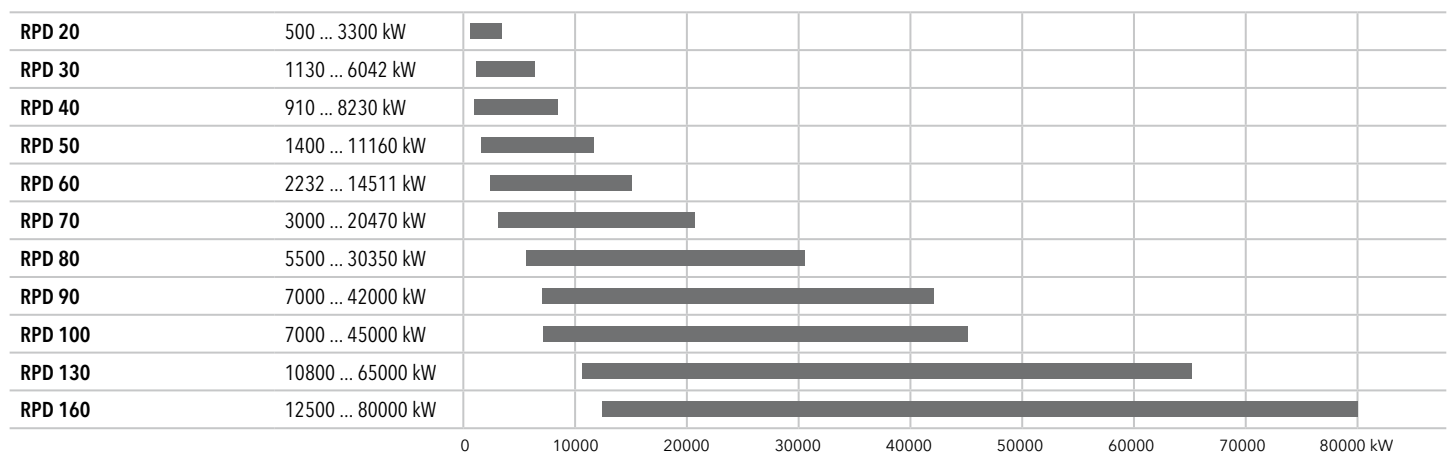

GAS TRAINS

Electronic versions for EK EVO and NEXTRON	p. 206
Electronic versions for N10/N11	p. 208
Mechanical versions for GHO-TRON	p. 210

CONTROL UNITS

BT300	p. 211
ETAMATIC	p. 212

O₂/CO TRIM

O ₂ TRIM for BT300, Etamatic and Etamatic OEM	p. 213
O ₂ TRIM with CO measure for BT300, Etamatic and Etamatic OEM	p. 213

OPTIONS

Frequency converter	p. 214
Acoustic shrouds	p. 215
Options for gas burners	p. 216
Options for light oil burners	p. 222

Monoblock burners from 250 to 13500 kW

Gas, light oil and dual fuel



Robust and professional structure

The design of the EKEVO® is the result of a successful synergy between ELCO key features and essential design.

EKEVO® introduces a brand new aluminium casting body and confirms the choice of ELCO about light colors and harmony of each shape.

Professionals will appreciate the flexibility of a 180° orientable air inlet, the compact switch box and the easy to clean glossy paint.

Electronics: easy and comprehensive

All EKEVO® models are fully electronically controlled and they are equipped with the exclusive ELCO man-machine interface allowing simple and effective programming operations.



A total advantage in terms of flexibility

The EKEVO® are characterized by their total flexibility of installation; they have been designed to be installed in different ways: up-firing, down-firing, upside-down or side-to-side (twin chamber boilers). Options and configurations have been foreseen in order to fulfill any application need.

Smart solutions for easy maintenance

The maintenance of the EKEVO® burners can comfortably be carried out thanks to a wide opening above the housing, allowing easy access to the combustion components up to the fan, and thanks to the choice of the material: aluminium, lightweight to handle and resistant at the same time.

Maintenance operations are possible keeping the original combustion components setup.



MAIN TECHNICAL FEATURES

- Two stage progressive/modulating forced draught burner
- Fuels:
 - natural gas, Hi = 6,99 ... 11,39 kWh/Nm³
 - LPG, Hi = 25,89 kWh/Nm³
 - light oil, viscosity 6 mm²/s at 20°C, Hi = 11,86 kWh/kg
- Combustion technology:
 - Low NOx class 2 (≤ 120 mg/kWh) and class 3 (≤ 80 mg/kWh) in gas operation according to EN676
 - Low NOx class 2 (≤ 185 mg/kWh) and class 3 (≤ 120 mg/kWh) in light oil operation according to EN267
- Integrated switch cabinet (ISC System) with modular concept complete for an easy installation with:
 - BT300 control box
 - fan motor direct start-up
 - enumerated connection terminals
 - three-phase electrical power supply
 - available as options: power regulator, speed controller, O₂/CO regulator and BUS interface
- Innovative design allowing easy access to burner components for fast start-up and reduced maintenance time and space
- Three flame tube lengths available
- Orientable air intake box
- Secured burner head adjustments during maintenance (RTC System)
- Closing of the air damper on burner shut-down
- Multiple gas train matching according to the inlet gas pressure
- Gas train factory assembled and tested for tightness and electrical security
- Products are in compliance with EN676 and EN267 European standards and with the following directives:
 - 2014/35/UE Low Voltage Directive
 - 2014/30/UE EMC Directive
 - 2016/426/UE Gas Appliances Regulation
 - 2006/42/EC Machinery Directive
 - 2011/65/EU RoHS2 Directive

RANGE OVERVIEW

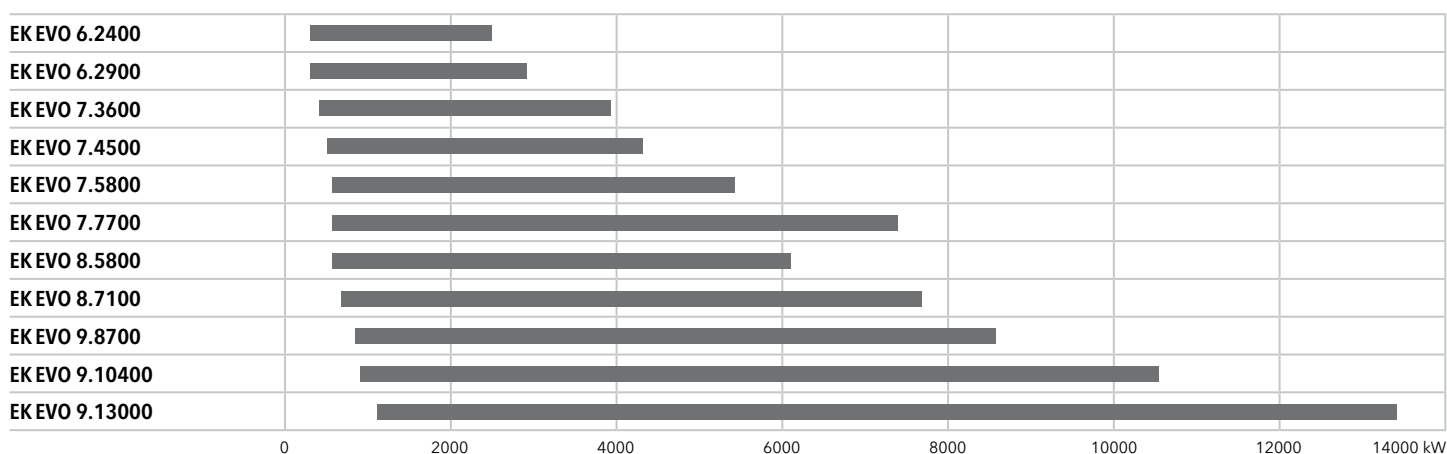

EKEVO 6 G-E, EKEVO 7 G-E

390 ... 5400 kW

2 stage progressive/modulating electronic

- **Fuels:** natural gas, Hi = 6,99 ... 11,39 kWh/Nm³;
LPG, Hi = 25,89 kWh/Nm³
- **Emission class:** Low NOx class 2 (≤120 mg/kWh) according to EN676
- **Protection level:** IP 41



TECHNICAL DATA

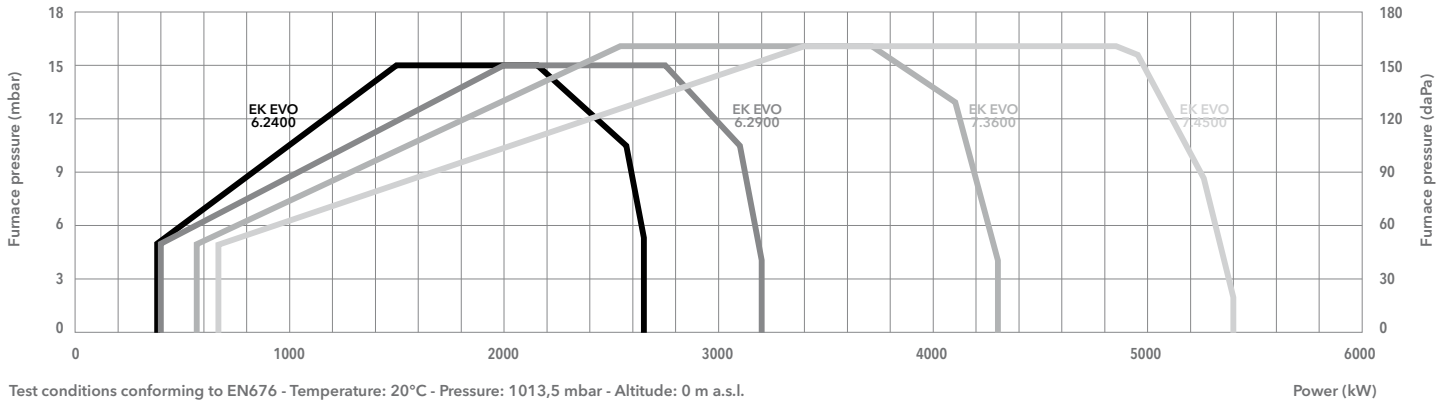

Test conditions conforming to EN676 - Temperature: 20°C - Pressure: 1013,5 mbar - Altitude: 0 m a.s.l.

	EKEVO 6.2400 G-E	EKEVO 6.2900 G-E	EKEVO 7.3600 G-E	EKEVO 7.4500 G-E
Operating range	390 – 2650 kW	400 – 3200 kW	580 – 4300 kW	680 – 5400 kW
Gas pressure	50 – 500 mbar (max 360 mbar for d452 and d453 gas train)	55 – 500 mbar (max 360 mbar for d452 and d453 gas train)	60 – 500 mbar (max 360 mbar for d452 and d453 gas train)	65 – 500 mbar (max 360 mbar for d452 and d453 gas train)
Gas connection	DN65	DN65	DN65	DN65
Control box / flame detector	BT300 / Ionisation	BT300 / Ionisation	BT300 / Ionisation	BT300 / Ionisation
Auxiliary voltage	1NPE AC 230 V - 50 Hz TN-S	1NPE AC 230 V - 50 Hz TN-S	1NPE AC 230 V - 50 Hz TN-S	1NPE AC 230 V - 50 Hz TN-S
Power supply	3PE AC 400 V - 50 Hz	3PE AC 400 V - 50 Hz	3PE AC 400 V - 50 Hz	3PE AC 400 V - 50 Hz
Fan motor	50 Hz - 3 kW	50 Hz - 4 kW	50 Hz - 5,5 kW	50 Hz - 7,5 kW
Acoustic level	<75 dB(A)	<77 dB(A)	<81 dB(A)	<82,5 dB(A)
CE certificate	0085CL0215	0085CL0215	0085CL0215	0085CL0215
Burner codes (body + head)	KN	3752745	3752746	3752748
	KM	3752749	3752750	3752752
	KL	3752753	3752754	3752756

GAS TRAINS

DUNGS

Model	Code
GT-d452-1"1/2 (*)	3750510
GT-d453-2" (*)	3750511
GT-d454-65	3750512
GT-d455-80	3750513
GT-d456-100	3750514

SIEMENS

Model	Code
GT-s451-1"1/2	3750525
GT-s452-2"	3750526
GT-s453-65	3750527
GT-s454-80	3750528
GT-s455-100	3750529
GT-s456-125	3750530

FILTERS

Model	Code
FG-Rp1"1/2	3757199
FG-Rp2"	3757200
FG-DN65	3757198
FG-DN80	3757201
FG-DN100	3757195
FG-DN125	3757209

*: integrated filter

Pressure drops graphs: see following pages
Dimensions of gas trains and gas filters: see pag. 206

DIMENSIONS (mm)

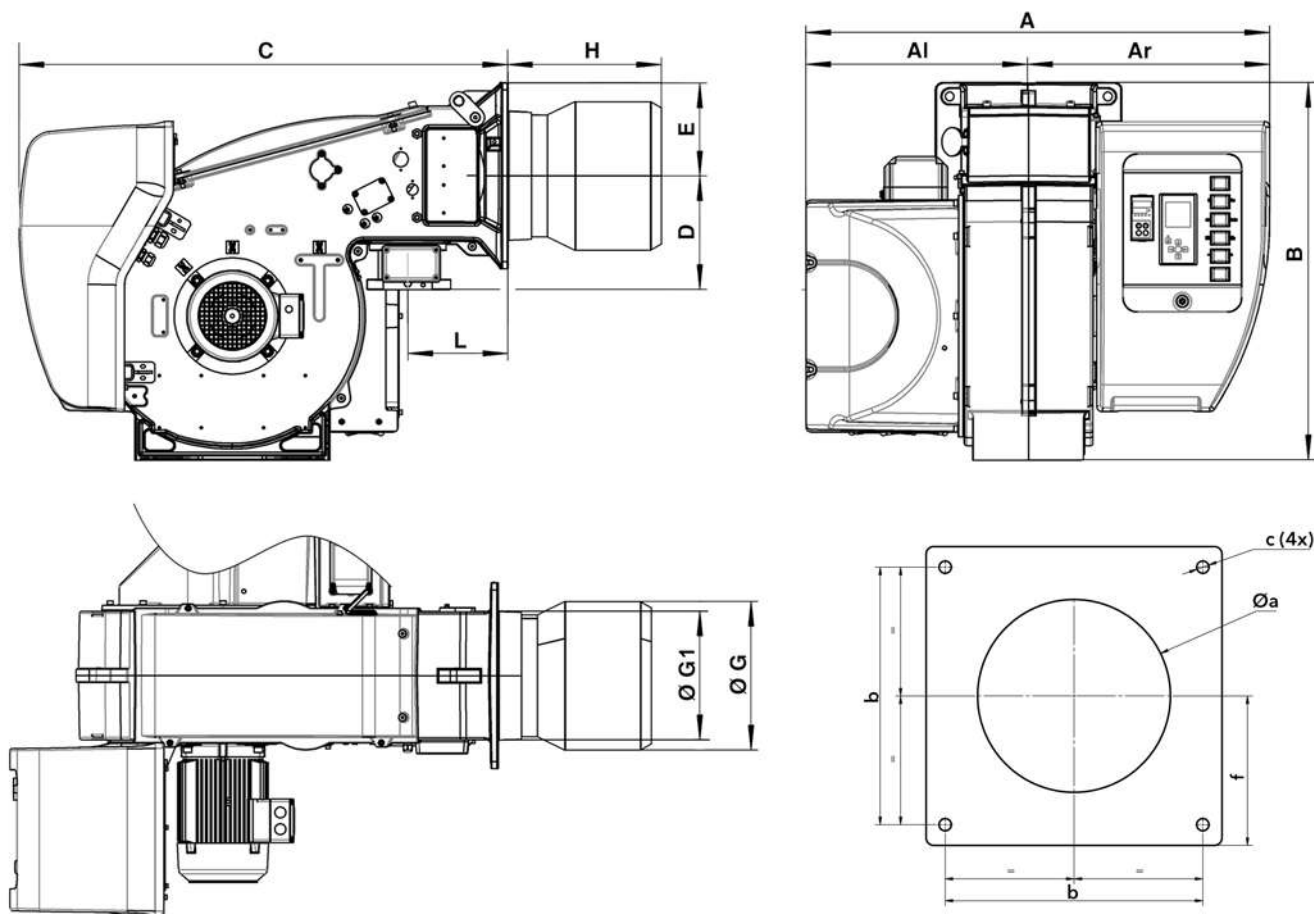

Model	A	Al	Ar	B	C	D	E	ØG	ØG1	H			L	Øa	b	c	f
										KN	KM	KL					
EKEVO 6	1035	479	556	812	1054	245	200	320	277	330	450	570	223	330-340	340	M16	200
EKEVO 7	1107	510	597	941	1130	276	235	370	338	375	505	635	233	380-400	400	M16	235

PACKAGING

The burner is delivered on a pallet in 2 packages containing:

- burner body with mounted combustion head, boiler fixing accessories and technical documentation;
- gas train and filter.

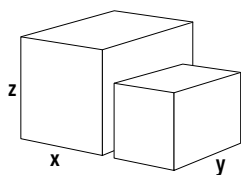

Models	Dimensions (mm)			Gross weight (kg)	
	X	Y	Z		
EK EVO 6.2400 G-E	KN	2070	1420	990	168
	KM	2070	1420	990	170
	KL	2070	1420	990	172
EK EVO 6.2900 G-E	KN	2070	1420	990	174
	KM	2070	1420	990	176
	KL	2070	1420	990	178
EK EVO 7.3600 G-E	KN	2070	1420	1130	212
	KM	2070	1420	1130	214
	KL	2070	1420	1130	216
EK EVO 7.4500 G-E	KN	2070	1420	1130	218
	KM	2070	1420	1130	220
	KL	2070	1420	1130	222

PRESSURE LOSSES (BURNER HEAD + GAS TRAIN)

EK EVO 6.2400 G-E

DUNGS

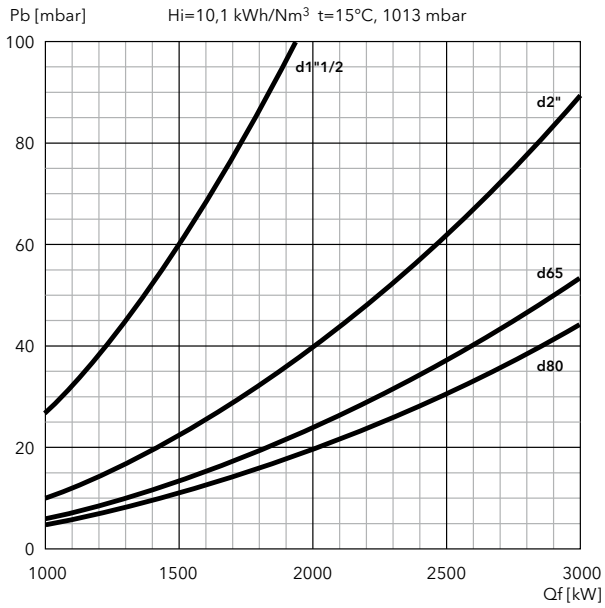

SIEMENS

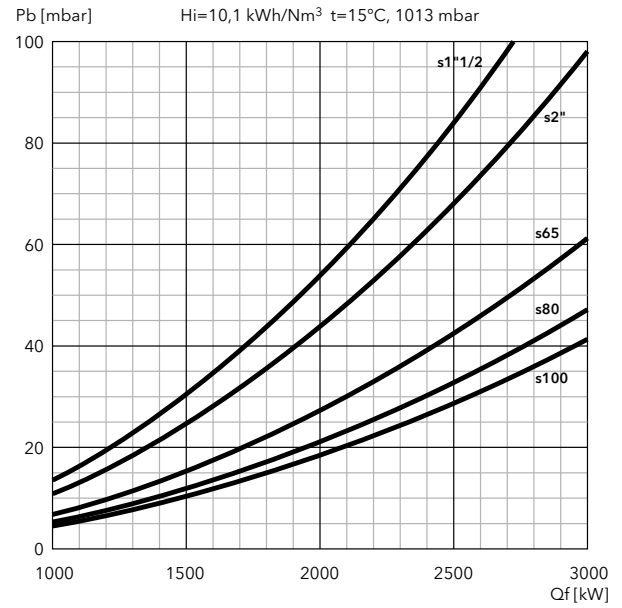

EK EVO 6.2900 G-E

DUNGS

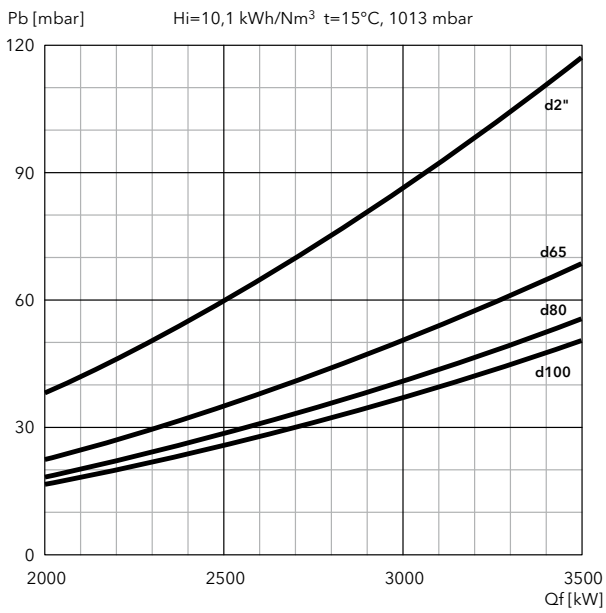

SIEMENS

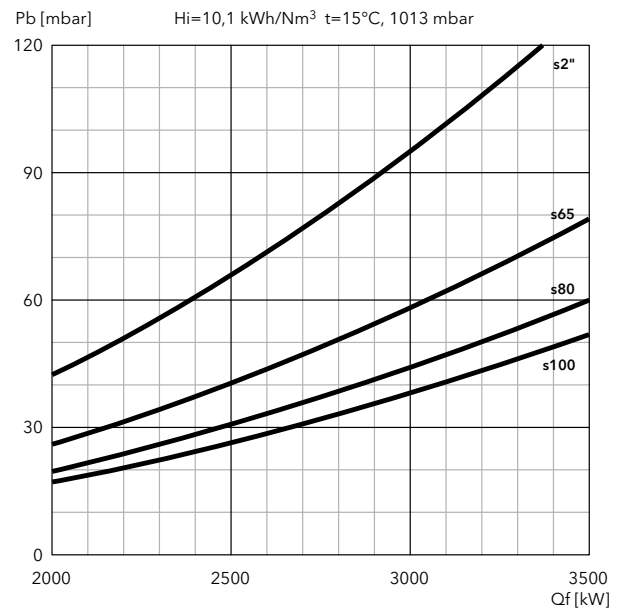

FILTERS

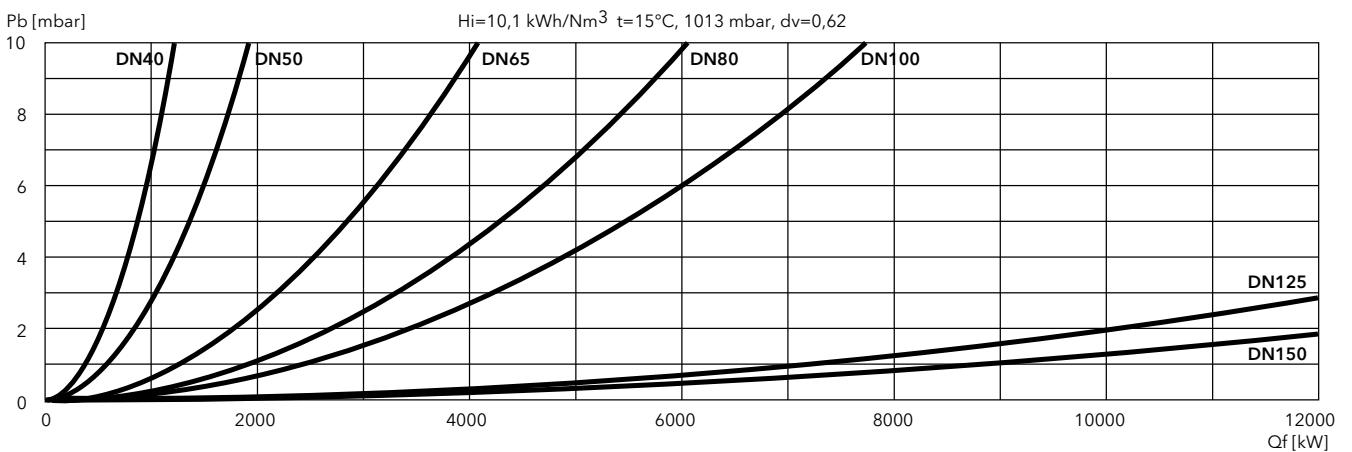

PRESSURE LOSSES (BURNER HEAD + GAS TRAIN)

EK EVO 7.3600 G-E

DUNGS

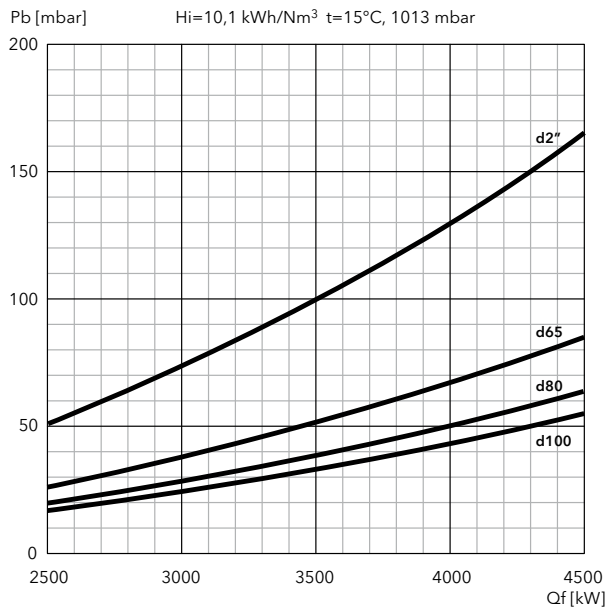

SIEMENS

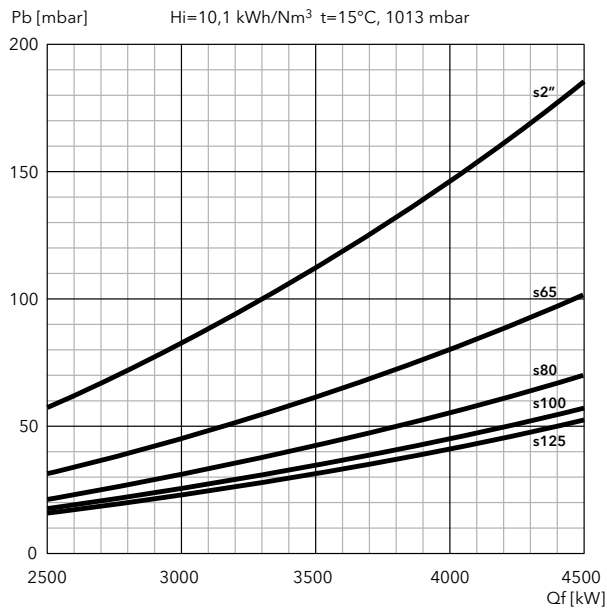

EK EVO 7.4500 G-E

DUNGS

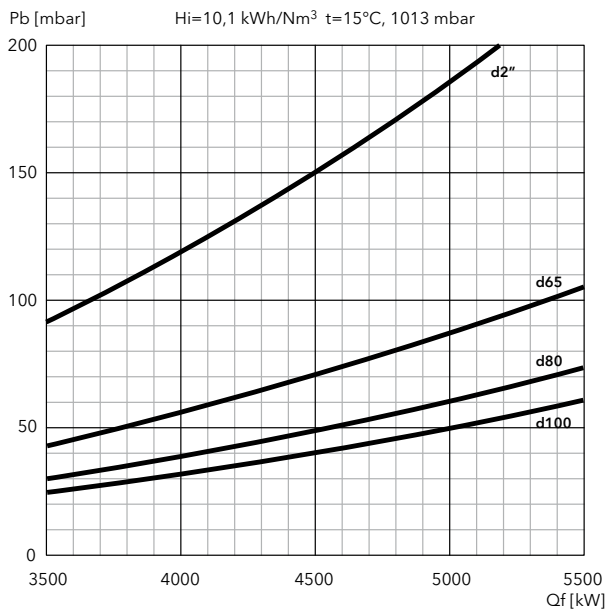

SIEMENS

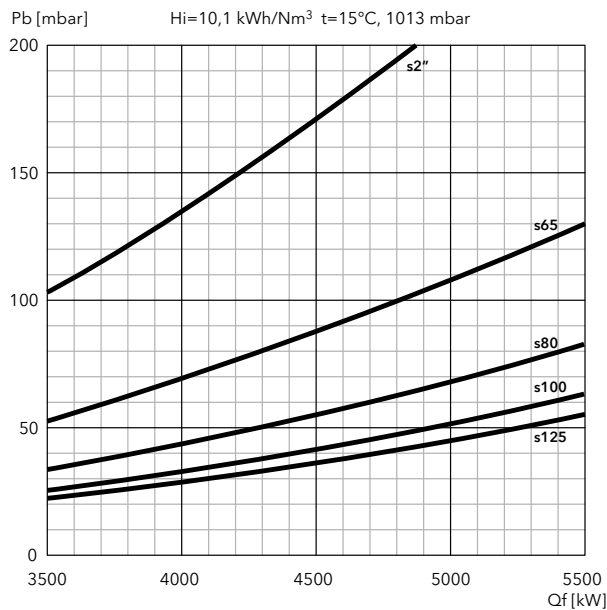

FILTERS

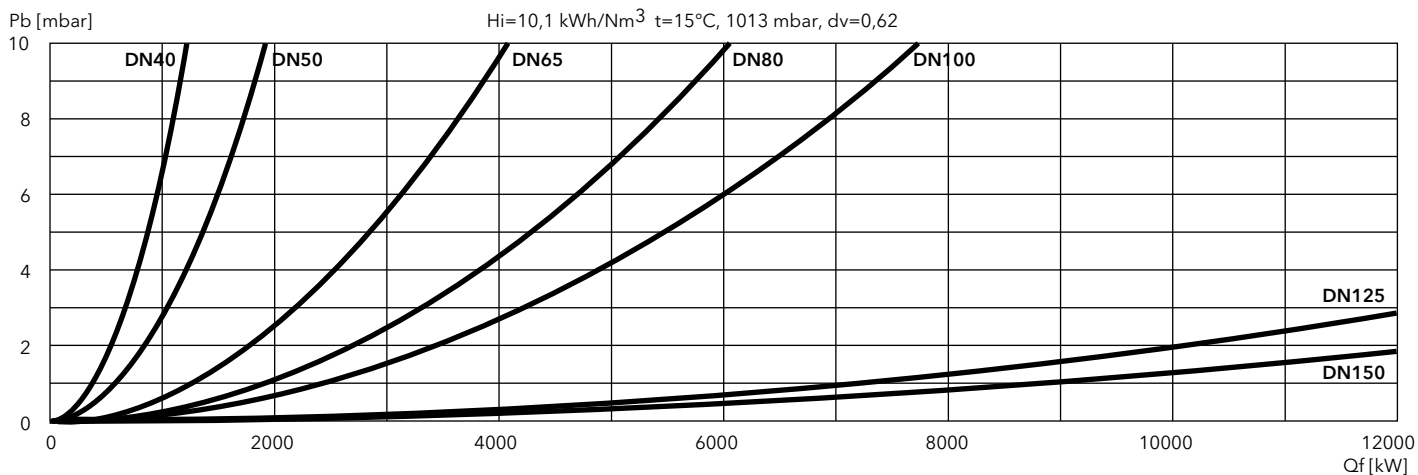

EKEVO 8 G-E, EKEVO 9 G-E

610 ... 11230 kW

2 stage progressive/modulating electronic

- **Fuels:** natural gas, Hi = 6,99 ... 11,39 kWh/Nm³;
LPG, Hi = 25,89 kWh/Nm³
- **Emission class:** Low NOx class 2 (≤120 mg/kWh) according to EN676
- **Modulating ratio:** 1:10
- **Protection level:** IP 41

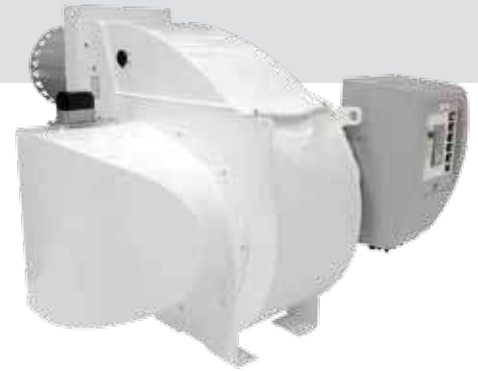

TECHNICAL DATA

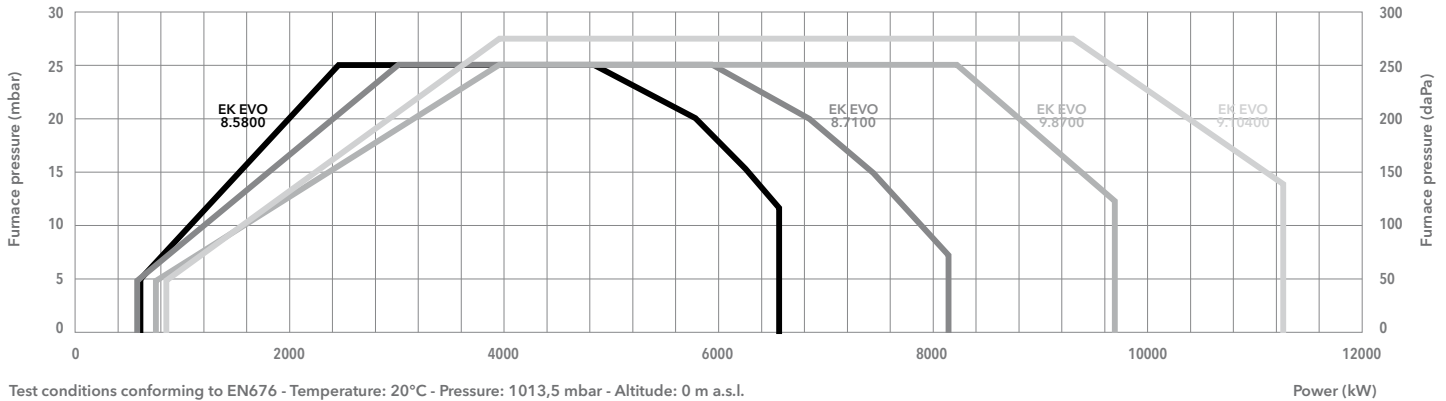

	EKEVO 8.5800 G-E	EKEVO 8.7100 G-E	EKEVO 9.8700 G-E	EKEVO 9.10400 G-E
Operating range	620 - 6570 kW	610 - 8150 kW	780 - 9700 kW	850 - 11230 kW
Gas pressure	60 - 500 mbar (60 - 360 mbar for d457)			
Gas connection	DN100			
Control box / flame detector	BT300 / Ionisation			
Auxiliary voltage	1NPE AC 230 V - 50 Hz TN-S			
Power supply	3PE AC 400 V - 50 Hz			
Fan motor	50 Hz - 11 kW	50 Hz - 15 kW	50 Hz - 18,5 kW	50 Hz - 22 kW
Acoustic level	<80,3 dB(A)	<81 dB(A)	<84,8 dB(A)	<86,3 dB(A)
CE certificate	0085CL0215			
Burner codes (body + head)	KN	3753965	3753966	3753967
	KM	3753974	3753975	3753976
	KL	3753982	3753983	3753984

GAS TRAINS

DUNGS

Model	Code
GT-d457-2" (*)	3750515
GT-d458-65	3750516
GT-d459-80	3750517
GT-d460-100	3750518

*: integrated filter

SIEMENS

Model	Code
GT-s457-2"	3750537
GT-s458-65	3750538
GT-s459-80	3750539
GT-s460-100	3750540
GT-s461-125	3750541

FILTERS

Model	Code
FG-Rp2"	3757200
FG-DN65	3757198
FG-DN80	3757201
FG-DN100	3757195
FG-DN125	3757209

Pressure drops graphs: see following pages
Dimensions of gas trains and gas filters: see pag. 207



DIMENSIONS (mm)

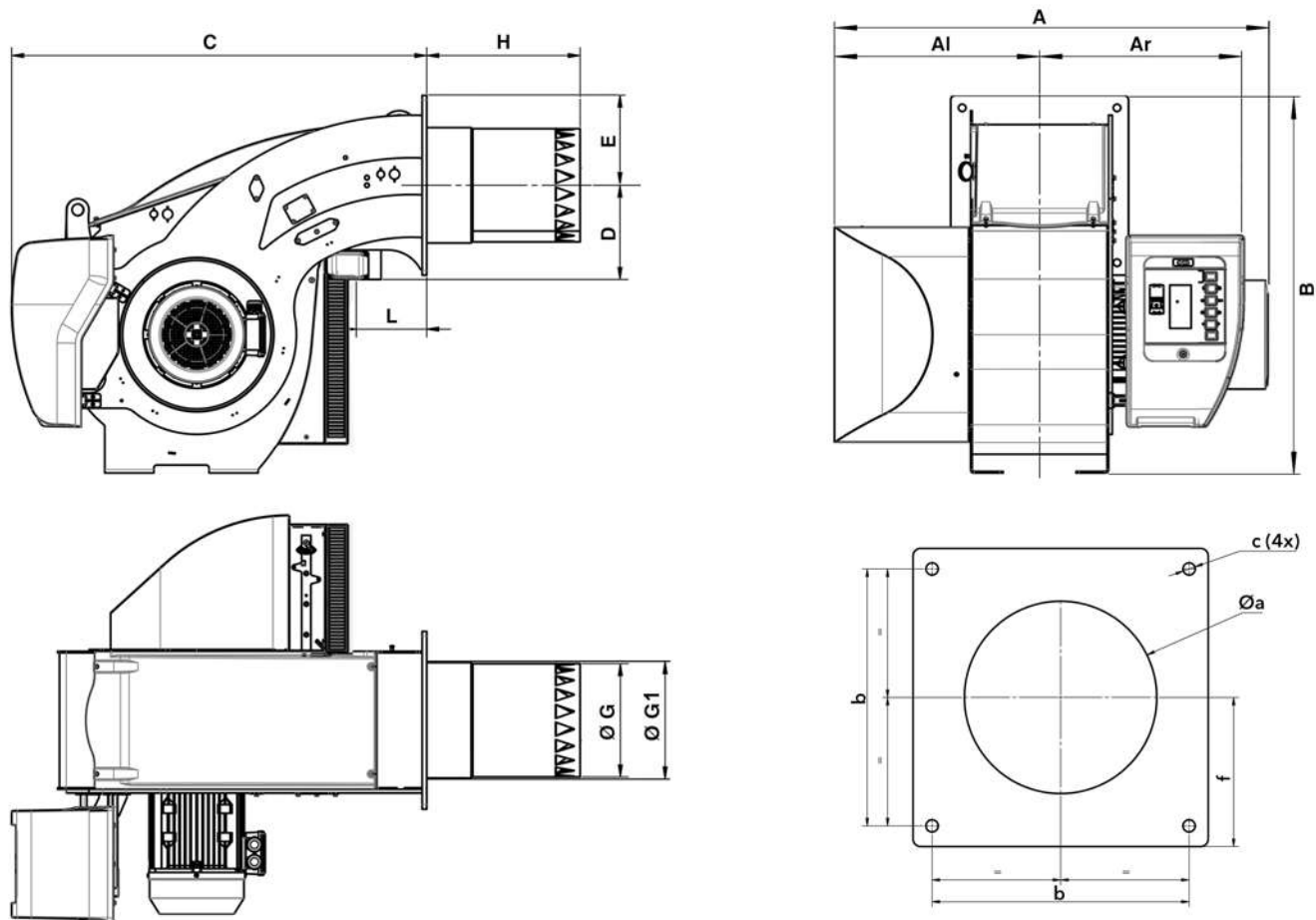

Model	A	Al	Ar	B	C	D	E	ØG	ØG1	H			L	Øa	b	c	f
										KN	KM	KL					
EK EVO 8...	1323	670	653	1231	1353	307	288	369	376	500	640	780	230	390-410	505	M20	293
EK EVO 9.8700	1335	670	653	1291	1350	332	293	432	439	550	700	850	230	460-480	505	M20	293
EK EVO 9.10400	1401	670	653	1291	1350	332	293	432	439	550	700	850	230	460-480	505	M20	293

PACKAGING

The burner is delivered on a pallet in 2 packages containing:

- burner body with mounted combustion head, boiler fixing accessories and technical documentation;
- gas train and filter.

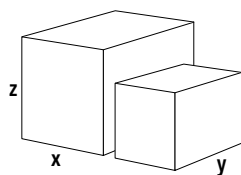

Models	Dimensions (mm)			Gross weight (kg)	
	X	Y	Z		
EK EVO 8.5800 G-E	KN	2300	1500	1396	481
	KM	2300	1500	1396	487
	KL	2300	1500	1396	498
EK EVO 8.7100 G-E	KN	2300	1500	1396	497
	KM	2300	1500	1396	503
EK EVO 9.8700 G-E	KN	2300	1500	1461	524
	KM	2300	1500	1461	532
EK EVO 9.10400 G-E	KN	2300	1500	1461	539
	KL	2300	1500	1461	546
EK EVO 9.10400 G-E	KN	2300	1500	1461	546
	KM	2300	1500	1461	553
	KL	2300	1500	1461	565

PRESSURE LOSSES (BURNER HEAD + GAS TRAIN)

EK EVO 8.5800 G-E

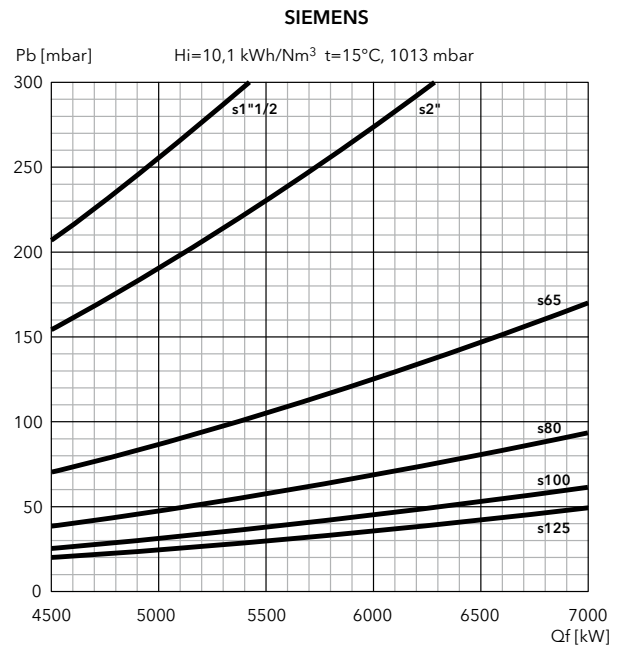
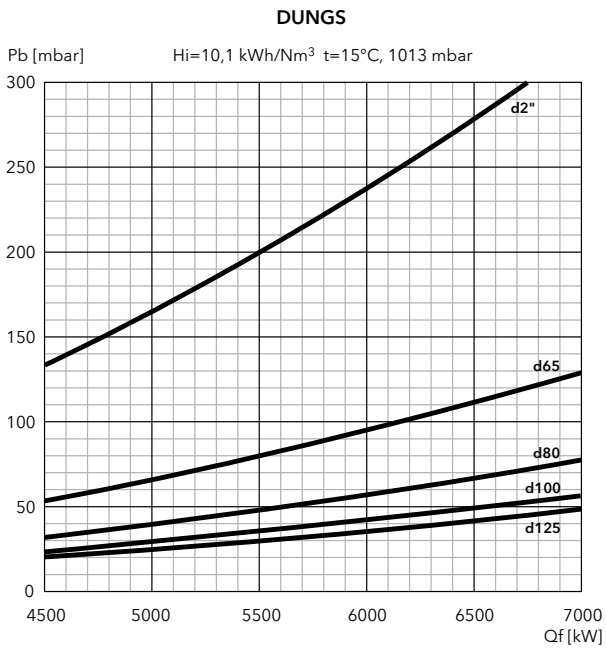

EK EVO 8.7100 G-E

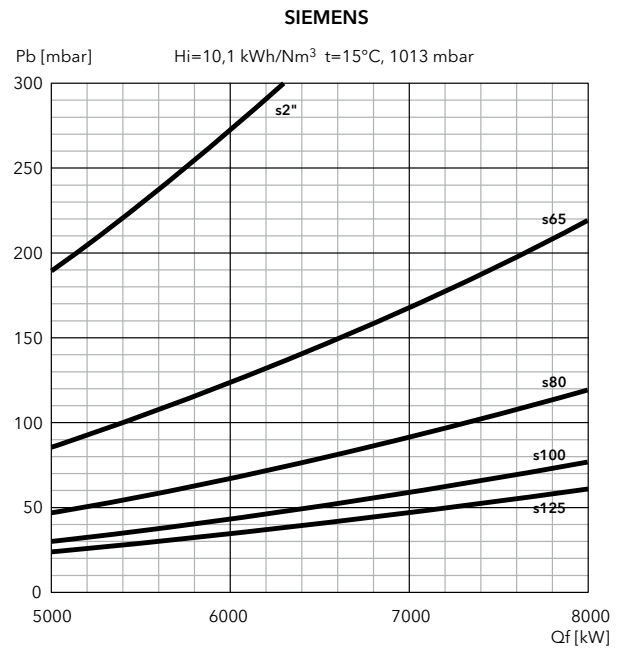
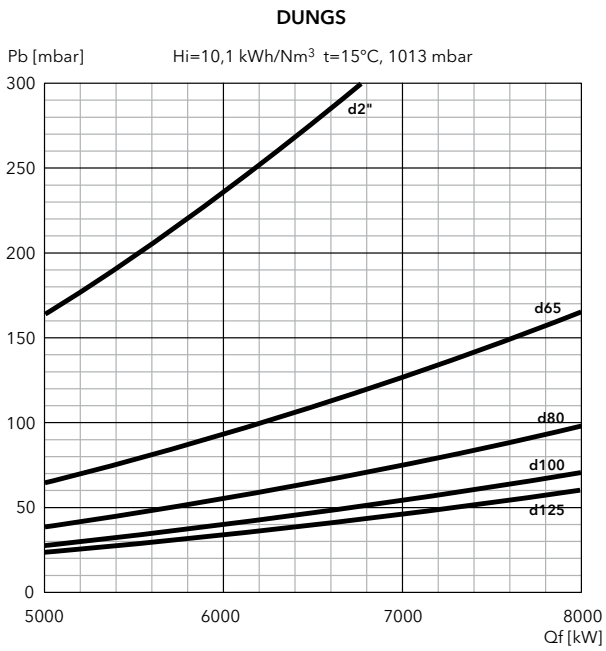

FILTERS

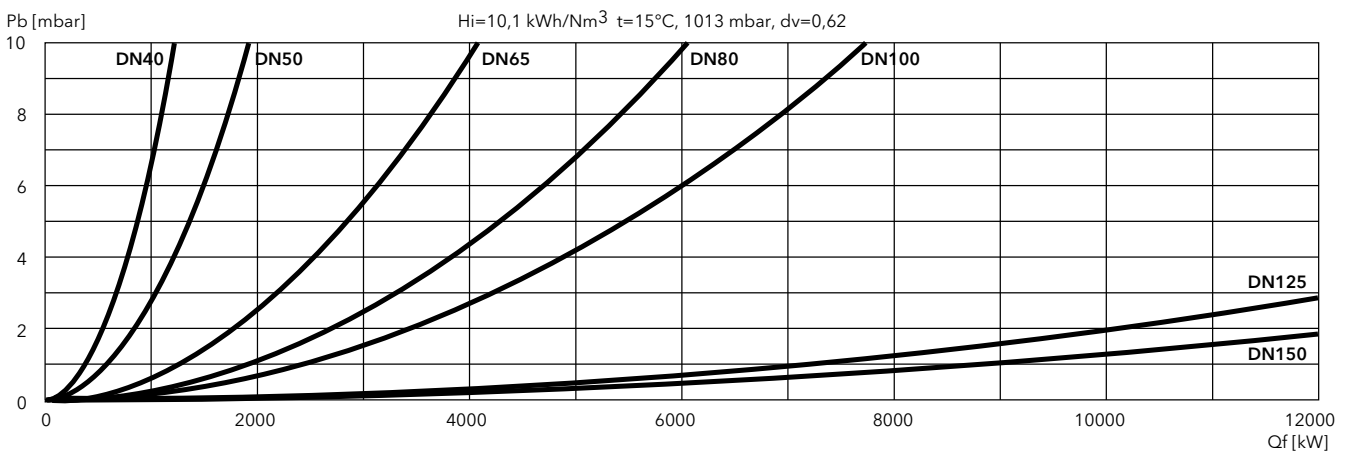

PRESSURE LOSSES (BURNER HEAD + GAS TRAIN)

EK EVO 9.8700 G-E

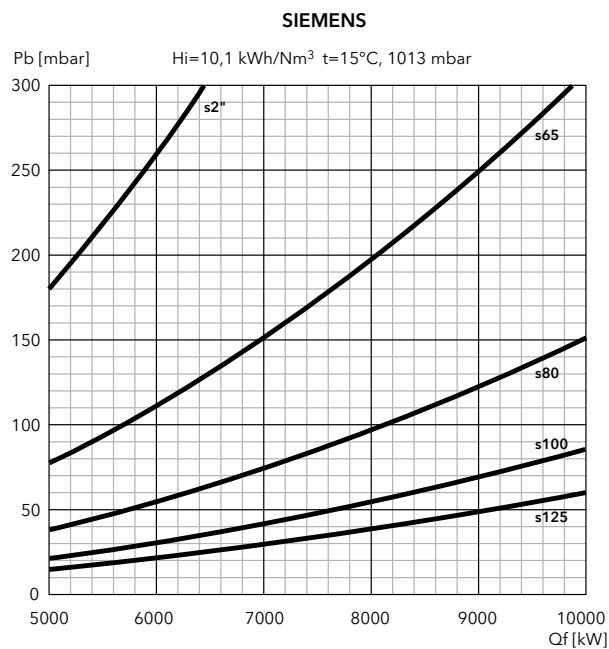
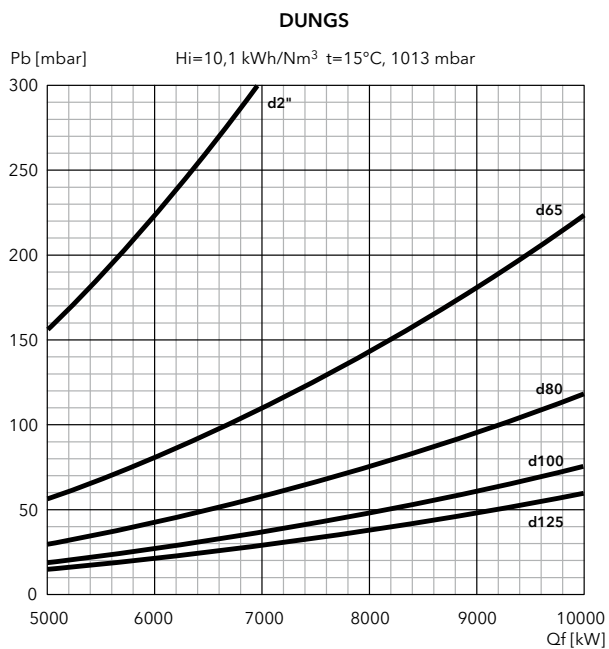

EK EVO 9.10400 G-E

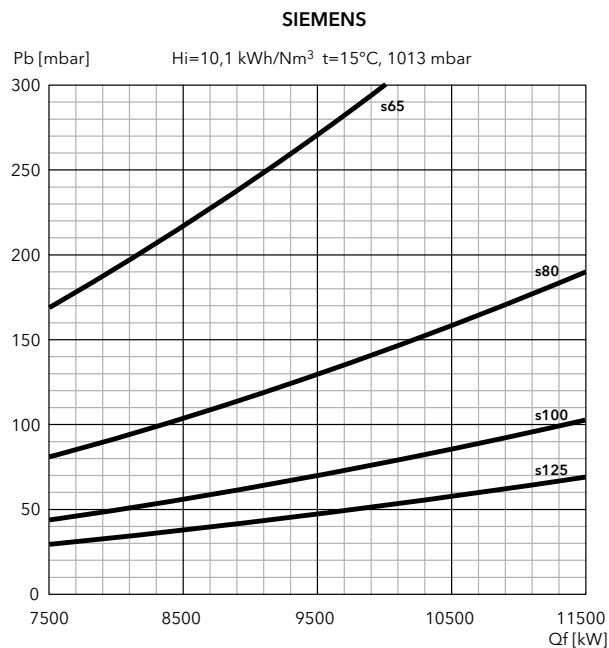
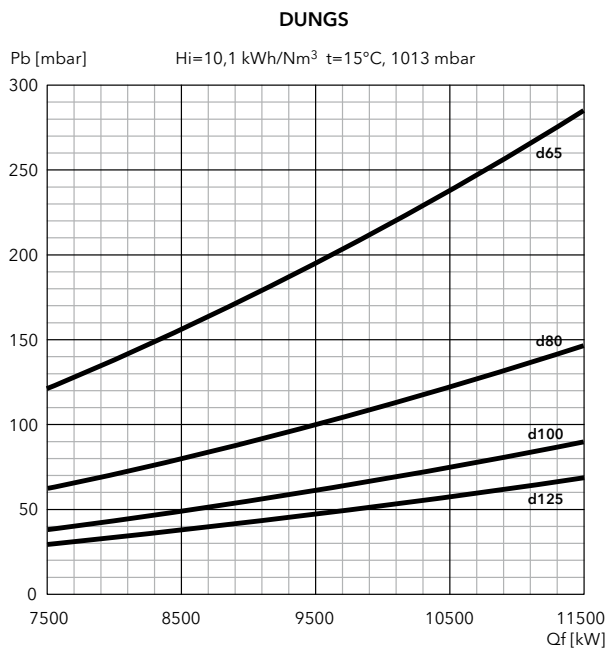

FILTERS

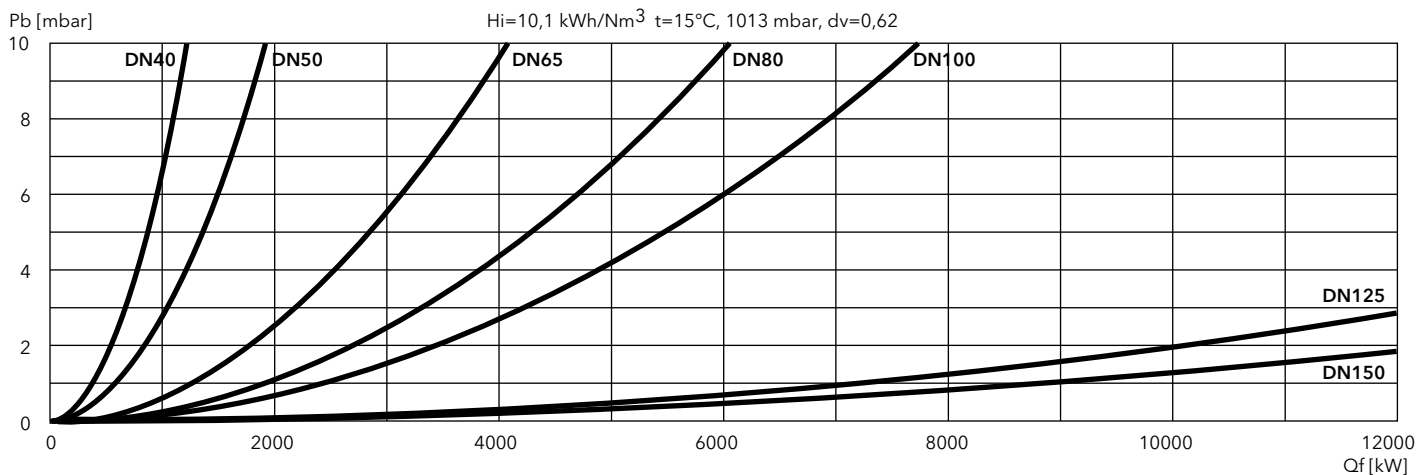

EKEVO 6 G-EF3

340 ... 2900 kW

2 stage progressive/modulating electronic (Low NOx class 3)

- **Fuels:** natural gas, Hi = 6,99 ... 11,39 kWh/Nm³;
LPG, Hi = 25,89 kWh/Nm³
- **Emission class:** Low NOx class 3 (≤80 mg/kWh) according to EN676
Version with FGR System (≤30 mg/kWh) available on request
- **Protection level:** IP 41



TECHNICAL DATA

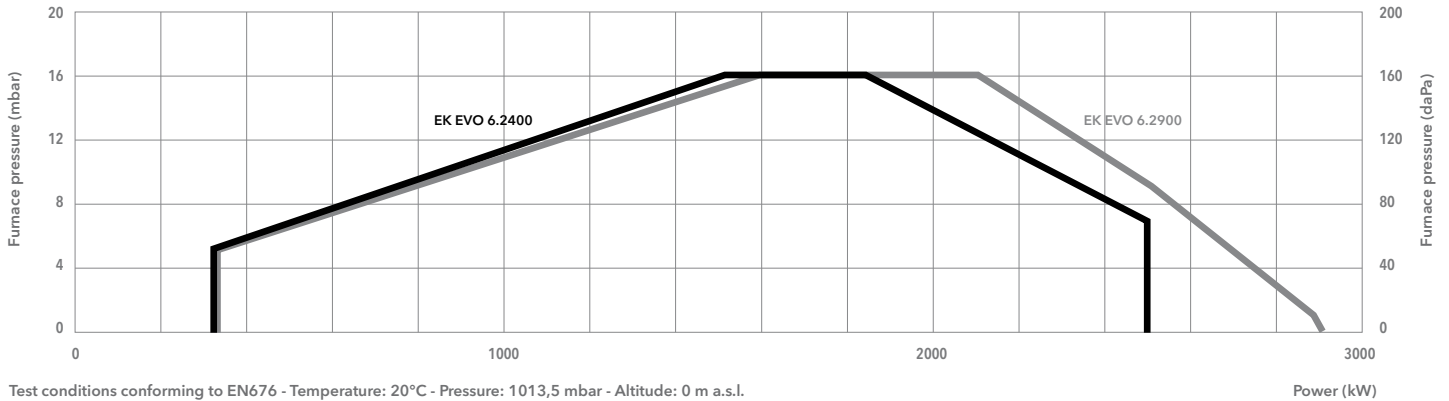

Test conditions conforming to EN676 - Temperature: 20°C - Pressure: 1013,5 mbar - Altitude: 0 m a.s.l.

	EK EVO 6.2400 G-EF3	EK EVO 6.2900 G-EF3
Operating range	340 – 2500 kW	340 – 2900 kW
Gas pressure	50 – 500 mbar (50 - 360 mbar for d452 and d453)	50 – 500 mbar (50 - 360 mbar for d452 and d453)
Gas connection	DN65	DN65
Control box / flame detector	BT300 / QRA2	BT300 / QRA2
Auxiliary voltage	1NPE AC 230 V - 50 Hz TN-S	1NPE AC 230 V - 50 Hz TN-S
Power supply	3PE AC 400 V - 50 Hz	3PE AC 400 V - 50 Hz
Fan motor	50 Hz - 3 kW	50 Hz - 4 kW
Acoustic level	<74 dB(A)	<77 dB(A)
CE certificate	0085CL0215	0085CL0215
Burner codes (body + head)	KN	3754046
	KM	3754050
	KL	3754054
		3754051
		3754055

GAS TRAINS

DUNGS

Model	Code
GT-d452-1"1/2 (*)	3750510
GT-d453-2" (*)	3750511
GT-d454-65	3750512
GT-d455-80	3750513

*: integrated filter

SIEMENS

Model	Code
GT-s451-1"1/2	3750525
GT-s452-2"	3750526
GT-s453-65	3750527
GT-s454-80	3750528
GT-s455-100	3750529

FILTERS

Model	Code
FG-Rp1"1/2	3757199
FG-Rp2"	3757200
FG-DN65	3757198
FG-DN80	3757201
FG-DN100	3757195

 **Pressure drops graphs:** see following pages
Dimensions of gas trains and gas filters: see pag. 206



DIMENSIONS (mm)

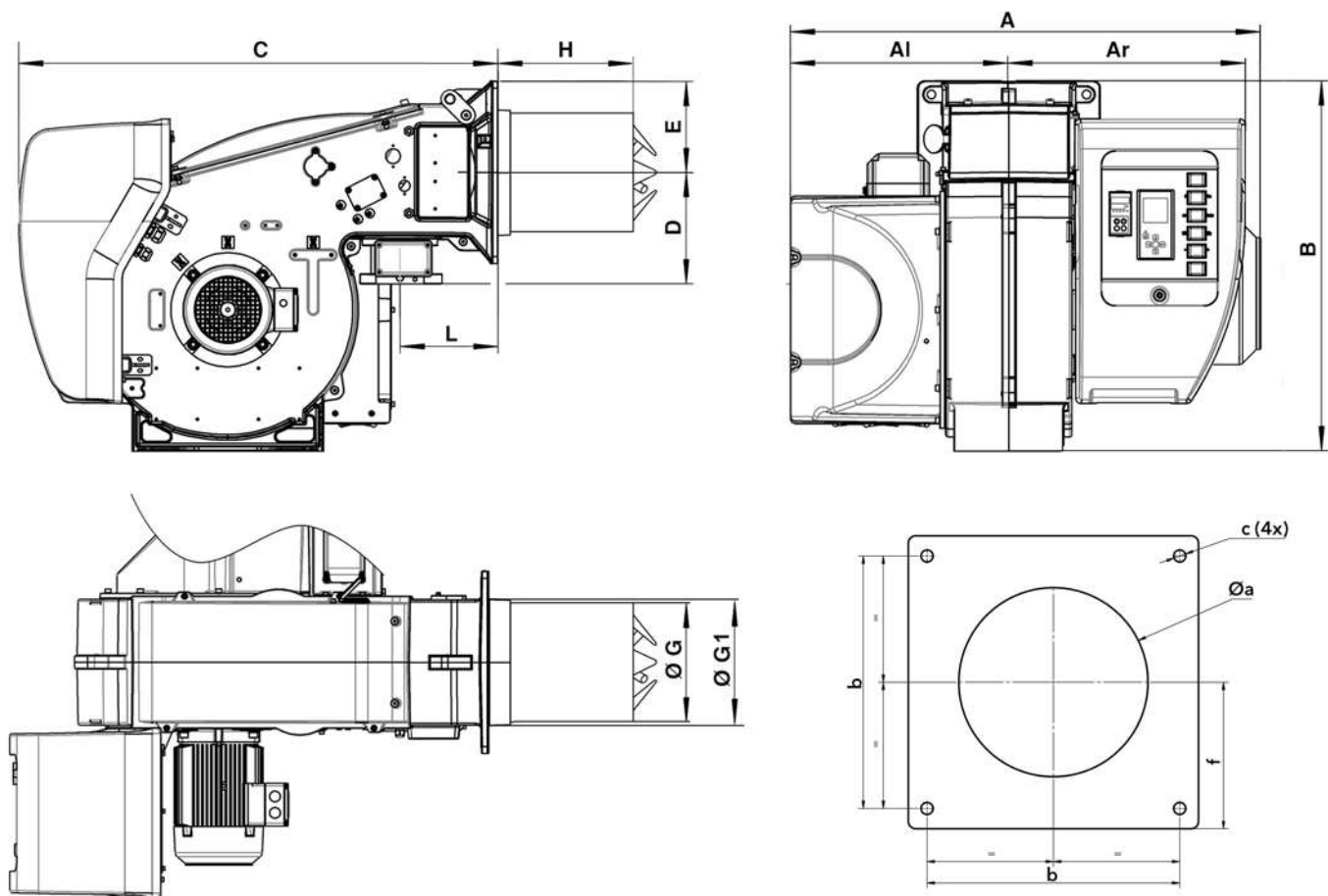

A	Al	Ar	B	C	D	E	ØG	ØG1	H			L	Øa	b	c	f
									KN	KM	KL					
1035	479	556	812	1046	245	200	263	277	400	520	640	215	300-340	340	M16	200

PACKAGING

The burner is delivered on a pallet in 2 packages containing:

- burner body with mounted combustion head, boiler fixing accessories and technical documentation;
- gas train and filter.

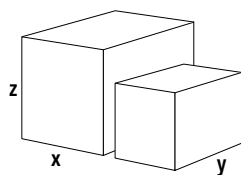

Models	Dimensions (mm)			Gross weight (kg)	
	X	Y	Z		
EK EVO 6.2400 G-EF3	KN	2070	1420	990	168
	KM	2070	1420	990	170
	KL	2070	1420	990	172
EK EVO 6.2900 G-EF3	KN	2070	1420	990	174
	KM	2070	1420	990	176
	KL	2070	1420	990	178

PRESSURE LOSSES (BURNER HEAD + GAS TRAIN)

EK EVO 6.2400 G-EF3

DUNGS

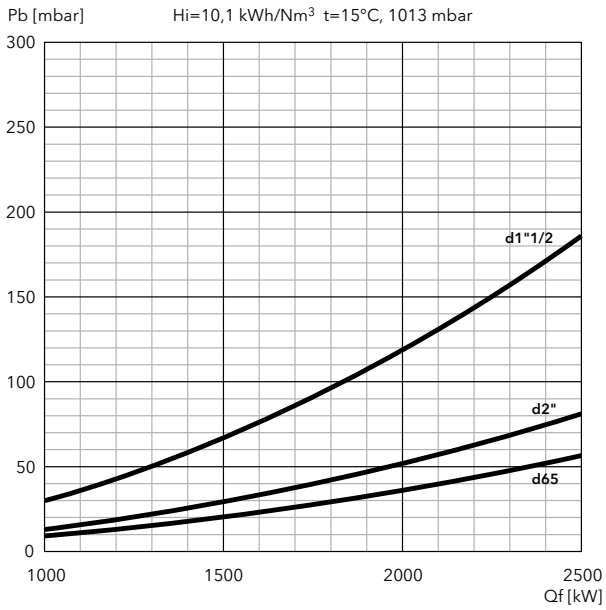

SIEMENS

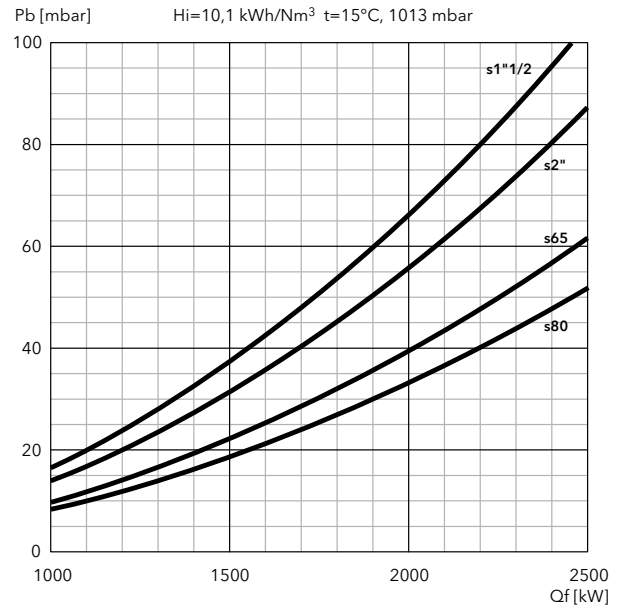

FILTERS

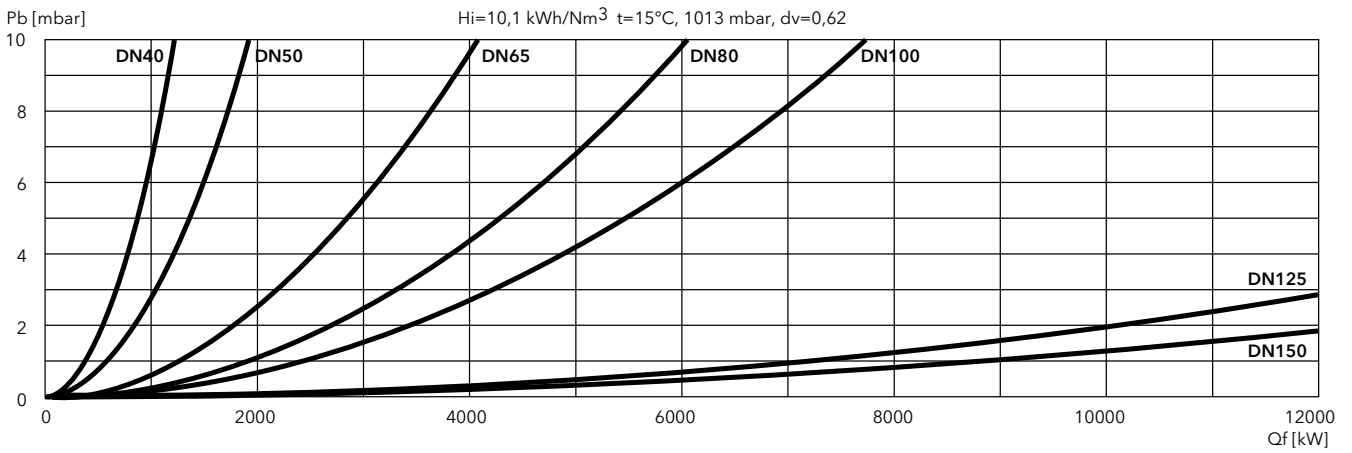

PRESSURE LOSSES (BURNER HEAD + GAS TRAIN)

EK EVO 6.2900 G-EF3

DUNGS

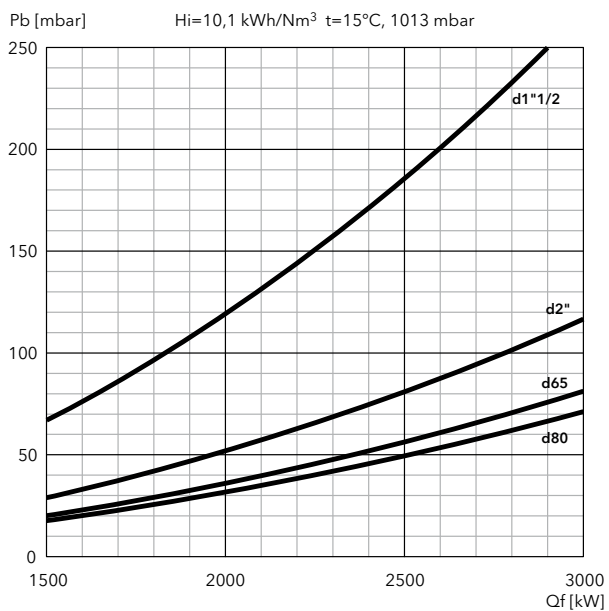

SIEMENS

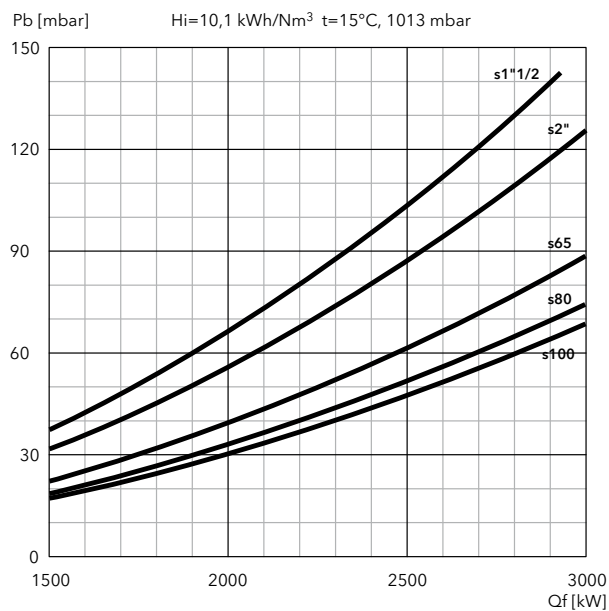

FILTERS

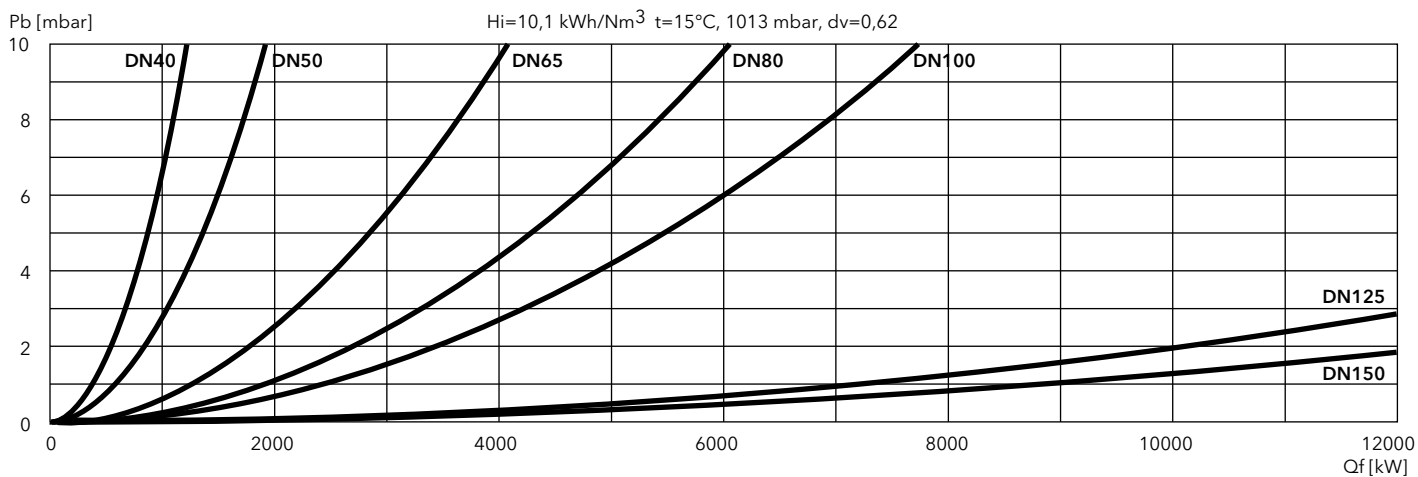

EKEVO 7 G-EF3

470 ... 5500 kW

2 stage progressive/modulating electronic (Low NOx class 3)

- **Fuels:** natural gas, Hi = 6,99 ... 11,39 kWh/Nm³;
LPG, Hi = 25,89 kWh/Nm³
- **Emission class:** Low NOx class 3 (≤80 mg/kWh) according to EN676
Version with FGR System (≤30 mg/kWh) available on request
- **Protection level:** IP 41



TECHNICAL DATA

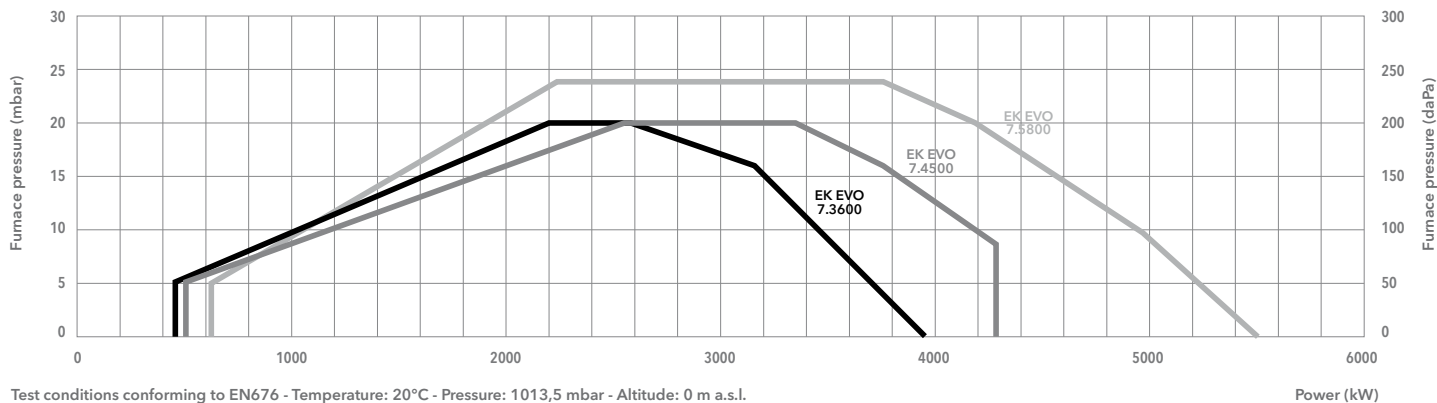

Test conditions conforming to EN676 - Temperature: 20°C - Pressure: 1013,5 mbar - Altitude: 0 m a.s.l.

	EK EVO 7.3600 G-EF3	EK EVO 7.4500 G-EF3	EK EVO 7.5800 G-EF3
Operating range	470 - 3980 kW	510 - 4290 kW	620 - 5500 kW
Gas pressure	50 - 500 mbar (50 - 360 mbar for d452 and d453)		
Gas connection	DN65	DN65	DN65
Control box / flame detector	BT300 / QRA2	BT300 / QRA2	BT300 / QRA2
Auxiliary voltage	1NPE AC 230 V - 50 Hz TN-S	1NPE AC 230 V - 50 Hz TN-S	1NPE AC 230 V - 50 Hz
Power supply	3PE AC 400 V - 50 Hz	3PE AC 400 V - 50 Hz	3PE AC 400 V - 50 Hz
Fan motor	50 Hz - 7,5 kW	50 Hz - 7,5 kW	50 Hz - 11 kW
Acoustic level	<83 dB(A)	<81 dB(A)	<85 dB(A)
CE certificate	0085CL0215	0085CL0215	0085CL0215
Burner codes (body + head)	KN	3754048	3756103
	KM	3754052	3756104
	KL	3754056	3756105

GAS TRAINS

DUNGS

Model	Code
GT-d452-1"1/2 (*)	3750510
GT-d453-2" (*)	3750511
GT-d454-65	3750512
GT-d455-80	3750513
GT-d456-100	3750514

*: integrated filter

SIEMENS

Model	Code
GT-s451-1"1/2	3750525
GT-s452-2"	3750526
GT-s453-65	3750527
GT-s454-80	3750528
GT-s455-100	3750529
GT-s456-125	3750530

FILTERS

Model	Code
FG-Rp1"1/2	3757199
FG-Rp2"	3757200
FG-DN65	3757198
FG-DN80	3757201
FG-DN100	3757195
FG-DN125	3757209

Pressure drops graphs: see following pages
Dimensions of gas trains and gas filters: see pag. 206



DIMENSIONS (mm)

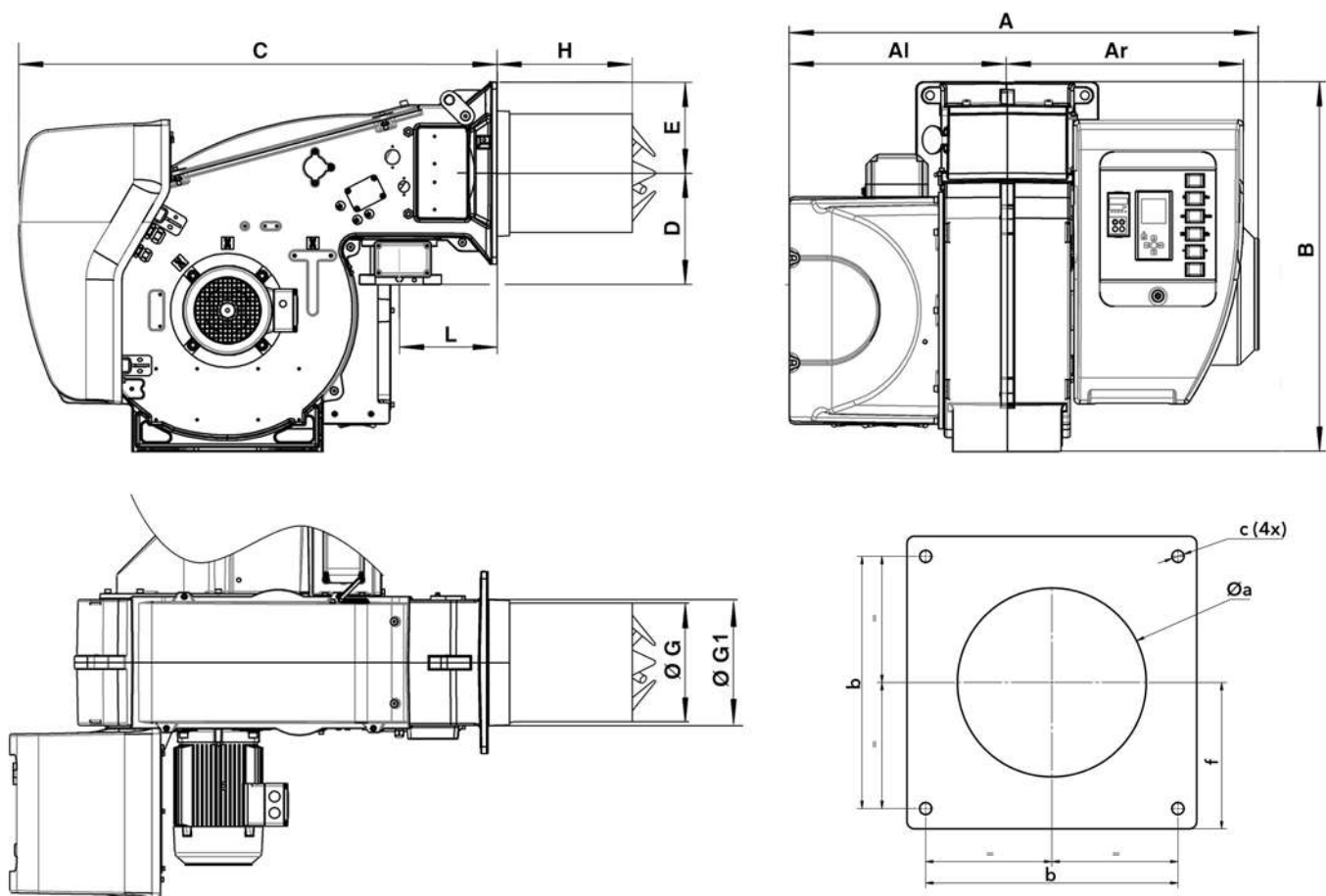

Model	A	Al	Ar	B	C	D	E	ØG	ØG1	H			L	Øa	b	c	f
										KN	KM	KL					
EK EVO 7.3600/4500	1096	509	587	941	1120	276	235	324	338	420	550	680	225	360-400	400	M16	235
EK EVO 7.5800	1205	510	695	941	1171	276	235	324	338	420	550	680	225	360-400	400	M16	235

PACKAGING

The burner is delivered on a pallet in 2 packages containing:

- burner body with mounted combustion head, boiler fixing accessories and technical documentation;
- gas train and filter.

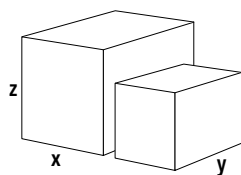

Models	Dimensions (mm)			Gross weight (kg)	
	X	Y	Z		
EK EVO 7.3600 G-EF3	KN	2070	1420	1130	218
	KM	2070	1420	1130	220
	KL	2070	1420	1130	222
EK EVO 7.4500 G-EF3	KN	2070	1420	1130	218
	KM	2070	1420	1130	220
	KL	2070	1420	1130	222
EK EVO 7.5800 G-EF3	KN	2070	1420	1130	360
	KM	2070	1420	1130	365
	KL	2070	1420	1130	370

PRESSURE LOSSES (BURNER HEAD + GAS TRAIN)

EK EVO 7.3600 G-EF3

DUNGS

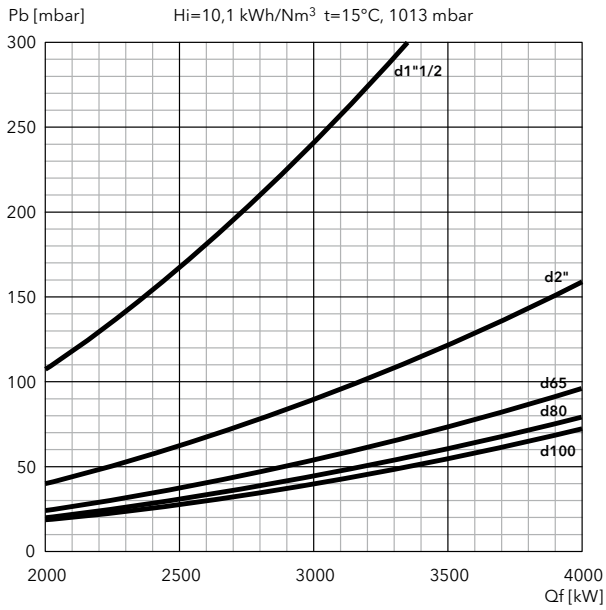

SIEMENS

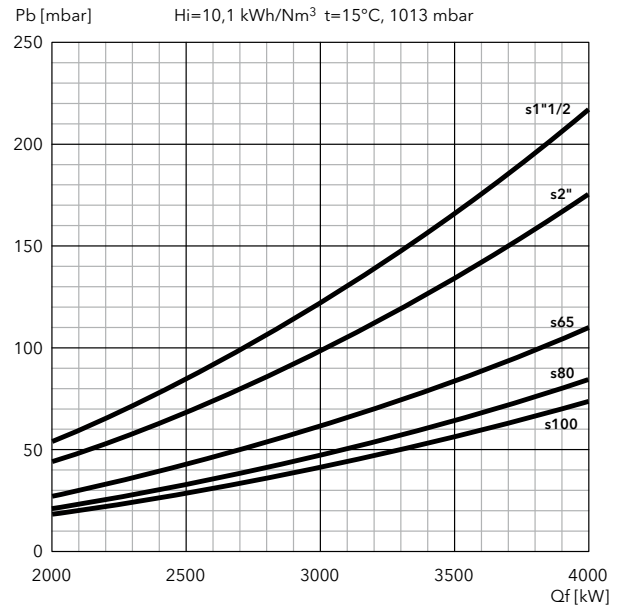

EK EVO 7.4500 G-EF3

DUNGS

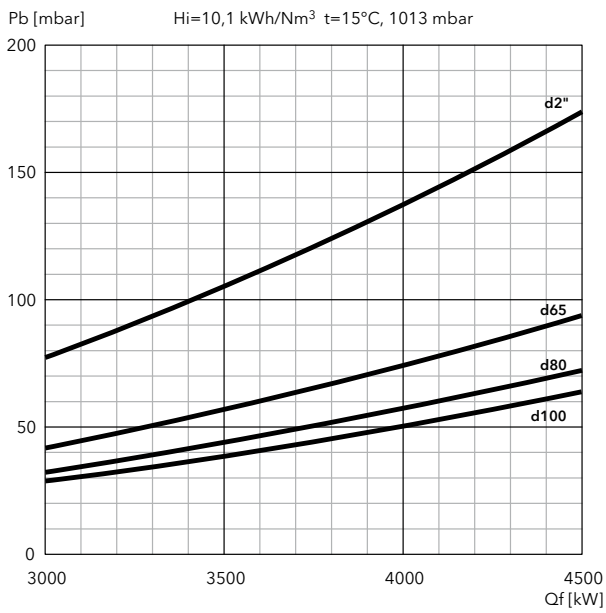

SIEMENS

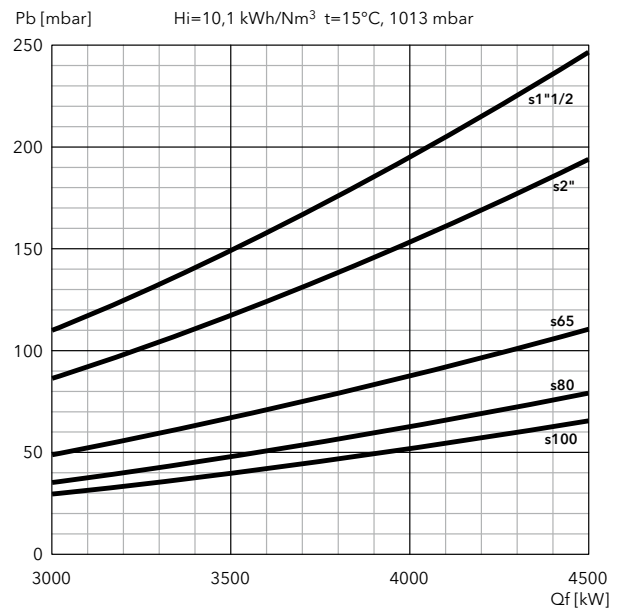

FILTERS

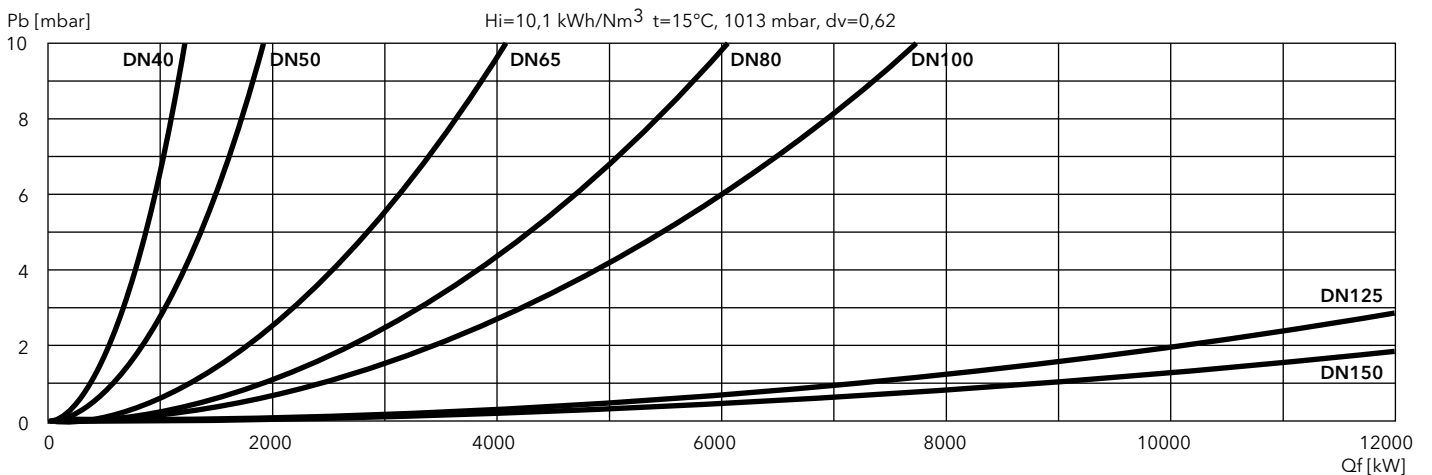

PRESSURE LOSSES (BURNER HEAD + GAS TRAIN)

EK EVO 7.5800 G-EF3

DUNGS

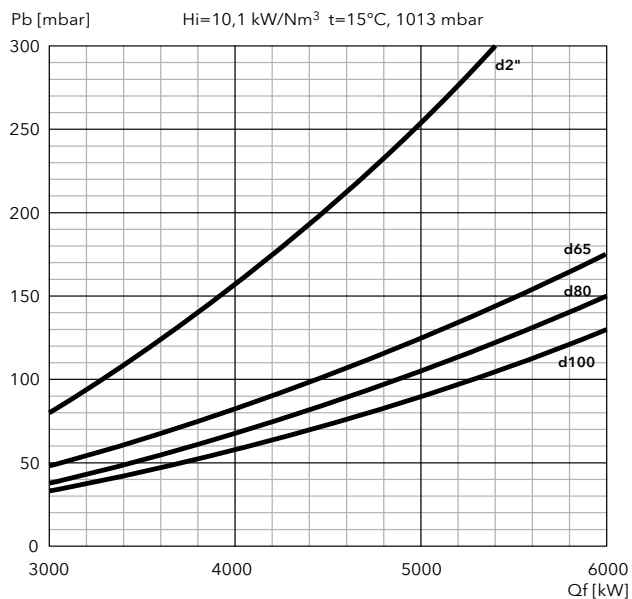

SIEMENS

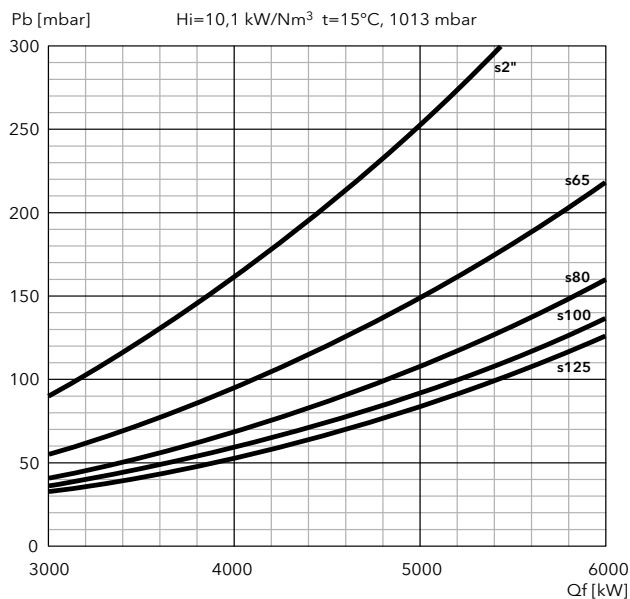

FILTERS

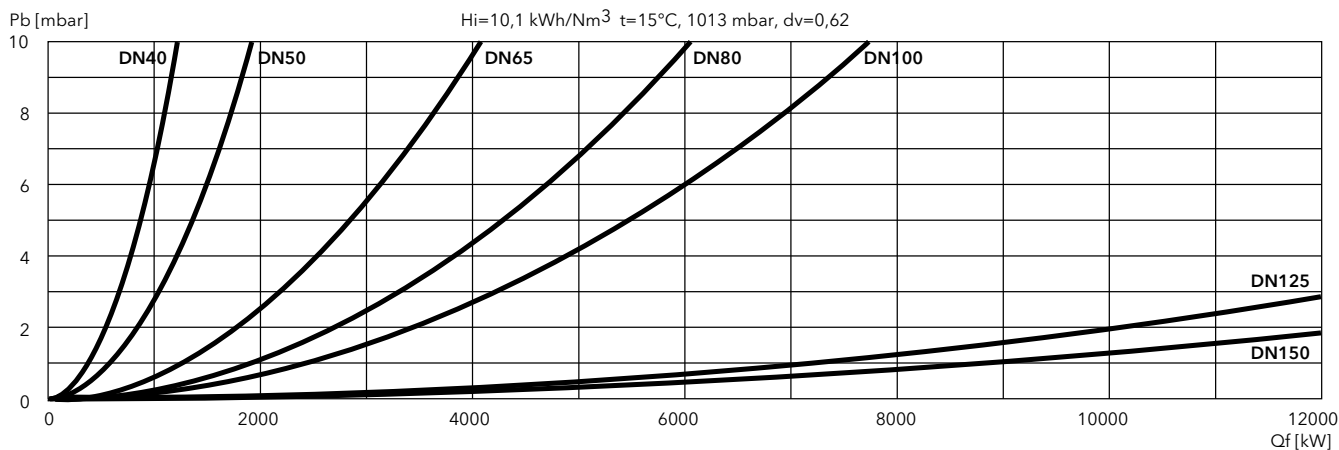

EKEVO 7 G-EU3

610 ... 7450 kW

2 stage progressive/modulating electronic (Low NOx class 3)

- **Fuels:** natural gas, Hi = 6,99 ... 11,39 kWh/Nm³;
LPG, Hi = 25,89 kWh/Nm³
- **Emission class:** Low NOx class 3 (≤80 mg/kWh) according to EN676
Version with FGR System (≤30 mg/kWh) available on request
- **Protection level:** IP 41



TECHNICAL DATA

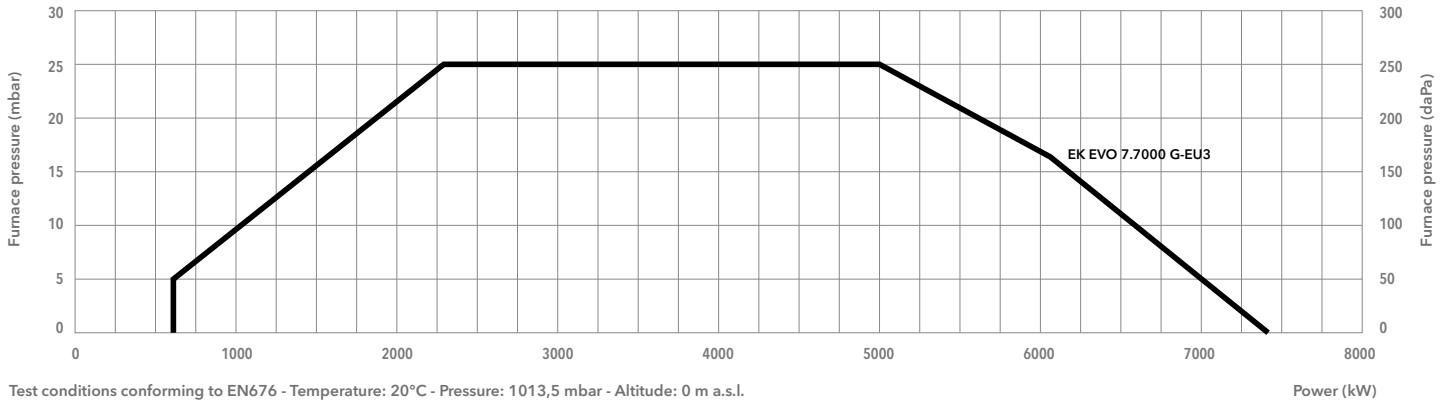

		EK EVO 7.7000 G-EU3
Operating range		610 - 7450 kW
Gas pressure		105 - 500 mbar (105 - 360 mbar for d452 and d453)
Gas connection		DN65
Control box / flame detector		BT300 / KLC
Auxiliary voltage		1NPE AC 230 V - 50 Hz
Power supply		3PE AC 400 V - 50 Hz
Fan motor		50 Hz - 15 kW
Acoustic level		<89 dB(A)
CE certificate		0085CL0215
Burner codes (body + head)	KN	3758210
	KM	3758211
	KL	3758212

GAS TRAINS

DUNGS

Model	Code
GT-d453-2" (*)	3750511
GT-d454-65	3750512
GT-d455-80	3750513
GT-d456-100	3750514

*: integrated filter

SIEMENS

Model	Code
GT-s452-2"	3750526
GT-s453-65	3750527
GT-s454-80	3750528
GT-s455-100	3750529
GT-s456-125	3750530

FILTERS

Model	Code
FG-Rp2"	3757200
FG-DN65	3757198
FG-DN80	3757201
FG-DN100	3757195
FG-DN125	3757209

Pressure drops graphs: see following pages
Dimensions of gas trains and gas filters: see pag. 206



DIMENSIONS (mm)

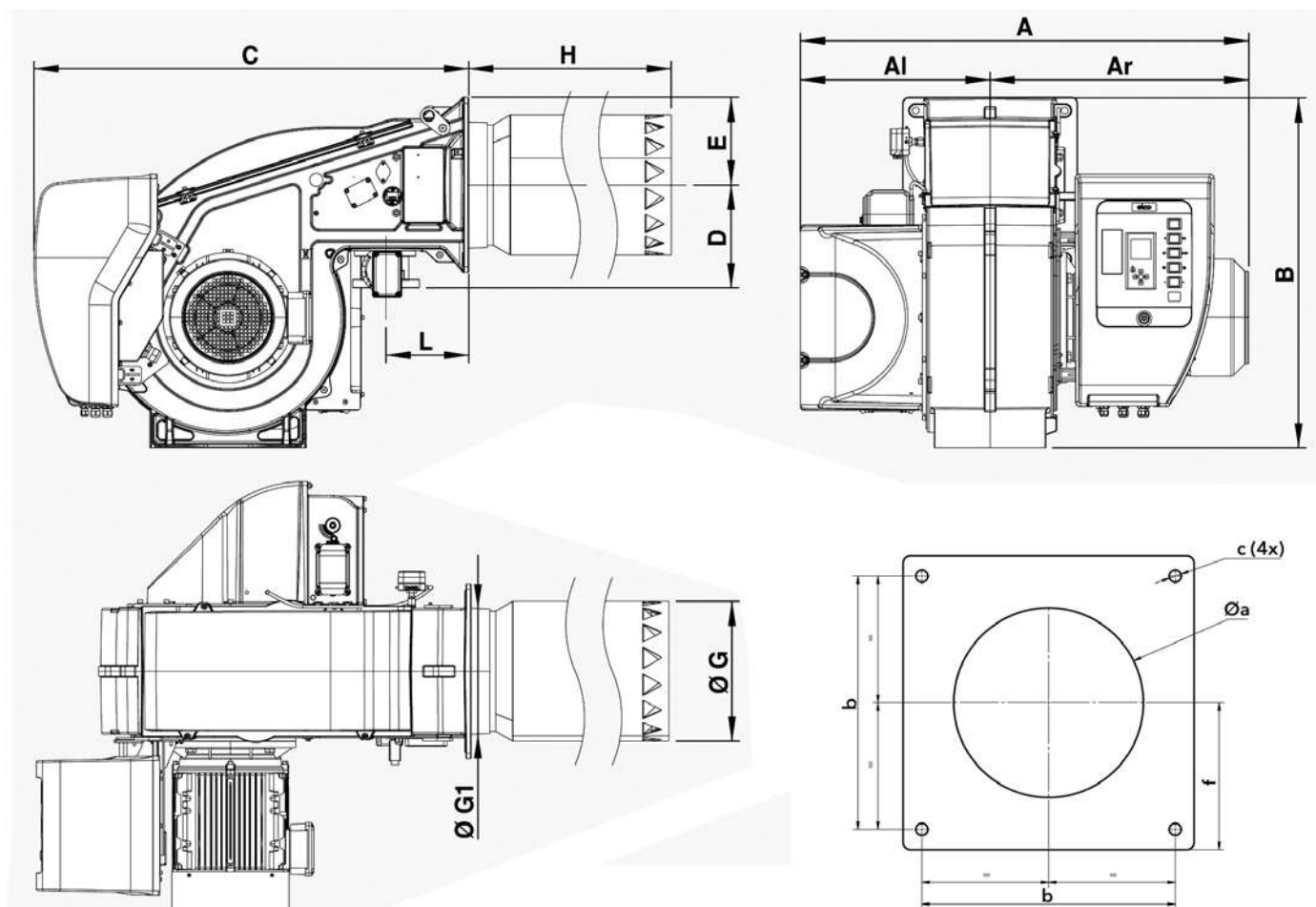

Model	A	Al	Ar	B	C	D	E	ØG	ØG1	H			L	Øa	b	c	f
										KN	KM	KL					
EKEVO 7.7000	1205	510	695	941	1168	276	235	376	340	501	641	781	225	390-400	400	M16	235

PACKAGING

The burner is delivered on a pallet in 2 packages containing:

- burner body with mounted combustion head, boiler fixing accessories and technical documentation;
- gas train and filter.

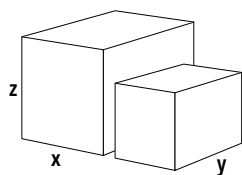

Models	Dimensions (mm)			Gross weight (kg)	
	X	Y	Z		
EK EVO 7.7000 G-EU3	KN	2070	1420	1130	218
	KM	2070	1420	1130	220
	KL	2070	1420	1130	222

PRESSURE LOSSES (BURNER HEAD + GAS TRAIN)

EK EVO 7.7000 G-EU3

DUNGS

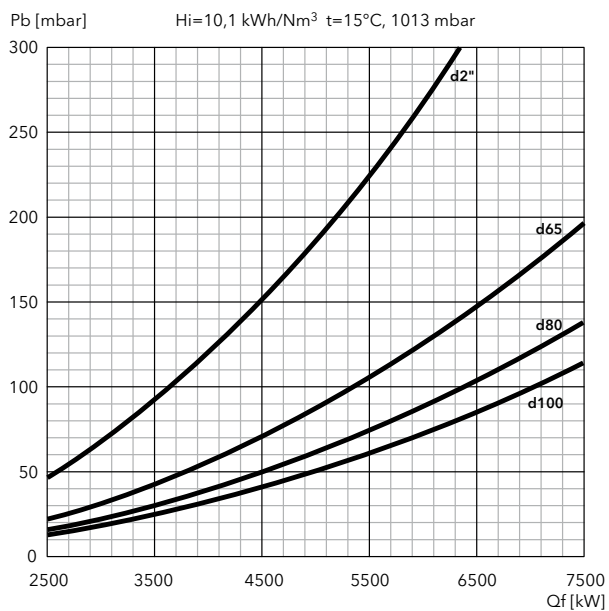

SIEMENS

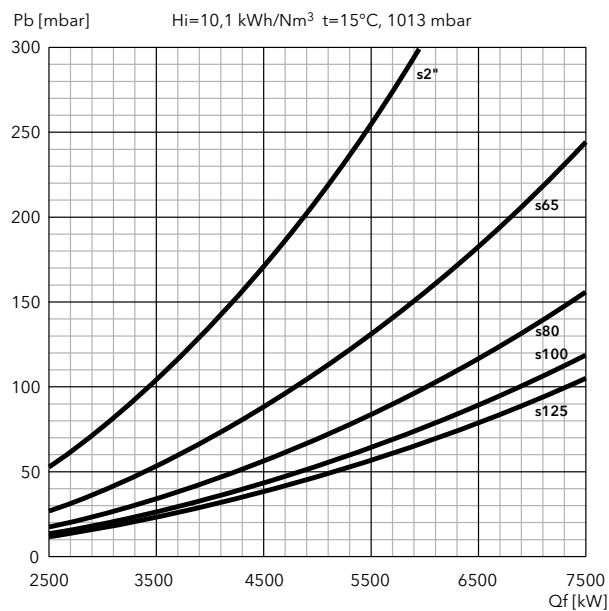

PRESSURE LOSSES (BURNER HEAD + GAS TRAIN)

FILTERS

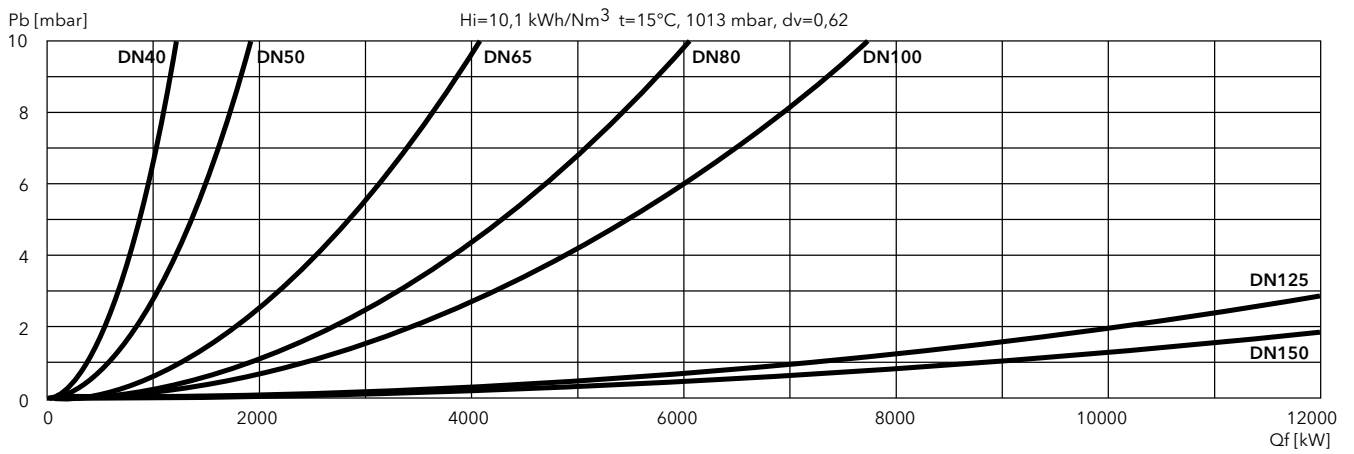

EKEVO 8 G-EU3, EKEVO 9 G-EU3

600 ... 10500 kW

2 stage progressive/modulating electronic (Low NOx class 3)

- **Fuels:** natural gas, Hi = 6,99 ... 11,39 kWh/Nm³;
LPG, Hi = 25,89 kWh/Nm³
- **Emission class:** Low NOx class 3 (≤80 mg/kWh) according to EN676
Version with FGR System (≤30 mg/kWh) available on request
- **Protection level:** IP 41

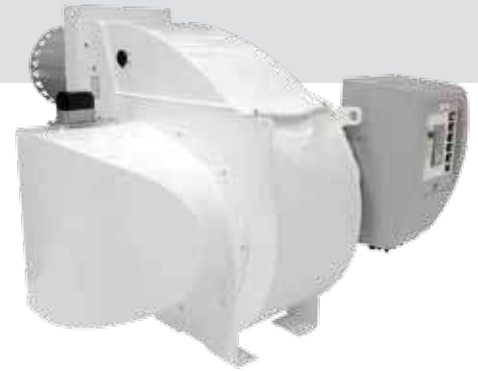

TECHNICAL DATA

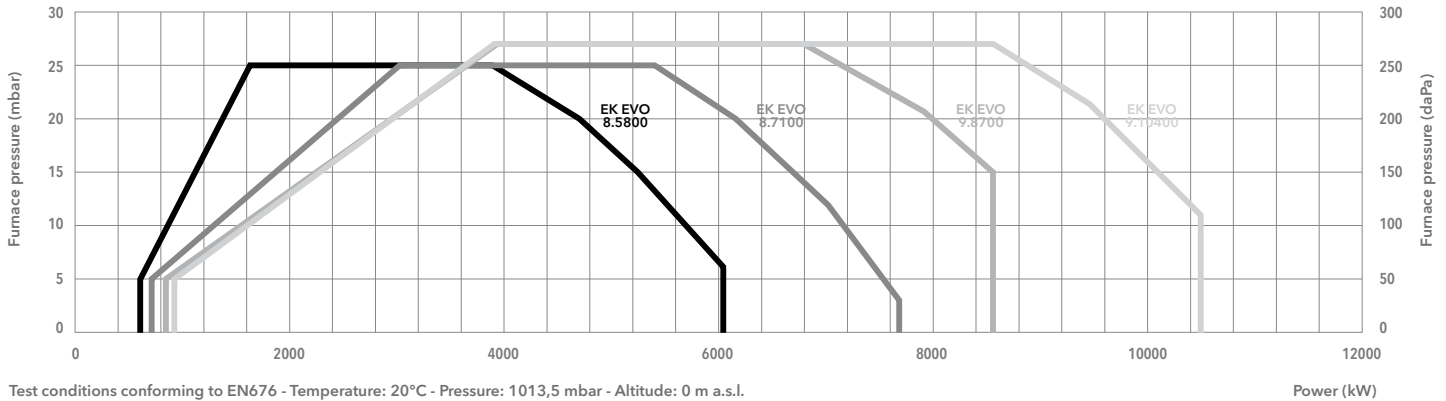

Test conditions conforming to EN676 - Temperature: 20°C - Pressure: 1013,5 mbar - Altitude: 0 m a.s.l.

	EKEVO 8.5800 G-EU3	EKEVO 8.7100 G-EU3	EKEVO 9.8700 G-EU3	EKEVO 9.10400 G-EU3
Operating range	600 - 6070 kW	700 - 7700 kW	850 - 8530 kW	910 - 10500 kW
Gas pressure	70 - 500 mbar (70 - 360 mbar for d457)		80 - 500 mbar (80 - 360 mbar for d457)	
Gas connection	DN100	DN100	DN100	DN100
Control box / flame detector	BT300 / Ionisation		BT300 / Ionisation	
Auxiliary voltage	1NPE AC 230 V - 50 Hz TN-S		1NPE AC 230 V - 50 Hz TN-S	
Power supply	3PE AC 400 V - 50 Hz		3PE AC 400 V - 50 Hz	
Fan motor	50 Hz - 11 kW	50 Hz - 15 kW	50 Hz - 18,5 kW	50 Hz - 22 kW
Acoustic level	<80,2 dB(A)	<82,3 dB(A)	<85,4 dB(A)	<86,1 dB(A)
CE certificate	0085CL0215		0085CL0215	
Burner codes (body + head)	KN	3753969	3753970	3753971
	KM	3753978	3753979	3753980
	KL	3753986	3753987	3753988

GAS TRAINS

DUNGS

Model	Code
GT-d457-2" (*)	3750515
GT-d458-65	3750516
GT-d459-80	3750517
GT-d460-100	3750518

*: integrated filter

SIEMENS

Model	Code
GT-s457-2"	3750537
GT-s458-65	3750538
GT-s459-80	3750539
GT-s460-100	3750540
GT-s461-125	3750541

FILTERS

Model	Code
FG-Rp2"	3757200
FG-DN65	3757198
FG-DN80	3757201
FG-DN100	3757195
FG-DN125	3757209

 **Pressure drops graphs:** see following pages
Dimensions of gas trains and gas filters: see pag. 207



DIMENSIONS (mm)

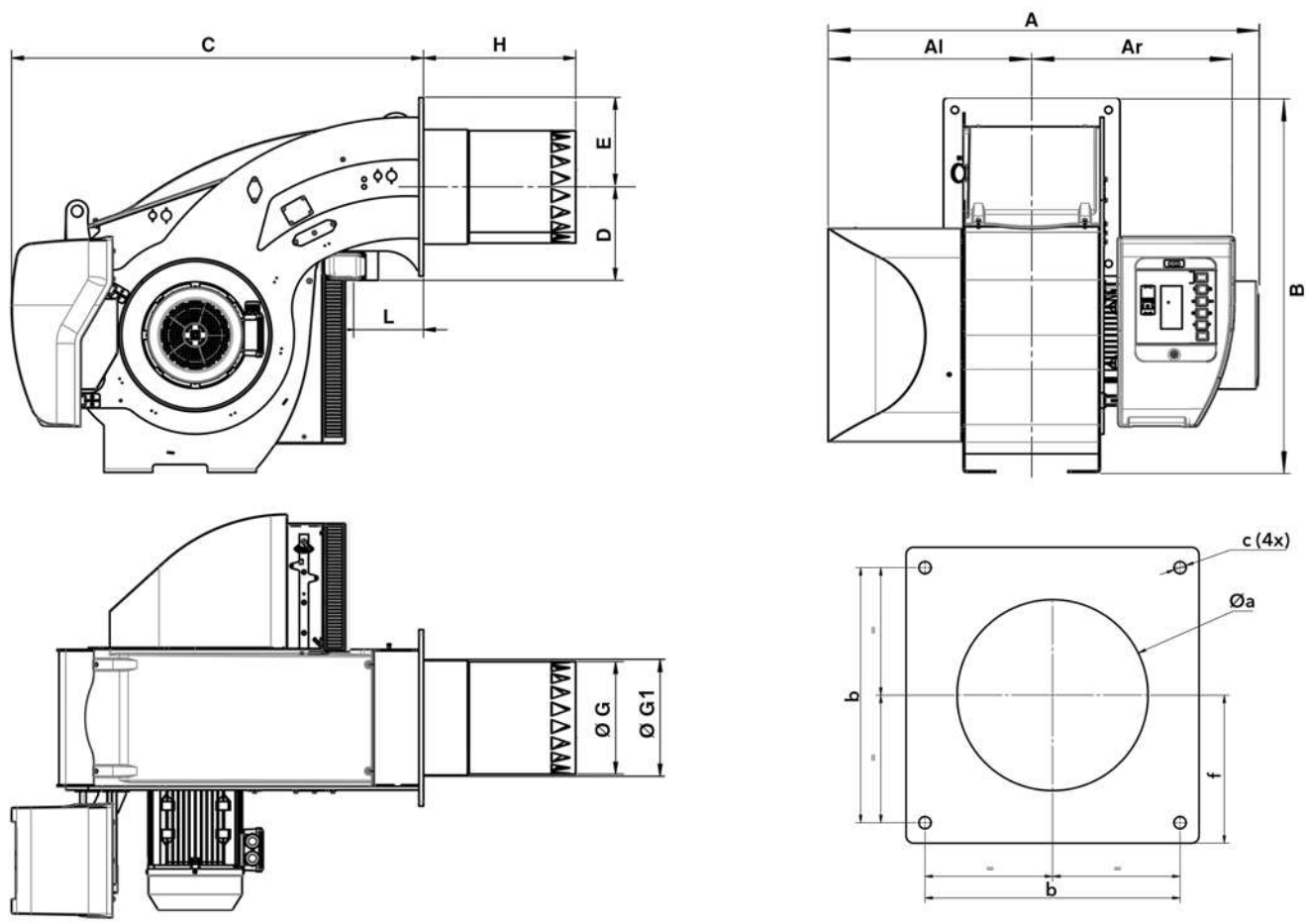

Model	A	Al	Ar	B	C	D	E	ØG	ØG1	H			L	Øa	b	c	f
										KN	KM	KL					
EK EVO 8.5800	1323	670	653	1231	1353	307	288	369	376	500	640	780	230	390-410	505	M20	293
EK EVO 8.7100	1323	670	653	1231	1353	307	288	369	376	500	640	780	230	390-410	505	M20	293
EKEVO 9.8700	1334	670	653	1291	1350	332	293	432	439	550	700	850	230	460-480	505	M20	293
EK EVO 9.10400	1401	670	653	1291	1350	332	293	432	439	550	700	850	230	460-480	505	M20	293

PACKAGING

- The burner is delivered on a pallet in 2 packages containing:
- burner body with mounted combustion head, boiler fixing accessories and technical documentation;
 - gas train and filter.

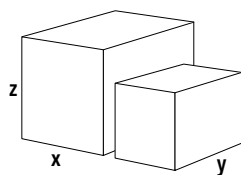

Models		Dimensions (mm)			Gross weight (kg)
		X	Y	Z	
EK EVO 8.5800 G-EU3	KN	2300	1500	1396	481
	KM	2300	1500	1396	487
	KL	2300	1500	1396	498
EK EVO 8.7100 G-EU3	KN	2300	1500	1396	497
	KL	2300	1500	1396	514
EK EVO 9.8700 G-EU3	KN	2300	1500	1461	524
	KM	2300	1500	1461	532
	KL	2300	1500	1461	539
EK EVO 9.10400 G-EU3	KN	2300	1500	1461	546
	KM	2300	1500	1461	553
	KL	2300	1500	1461	565

PRESSURE LOSSES (BURNER HEAD + GAS TRAIN)

EK EVO 8.5800 G-EU3

DUNGS

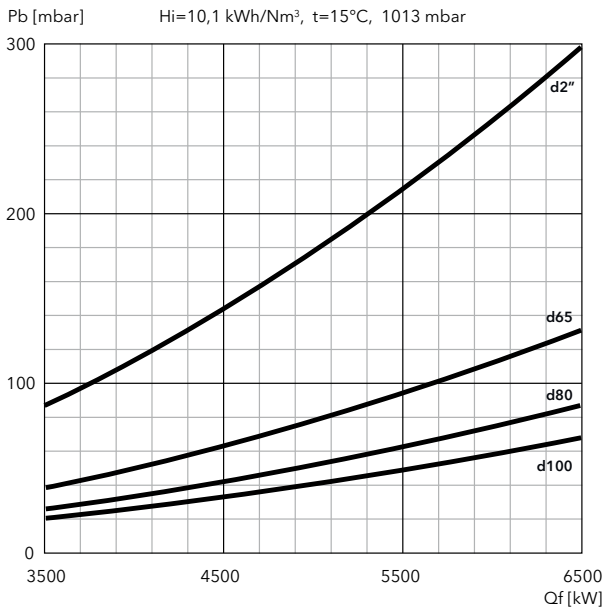

SIEMENS

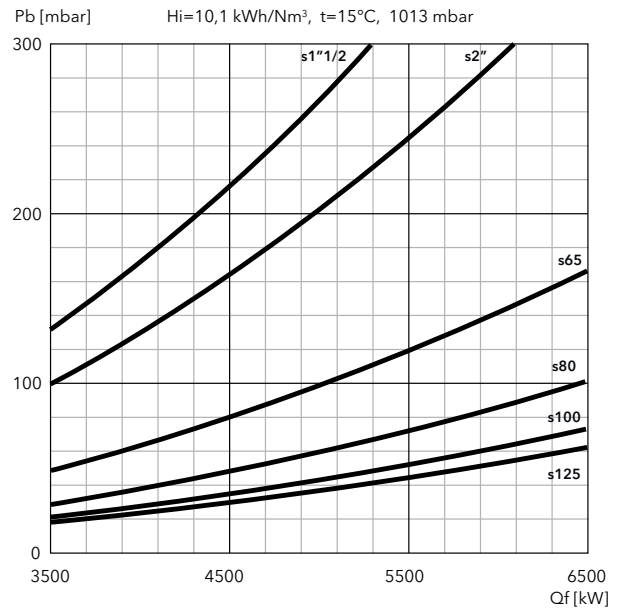

EK EVO 8.7100 G-EU3

DUNGS

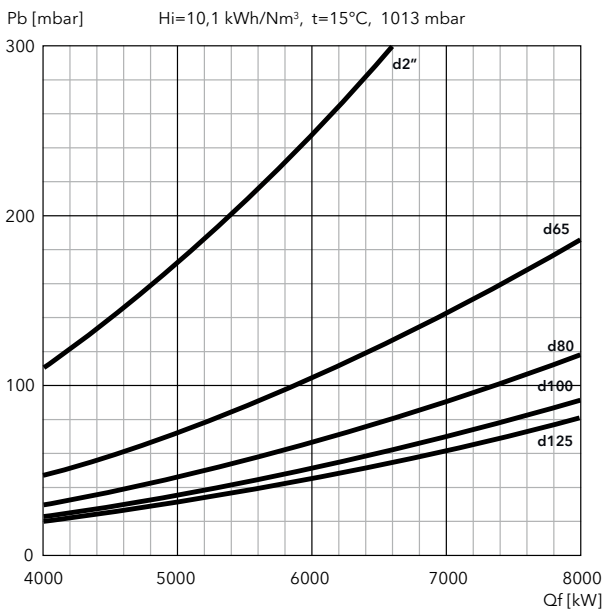

SIEMENS

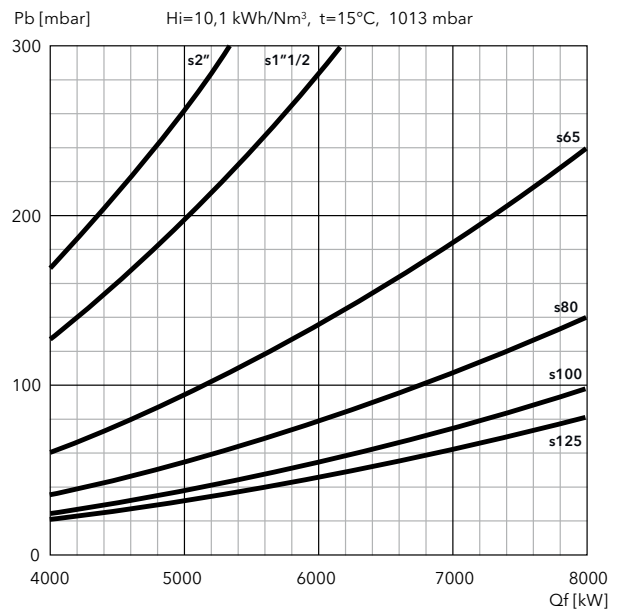

FILTERS

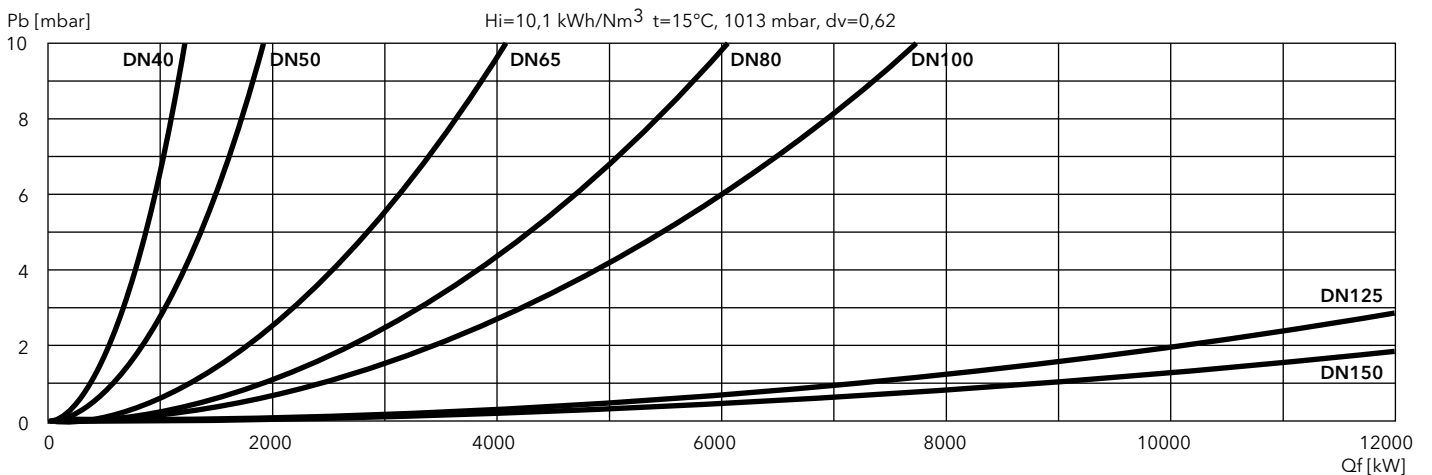

PRESSURE LOSSES (BURNER HEAD + GAS TRAIN)

EK EVO 9.8700 G-EU3

DUNGS

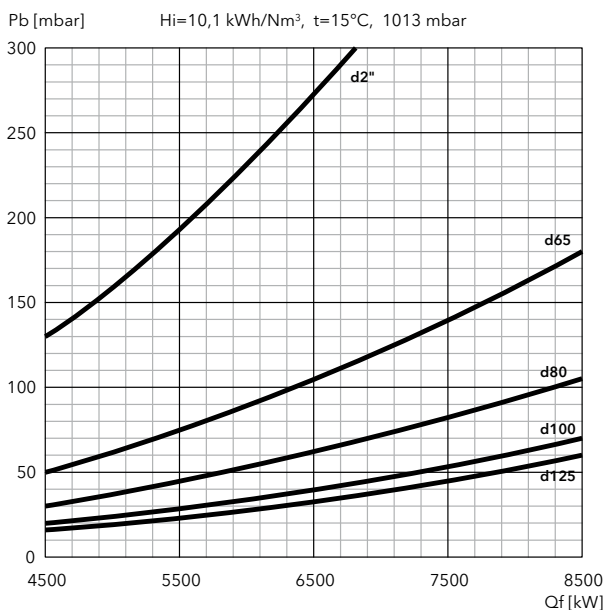

SIEMENS

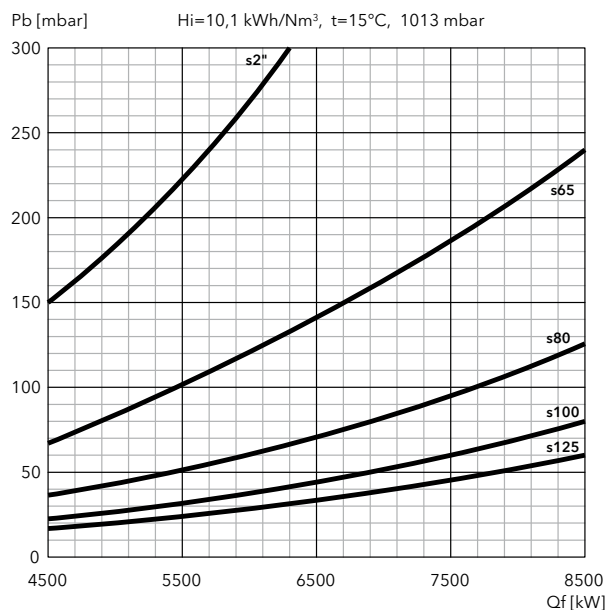

EK EVO 9.10400 G-EU3

DUNGS

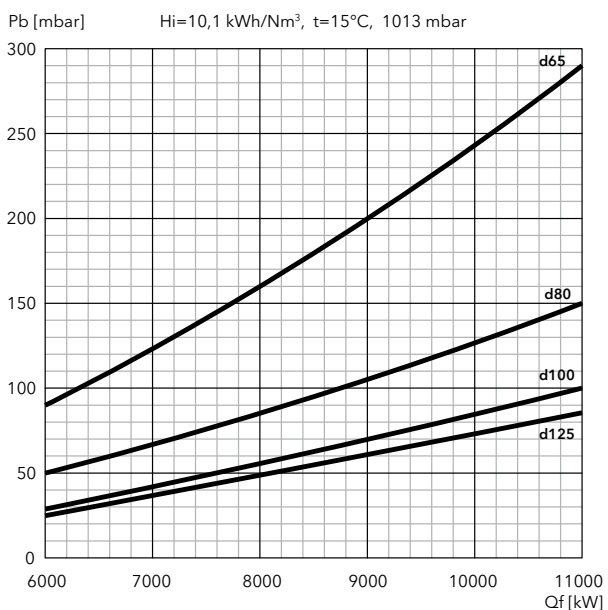

SIEMENS

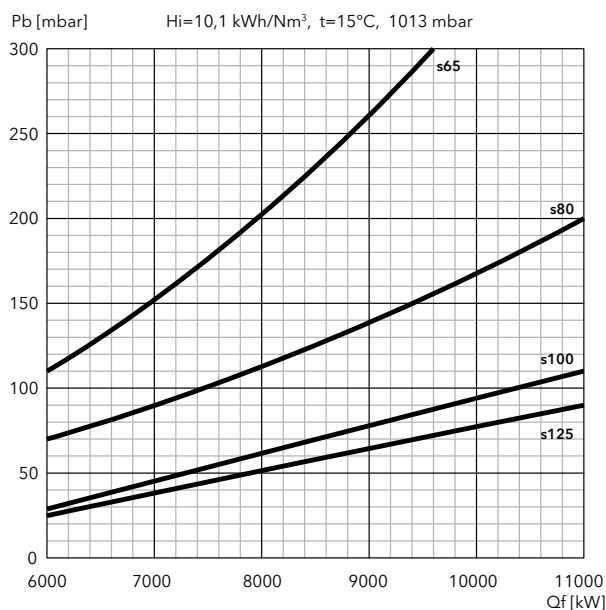

FILTERS

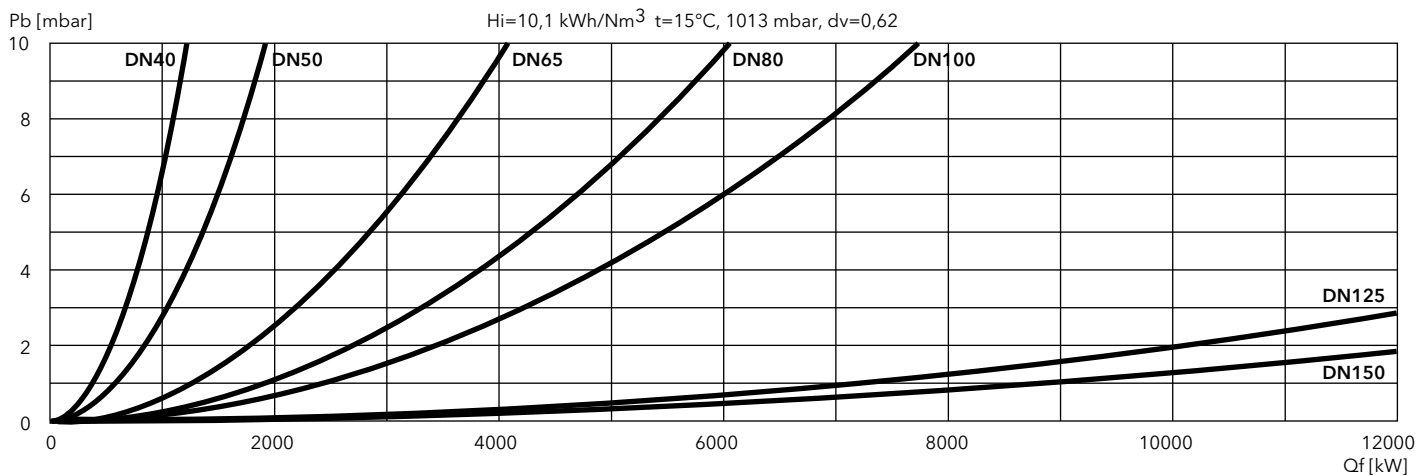

EKEVO 9 G-EU3

1350 ... 13500 kW

2 stage progressive/modulating electronic (Low NOx class 3)

- **Fuels:** natural gas, Hi = 6,99 ... 11,39 kWh/Nm³;
LPG, Hi = 25,89 kWh/Nm³
- **Emission class:** Low NOx class 3 (≤80 mg/kWh) according to EN676
Version with FGR System (≤30 mg/kWh) available on request
- **Protection level:** IP 41



TECHNICAL DATA

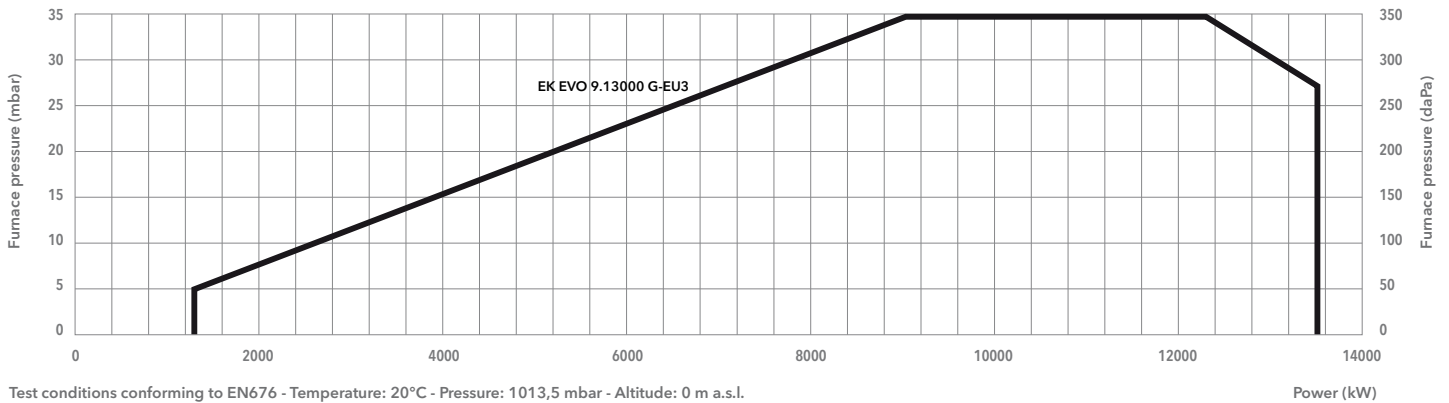

Test conditions conforming to EN676 - Temperature: 20°C - Pressure: 1013,5 mbar - Altitude: 0 m a.s.l.

		EKEVO 9.13000 G-EU3
Operating range		1350 - 13500 kW
Gas pressure		130 - 500 mbar (130 - 360 mbar for d457)
Gas connection		DN100
Control box / flame detector		BT300 / KLC
Auxiliary voltage		1NPE AC 230 V - 50/60 Hz
Power supply		3PE AC 400 V - 50 Hz
Fan motor		50 Hz - 37 kW
Acoustic level		<93,5 dB(A)
CE certificate		0085CL0215
Burner codes (body + head)	KN	3758162
	KM	3758163
	KL	3758164

GAS TRAINS

DUNGS

Model	Code
GT-d459-80	3750517
GT-d460-100	3750518
GT-d4...-125	on request

SIEMENS

Model	Code
GT-s459-80	3750539
GT-s460-100	3750540
GT-s461-125	3750541
GT-s4...-150	on request

FILTERS

Model	Code
FG-DN80	3757201
FG-DN100	3757195
FG-DN125	3757209
FG-DN150	3757210

 **Pressure drops graphs:** see following pages
Dimensions of gas trains and gas filters: see pag. 207



DIMENSIONS (mm)

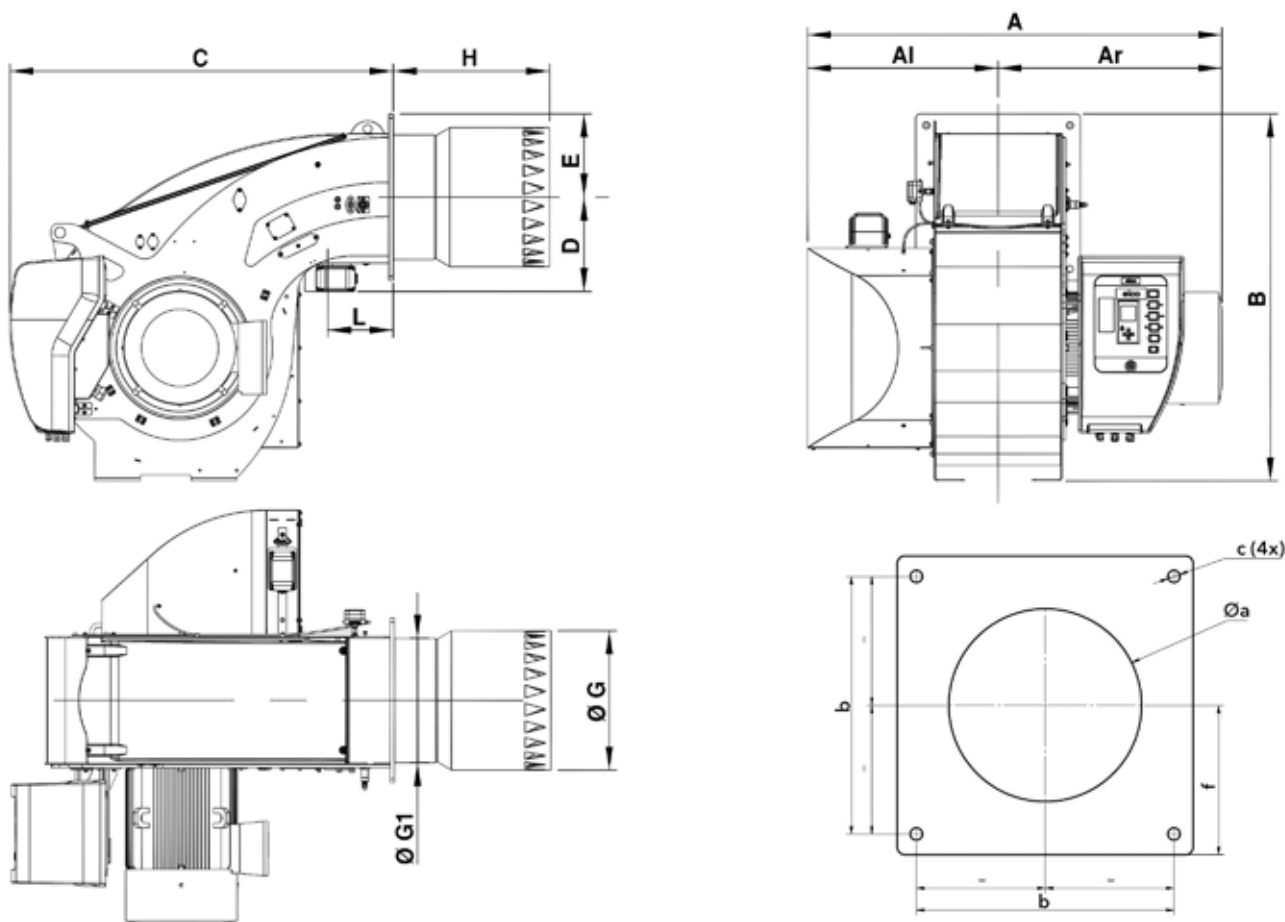

Model	A	Al	Ar	B	C	D	E	ØG	ØG1	H			L	Øa	b	c	f
										KN	KM	KL					
EKEVO 9.13000	1457	670	788	1291	1350	332	293	490	439	550	700	850	230	510-520	505	M20	293

PACKAGING

The burner is delivered on a pallet in 2 packages containing:

- burner body with mounted combustion head, boiler fixing accessories and technical documentation;
- gas train and filter.

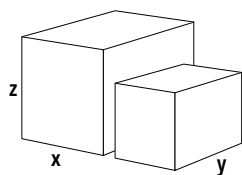

Models	Dimensions (mm)			Gross weight (kg)	
	X	Y	Z		
EK EVO 9.13000 G-EU3	KN	2300	1500	1461	546
	KM	2300	1500	1461	553
	KL	2300	1500	1461	565

PRESSURE LOSSES (BURNER HEAD + GAS TRAIN)

EK EVO 9.13000 G-EU3

DUNGS

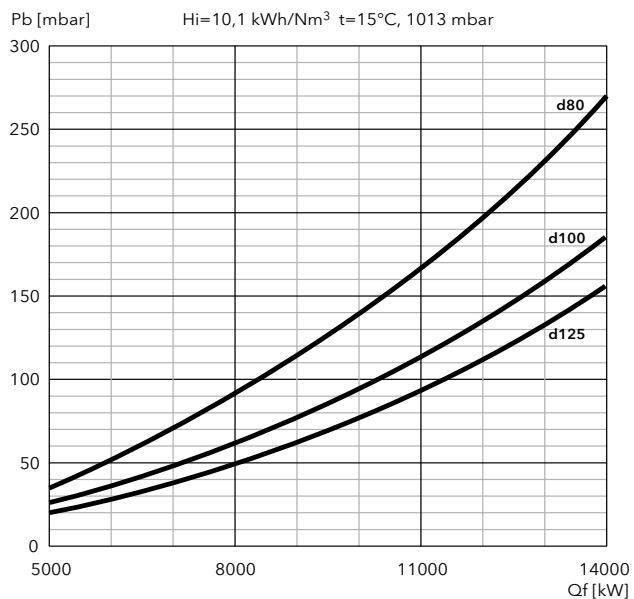

SIEMENS

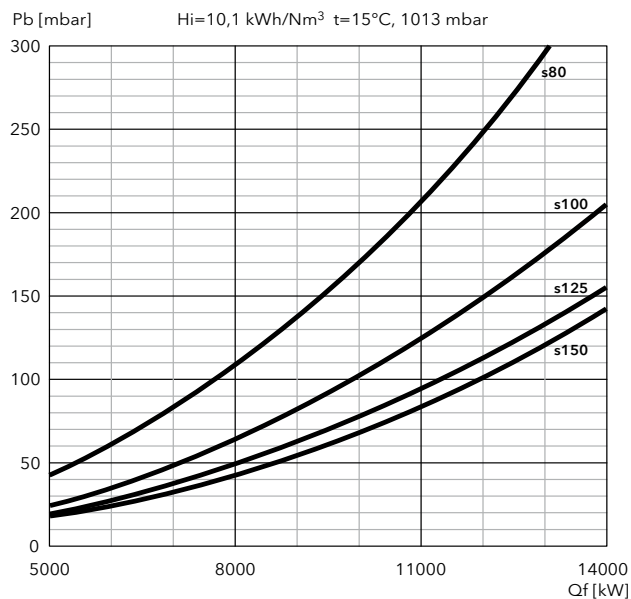

PRESSURE LOSSES (BURNER HEAD + GAS TRAIN)

FILTERS

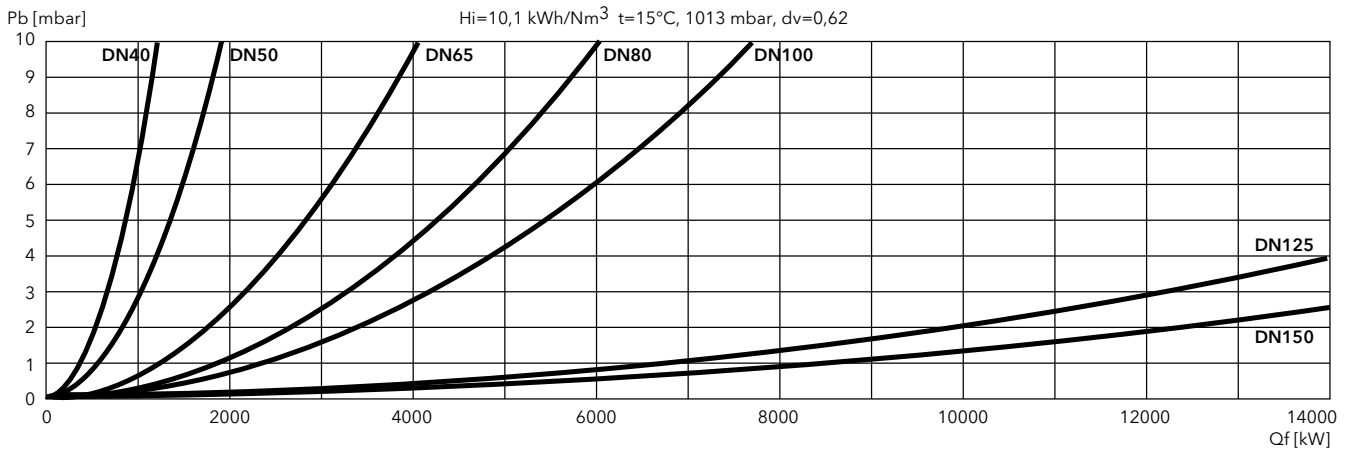

EKEVO 6 GL-EZ3, EKEVO 7 GL-EZ3

290 ... 4740 kW

2 stage progressive/modulating electronic in gas / 3 stages in light oil

- **Fuels:** natural gas, Hi = 6,99 ... 11,39 kWh/Nm³;
light oil, viscosity 6 mm²/s at 20°C, Hi = 11,86 kWh/kg
- **Emission class:** Low NOx class 2 (≤120 mg/kWh) according to EN676 in gas
Low NOx class 2 (≤185 mg/kWh) according to EN267 in light oil
- **Protection level:** IP 41

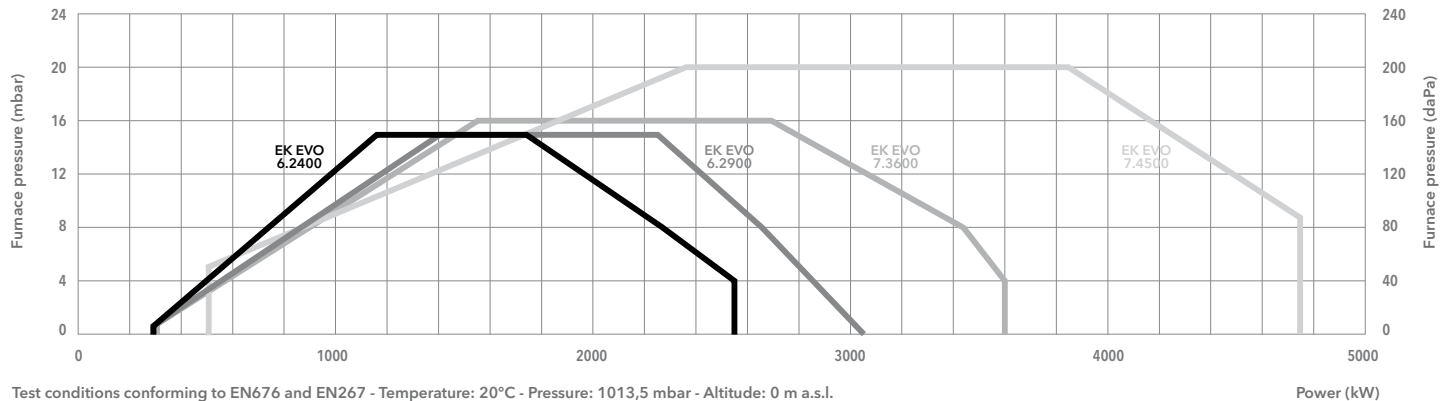
TECHNICAL DATA

Test conditions conforming to EN676 and EN267 - Temperature: 20°C - Pressure: 1013,5 mbar - Altitude: 0 m a.s.l.

	EK EVO 6.2400 GL-EZ3	EK EVO 6.2900 GL-EZ3	EK EVO 7.3600 GL-EZ3	EK EVO 7.4500 GL-EZ3
Operating range gas	290 - 2550 kW	290 - 3050 kW	300 - 3600 kW	510 - 4740 kW
Operating range oil	730 - 2470 kW	730 - 2790 kW	1090 - 3600 kW	1300 - 4740 kW
Gas pressure	50 - 500 mbar (50 - 360 mbar for d452 and d453)		50 - 500 mbar (50 - 360 mbar for d452 and d453)	
Gas connection	DN65	DN65	DN65	DN65
Control box / flame detector	BT300 / QRA2	BT300 / QRA2	BT300 / QRA2	BT300 / QRA2
Auxiliary voltage	1NPE AC 230 V - 50 Hz TN-S	1NPE AC 230 V - 50 Hz TN-S	1NPE AC 230 V - 50 Hz TN-S	1NPE AC 230 V - 50 Hz TN-S
Power supply	3PE AC 400 V - 50 Hz	3PE AC 400 V - 50 Hz	3PE AC 400 V - 50 Hz	3PE AC 400 V - 50 Hz
Fan motor	50 Hz - 3 kW	50 Hz - 4 kW	50 Hz - 5,5 kW	50 Hz - 7,5 kW
Acoustic level	<75 dB(A)	<77 dB(A)	<81 dB(A)	<82,5 dB(A)
CE certificate	0085CL0215	0085CL0215	0085CL0215	0085CL0215
Burner codes (body + head)	KN	3754106	3754107	3754109
	KM	3754110	3754111	3754113
	KL	3754114	3754115	3754117

GAS TRAINS
DUNGS

Model	Code
GT-d452-1"1/2 (*)	3750510
GT-d453-2" (*)	3750511
GT-d454-65	3750512
GT-d455-80	3750513
GT-d456-100	3750514

*: integrated filter

SIEMENS

Model	Code
GT-s451-1"1/2	3750525
GT-s452-2"	3750526
GT-s453-65	3750527
GT-s454-80	3750528
GT-s455-100	3750529
GT-s456-125	3750530

FILTERS

Model	Code
FG-Rp1"1/2	3757199
FG-Rp2"	3757200
FG-DN65	3757198
FG-DN80	3757201
FG-DN100	3757195
FG-DN125	3757209

 **Pressure drops graphs:** see following pages
Dimensions of gas trains and gas filters: see pag. 206



DIMENSIONS (mm)

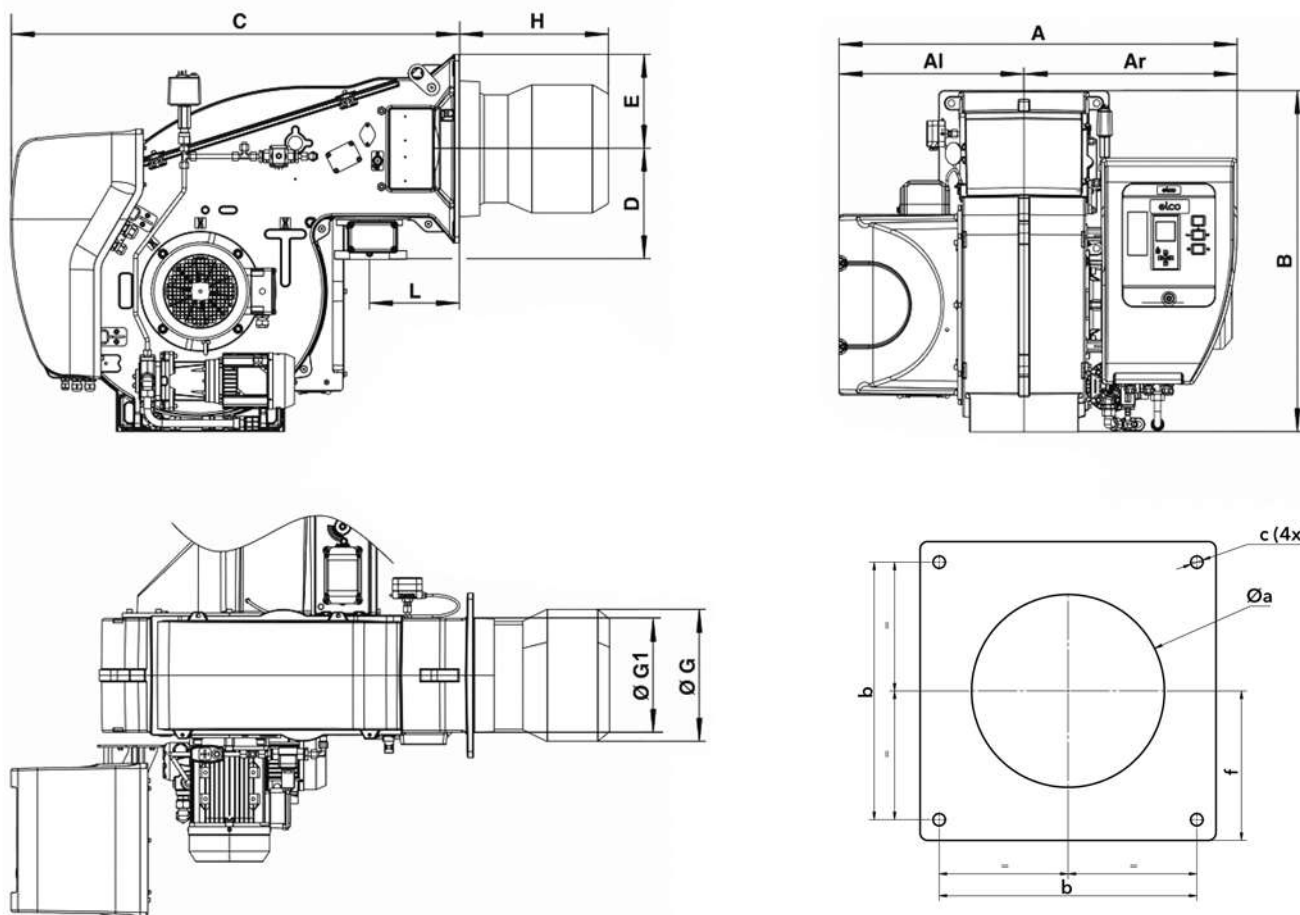

Model	A	Al	Ar	B	C	D	E	ØG	ØG1	H			L	Øa	b	c	f
										KN	KM	KL					
EK EVO 6.2400	1066	479	587	812	1050	245	200	320	262,5	330	450	570	215	330-340	340	M16	200
EK EVO 6.2900	1066	479	587	812	1050	245	200	320	262,5	330	450	570	215	330-340	340	M16	200
EK EVO 7.3600	1097	510	587	942	1130	276	235	320	270	375	505	635	225	390-400	400	M16	235
EK EVO 7.4500	1097	510	587	942	1130	276	235	370	308	375	505	635	225	390-400	400	M16	235

PACKAGING

The burner is delivered on a pallet in 2 packages containing:

- burner body with mounted combustion head, boiler fixing accessories and technical documentation;
- gas train and filter.

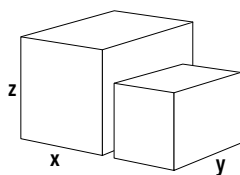

Models	Dimensions (mm)			Gross weight (kg)	
	X	Y	Z		
EK EVO 6.2400 GL-EZ3	KN	2070	1420	990	188
	KM	2070	1420	990	190
	KL	2070	1420	990	192
EK EVO 6.2900 GL-EZ3	KN	2070	1420	990	194
	KM	2070	1420	990	196
	KL	2070	1420	990	198
EK EVO 7.3600 GL-EZ3	KN	2070	1420	1130	237
	KM	2070	1420	1130	239
	KL	2070	1420	1130	241
EK EVO 7.4500 GL-EZ3	KN	2070	1420	1130	243
	KM	2070	1420	1130	245
	KL	2070	1420	1130	247

PRESSURE LOSSES (BURNER HEAD + GAS TRAIN)

EK EVO 6.2400 GL-EZ3

DUNGS

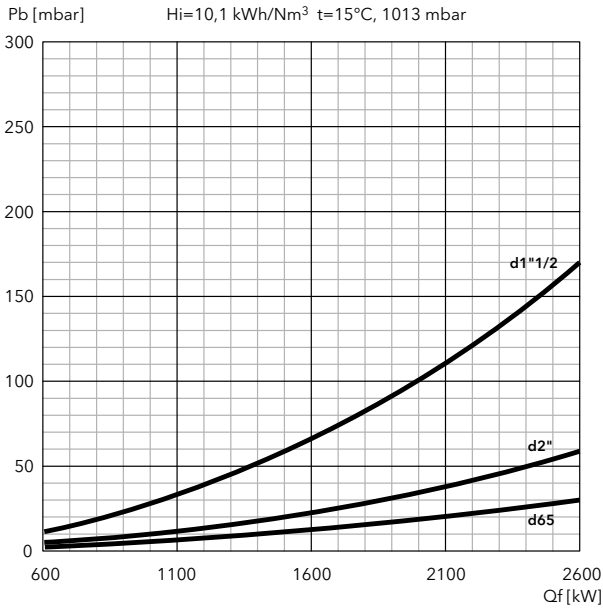

SIEMENS

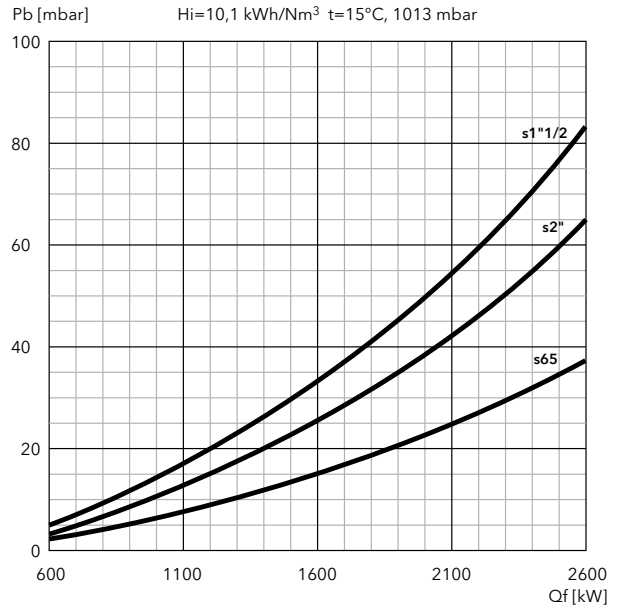

EK EVO 6.2900 GL-EZ3

DUNGS

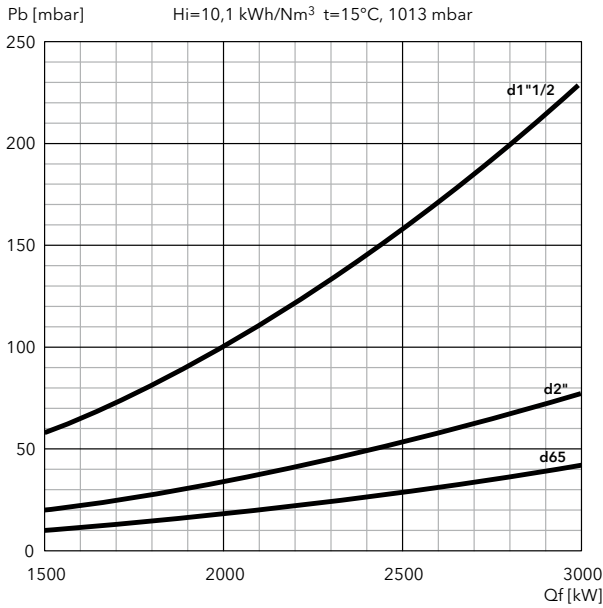

SIEMENS

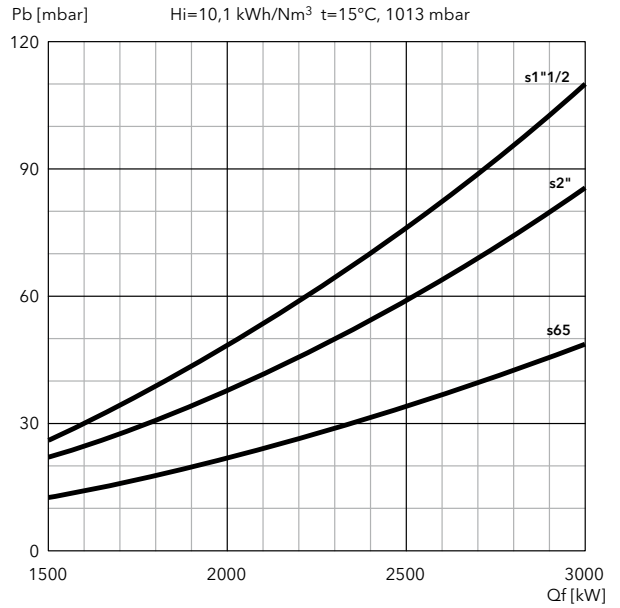

FILTERS

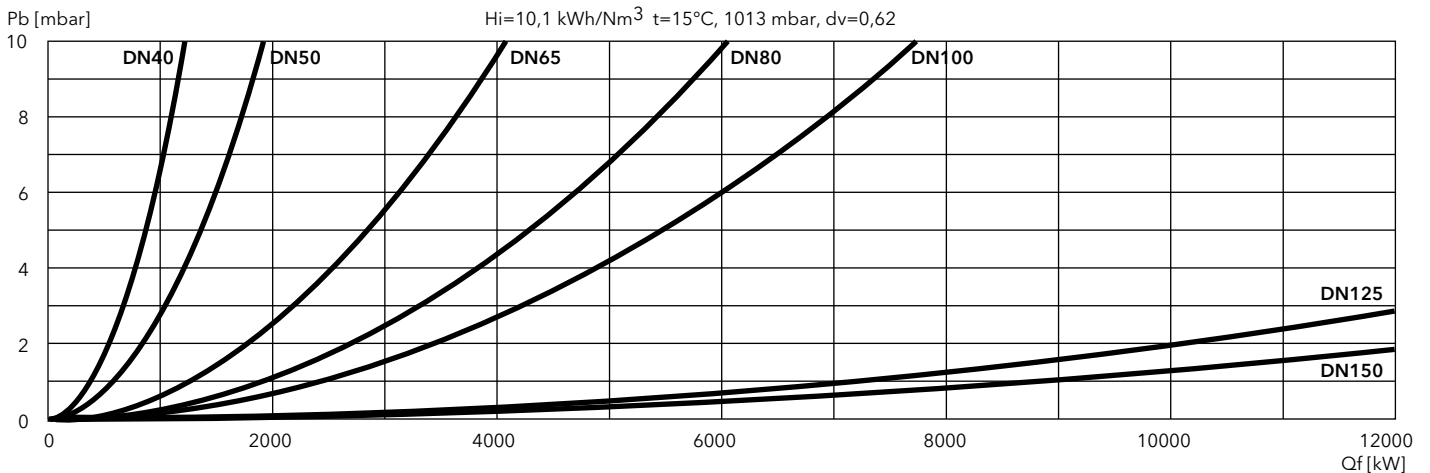

PRESSURE LOSSES (BURNER HEAD + GAS TRAIN)

EK EVO 7.3600 GL-EZ3

DUNGS

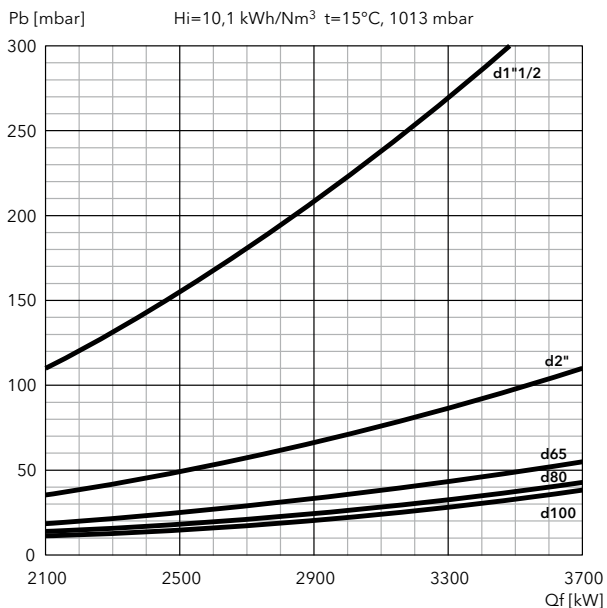

SIEMENS

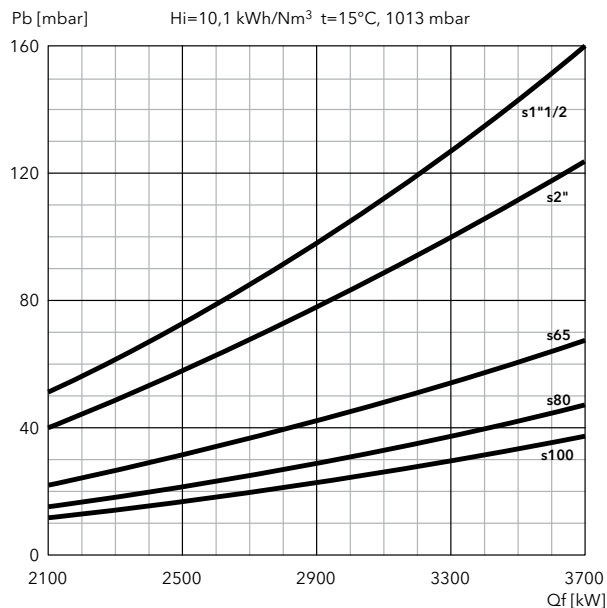

EK EVO 7.4500 GL-EZ3

DUNGS

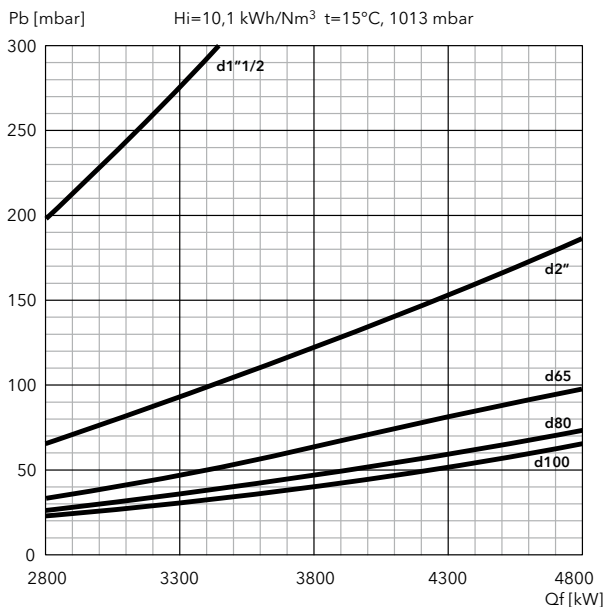

SIEMENS

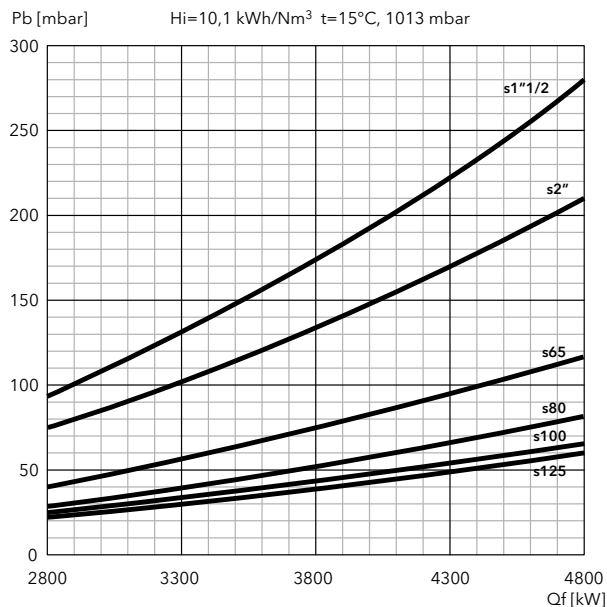

FILTERS

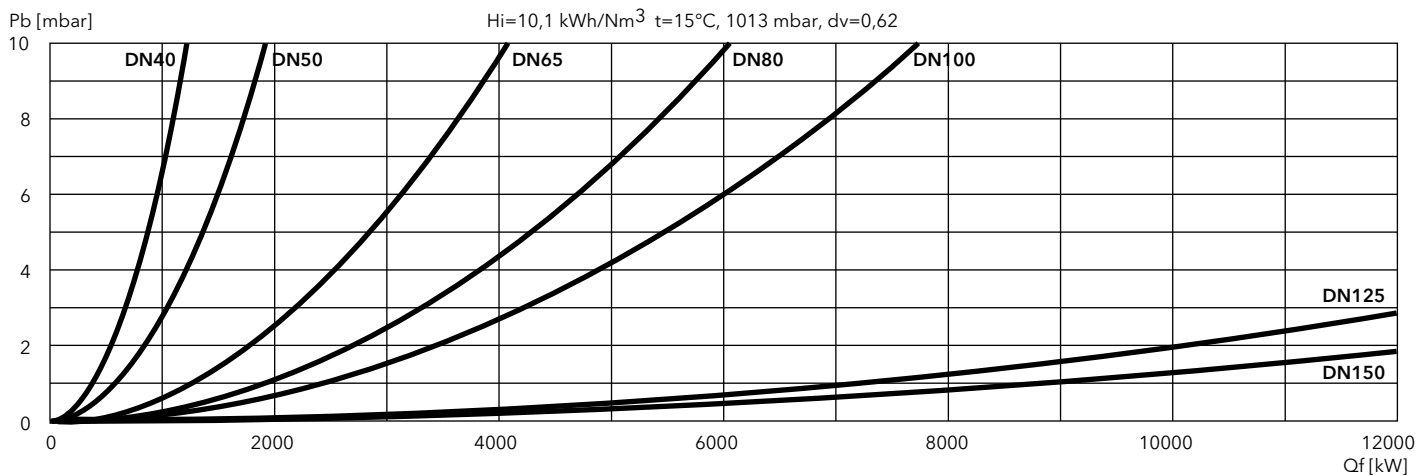

EKEVO 6 GL-E, EKEVO 7 GL-E

250 ... 4740 kW

2 stage progressive/modulating electronic in gas and in light oil

- **Fuels:** natural gas, Hi = 6,99 ... 11,39 kWh/Nm³;
light oil, viscosity 6 mm²/s at 20°C, Hi = 11,86 kWh/kg
- **Emission class:** Low NOx class 2 (≤120 mg/kWh) according to EN676 in gas
Low NOx class 2 (≤185 mg/kWh) according to EN267 in light oil
- **Protection level:** IP 41



TECHNICAL DATA

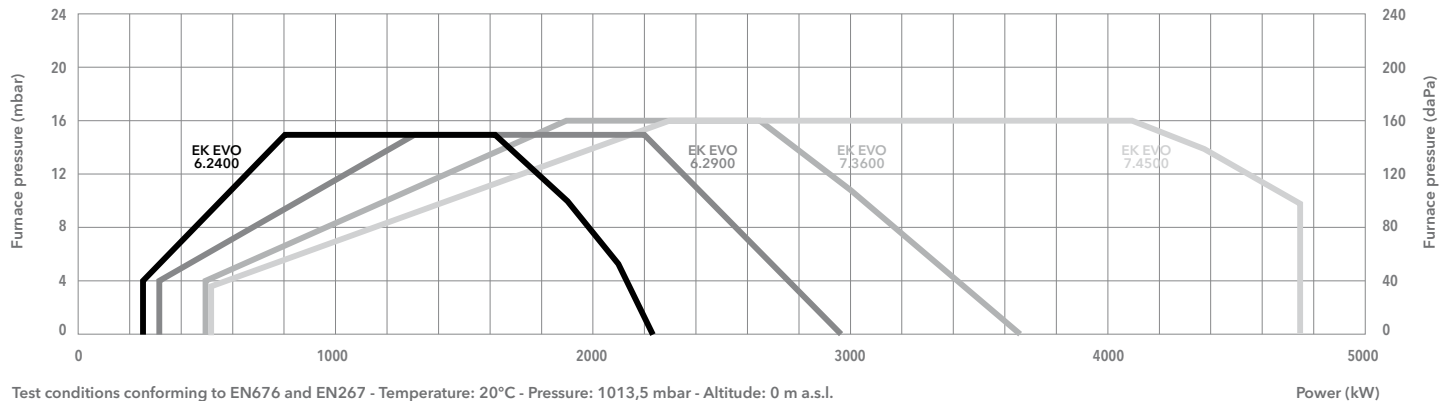

Test conditions conforming to EN676 and EN267 - Temperature: 20°C - Pressure: 1013,5 mbar - Altitude: 0 m a.s.l.

	EK EVO 6.2400 GL-E	EK EVO 6.2900 GL-E	EK EVO 7.3600 GL-E	EK EVO 7.4500 GL-E
Operating range gas	250 - 2230 kW	320 - 2970 kW	490 - 3650 kW	510 - 4740 kW
Operating range oil	510 - 2030 kW	650 - 2970 kW	900 - 3650 kW	1300 - 4740 kW
Gas pressure	50 - 500 mbar (50 - 360 mbar for d452 and d453)		50 - 500 mbar (50 - 360 mbar for d452 and d453)	
Gas connection	DN65	DN65	DN65	DN65
Control box / flame detector	BT300 / QRA2	BT300 / QRA2	BT300 / QRA2	BT300 / QRA2
Auxiliary voltage	1NPE AC 230 V - 50 Hz TN-S	1NPE AC 230 V - 50 Hz TN-S	1NPE AC 230 V - 50 Hz TN-S	1NPE AC 230 V - 50 Hz TN-S
Power supply	3PE AC 400 V - 50 Hz	3PE AC 400 V - 50 Hz	3PE AC 400 V - 50 Hz	3PE AC 400 V - 50 Hz
Fan motor	50 Hz - 3 kW	50 Hz - 4 kW	50 Hz - 5,5 kW	50 Hz - 7,5 kW
Acoustic level	<77 dB(A)	<77 dB(A)	<81 dB(A)	<82,5 dB(A)
CE certificate	0085CL0215	0085CL0215	0085CL0215	0085CL0215
Burner codes (body + head)	KN	3754276	3754277	3754279
	KM	3754280	3754281	3754283
	KL	3754284	3754285	3754287

GAS TRAINS

DUNGS

Model	Code
GT-d452-1"1/2 (*)	3750510
GT-d453-2" (*)	3750511
GT-d454-65	3750512
GT-d455-80	3750513
GT-d456-100	3750514

*: integrated filter

SIEMENS

Model	Code
GT-s451-1"1/2	3750525
GT-s452-2"	3750526
GT-s453-65	3750527
GT-s454-80	3750528
GT-s455-100	3750529
GT-s456-125	3750530

FILTERS

Model	Code
FG-Rp1"1/2	3757199
FG-Rp2"	3757200
FG-DN65	3757198
FG-DN80	3757201
FG-DN100	3757195
FG-DN125	3757209

Pressure drops graphs: see following pages
Dimensions of gas trains and gas filters: see pag. 206



DIMENSIONS (mm)

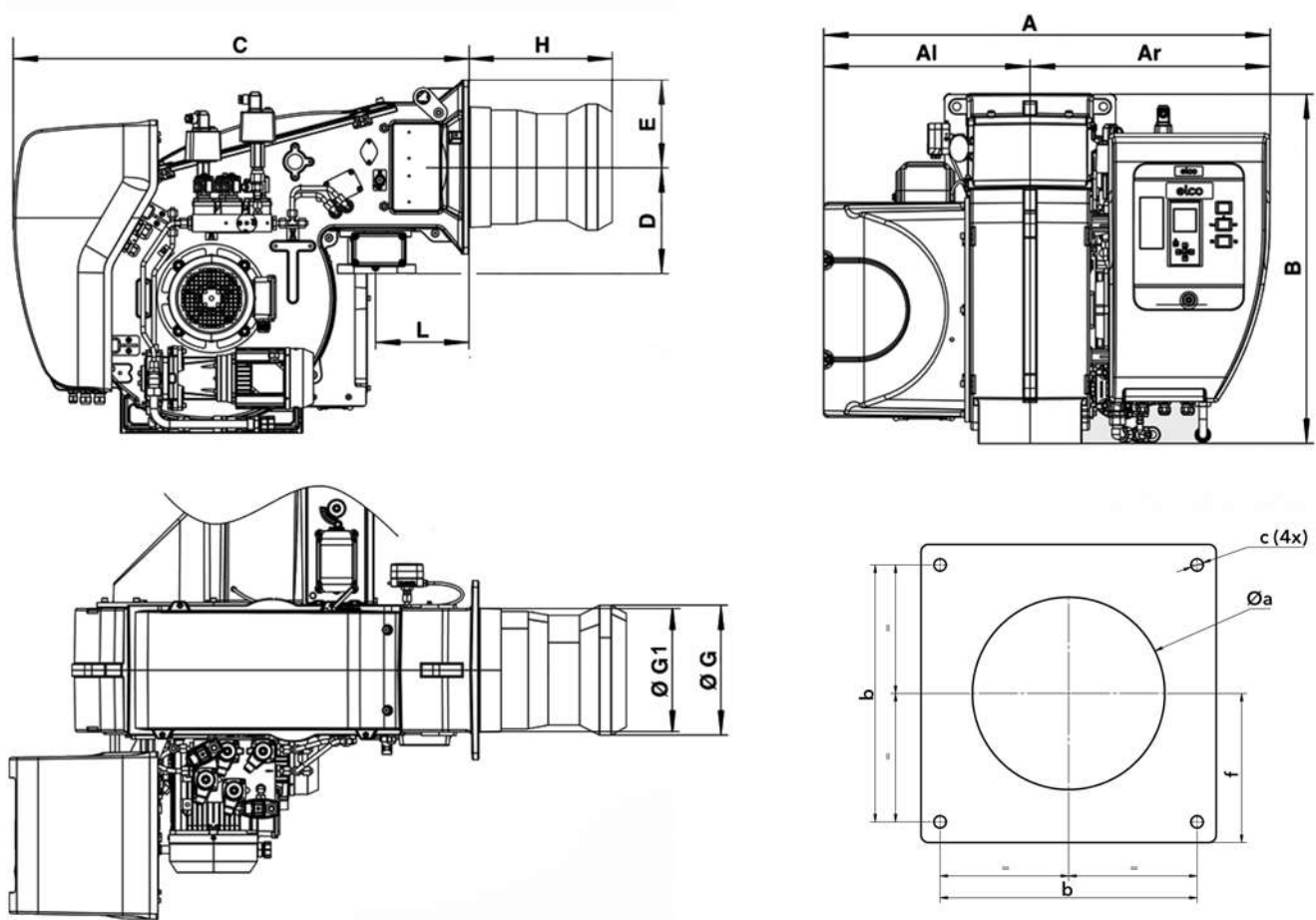

Model	A	Al	Ar	B	C	D	E	ØG	ØG1	H			L	Øa	b	c	f
										KN	KM	KL					
EK EVO 6.2400	1035	479	556	812	1048	245	200	290	262,5	330	450	570	215	300-340	340	M16	200
EK EVO 6.2900	1035	479	556	812	1048	245	200	310	262,5	330	450	570	215	320-340	340	M16	200
EK EVO 7.3600	1097	510	587	949	1122	275	235	340	281	375	505	635	225	350-400	400	M16	235
EK EVO 7.4500	1097	510	587	949	1122	275	235	370	308	375	505	635	225	380-400	400	M16	235

PACKAGING

The burner is delivered on a pallet in 2 packages containing:

- burner body with mounted combustion head, boiler fixing accessories and technical documentation;
- gas train and filter.

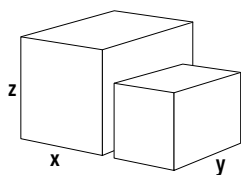

Models	Dimensions (mm)			Gross weight (kg)	
	X	Y	Z		
EK EVO 6.2400 GL-E	KN	2070	1420	990	188
	KM	2070	1420	990	190
	KL	2070	1420	990	192
EK EVO 6.2900 GL-E	KN	2070	1420	990	194
	KM	2070	1420	990	196
	KL	2070	1420	990	198
EK EVO 7.3600 GL-E	KN	2070	1420	1130	237
	KM	2070	1420	1130	239
	KL	2070	1420	1130	241
EK EVO 7.4500 GL-E	KN	2070	1420	1130	243
	KM	2070	1420	1130	245
	KL	2070	1420	1130	247

PRESSURE LOSSES (BURNER HEAD + GAS TRAIN)

EK EVO 6.2400 GL-E

DUNGS

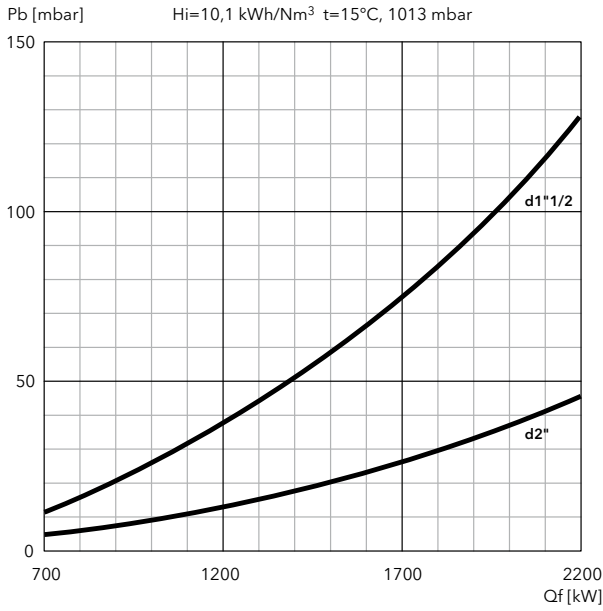

SIEMENS

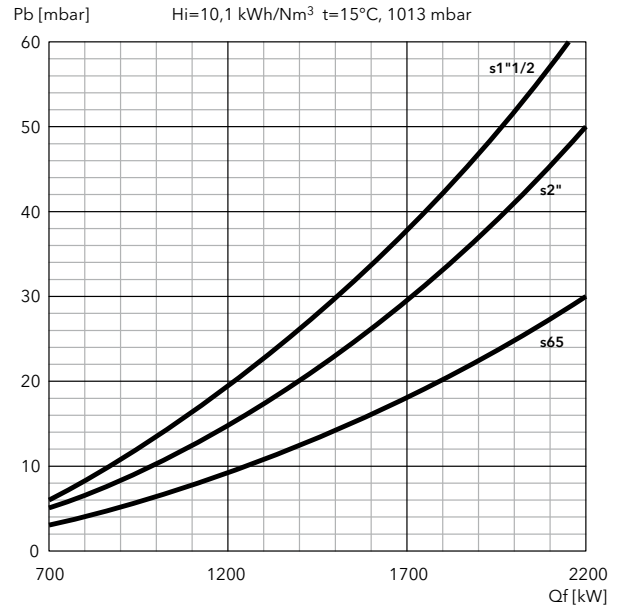

EK EVO 6.2900 GL-E

DUNGS

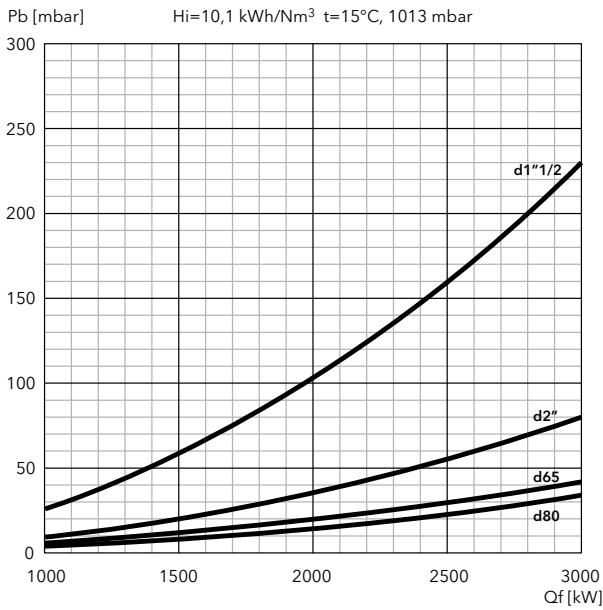

SIEMENS

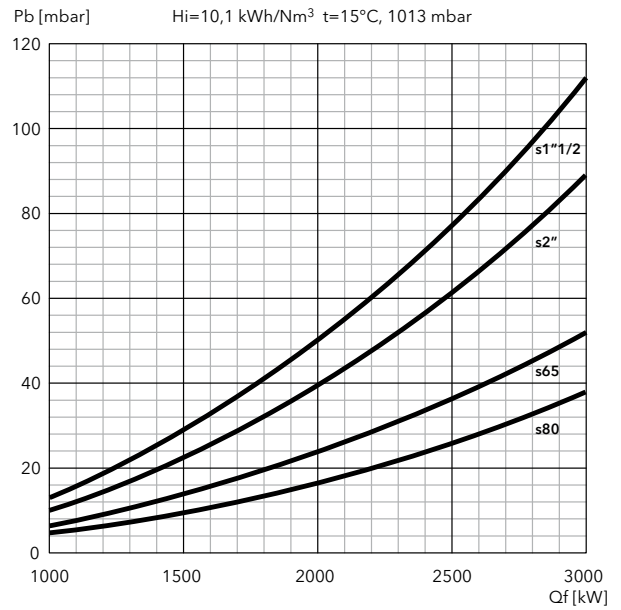

FILTERS

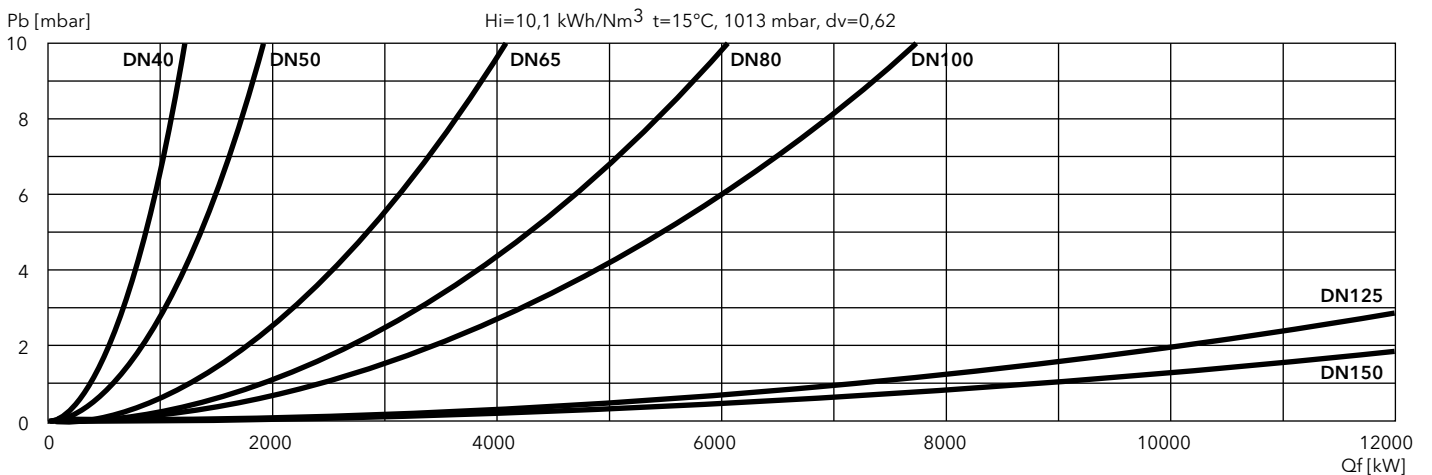

PRESSURE LOSSES (BURNER HEAD + GAS TRAIN)

EK EVO 7.3600 GL-E

DUNGS

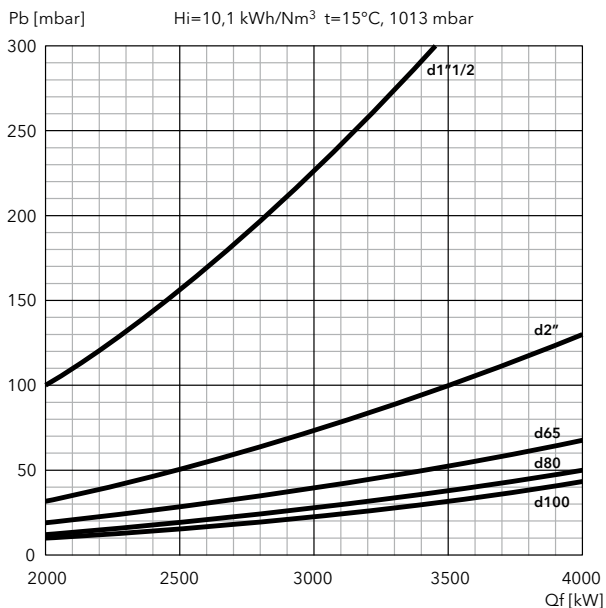

SIEMENS

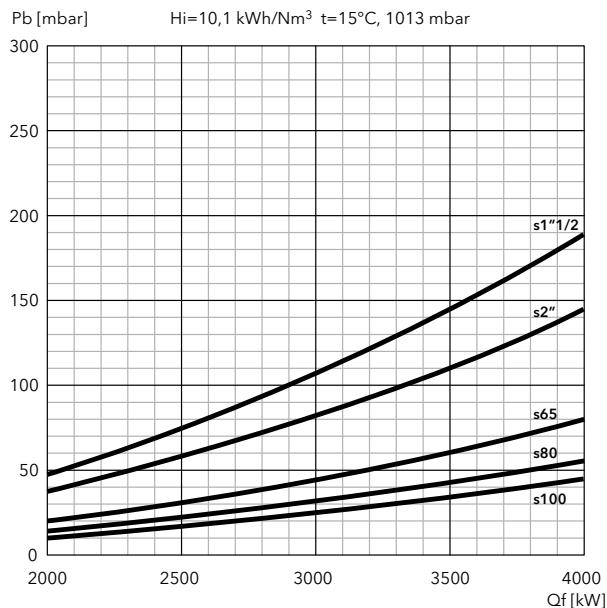

EK EVO 7.4500 GL-E

DUNGS

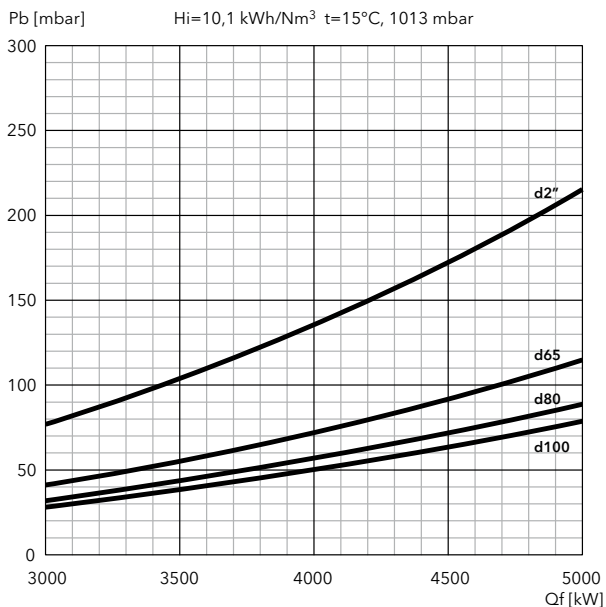

SIEMENS

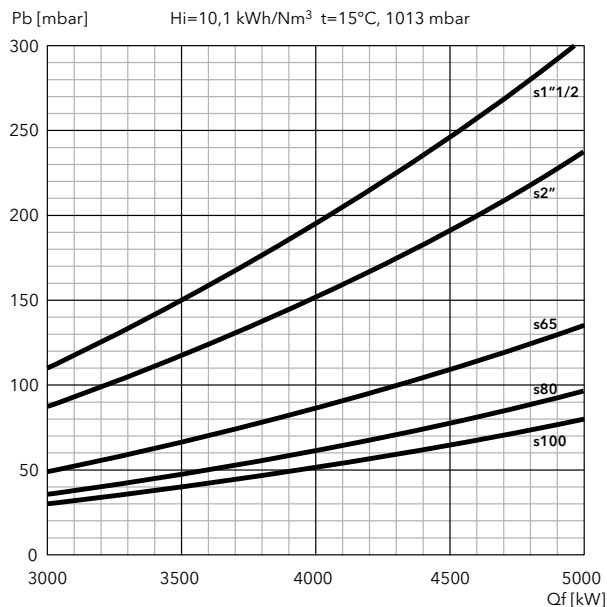

FILTERS

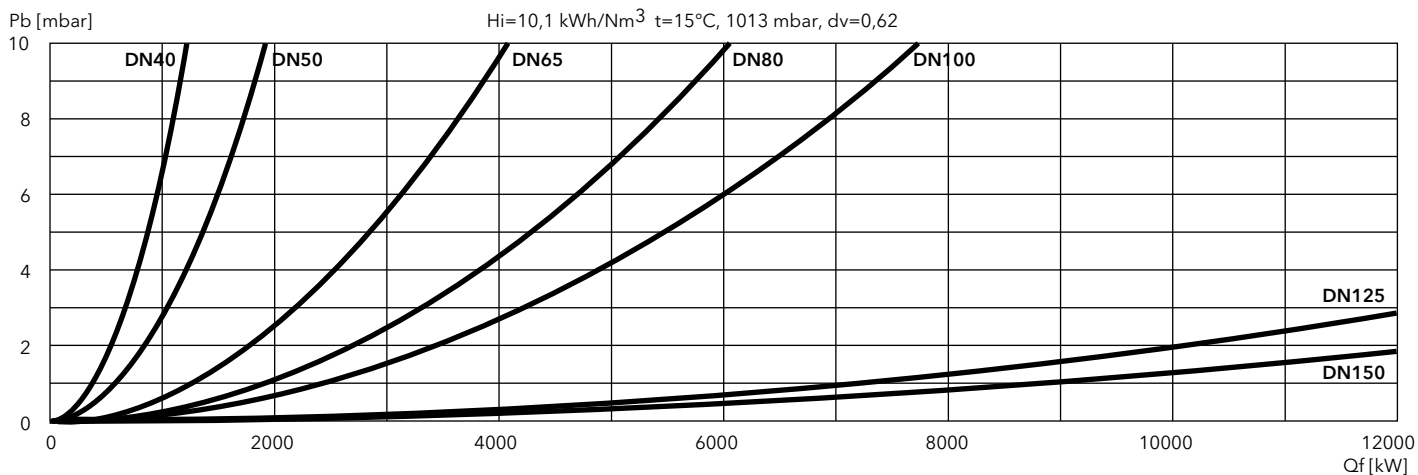

EKEVO 8 GL-E, EKEVO 9 GL-E

790 ... 10620 kW

2 stage progressive/modulating electronic in gas and in light oil

- **Fuels:** natural gas, Hi = 6,99 ... 11,39 kWh/Nm³;
light oil, viscosity 6 mm²/s at 20°C, Hi = 11,86 kWh/kg
- **Emission class:** Low NOx class 2 (≤120 mg/kWh) according to EN676 in gas
Low NOx class 2 (≤185 mg/kWh) according to EN267 in light oil
- **Protection level:** IP 41

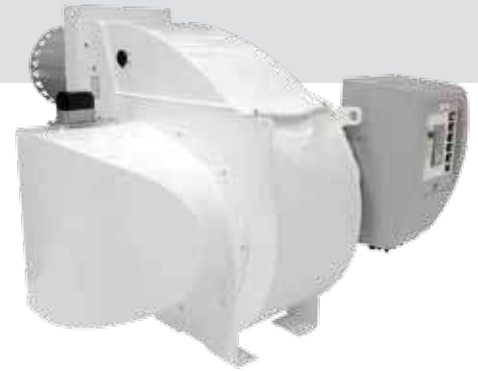
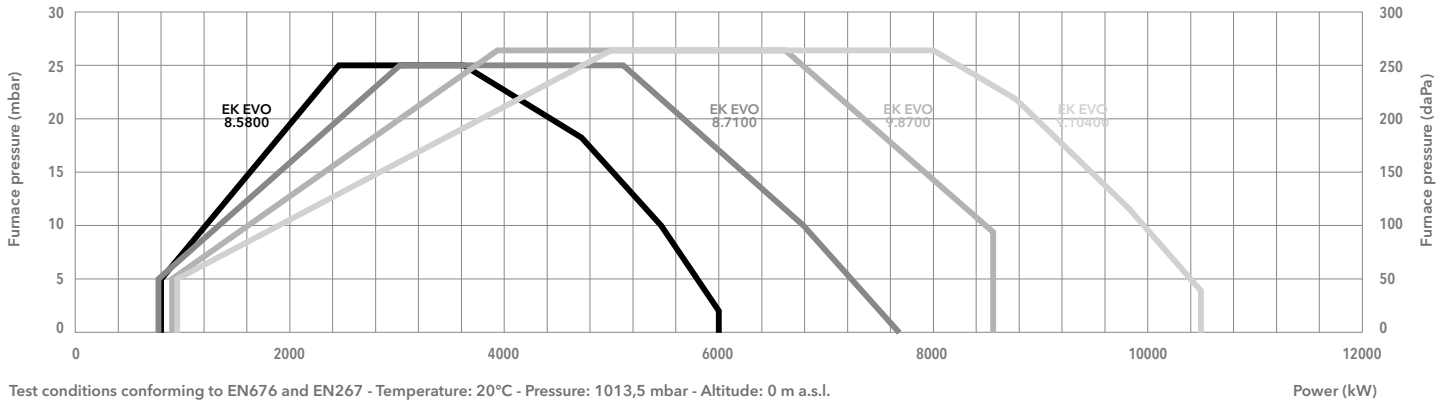
TECHNICAL DATA

	EK EVO 8.5800 GL-E	EK EVO 8.7100 GL-E	EK EVO 9.8700 GL-E	EK EVO 9.10400 GL-E
Operating range gas	800 - 6000 kW	790 - 7700 kW	880 - 8530 kW	910 - 10620 kW
Operating range oil	1210 - 6000 kW	1450 - 7700 kW	2400 - 8530 kW	2820 - 10620 kW
Gas pressure	100 - 500 mbar (100 - 360 mbar for d457)		100 - 500 mbar (100 - 360 mbar for d457)	
Gas connection	DN100	DN100	DN100	DN100
Control box / flame detector	BT300 / QRA2	BT300 / QRA2	BT300 / QRA2	BT300 / QRA2
Auxiliary voltage	1NPE AC 230 V - 50 Hz TN-S	1NPE AC 230 V - 50 Hz TN-S	1NPE AC 230 V - 50 Hz TN-S	1NPE AC 230 V - 50 Hz TN-S
Power supply	3PE AC 400 V - 50 Hz	3PE AC 400 V - 50 Hz	3PE AC 400 V - 50 Hz	3PE AC 400 V - 50 Hz
Fan motor	50 Hz - 11 kW	50 Hz - 15 kW	50 Hz - 18,5 kW	50 Hz - 22 kW
Acoustic level	<80,5 dB(A)	<82,6 dB(A)	<85,5 dB(A)	<86,2 dB(A)
CE certificate	0085CL0215	0085CL0215	0085CL0215	0085CL0215
Burner codes (body + head)	KN	3754601	3754602	3754603
	KM	3754605	3754606	3754607
	KL	3754609	3754610	3754611

GAS TRAINS
DUNGS

Model	Code
GT-d457-2" (*)	3750515
GT-d458-65	3750516
GT-d459-80	3750517
GT-d460-100	3750518

*: integrated filter

SIEMENS

Model	Code
GT-s457-2"	3750537
GT-s458-65	3750538
GT-s459-80	3750539
GT-s460-100	3750540
GT-s461-125	3750541

FILTERS

Model	Code
FG-Rp2"	3757200
FG-DN65	3757198
FG-DN80	3757201
FG-DN100	3757195
FG-DN125	3757209

Pressure drops graphs: see following pages
Dimensions of gas trains and gas filters: see pag. 207



DIMENSIONS (mm)

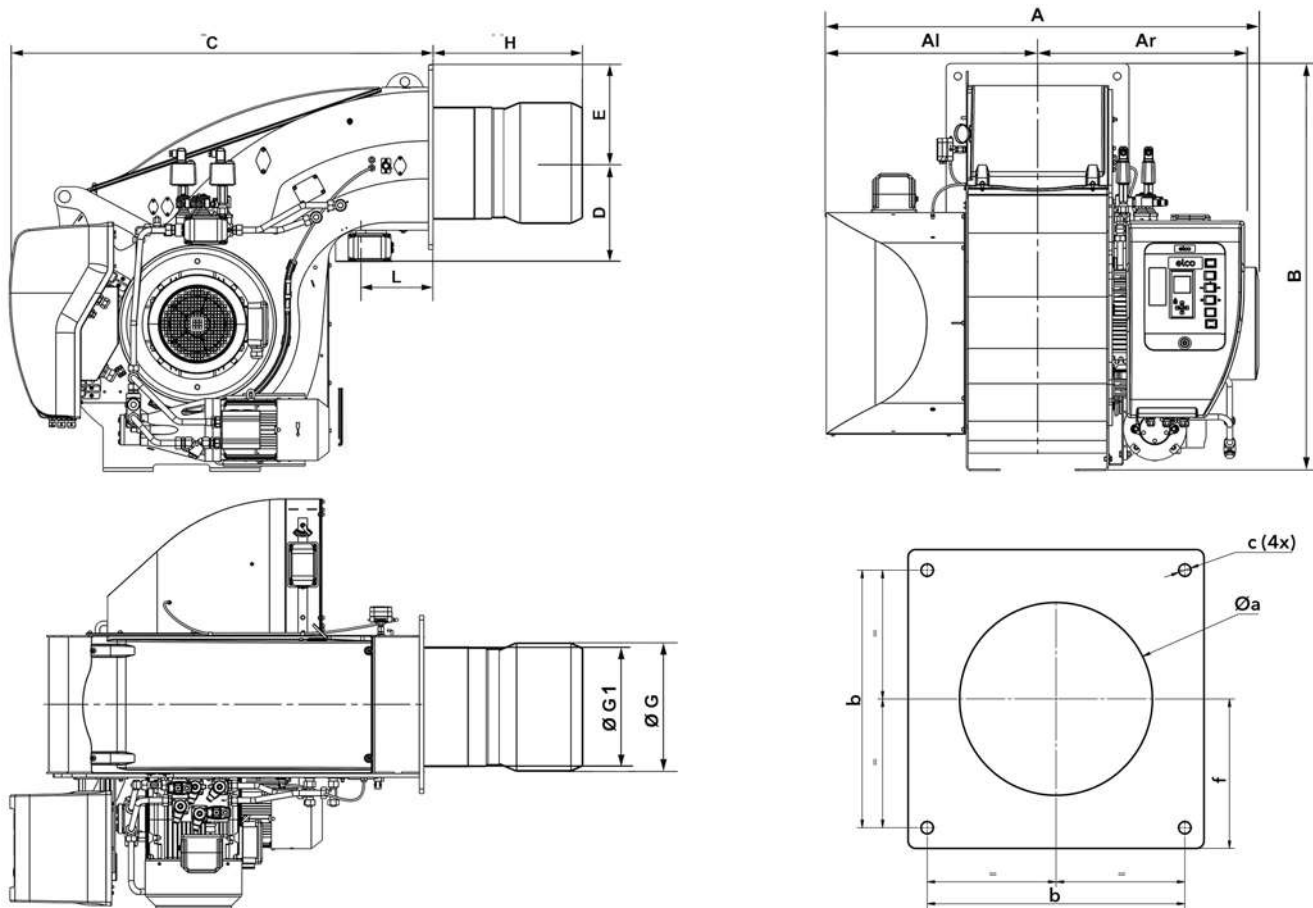

Model	A	Al	Ar	B	C	D	E	ØG	ØG1	H			L	Øa	b	c	f
										KN	KM	KL					
EKEVO 8.5800	1325	670	655	1231	1351	391	307	400	369	562	702	842	230	430-480	505	M20	293
EKEVO 8.7100	1325	670	655	1231	1351	391	307	415	369	583	723	863	230	445-480	505	M20	293
EKEVO 9.8700	1336	670	666	1291	1348	332	288	431,5	438,5	355	505	655	230	445-480	505	M20	293
EKEVO 9.10400	1400	670	731	1291	1348	332	293	431,5	438,5	355	505	655	230	445-480	505	M20	293

PACKAGING

The burner is delivered on a pallet in 2 packages containing:

- burner body with mounted combustion head, boiler fixing accessories and technical documentation;
- gas train and filter.

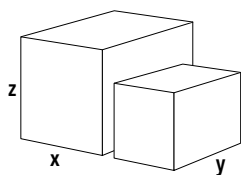

Models		Dimensions (mm)			Gross weight (kg)
		X	Y	Z	
EKEVO 8.5800 GL-E	KN	2300	1500	1396	615
	KM	2300	1500	1396	621
	KL	2300	1500	1396	632
EKEVO 8.7100 GL-E	KN	2300	1500	1396	631
	KL	2300	1500	1396	648
EKEVO 9.8700 GL-E	KN	2300	1500	1396	658
	KM	2300	1500	1396	666
	KL	2300	1500	1396	673
EKEVO 9.10400 GL-E	KN	2300	1500	1461	680
	KM	2300	1500	1461	687
	KL	2300	1500	1461	699

PRESSURE LOSSES (BURNER HEAD + GAS TRAIN)

EK EVO 8.5800 GL-E

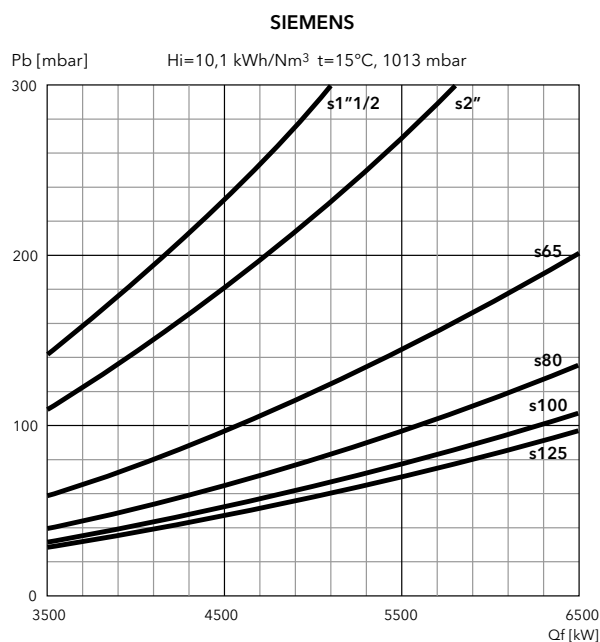
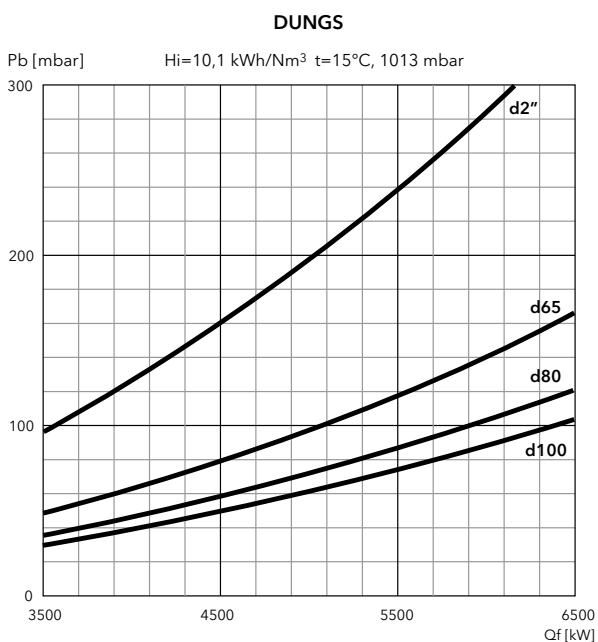

EK EVO 8.7100 GL-E

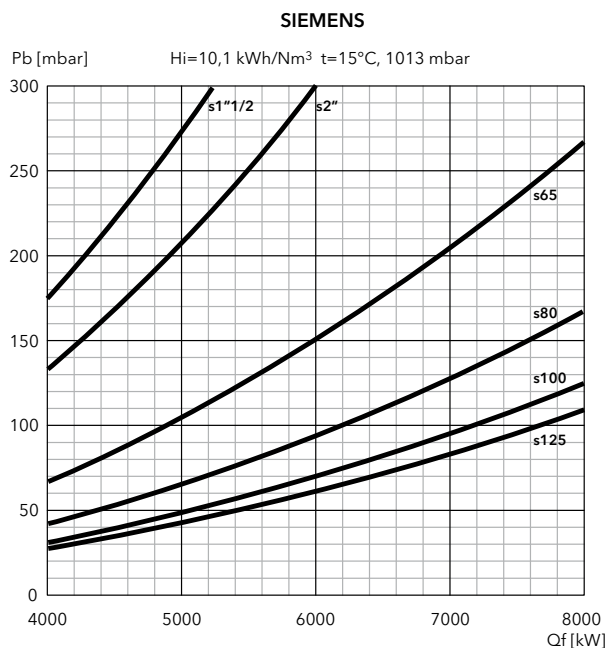
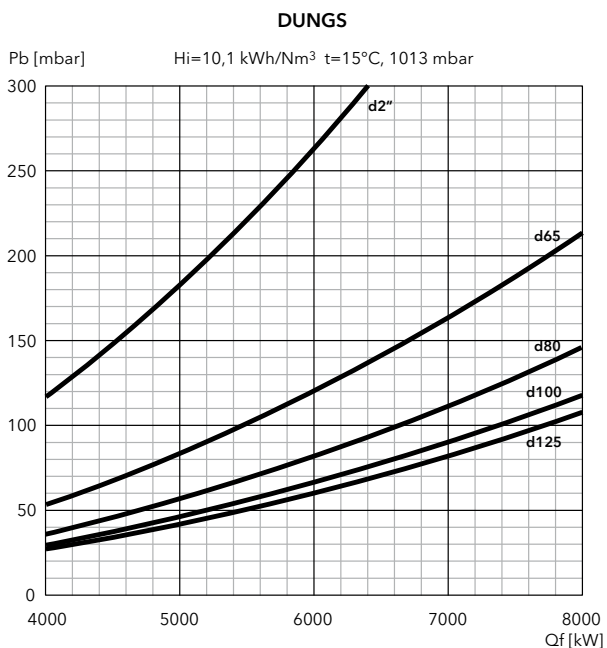

FILTERS

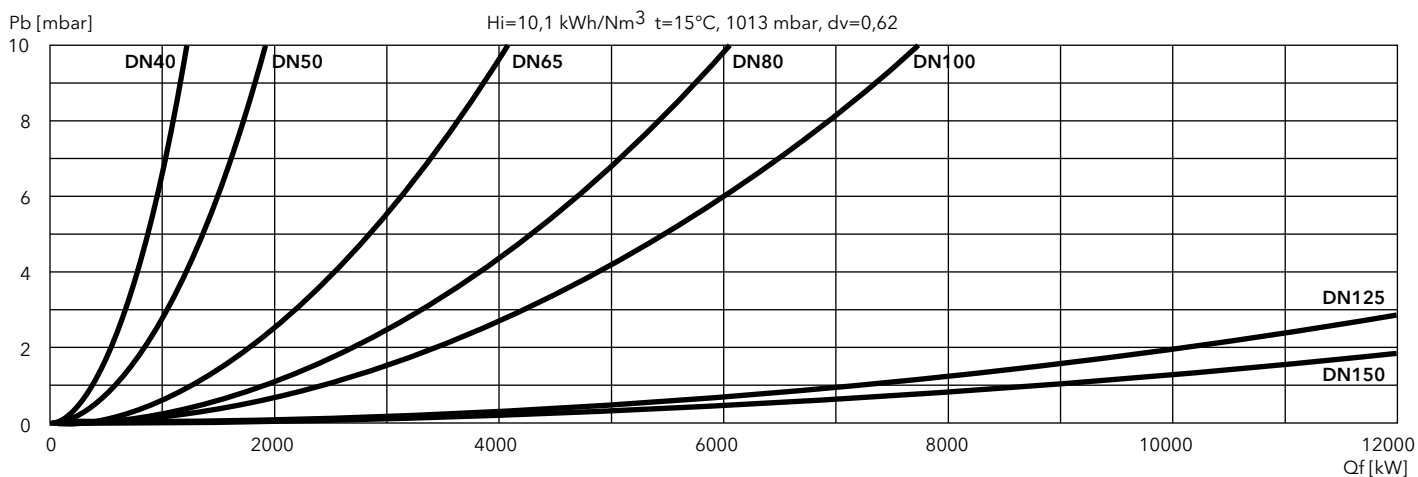

PRESSURE LOSSES (BURNER HEAD + GAS TRAIN)

EK EVO 9.8700 GL-E

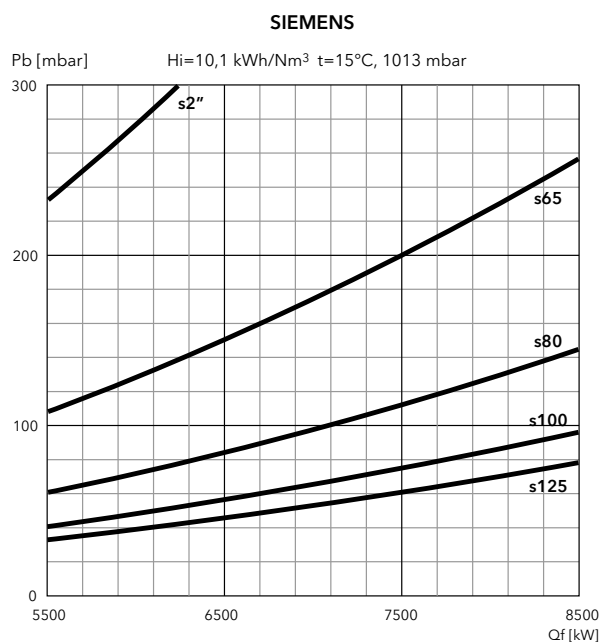
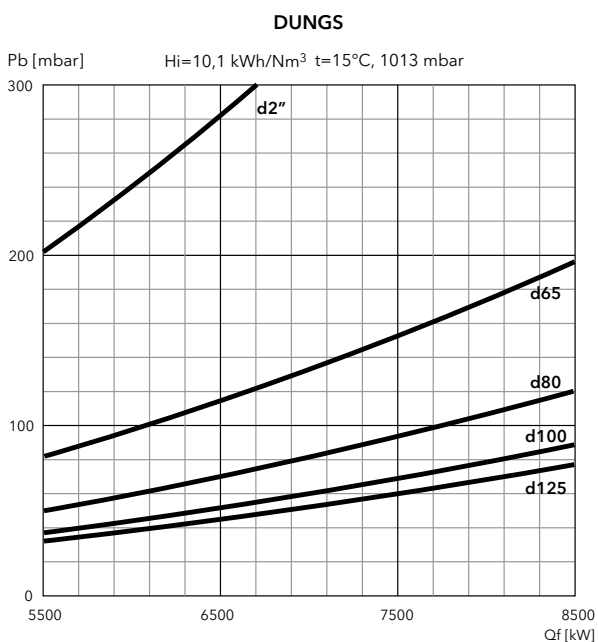

EK EVO 9.10400 GL-E

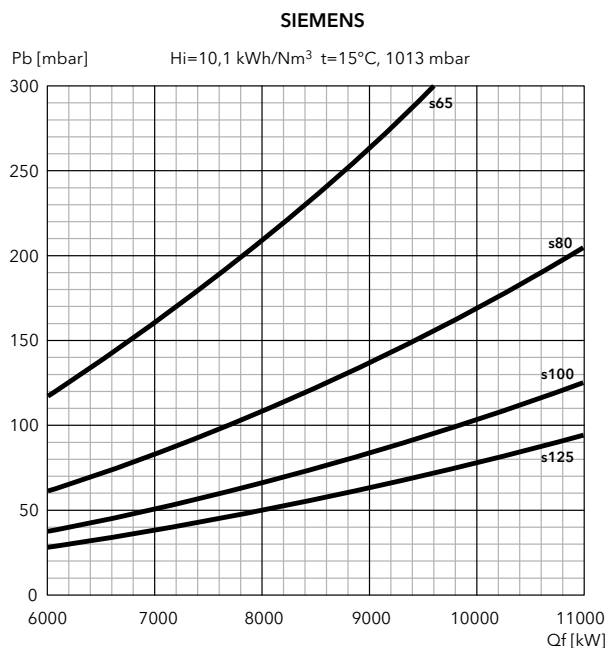
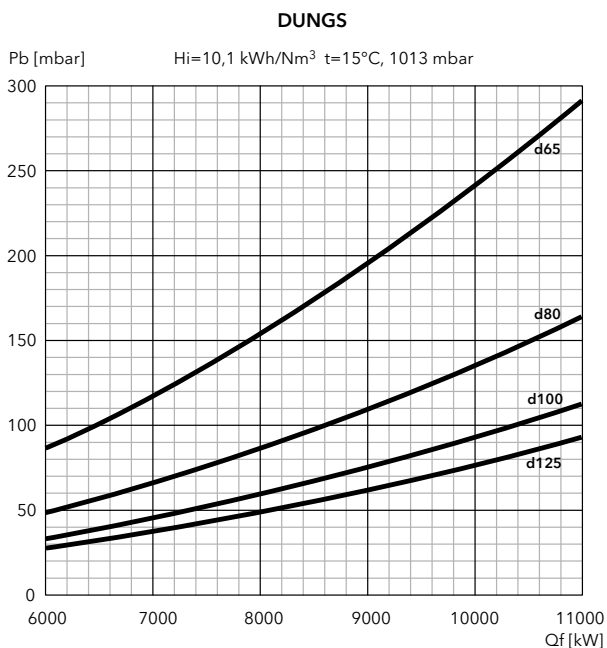

FILTERS

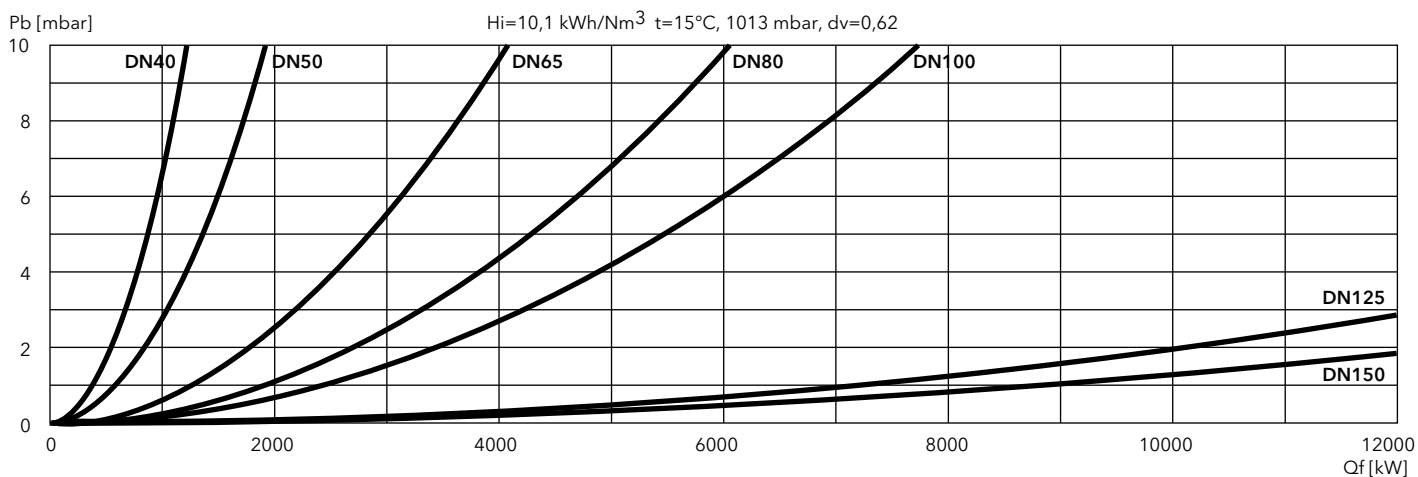

EKEVO 6 GL-EF3, EKEVO 7 GL-EF3

280 ... 4500 kW

2 stage progressive/modulating electronic in gas and in light oil (Low NOx class 3)

- **Fuels:** natural gas, Hi = 6,99 ... 11,39 kWh/Nm³;
light oil, viscosity 6 mm²/s at 20°C, Hi = 11,86 kWh/kg
- **Emission class:** Low NOx class 3 (≤80 mg/kWh) according to EN676 in gas
Low NOx class 3 (≤120 mg/kWh) according to EN267 in light oil
- **Protection level:** IP 41

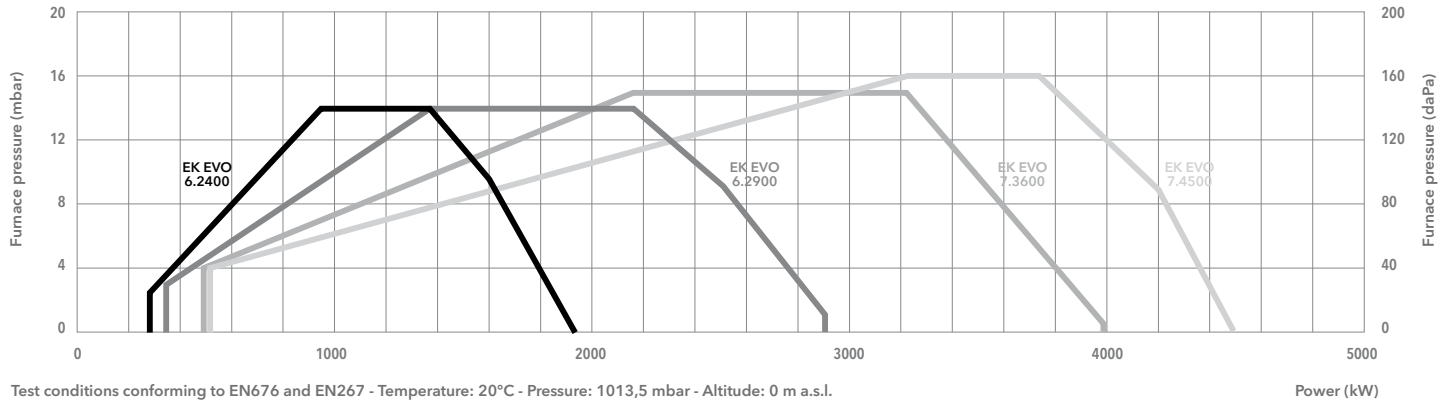
TECHNICAL DATA

Test conditions conforming to EN676 and EN267 - Temperature: 20°C - Pressure: 1013,5 mbar - Altitude: 0 m a.s.l.

	EK EVO 6.2400 GL-EF3	EK EVO 6.2900 GL-EF3	EK EVO 7.3600 GL-EF3	EK EVO 7.4500 GL-EF3
Operating range gas	280 - 1920 kW	340 - 2890 kW	470 - 3980 kW	510 - 4500 kW
Operating range oil	360 - 1920 kW	480 - 2890 kW	680 - 3980 kW	740 - 4500 kW
Gas pressure	50 - 500 mbar (50 - 360 mbar for d452 and d453)			
Gas connection	DN65	DN65	DN65	DN65
Control box / flame detector	BT300 / FFS08	BT300 / FFS08	BT300 / FFS08	BT300 / FFS08
Auxiliary voltage	1NPE AC 230 V - 50 Hz TN-S	1NPE AC 230 V - 50 Hz TN-S	1NPE AC 230 V - 50 Hz TN-S	1NPE AC 230 V - 50 Hz TN-S
Power supply	3PE AC 400 V - 50 Hz	3PE AC 400 V - 50 Hz	3PE AC 400 V - 50 Hz	3PE AC 400 V - 50 Hz
Fan motor	50 Hz - 3 kW	50 Hz - 4 kW	50 Hz - 7,5 kW	50 Hz - 7,5 kW
Acoustic level	<76 dB(A)	<77 dB(A)	<83 dB(A)	<81 dB(A)
CE certificate	0085CL0215	0085CL0215	0085CL0215	0085CL0215
Burner codes (body + head)	KN	3754521	3754522	3754523
	KM	3754525	3754526	3754527
	KL	3754529	3754530	3754531

GAS TRAINS
DUNGS

Model	Code
GT-d452-1"1/2 (*)	3750510
GT-d453-2" (*)	3750511
GT-d454-65	3750512
GT-d455-80	3750513
GT-d456-100	3750514

*: integrated filter

SIEMENS

Model	Code
GT-s451-1"1/2	3750525
GT-s452-2"	3750526
GT-s453-65	3750527
GT-s454-80	3750528
GT-s455-100	3750529
GT-s456-125	3750530

FILTERS

Model	Code
FG-Rp1"1/2	3757199
FG-Rp2"	3757200
FG-DN65	3757198
FG-DN80	3757201
FG-DN100	3757195
FG-DN125	3757209

 **Pressure drops graphs:** see following pages
Dimensions of gas trains and gas filters: see pag. 206



DIMENSIONS (mm)

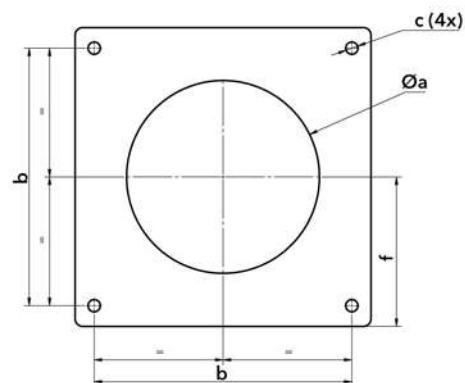
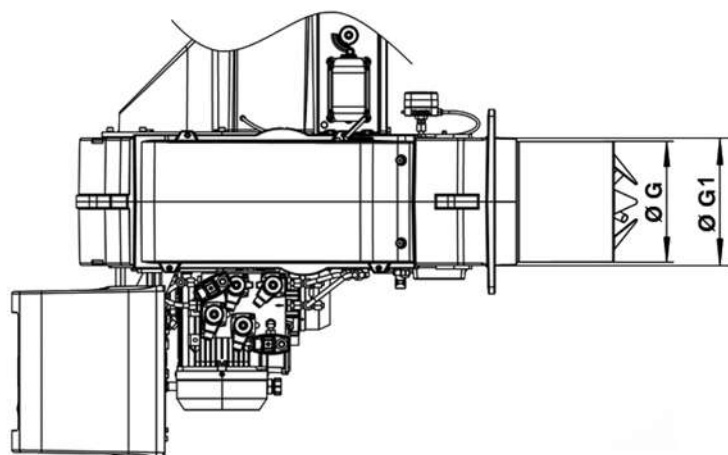
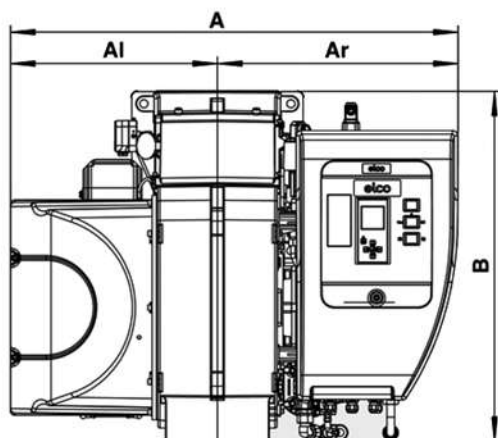
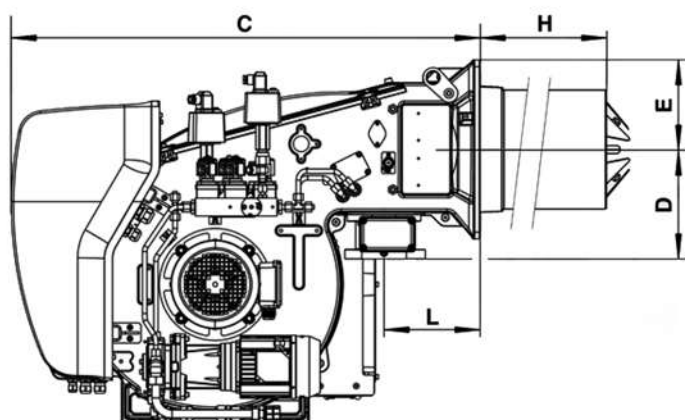

Model	A	Al	Ar	B	C	D	E	ØG	ØG1	H			L	Øa	b	c	f
										KN	KM	KL					
EKEVO 6.2400	1035	479	556	812	1046	245	200	227	263,5	400	520	640	212	300-340	340	M16	200
EKEVO 6.2900	1035	479	556	812	1048	245	200	262,5	263,5	400	520	640	215	300-340	340	M16	200
EKEVO 7.3600	1097	510	587	941	1122	276	235	323,5	325	420	550	680	225	360-400	400	M16	235
EKEVO 7.4500	1097	510	587	941	1122	276	235	323,5	325	420	550	680	225	360-400	400	M16	235

PACKAGING

The burner is delivered on a pallet in 2 packages containing:

- burner body with mounted combustion head, boiler fixing accessories and technical documentation;
- gas train and filter.

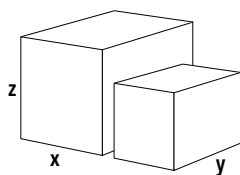

Models		Dimensions (mm)			Gross weight (kg)
		X	Y	Z	
EKEVO 6.2400 GL-EF3	KN	2070	1420	990	188
	KM	2070	1420	990	190
	KL	2070	1420	990	192
EKEVO 6.2900 GL-EF3	KN	2070	1420	990	194
	KM	2070	1420	990	196
	KL	2070	1420	990	198
EKEVO 7.3600 GL-EF3	KN	2070	1420	1130	243
	KM	2070	1420	1130	245
	KL	2070	1420	1130	247
EKEVO 7.4500 GL-EF3	KN	2070	1420	1130	243
	KM	2070	1420	1130	245
	KL	2070	1420	1130	247

PRESSURE LOSSES (BURNER HEAD + GAS TRAIN)

EK EVO 6.2400 GL-EF3

DUNGS

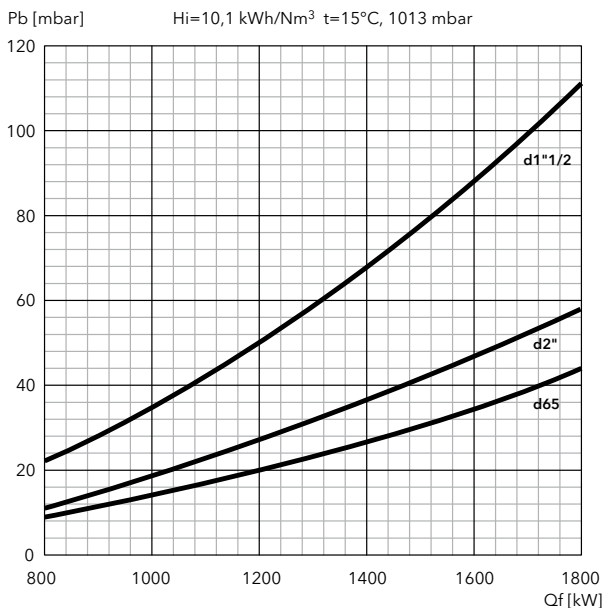

SIEMENS

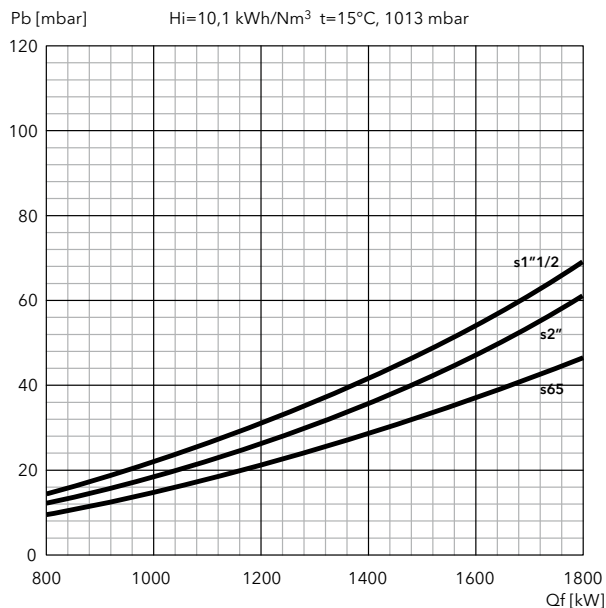

EK EVO 6.2900 GL-EF3

DUNGS

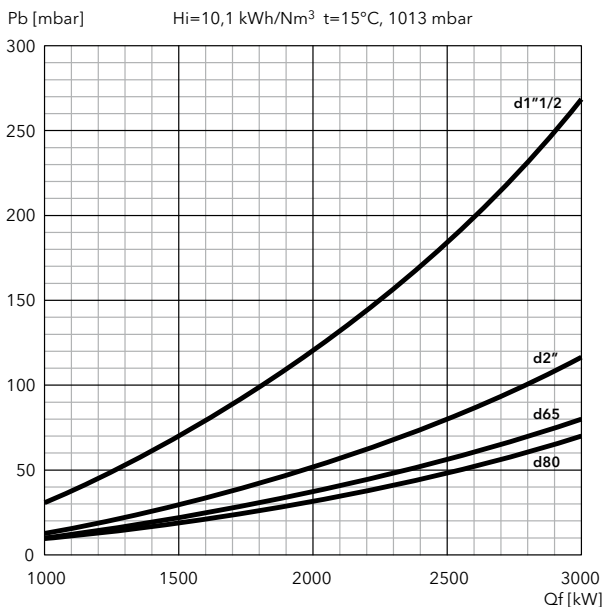

SIEMENS

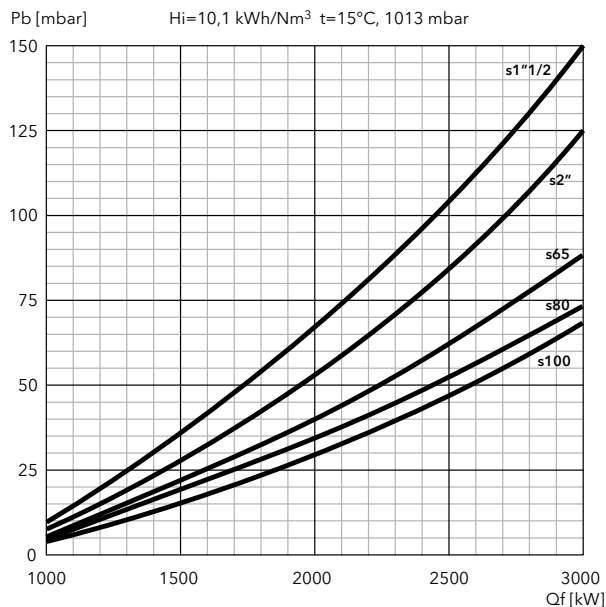

FILTERS

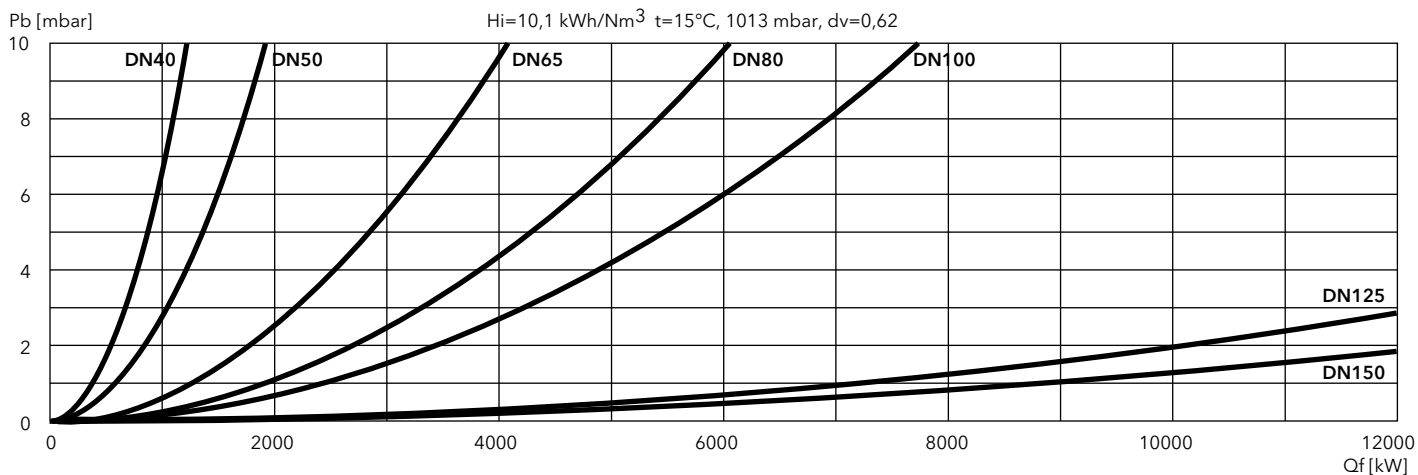

PRESSURE LOSSES (BURNER HEAD + GAS TRAIN)

EK EVO 7.3600 GL-EF3

DUNGS

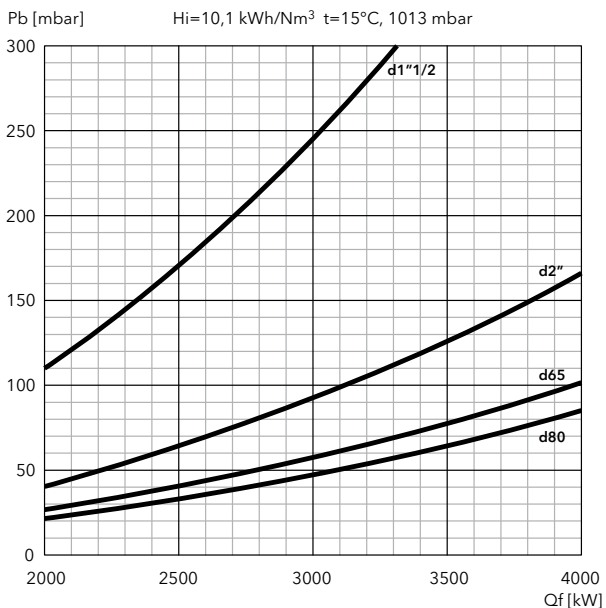

SIEMENS

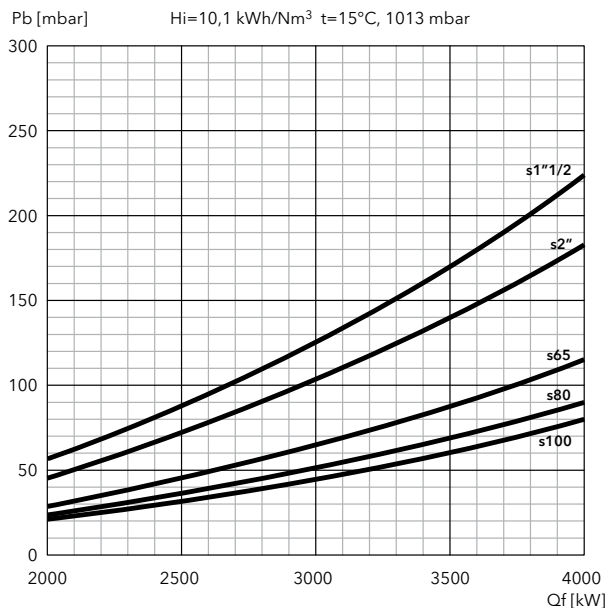

EK EVO 7.4500 GL-EF3

DUNGS

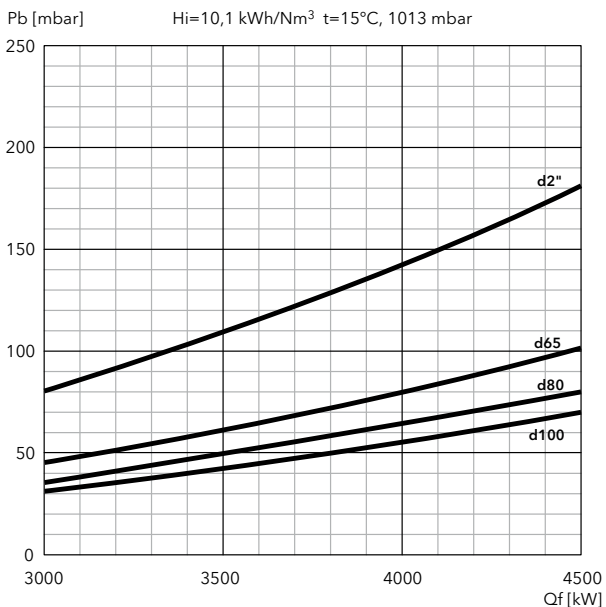

SIEMENS

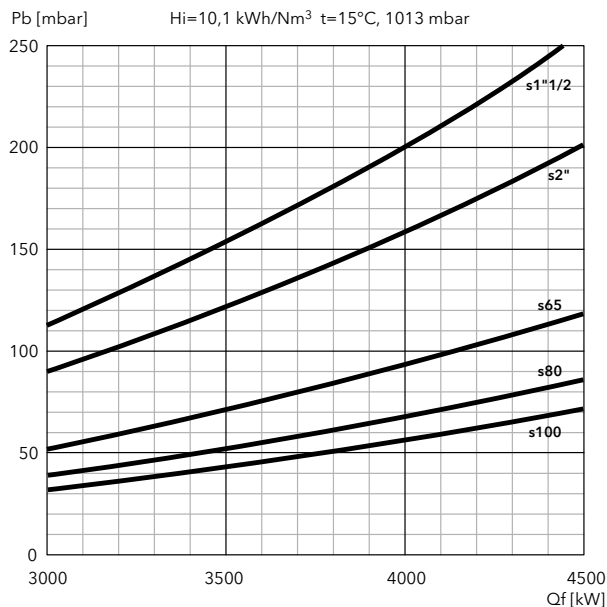

FILTERS

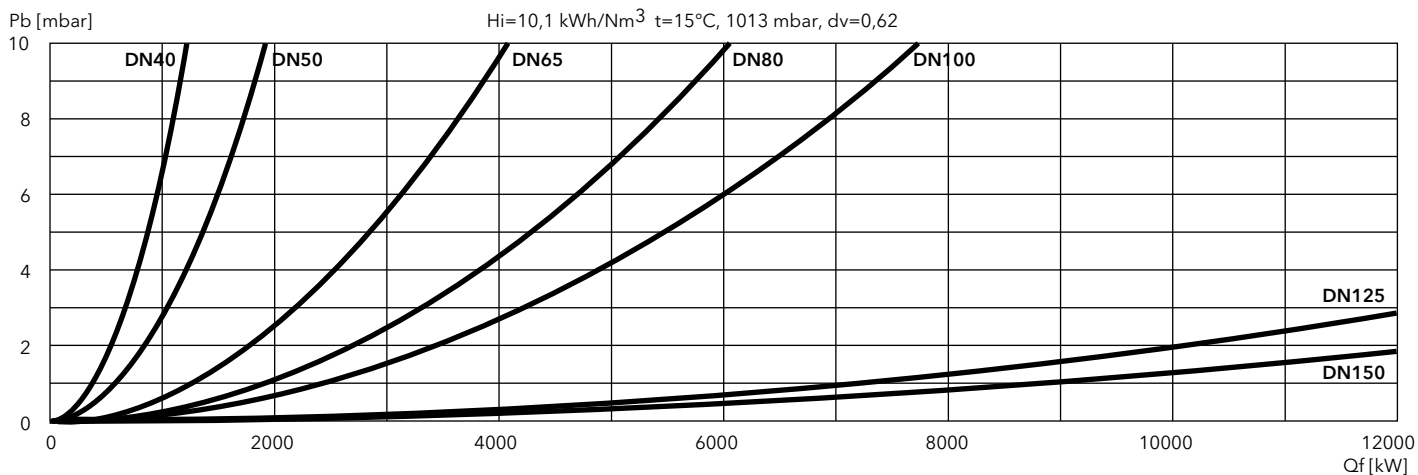

EKEVO 8 GL-EF3, EKEVO 9 GL-EF3

830 ... 6950 kW

2 stage progressive/modulating electronic in gas and in light oil (Low NOx class 3)

- **Fuels:** natural gas, Hi = 6,99 ... 11,39 kWh/Nm³;
light oil, viscosity 6 mm²/s at 20°C, Hi = 11,86 kWh/kg
- **Emission class:** Low NOx class 3 (≤80 mg/kWh) according to EN676 in gas
Low NOx class 3 (≤120 mg/kWh) according to EN267 in light oil
- **Protection level:** IP 41



TECHNICAL DATA

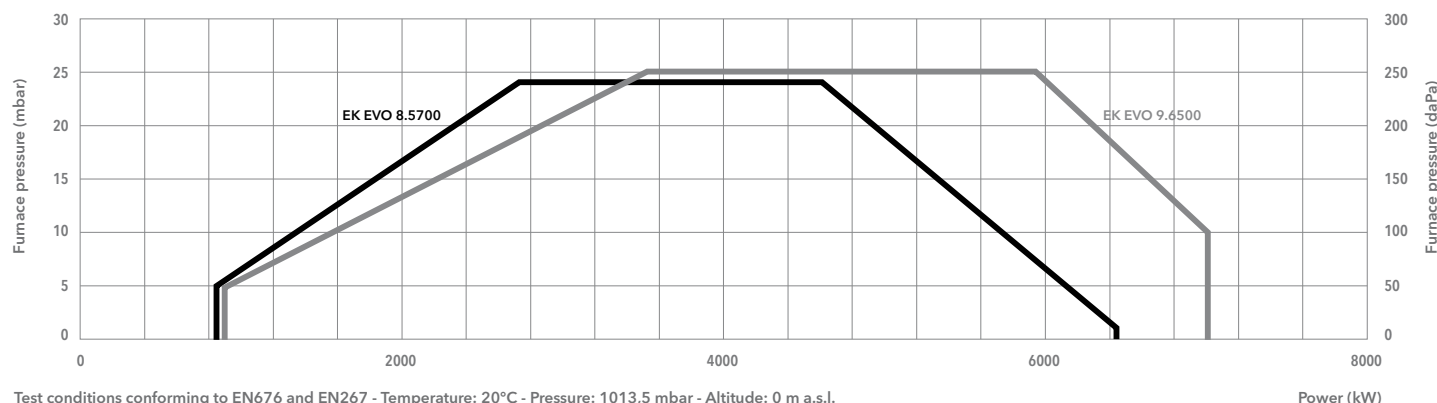

Test conditions conforming to EN676 and EN267 - Temperature: 20°C - Pressure: 1013,5 mbar - Altitude: 0 m a.s.l.

	EK EVO 8.5700 GL-EF3	EK EVO 9.6500 GL-EF3
Operating range gas	830 - 6450 kW	860 - 6950 kW
Operating range oil	1100 - 6450 kW	1100 - 6600 kW
Gas pressure	100 - 500 mbar (100 - 360 mbar for d457)	100 - 500 mbar (100 - 360 mbar for d457)
Gas connection	DN100	DN100
Control box / flame detector	BT300 / FFS08	BT300 / FFS08
Auxiliary voltage	1NPE AC 230 V - 50 Hz TN-S	1NPE AC 230 V - 50 Hz TN-S
Power supply	3PE AC 400 V - 50 Hz	3PE AC 400 V - 50 Hz
Fan motor	50 Hz - 15 kW	50 Hz - 22 kW
Acoustic level	<80,2 dB(A)	<82,9 dB(A)
CE certificate	0085CL0215	0085CL0215
Burner codes (body + head)	KN	3754825
	KM	3754829
	KL	3754833
		3754834

GAS TRAINS

DUNGS

Model	Code
GT-d457-2" (*)	3750515
GT-d458-65	3750516
GT-d459-80	3750517
GT-d460-100	3750518

SIEMENS

Model	Code
GT-s457-2"	3750537
GT-s458-65	3750538
GT-s459-80	3750539
GT-s460-100	3750540
GT-s461-125	3750541

FILTERS

Model	Code
FG-Rp2"	3757200
FG-DN65	3757198
FG-DN80	3757201
FG-DN100	3757195
FG-DN125	3757209

*: integrated filter

 **Pressure drops graphs:** see following pages
Dimensions of gas trains and gas filters: see pag. 207



DIMENSIONS (mm)

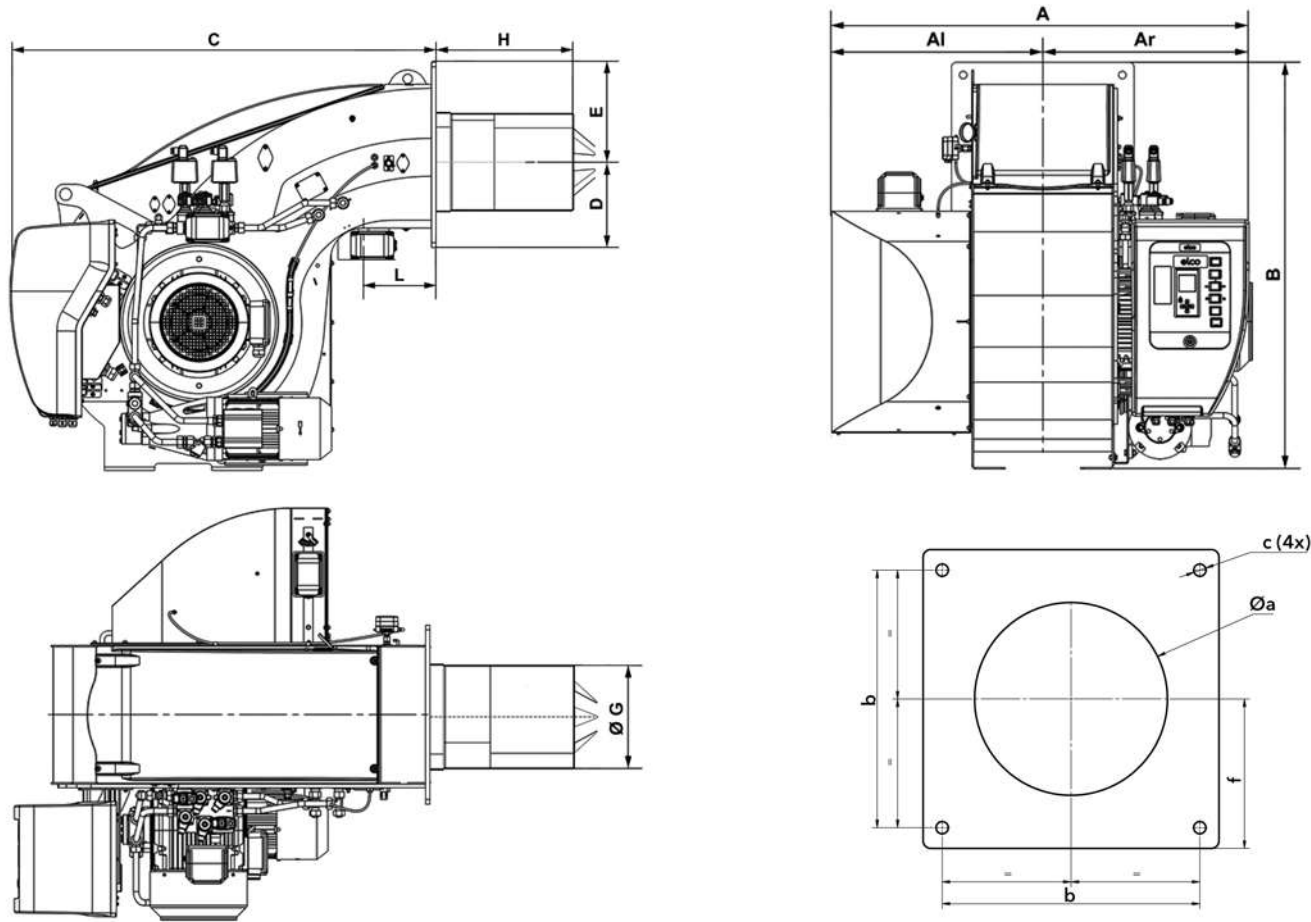

Model	A	Al	Ar	B	C	D	E	ØG	ØG1	H			L	Øa	b	c	f
										KN	KM	KL					
EKEVO 8.5700	1325	670	655	1231	1351	307	288	369	376	528	668	808	230	380-410	505	M20	293
EKEVO 9.6500	1400	670	730	1291	1348	332	293	369	438,5	543	693	843	230	445-480	505	M20	293

PACKAGING

The burner is delivered on a pallet in 2 packages containing:

- burner body with mounted combustion head, boiler fixing accessories and technical documentation;
- gas train and filter.

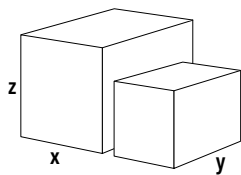

Models	Dimensions (mm)			Gross weight (kg)	
	X	Y	Z		
EK EVO 8.5700 GL-EF3	KN	2300	1500	1396	369
	KM	2300	1500	1396	369
	KL	2300	1500	1396	369
EK EVO 9.6500 GL-EF3	KN	2300	1500	1461	369
	KM	2300	1500	1461	369
	KL	2300	1500	1461	369

PRESSURE LOSSES (BURNER HEAD + GAS TRAIN)

EK EVO 8.5700 GL-EF3

DUNGS

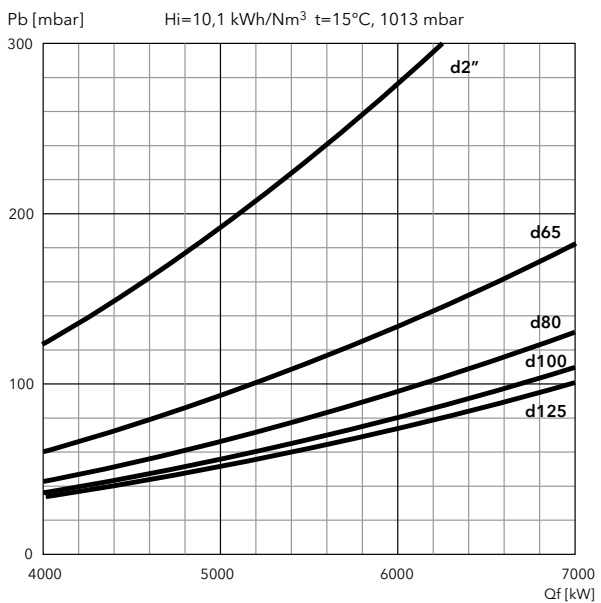

SIEMENS

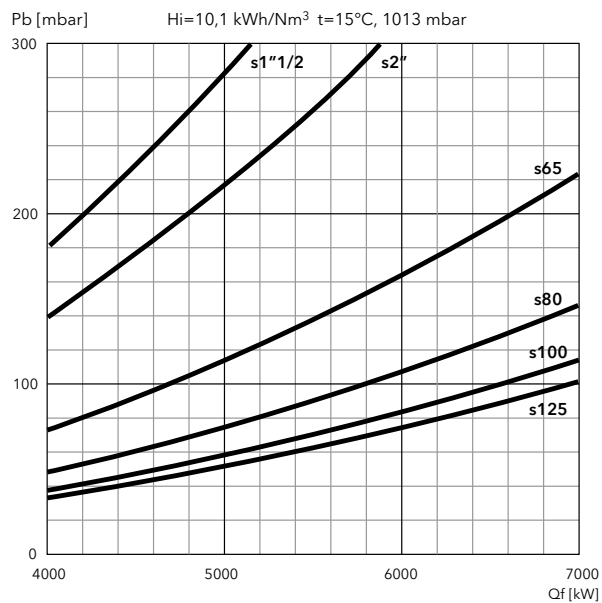

FILTERS

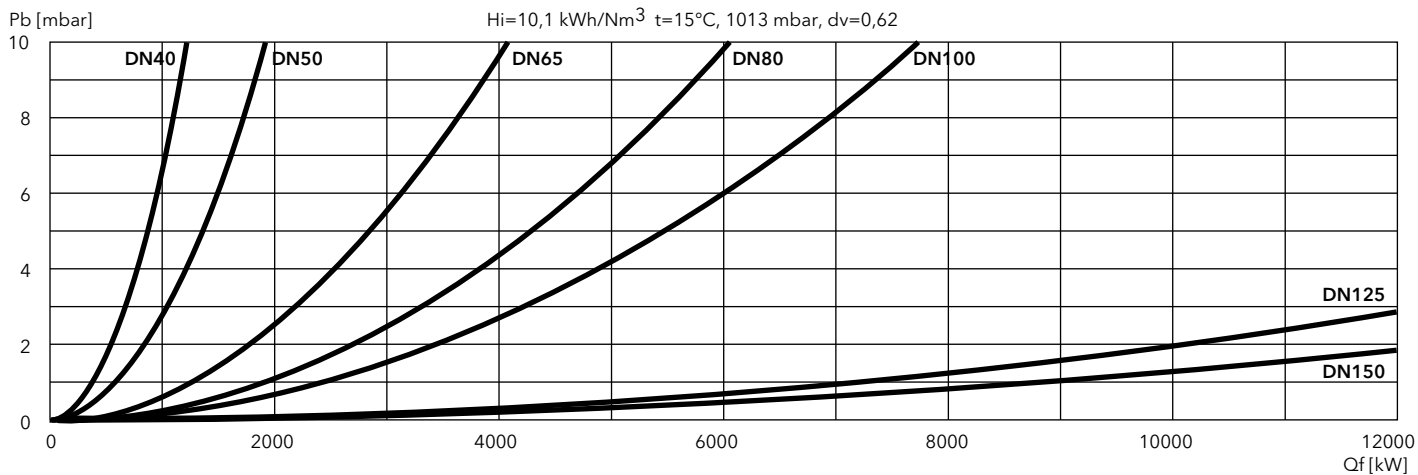

PRESSURE LOSSES (BURNER HEAD + GAS TRAIN)

EK EVO 9.6500 GL-EF3

DUNGS

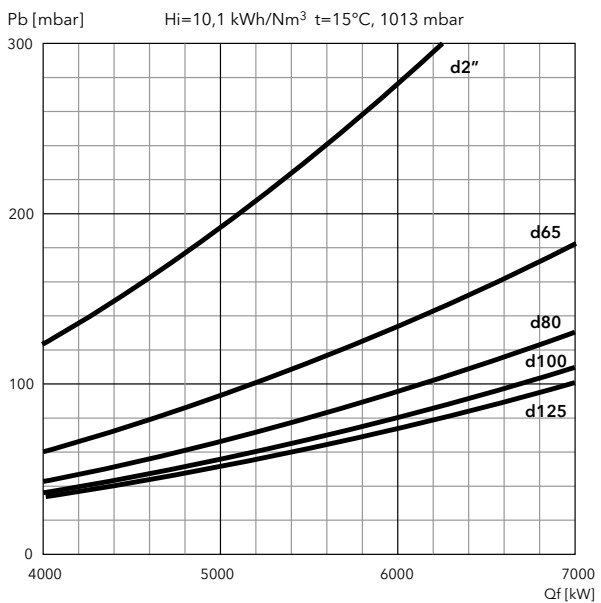

SIEMENS

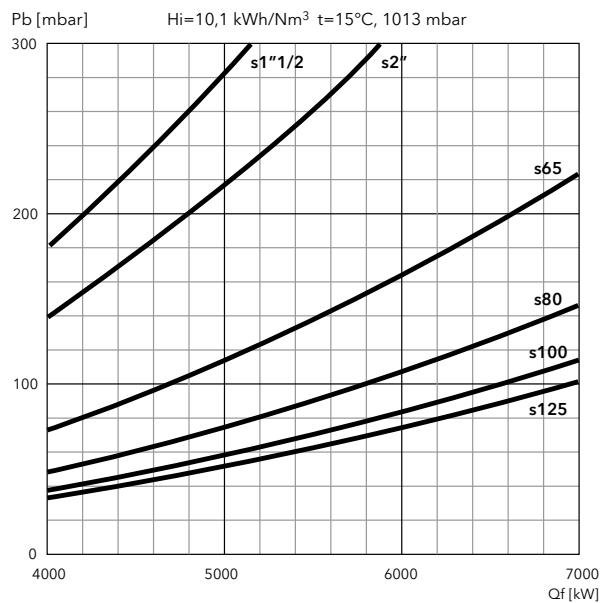

FILTERS

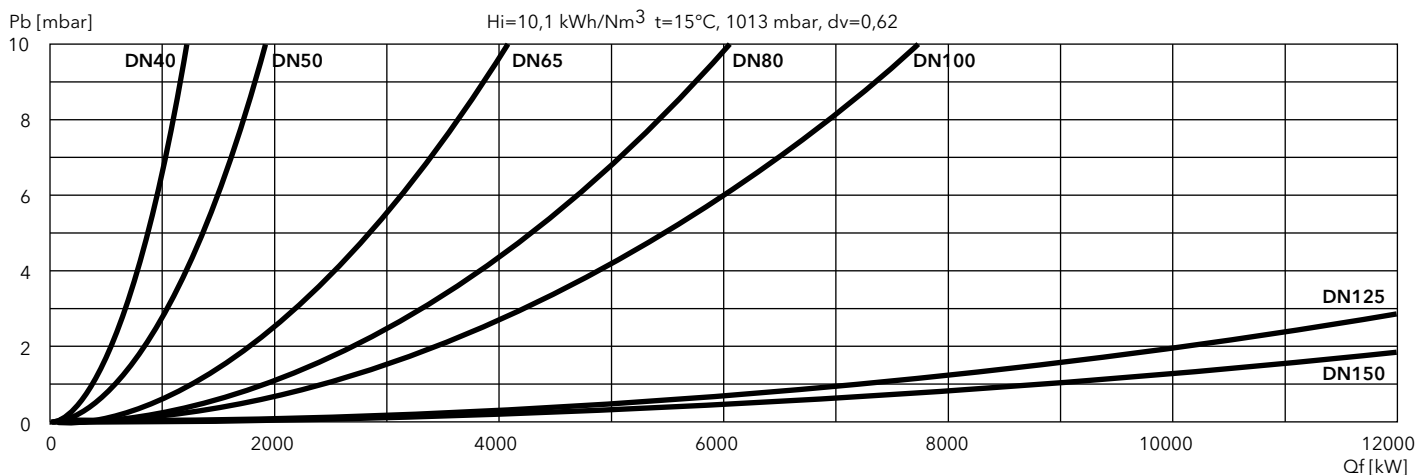

EKEVO 9 GL-EUF

1040 ... 9570 kW

2 stage progressive/modulating electronic in gas and in light oil (Low NOx class 3)

- **Fuels:** natural gas, Hi = 6,99 ... 11,39 kWh/Nm³;
light oil, viscosity 6 mm²/s at 20°C, Hi = 11,86 kWh/kg
- **Emission class:** Low NOx class 3 (≤80 mg/kWh) according to EN676 in gas
Low NOx class 3 (≤120 mg/kWh) according to EN267 in light oil
- **Protection level:** IP 41



TECHNICAL DATA

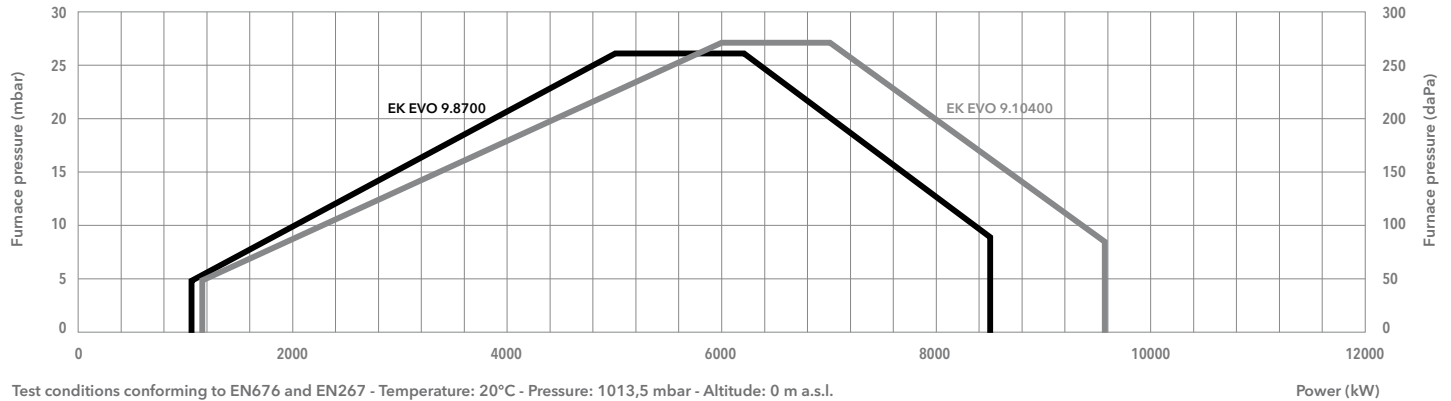

Test conditions conforming to EN676 and EN267 - Temperature: 20°C - Pressure: 1013,5 mbar - Altitude: 0 m a.s.l.

	EK EVO 9.8700 GL-EUF	EK EVO 9.10400 GL-EUF
Operating range gas	1040 - 8500 kW	1160 - 9570 kW
Operating range oil	1800 - 8500 kW	2550 - 9570 kW
Gas pressure	100 - 500 mbar (100 - 360 mbar for d457)	100 - 500 mbar (100 - 360 mbar for d457)
Gas connection	DN100	DN100
Control box / flame detector	BT300 / FFS08	BT300 / FFS08
Auxiliary voltage	1NPE AC 230 V - 50 Hz TN-S	1NPE AC 230 V - 50 Hz TN-S
Power supply	3PE AC 400 V - 50 Hz	3PE AC 400 V - 50 Hz
Fan motor	50 Hz - 18,5 kW	50 Hz - 22 kW
Acoustic level	<85,9 dB(A)	<86,6 dB(A)
CE certificate	0085CL0215	0085CL0215
Burner codes (body + head)	KN	3754827
	KM	3754831
	KL	3754835

GAS TRAINS

DUNGS

Model	Code
GT-d457-2" (*)	3750515
GT-d458-65	3750516
GT-d459-80	3750517
GT-d460-100	3750518

*: integrated filter

SIEMENS

Model	Code
GT-s457-2"	3750537
GT-s458-65	3750538
GT-s459-80	3750539
GT-s460-100	3750540
GT-s461-125	3750541

FILTERS

Model	Code
FG-Rp2"	3757200
FG-DN65	3757198
FG-DN80	3757201
FG-DN100	3757195
FG-DN125	3757209

 **Pressure drops graphs:** see following pages
Dimensions of gas trains and gas filters: see pag. 207



DIMENSIONS (mm)

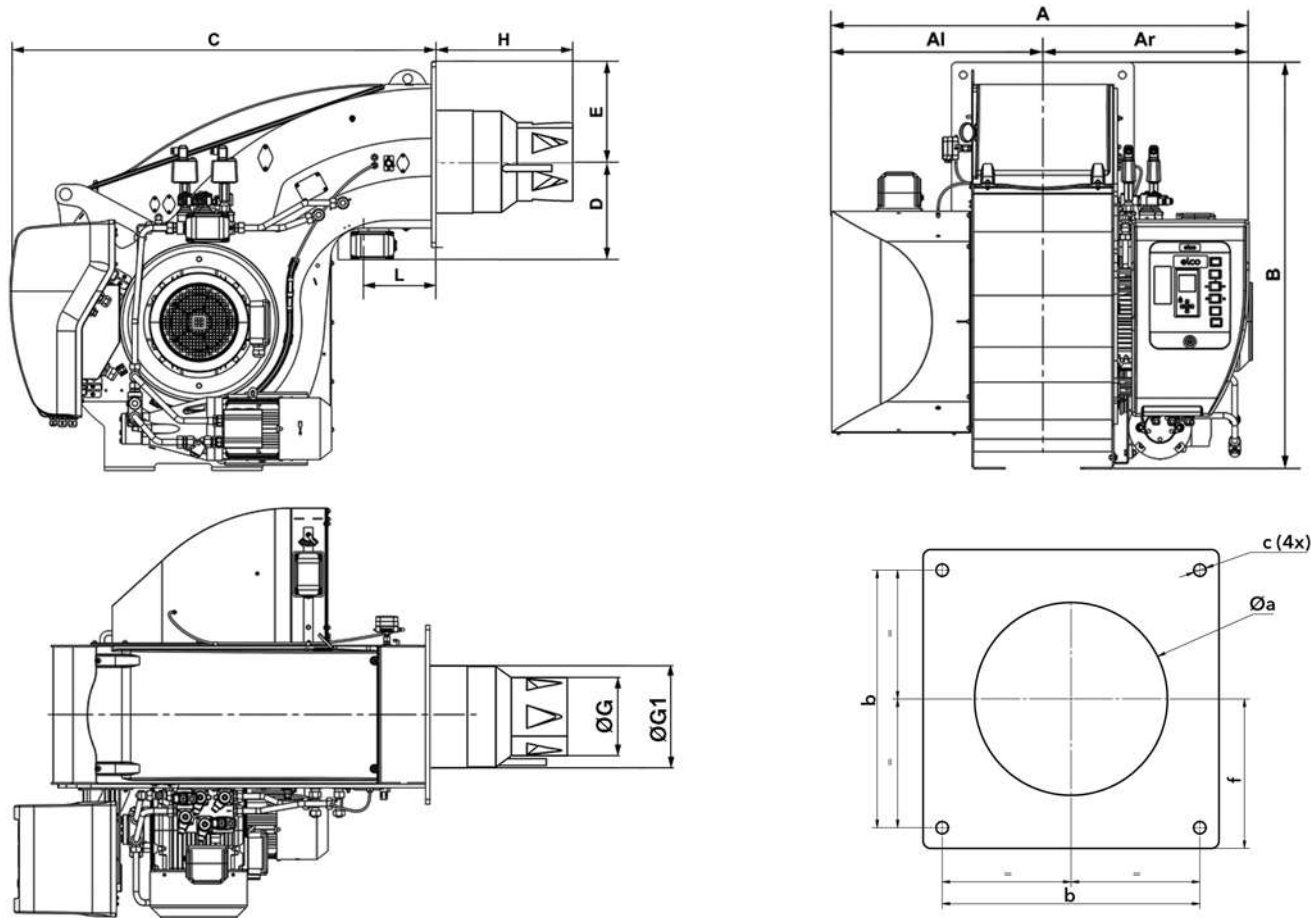

Model	A	Al	Ar	B	C	D	E	ØG	ØG1	H			L	Øa	b	c	f
										KN	KM	KL					
EK EVO 9.8700	1336	670	666	1291	1348	332	293	325	438,5	575	725	875	230	445-480	505	M20	293
EK EVO 9.10400	1400	670	730	1291	1348	332	293	335	438,5	575	725	875	230	445-480	505	M20	293

PACKAGING

The burner is delivered on a pallet in 2 packages containing:

- burner body with mounted combustion head, boiler fixing accessories and technical documentation;
- gas train and filter.

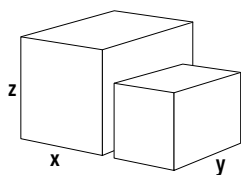

Models	Dimensions (mm)			Gross weight (kg)	
	X	Y	Z		
EK EVO 9.8700 GL-EUF	KN	2300	1500	1461	369
	KM	2300	1500	1461	369
	KL	2300	1500	1461	369
EK EVO 9.10400 GL-EUF	KN	2300	1500	1461	369
	KM	2300	1500	1461	369
	KL	2300	1500	1461	369

PRESSURE LOSSES (BURNER HEAD + GAS TRAIN)

EK EVO 9.8700 GL-EUF

DUNGS

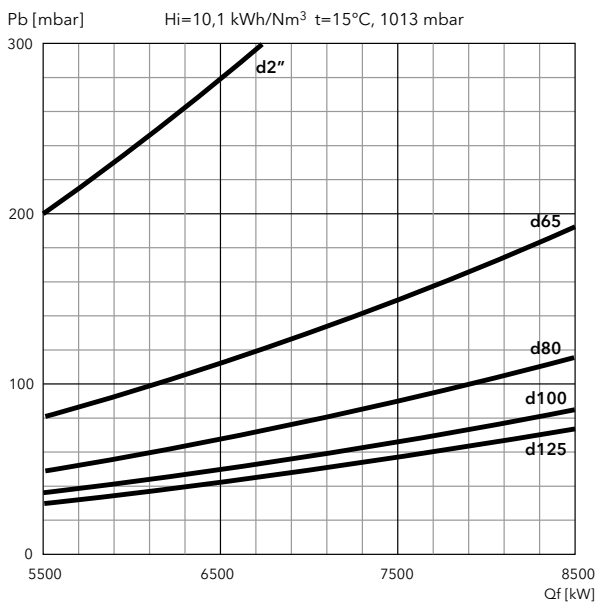

SIEMENS

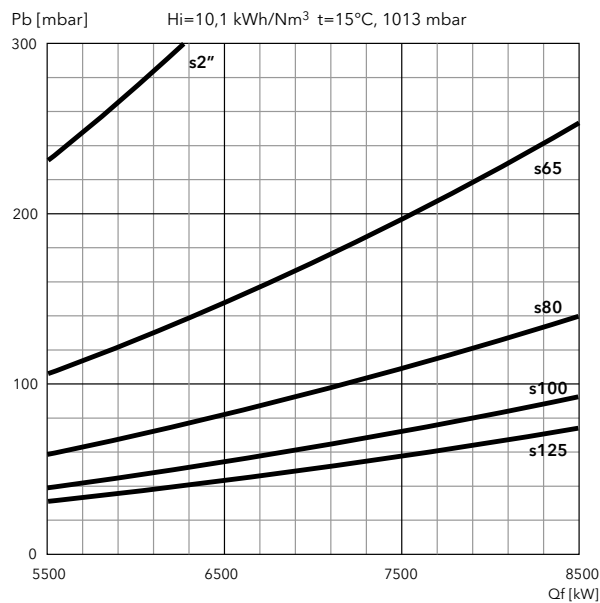

FILTERS

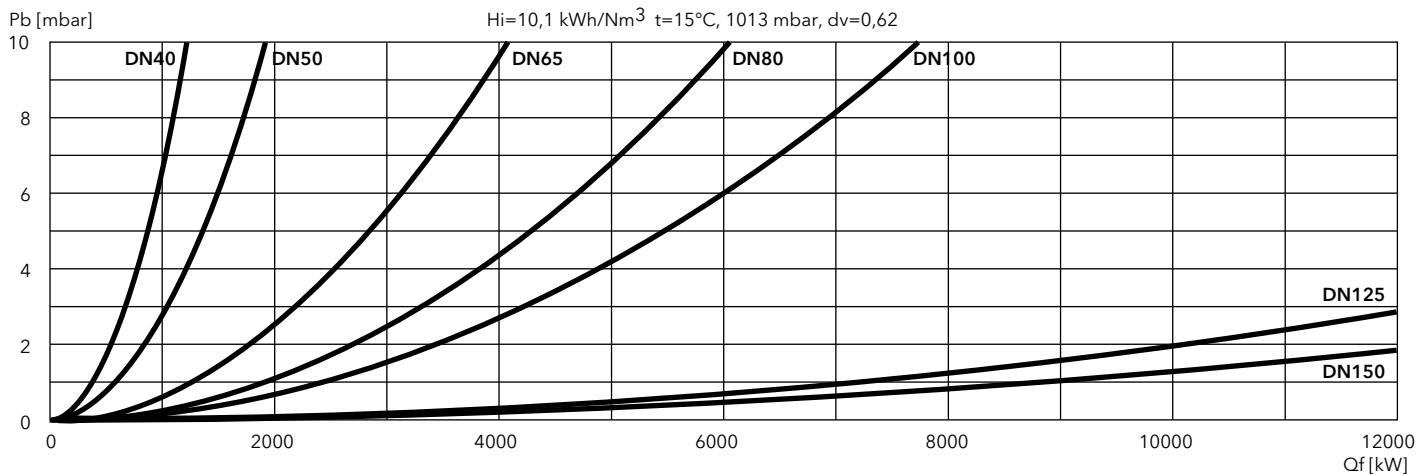

PRESSURE LOSSES (BURNER HEAD + GAS TRAIN)

EK EVO 9.10400 GL-EUF

DUNGS

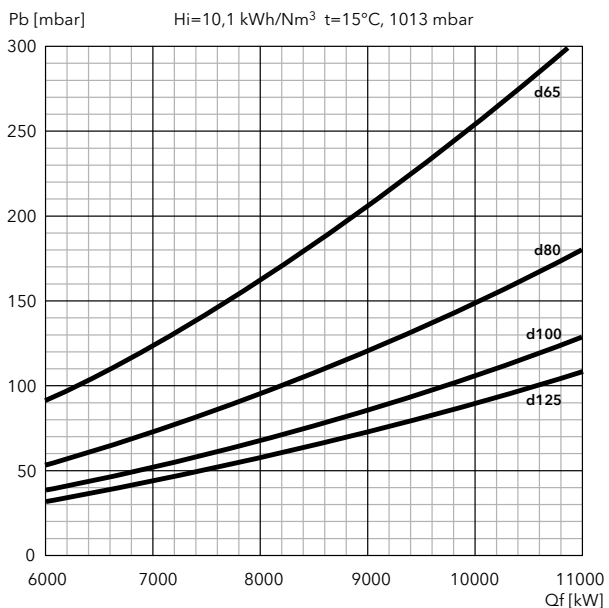

SIEMENS

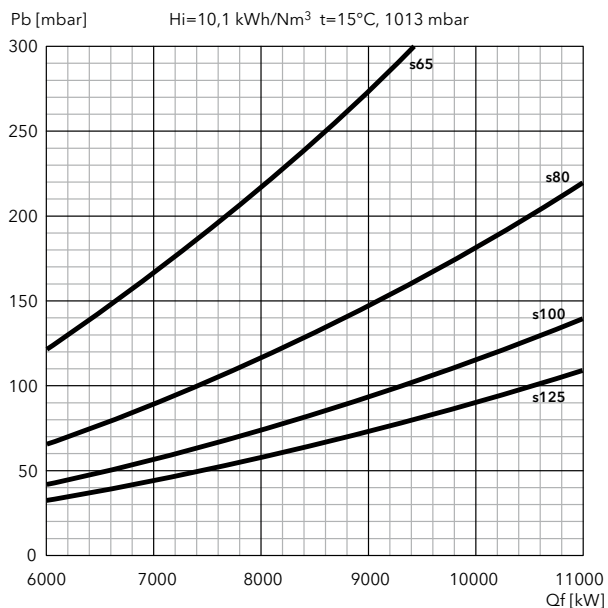

FILTERS

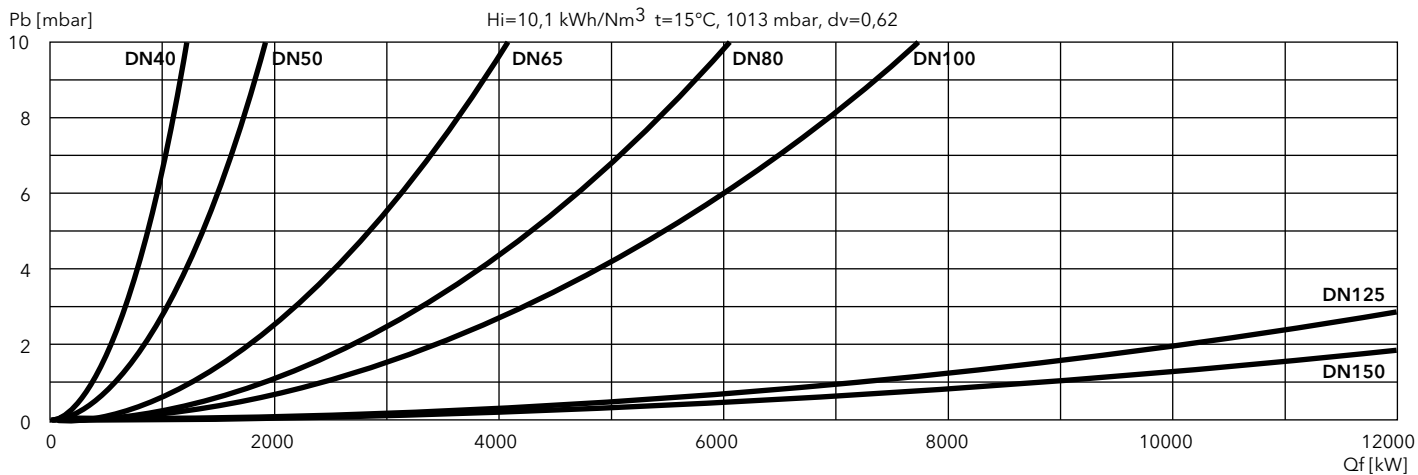

EK EVO 6 L-E, EK EVO 7 L-E

510 ... 4900 kW

2 stage progressive/modulating electronic

- **Fuels:** light oil, viscosity 6 mm²/s at 20°C, Hi = 11,86 kWh/kg
- **Emission class:** Low NOx class 2 (≤185 mg/kWh) according to EN267
- **Protection level:** IP 41



TECHNICAL DATA

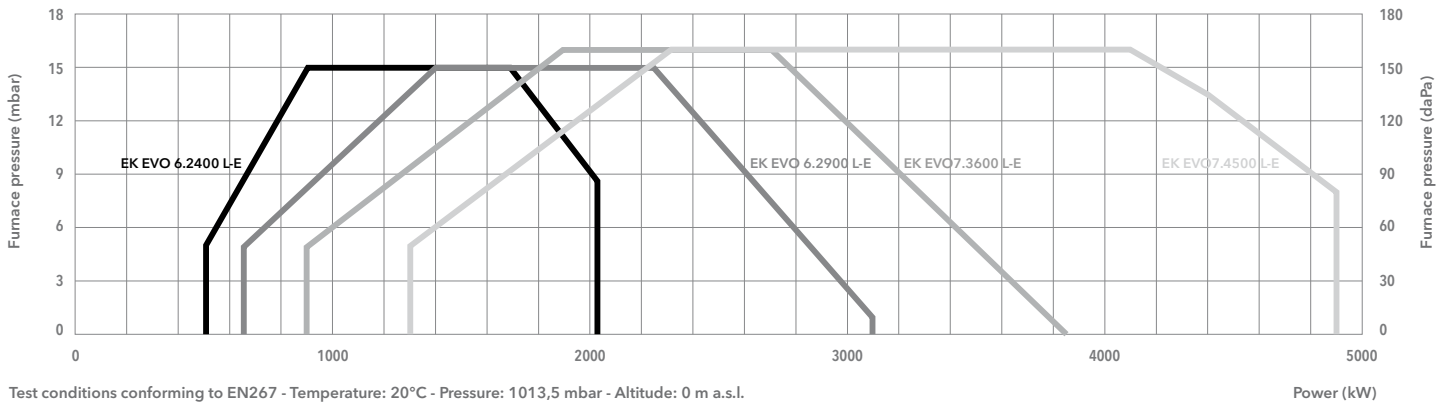

	EK EVO 6.2400 L-E	EK EVO 6.2900 L-E	EK EVO 7.3600 L-E	EK EVO 7.4500 L-E
Operating range	510 - 2030 kW	650 - 3100 kW	900 - 3850 kW	1300 - 4900 kW
Fuel connection	DN20 x 1500 mm / R 1/2"	DN20 x 1500 mm / R 1/2"	DN20 x 1500 mm / R 3/4"	DN20 x 1500 mm / R 3/4"
Auxiliary voltage	1NPE AC 230 V - 50 Hz TN-S	1NPE AC 230 V - 50 Hz TN-S	1NPE AC 230 V - 50 Hz TN-S	1NPE AC 230 V - 50 Hz TN-S
Power supply	3PE AC 400 V - 50 Hz	3PE AC 400 V - 50 Hz	3PE AC 400 V - 50 Hz	3PE AC 400 V - 50 Hz
Control box / flame detector	BT300 / KLC20	BT300 / KLC20	BT300 / KLC20	BT300 / KLC20
Fan motor	50 Hz - 3 kW	50 Hz - 4 kW	50 Hz - 5,5 kW	50 Hz - 7,5 kW
Pump	SUNTEC TA3	SUNTEC TA3	SUNTEC TA4	SUNTEC TA5
Motor pump	50 Hz - 0,75 kW	50 Hz - 0,75 kW	50 Hz - 1,1 kW	50 Hz - 1,5 kW
Acoustic level	<77 dB(A)	<77 dB(A)	<81 dB(A)	<82,5 dB(A)
CE certificate	0085CL0215	0085CL0215	0085CL0215	0085CL0215
Burner codes (body + head)	KN	3756752	3756758	3756761
	KM	3756751	3756754	3756760
	KL	3756750	3756753	3756759

DIMENSIONS (mm)

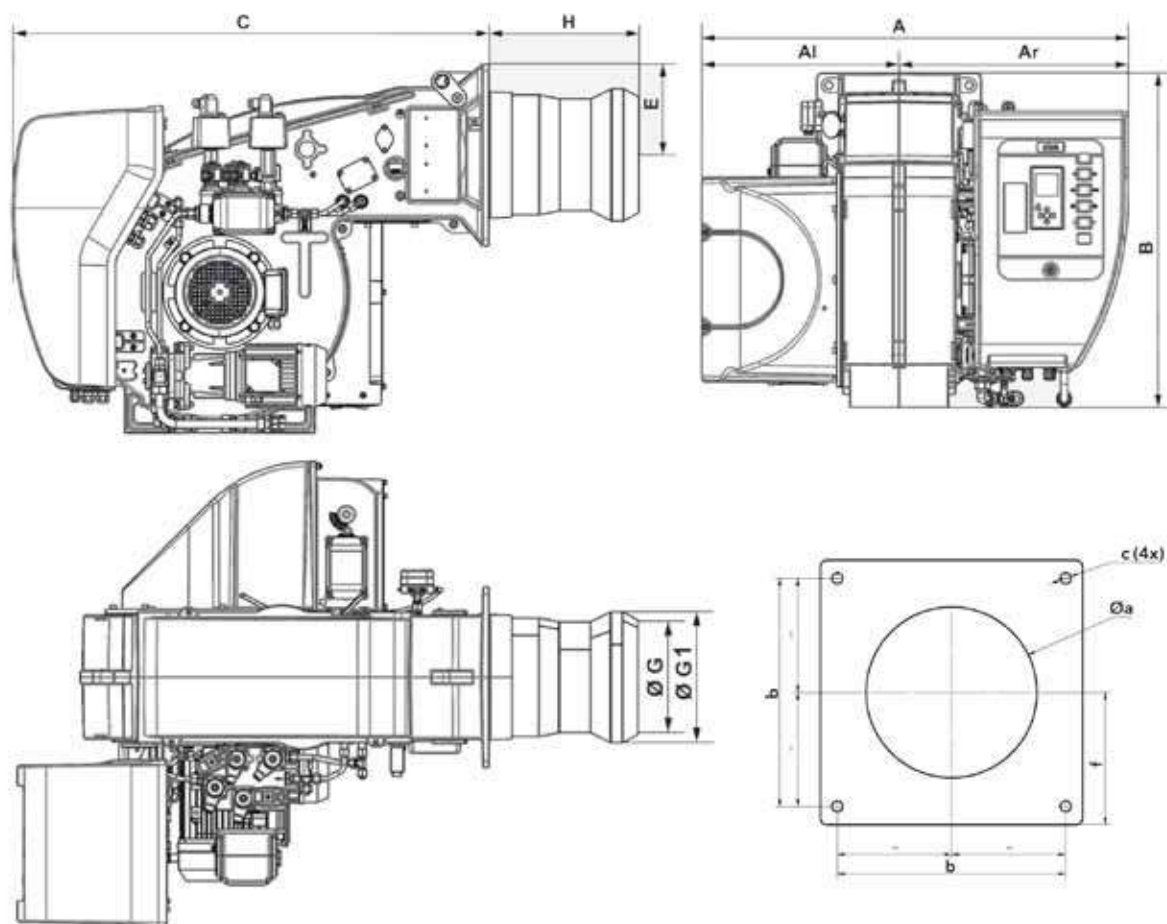

Model	A	AI	Ar	B	C	E	ØG	ØG1	H			Øa	b	c	f
									KN	KM	KL				
EK EVO 6.2400 L-E	1035	479	556	812	1046	200	250	290	330	450	570	300-340	340	M16	200
EK EVO 6.2900 L-E	1035	479	556	812	1046	200	265	310	330	450	570	320-340	340	M16	200
EK EVO 7.3600 L-E	1107	510	597	941	1121	235	280	340	375	505	635	340-400	400	M16	235
EK EVO 7.4500 L-E	1107	510	597	941	1121	235	310	370	375	505	635	380-400	400	M16	235

PACKAGING

The burner is delivered on a pallet in 1 package containing:

- burner body with mounted combustion head, boiler fixing accessories, technical data including electrical diagram, exploded view, spare parts list, and instruction manual.

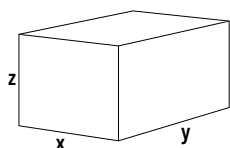

Models	Dimensions (mm)			Gross weight (kg)	
	X	Y	Z		
EK EVO 6.2400 L-E	KN	2070	1420	990	315
	KM	2070	1420	990	315
	KL	2070	1420	990	315
EK EVO 6.2900 L-E	KN	2070	1420	990	325
	KM	2070	1420	990	325
	KL	2070	1420	990	325
EK EVO 7.3600 L-E	KN	2070	1420	1130	360
	KM	2070	1420	1130	360
	KL	2070	1420	1130	360
EK EVO 7.4500 L-E	KN	2070	1420	1130	370
	KM	2070	1420	1130	370
	KL	2070	1420	1130	370

EK EVO 8 L-E, EK EVO 9 L-E

1210 ... 10620 kW

2 stage progressive/modulating electronic

- **Fuels:** light oil, viscosity 6 mm²/s at 20°C, Hi = 11,86 kWh/kg
- **Emission class:** Low NOx class 2 (≤185 mg/kWh) according to EN267
- **Protection level:** IP 41



TECHNICAL DATA

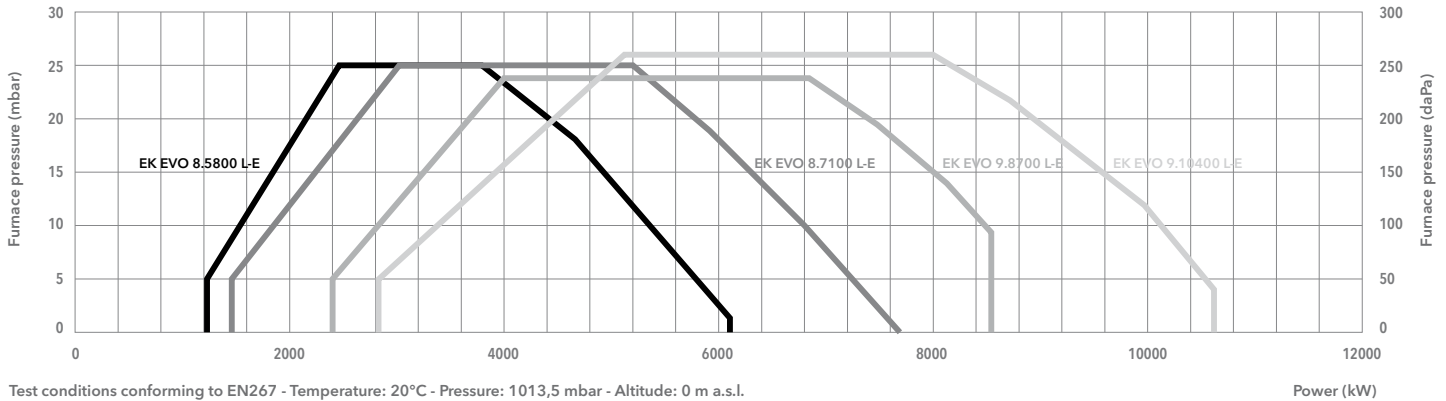

Test conditions conforming to EN267 - Temperature: 20°C - Pressure: 1013,5 mbar - Altitude: 0 m a.s.l.

	EK EVO 8.5800 L-E	EK EVO 8.7100 L-E	EK EVO 9.8700 L-E	EK EVO 9.10400 L-E
Operating range	1210 - 6100 kW	1450 - 7700 kW	2400 - 8530 kW	2820 - 10620 kW
Fuel connection	DN20 x 1500 mm / R 3/4"	DN20 x 1500 mm / R 3/4"	DN20 x 1500 mm / R 3/4"	DN25 x 1500 mm / R 1"
Auxiliary voltage	1NPE AC 230 V - 50 Hz TN-S	1NPE AC 230 V - 50 Hz TN-S	1NPE AC 230 V - 50 Hz TN-S	1NPE AC 230 V - 50 Hz TN-S
Power supply	3PE AC 400 V - 50 Hz	3PE AC 400 V - 50 Hz	3PE AC 400 V - 50 Hz	3PE AC 400 V - 50 Hz
Control box / flame detector	BT300 / KLC20	BT300 / KLC20	BT300 / KLC20	BT300 / KLC20
Fan motor	50 Hz - 11 kW	50 Hz - 15 kW	50 Hz - 18,5 kW	50 Hz - 22 kW
Pump	SMG1630 - 1700 l/h	SMG1630 - 1700 l/h	SMG1630 - 1700 l/h	SMG1631 - 2200 l/h
Motor pump	50 Hz - 3 kW	50 Hz - 3 kW	50 Hz - 3 kW	50 Hz - 4 kW
Acoustic level	<80,5 dB(A)	<82,6 dB(A)	<85,5 dB(A)	<86,2 dB(A)
CE certificate	0085CL0215	0085CL0215	0085CL0215	0085CL0215
Burner codes (body + head)	KN	3756764	3756770	3756773
	KM	3756763	3756766	3756772
	KL	3756762	3756765	3756771



DIMENSIONS (mm)

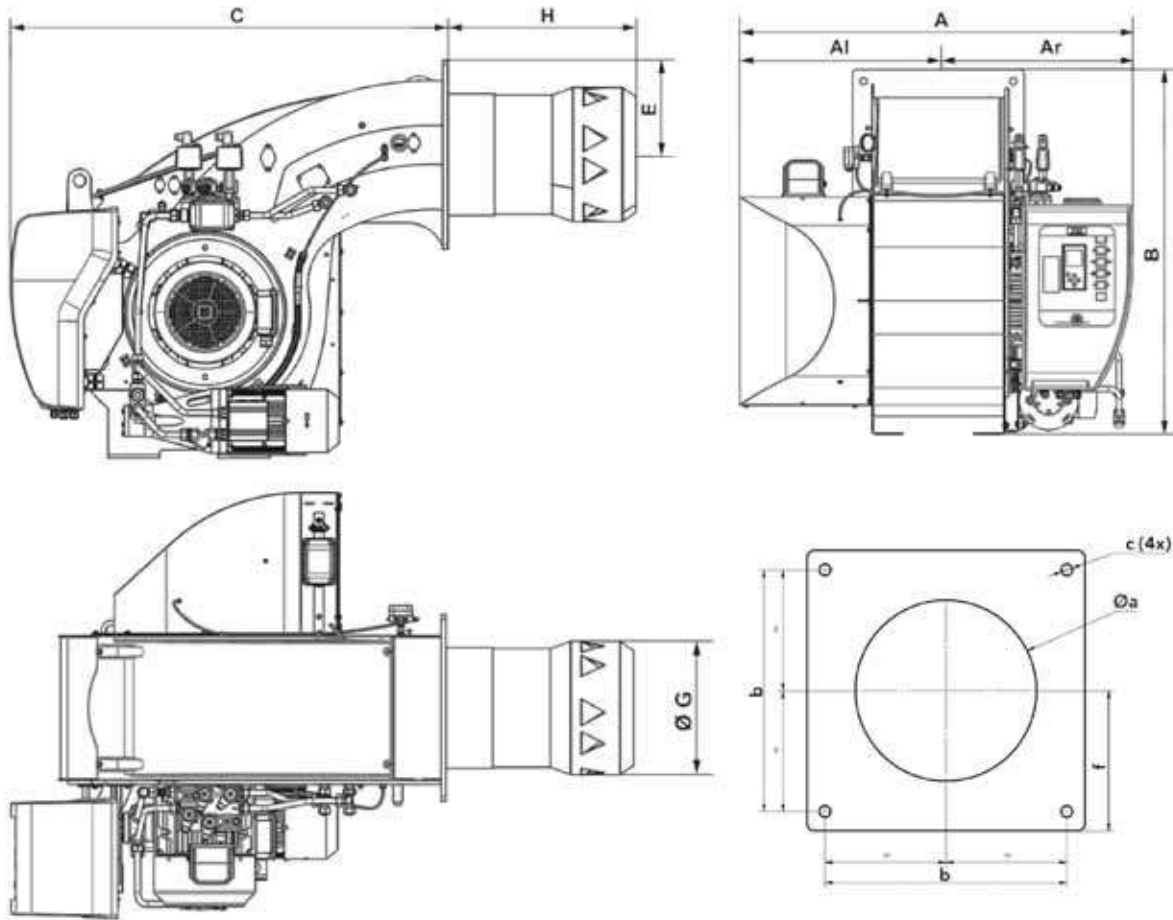

Model	A	Al	Ar	B	C	E	ØG	H			Øa	b	c	f
								KN	KM	KL				
EK EVO 8.5800 L-E	1325	670	655	1231	1351	293	400	562	702	842	430-480	505	M20	293
EK EVO 8.7100 L-E	1325	670	655	1231	1351	293	415	583	723	863	445-480	505	M20	293
EK EVO 9.8700 L-E	1325	670	655	1291	1348	293	431,5	355	505	655	445-480	505	M20	293
EK EVO 9.10400 L-E	1400	670	730	1291	1348	293	431,5	355	505	655	445-480	505	M20	293

PACKAGING

The burner is delivered on a pallet in 1 package containing:

- burner body with mounted combustion head, boiler fixing accessories, technical data including electrical diagram, exploded view, spare parts list, and instruction manual.

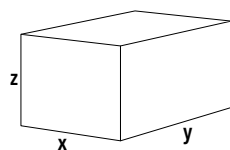

Models	Dimensions (mm)			Gross weight (kg)	
	X	Y	Z		
EK EVO 8.5800 L-E	KN	2300	1500	1396	630
	KM	2300	1500	1396	637
	KL	2300	1500	1396	643
EK EVO 8.7100 L-E	KN	2300	1500	1396	630
	KM	2300	1500	1396	639
	KL	2300	1500	1396	645
EK EVO 9.8700 L-E	KN	2300	1500	1396	652
	KM	2300	1500	1396	660
	KL	2300	1500	1396	667
EK EVO 9.10400 L-E	KN	2300	1500	1461	662
	KM	2300	1500	1461	670
	KL	2300	1500	1461	677

EK EVO 6 L-EF3, EK EVO 7 L-EF3

360 ... 4820 kW

2 stage progressive/modulating electronic (Low NOx class 3)

- **Fuels:** light oil, viscosity 6 mm²/s at 20°C, Hi = 11,86 kWh/kg
- **Emission class:** Low NOx class 3 (≤120 mg/kWh) according to EN267
- **Protection level:** IP 41



TECHNICAL DATA

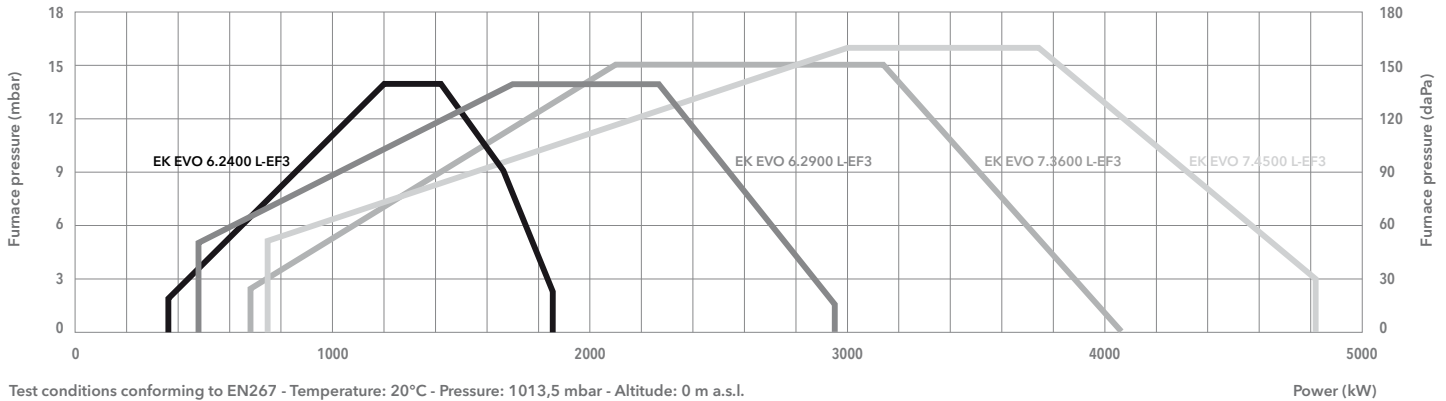

Test conditions conforming to EN267 - Temperature: 20°C - Pressure: 1013,5 mbar - Altitude: 0 m a.s.l.

	EK EVO 6.2400 L-EF3	EK EVO 6.2900 L-EF3	EK EVO 7.3600 L-EF3	EK EVO 7.4500 L-EF3
Operating range	360 - 1850 kW	480 - 2950 kW	680 - 4070 kW	740 - 4820 kW
Fuel connection	DN20 x 1500 mm / R 1/2"	DN20 x 1500 mm / R 1/2"	DN20 x 1500 mm / R 3/4"	DN20 x 1500 mm / R 3/4"
Auxiliary voltage	1NPE AC 230 V - 50 Hz TN-S	1NPE AC 230 V - 50 Hz TN-S	1NPE AC 230 V - 50 Hz TN-S	1NPE AC 230 V - 50 Hz TN-S
Power supply	3PE AC 400 V - 50 Hz	3PE AC 400 V - 50 Hz	3PE AC 400 V - 50 Hz	3PE AC 400 V - 50 Hz
Control box / flame detector	BT300 / KLC20	BT300 / KLC20	BT300 / KLC20	BT300 / KLC20
Fan motor	50 Hz - 3 kW	50 Hz - 4 kW	50 Hz - 7,5 kW	50 Hz - 7,5 kW
Pump	SUNTECTA3	SUNTECTA3	SUNTECTA4	SUNTECTA5
Motor pump	50 Hz - 0,75 kW	50 Hz - 0,75 kW	50 Hz - 1,1 kW	50 Hz - 1,5 kW
Acoustic level	<76 dB(A)	<77 dB(A)	<83 dB(A)	<81 dB(A)
CE certificate	0085CL0215	0085CL0215	0085CL0215	0085CL0215
Burner codes (body + head)	KN	3756774	3756775	3756777
	KM	3756779	3756780	3756782
	KL	3756783	3756784	3756786



DIMENSIONS (mm)

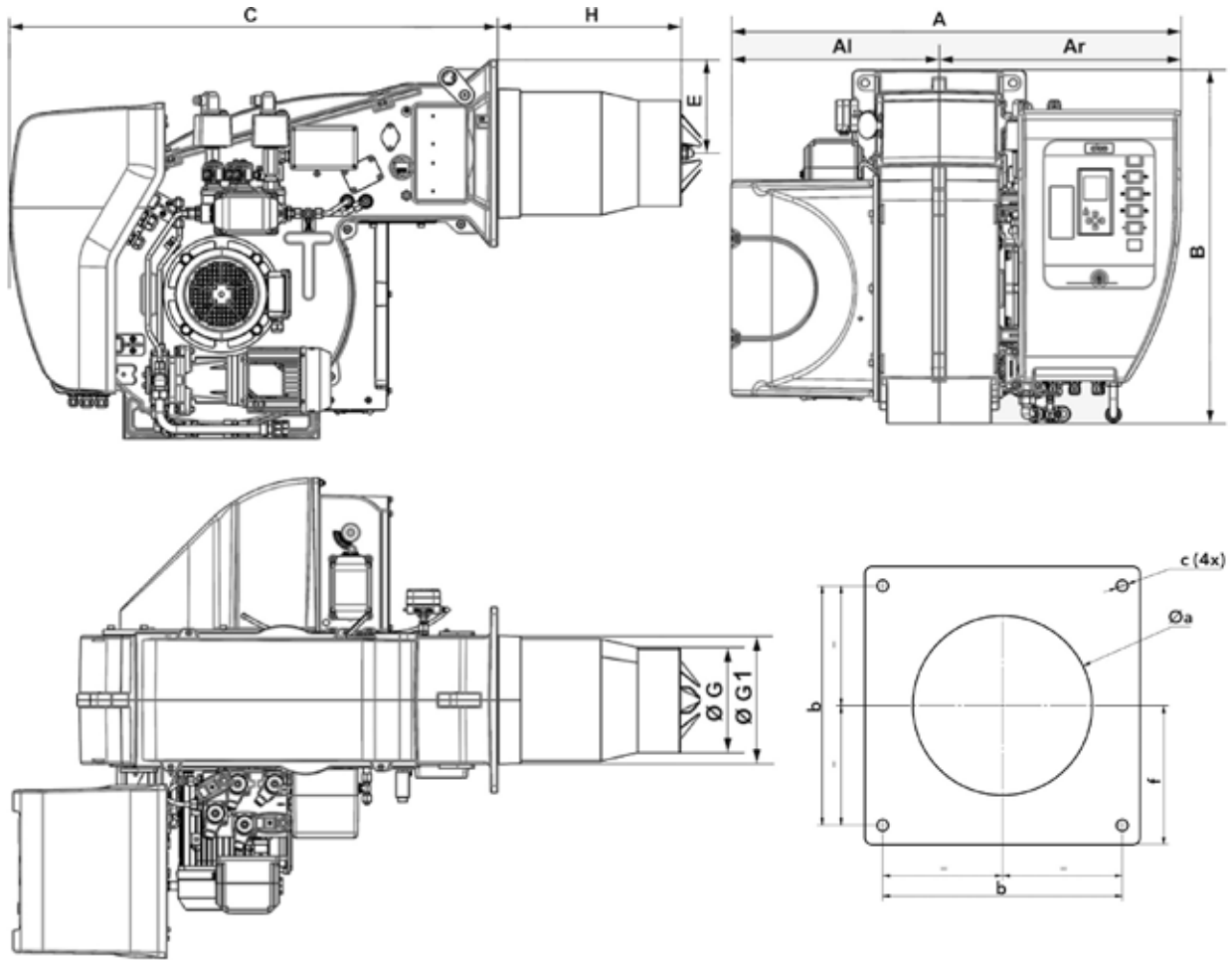

Model	A	AI	Ar	B	C	E	ØG	ØG1	H			Øa	b	c	f
									KN	KM	KL				
EK EVO 6.2400	1035	479	556	812	1046	200	227	290	400	520	640	300-340	340	M16	200
EK EVO 6.2900	1035	479	556	812	1046	200	263	290	400	520	640	300-340	340	M16	200
EK EVO 7	1107	510	597	941	1121	255	325	325	375	505	635	360-400	400	M16	235

PACKAGING

The burner is delivered on a pallet in 1 package containing:

- burner body with mounted combustion head, boiler fixing accessories, technical data including electrical diagram, exploded view, spare parts list, and instruction manual.

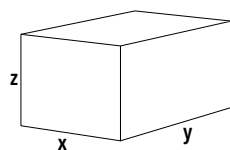

Models	Dimensions (mm)			Gross weight (kg)	
	X	Y	Z		
EK EVO 6.2400 L-EF3	KN	2070	1420	990	315
	KM	2070	1420	990	315
	KL	2070	1420	990	315
EK EVO 6.2900 L-EF3	KN	2070	1420	990	325
	KM	2070	1420	990	325
	KL	2070	1420	990	325
EK EVO 7.3600 L-EF3	KN	2070	1420	1150	360
	KM	2070	1420	1150	360
	KL	2070	1420	1150	360
EK EVO 7.4500 L-EF3	KN	2070	1420	1150	370
	KM	2070	1420	1150	370
	KL	2070	1420	1150	370

EK EVO 8 L-EF3, EK EVO 9 L-EF3

1100 ... 6600 kW

2 stage progressive/modulating electronic (Low NOx class 3)

- **Fuels:** light oil, viscosity 6 mm²/s at 20°C, Hi = 11,86 kWh/kg
- **Emission class:** Low NOx class 3 (≤120 mg/kWh) according to EN267
- **Protection level:** IP 41

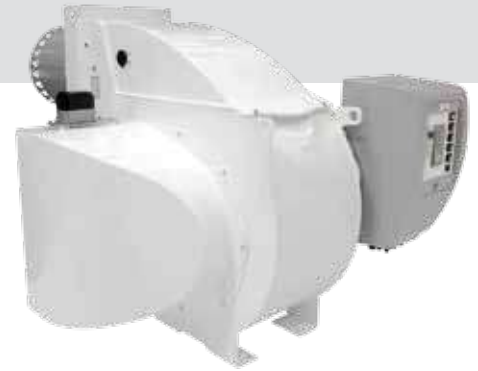

TECHNICAL DATA

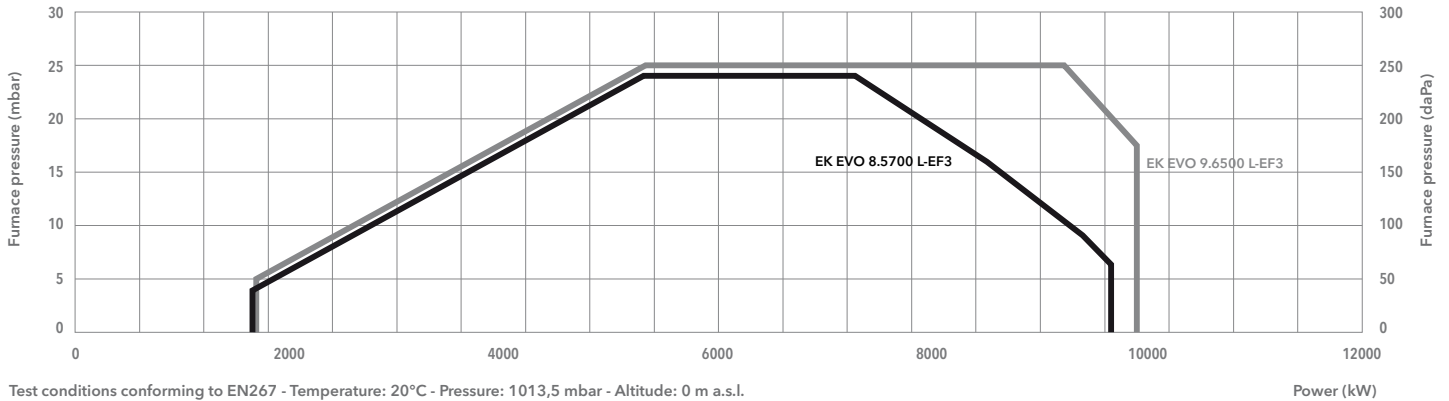

Test conditions conforming to EN267 - Temperature: 20°C - Pressure: 1013,5 mbar - Altitude: 0 m a.s.l.

	N8.5700 L-EF3	N9.6500 L-EF3
Operating range	1100 - 6450 kW	1200 - 6600 kW
Fuel connection	DN20 x 1500 mm / R 3/4"	DN20 x 1500 mm / R 3/4"
Auxiliary voltage	1NPE AC 230 V - 50 Hz TN-S	1NPE AC 230 V - 50 Hz TN-S
Power supply	3PE AC 400 V - 50 Hz	3PE AC 400 V - 50 Hz
Control box / flame detector	BT300 / KLC20	BT300 / KLC20
Fan motor	50 Hz - 15 kW	50 Hz - 22 kW
Pump	SMG1630 - 1700 l/h	SMG1630 - 1700 l/h
Motor pump	50 Hz - 3 kW	50 Hz - 3 kW
Acoustic level	<83,9 dB(A)	<87,9 dB(A)
CE certificate	0085CL0215	0085CL0215
Burner codes (body + head)	KN	3756799
	KM	3756803
	KL	3756807
		3756800
		3756804
		3756808



DIMENSIONS (mm)

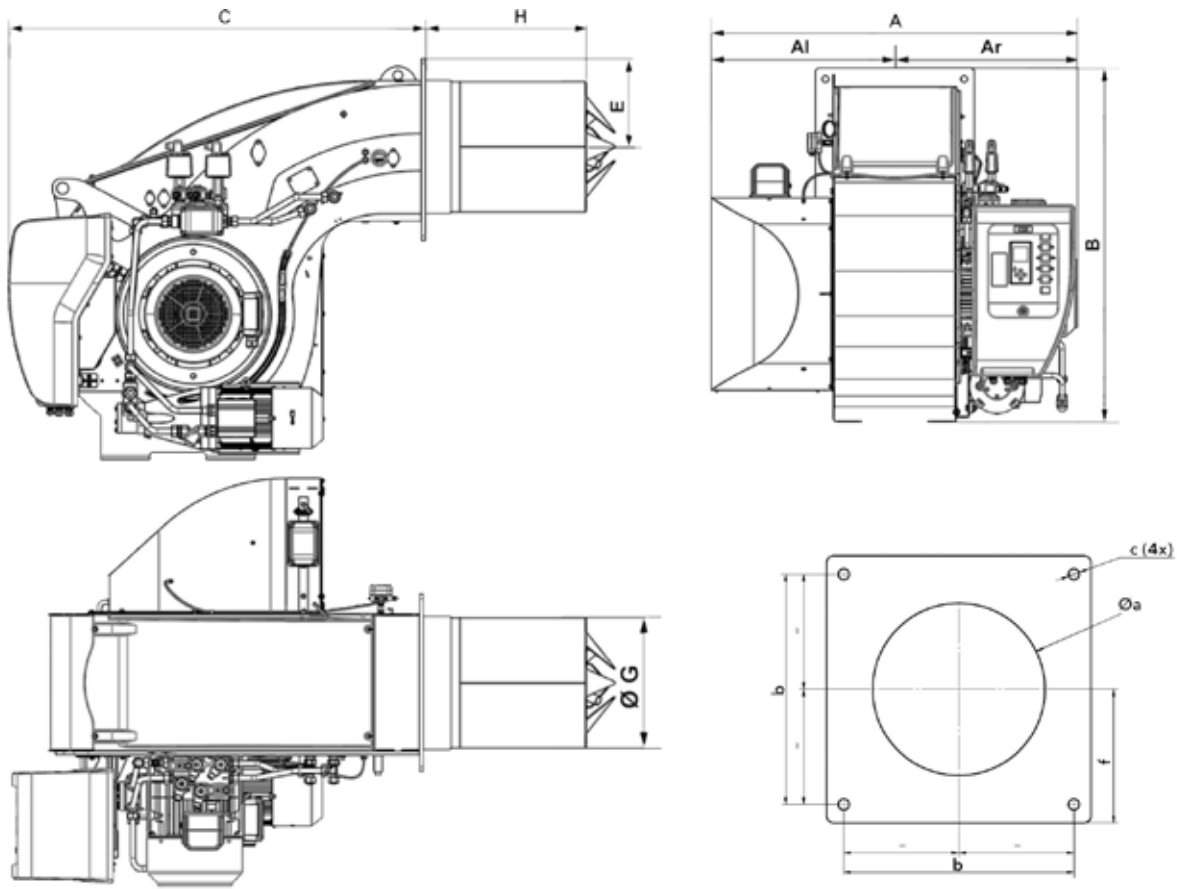

Model	A	Al	Ar	B	C	E	ØG	H			Øa	b	c	f
								KN	KM	KL				
EK EVO 8.5700 L-EF3	1325	670	655	1231	1351	293	369	528	668	808	380-410	505	M20	293
EK EVO 9.6500 L-EF3	1400	670	730	1291	1348	293	431,5	543	693	843	445-480	505	M20	293

PACKAGING

The burner is delivered on a pallet in 1 package containing:

- burner body with mounted combustion head, boiler fixing accessories, technical data including electrical diagram, exploded view, spare parts list, and instruction manual.

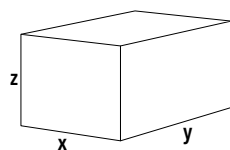

Models	Dimensions (mm)			Gross weight (kg)	
	X	Y	Z		
EK EVO 8.5700 L-EF3	KN	2300	1500	1396	600
	KM	2300	1500	1396	608
	KL	2300	1500	1396	615
EK EVO 9.6500 L-EF3	KN	2300	1500	1461	670
	KM	2300	1500	1461	678
	KL	2300	1500	1461	685

EK EVO 9 L-EUF

1800 ... 9570 kW

2 stage progressive/modulating electronic (Low NOx class 3)

- **Fuels:** light oil, viscosity 6 mm²/s at 20°C, Hi = 11,86 kWh/kg
- **Emission class:** Low NOx class 3 (≤120 mg/kWh) according to EN267
- **Protection level:** IP 41

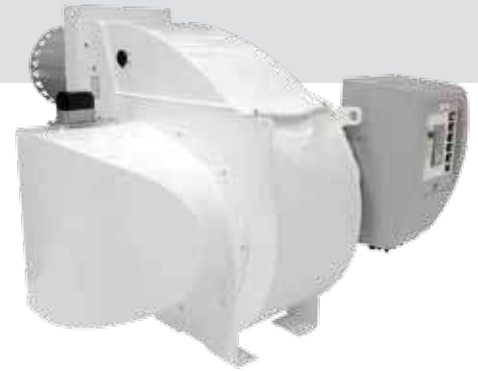

TECHNICAL DATA

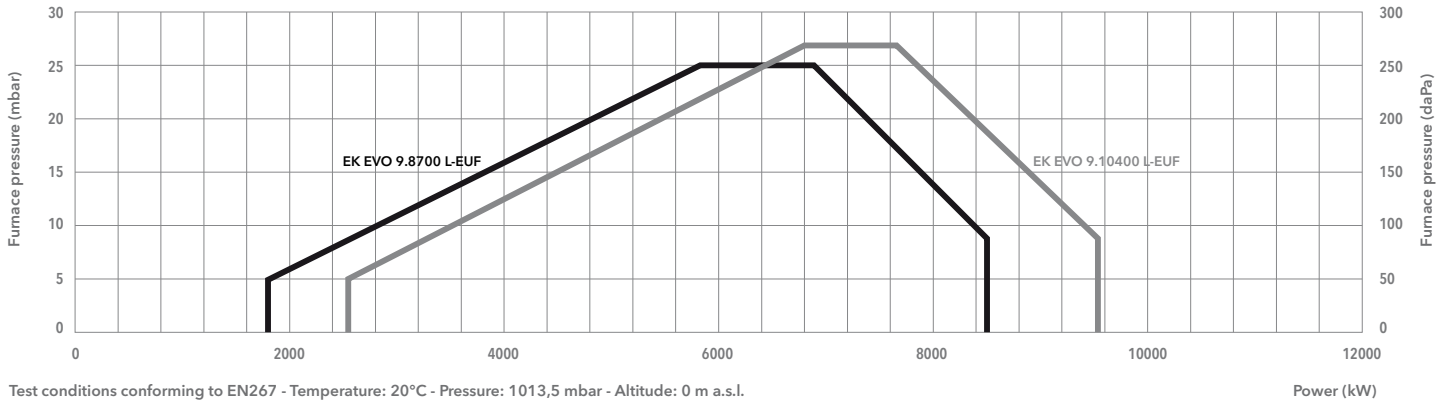

Test conditions conforming to EN267 - Temperature: 20°C - Pressure: 1013,5 mbar - Altitude: 0 m a.s.l.

		N9.8700 L-EUF	N9.10400 L-EUF
Operating range		1800 - 8500 kW	2550 - 9570 kW
Fuel connection		DN20 x 1500 mm / R 3/4"	DN25 x 1500 mm / R 1"
Auxiliary voltage		1NPE AC 230 V - 50 Hz TN-S	1NPE AC 230 V - 50 Hz TN-S
Power supply		3PE AC 400 V - 50 Hz	3PE AC 400 V - 50 Hz
Control box / flame detector		BT300 / KLC20	BT300 / KLC20
Fan motor		50 Hz - 18,5 kW	50 Hz - 22 kW
Pump		SMG1630 - 1700 l/h	SMG1631 - 2200 l/h
Motor pump		50 Hz - 3 kW	50 Hz - 4 kW
Acoustic level		<85,9 dB(A)	<86,6 dB(A)
CE certificate		0085CL0215	0085CL0215
Burner codes (body + head)	KN	3756801	3756802
	KM	3756805	3756806
	KL	3756809	3756810



DIMENSIONS (mm)

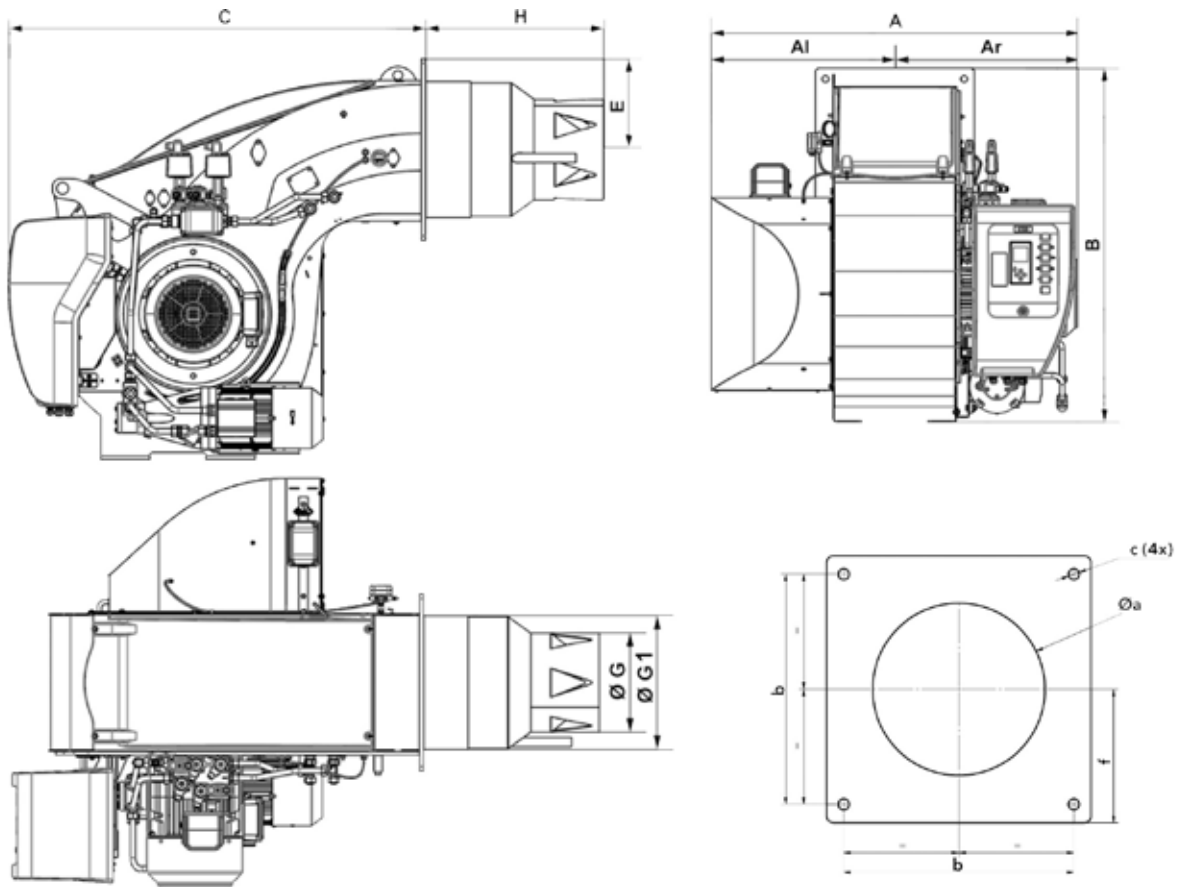

Model	A	Al	Ar	B	C	E	ØG	ØG1	H			Øa	b	c	f
									KN	KM	KL				
EK EVO 9.8700 L-EUF	1336	670	666	1291	1348	293	320	431,5	575	725	875	445-480	505	M20	293
EK EVO 9.10400 L-EUF	1400	670	730	1291	1348	293	330	431,5	575	725	875	445-480	505	M20	293

PACKAGING

The burner is delivered on a pallet in 1 package containing:
 • burner body with mounted combustion head, boiler fixing accessories, technical data including electrical diagram, exploded view, spare parts list, and instruction manual.

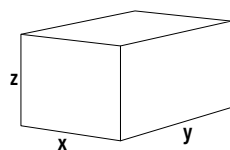

Models	Dimensions (mm)			Gross weight (kg)	
	X	Y	Z		
EK EVO 9.8700 L-EUF	KN	2300	1500	1461	652
	KM	2300	1500	1461	660
	KL	2300	1500	1461	667
EK EVO 9.10400 L-EUF	KN	2300	1500	1461	662
	KM	2300	1500	1461	670
	KL	2300	1500	1461	677

BURNER VARIANTS (options already mounted in factory)

LCM MODULE (for communication, O₂ control, frequency converter)

Module mounted in factory, requested for O₂ control, Variatron and communication buses connections (the module is available also on request as a separate kit) Note: only one LCM module is necessary for these 3 options For all dual fuel models the LCM module is already included	3751645
---	----------------

MODULATING OPERATION

RS55 (Regulator RWF55 + instruction manual) , mounted in factory on the switch cabinet – to be connected to the appropriate probe (see "BURNER KITS" session)	for EK EVO 6...9 G... and EK EVO 6...9 GL-E/GL-EF3/GL-EUF	3751646
	for EK EVO 6/7 GL-EZ3	3751647

FREQUENCY CONVERTER ARRANGEMENT

Burner prepared to be connected to an external frequency converter; this variant includes the VSM module to control the frequency converter.

NOTE: one LCM module is required and must be ordered separately

EK EVO 6.2400 G-E/G-EF3 prepared for an external frequency converter of 3 kW	3751673
EK EVO 6.2900 G-E/G-EF3 prepared for an external frequency converter of 4 kW	3751674
EK EVO 7.3600 G-E prepared for an external frequency converter of 5,5 kW	3751675
EK EVO 7.3600 G-EF3 and EK EVO 7.4500 G-E/G-EF3 prepared for an external frequency converter of 7,5 kW	3751676
EK EVO 7.5800 G-EF3 prepared for an external frequency converter of 11 kW	3756304
EK EVO 7.7000 G-EF3 prepared for an external frequency converter of 15 kW	3756304
EK EVO 8.5800 G-E/G-EU3 prepared for an external frequency converter of 11 kW	3754025
EK EVO 8.7100 G-E/G-EU3 prepared for an external frequency converter of 15 kW	3754026
EK EVO 9.8700 G-E/G-EU3 prepared for an external frequency converter of 18,5 kW	3754027
EK EVO 9.10400 G-E/G-EU3 prepared for an external frequency converter of 22 kW	3754028
EK EVO 9.13000 G-EU2/G-EU3 prepared for an external frequency converter of 37 kW	3756303
EK EVO 6.2400 GL-... prepared for an external frequency converter of 3 kW	3751677
EK EVO 6.2900 GL-... prepared for an external frequency converter of 4 kW	3751678
EK EVO 7.3600 GL-E prepared for an external frequency converter of 5,5 kW	3751679
EK EVO 7.3600 GL-EF3 and EK EVO 7.4500 GL-E/GL-EF3 prepared for an external frequency converter of 7,5 kW	3751680
EK EVO 8.5800 GL-E prepared for an external frequency converter of 11 kW	3755057
EK EVO 8.7100 GL-E and EK EVO 8.5700 GL-EF3 prepared for an external frequency converter of 15 kW	3755058
EK EVO 9.8700 GL-E/GL-EUF prepared for an external frequency converter of 18,5 kW	3755059
EK EVO 9.10400 GL-E/GL-EUF and EK EVO 9.6500 GL-EF3 prepared for an external frequency converter of 22 kW	3755060

MAX GAS PRESSURE SWITCH (mounted on the gas train)

EK EVO 6/7	with Siemens threaded gas trains	3751669
	with Siemens flanged gas trains	3751670
	with Dungs threaded gas trains	3751671
	with Dungs flanged gas trains	3751672
EK EVO 8/9	with Siemens threaded gas trains	3754021
	with Siemens flanged gas trains	3754022
	with Dungs threaded gas trains	3754023
	with Dungs flanged gas trains	3754024

BURNER VARIANTS (options already mounted in factory)
STAR/DELTA MOTOR STARTER

Star/Delta 4,0 G/BT3 for EK EVO 6.2900 G-E, G-EF3, GL-EZ3 and GL-E, GL-EF3	3751650
Star/Delta 5,5 G/BT3 for EK EVO 7.3600 G-E, GL-EZ3 and GL-E	3751651
Star/Delta 7,5 G/BT3 for EK EVO 7.3600 G-EF3, GL-EF3 and EK EVO 7.4500 G-E, G-EF3, GL-EZ3 GL-E, GL-EF3	3751652

PED EQUIPMENT

Equipment of the gas train and the burner body for continuous operation (PED):

- controller and flame sensor approved for continuous operation,
- maximum gas pressure switch on the gas train,
- test burner (to bleed the gas train),
- PED Conformity Declaration.

Note: if required, the antivibrating coupling (to avoid mechanical tension) has to be selected as option

PED for EK EVO 6/7 G-E	with Siemens threaded gas trains	3751653
	with Siemens flanged gas trains	3751654
	with Dungs threaded gas trains	3751655
	with Dungs flanged gas trains	3751656
PED for EK EVO 6/7 G-EF3	with Siemens threaded gas trains	3751665
	with Siemens flanged gas trains	3751666
	with Dungs threaded gas trains	3751667
	with Dungs flanged gas trains	3751668
PED for EK EVO 8/9 G-E and EK EVO 8/9 G-EU3	with Siemens threaded gas trains	3754010
	with Siemens flanged gas trains	3754011
	with Dungs threaded gas trains	3754019
	with Dungs flanged gas trains	3754020
PED for EK EVO 6/7 GL-EZ3 and EK EVO 6/7 GL-E	with Siemens threaded gas trains	3751657
	with Siemens flanged gas trains	3751658
	with Dungs threaded gas trains	3751659
	with Dungs flanged gas trains	3751660
PED for EK EVO 8/9 GL-E	with Siemens threaded gas trains	3755055
	with Siemens flanged gas trains	3755056
	with Dungs threaded gas trains	3755053
	with Dungs flanged gas trains	3755054
PED for EK EVO 6/7 GL-EF3	with Siemens threaded gas trains	3755067
	with Siemens flanged gas trains	3755068
	with Dungs threaded gas trains	3755065
	with Dungs flanged gas trains	3755066
PED for EK EVO 8/9 GL-EU3/GL-EUF	with Siemens threaded gas trains	3755063
	with Siemens flanged gas trains	3755064
	with Dungs threaded gas trains	3755061
	with Dungs flanged gas trains	3755062

BURNER KITS (delivered separately)

O₂ TRIM for BT300, Etamatic and Etamatic OEM

This device optimizes the combustion in order to keep the air excess as much stable as possible irrespective of the changings that can occur during operations, for instance slight calorific value variations, combustion air temperature and pressure. This improves the seasonal efficiency and therefore reduces the fuel consumption.

The kit includes all the fittings for the installation. Main components are:

- control unit with display;
- probe;
- intake pipe to be fixed to the stack (choose the proper length).

The control unit has to be installed close to the probe (max 20 m of cable)

The probe needs a calibration but no reference gas is necessary.

The display shows the O₂ content.

Maximum distance between the control unit and the burner control panel is 500 m.

	Output	Probe length	Code
Kit for O₂ trim (LT3 + LS2) - Flue temp max 300 °C - display for O₂ visualization (Note: for models equipped with BT3xx this kit needs a LCM module installed in the burner control panel)	1 x 4-20 mA	150 mm	3757433
	1 x 4-20 mA	300 mm	3757137
	1 x 4-20 mA	450 mm	3757138

O₂ TRIM with CO measure for BT300, Etamatic and Etamatic OEM

This device optimizes the combustion in order to keep the air excess as low as possible in order to maximize the seasonal efficiency and therefore minimize the fuel consumption.

In addition to the features of the O₂ trim only, this kit reduces the air excess to its minimum because this system continuously measures the CO content in the flue: should the air excess be reduced too much, the CO raises and the system reacts by increasing the air excess in order to keep firing in safe conditions.

The kit includes all the fittings for the installation. Main components are:

- control unit with display;
- probe;
- intake pipe to be fixed to the stack (choose the proper length).

The control unit has to be installed close to the probe (max 20 m of cable).

The probe needs a calibration but no reference gas is necessary.

The display shows the O₂ content.

Maximum distance between the control unit and the burner control panel is 500 m.

Note: this system is not suitable for GL-EUF and L-EUF burners

	Output	Probe length	Code
Kit for O₂ trim and CO control (LT3-F + KS1D) - Flue temp max 300 °C (Note: for models equipped with BT3xx this kit needs a LCM module installed in the burner control panel)	None	150 mm	3758001
	None	300 mm	3755046
	None	450 mm	3756533
	4 x 0/4-20mA	300 mm	3754549
	4 x 0/4-20mA	450 mm	3754550
	4 x 0/4-20mA & 4 x digital	300 mm	3754551
	4 x 0/4-20mA & 4 x digital	450 mm	3754552

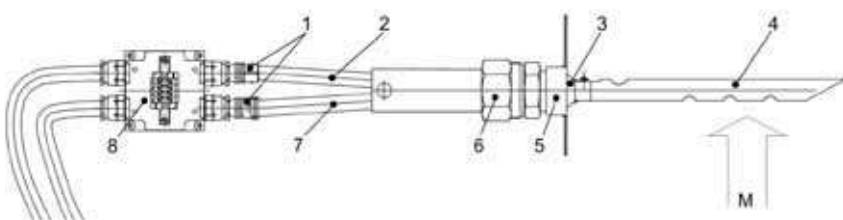

- M - measuring gas 300°C max
- 1 - plug
- 2 - probe signal
- 3 - Lambda Probe
- 4 - gas extraction device (GED)
- 5 - half-collar R1 1/4
- 6 - probe installation fitting (PIF)
- 7 - probe heater
- 8 - probe connection box (PCB)

BURNER KITS (delivered separately)
REMOTE SOFTWARE

Kit to connect a PC laptop to the BT300 for its parametrization	LSA100 + USB/CAN + CD-Rom	3751130
---	---------------------------	---------

COMMUNICATION MODULES

Module for external installation Note: LCM module is required	ModBus/BT3	3754456
	ProfiBus/BT3	3752986
	Ethernet/BT3	on request

POWER REGULATOR

Power regulator RWF55 stand-alone and kit wiring	3753358
--	---------

PROBES

Immersion probes	130°C + pocket tube	3750070
	Pt 100 - 400°C (160 mm)	1758574269
	Pt 100 - 480°C (250 mm)	3751009
Pressure probes	0...1,6 bar	3752217
	0...2,5 bar	1758713722
	0...6 bar	1758640660
	0...10 bar	1758577280
	0...16 bar	1758577291
	0...25 bar	3751015

EXTERNAL AIR INLET CONNECTION KIT

Connection for external air channel for EK EVO 6 and EK EVO 7	3752987
Connection for external air channel for EK EVO 8 and EK EVO 9	3754031

ACOUSTIC SHROUDS

See page 215 for all sizes

SPECIAL CONFIGURATIONS (on request)

- Equipment according EN746-2
- Permanent ventilation
- 60 Hz versions
- Remote display (BT3xx)
- Separate switch box / terminal strip version (Etamatic OEM)
- LPG firing
- Hinge flange
- "Burner ON" feedback signal

Other special requests can be submitted to your Sales Reference for feasibility evaluation

Monoblock burners from 250 to 11200 kW

Gas, light oil and dual fuel



Design: smooth and integral

The original design of NEXTRON® range is the result of a successful integration between burner and ELCO technologies. NEXTRON® burners are able to perfectly integrate themselves in any installation and professionals will appreciate the innovative construction that ease maintenance.

Unique Low NOx performance

Developed and improved by ELCO R&D department, the Free Flame technology is a unique combustion process. This ELCO technology is capable to reach the NOx levels required by the most severe standards for all types of combustion chambers, whether they are 3-pass or reverse pass boilers.

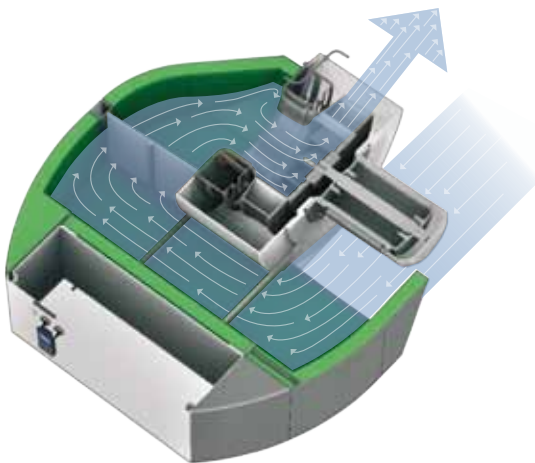

High acoustic comfort

The NEXTRON® burner range offers a high acoustic comfort thanks to the Low Noise System. The unique air intake channel is carefully designed to achieve an acoustic level significantly lower than 80 dB(A) up to 10 MW. This integrated and patented system on all NEXTRON® burners is definitely a good replacement of the traditional bulky sound proofing box.

Built-in and modular switch cabinet

All the NEXTRON® burners feature integrated switch cabinet, the ISC System, with modular concept for control devices and accessories:

- adjusting and safety control box
- EMC protected power circuit of fan motor
- display with command keyboard in front of the panel

The ISC System houses options and accessories, such as the power regulator and the frequency inverter Variatron, and customizes each burner according to the installation needs.



MAIN TECHNICAL FEATURES

- Two stage progressive/modulating forced draught burner.
- Fuels:
 - natural gas, Hi = 6,99 ... 11,39 kWh/Nm³
 - LPG, Hi = 25,89 kWh/Nm³
 - light oil, viscosity 6 mm²/s at 20°C, Hi = 11,86 kWh/kg
- Combustion technology:
 - Low NOx class 2 (≤ 120 mg/kWh) and class 3 (≤ 80 mg/kWh) in gas operation according to EN676
 - Low NOx class 2 (≤ 185 mg/kWh) and class 3 (≤ 120 mg/kWh) in light oil operation according to EN267
- Integrated switch cabinet (ISC System) with modular concept complete for an easy installation with:
 - BT300 control box (MDE2 System and display);
 - fan motor direct start-up;
 - enumerated connection terminals;
 - power regulator (option);
 - speed controller Variatron (option);
 - O₂ control (option);
 - Bus interface (option)
- Innovative design allowing easy access to burner components for fast start-up and reduced maintenance time and space
- Three flame tube lengths available
- Secured burner head adjustments during maintenance (RTC System)
- Unique air intake channel design (patented) to reduce acoustic levels (Low Noise System)
- Closing of the air damper on burner shut-down
- Multiple gas train matching according to the inlet gas pressure
- Gas train factory assembled and tested for tightness and electrical security
- Products are in compliance with EN676 and EN267 European standards and with the following directives:
 - 2014/35/UE Low Voltage Directive
 - 2014/30/UE EMC Directive
 - 2016/426/UE Gas Appliances Regulation
 - 2006/42/EC Machinery Directive
 - 2011/65/EU RoHS2 Directive

RANGE OVERVIEW

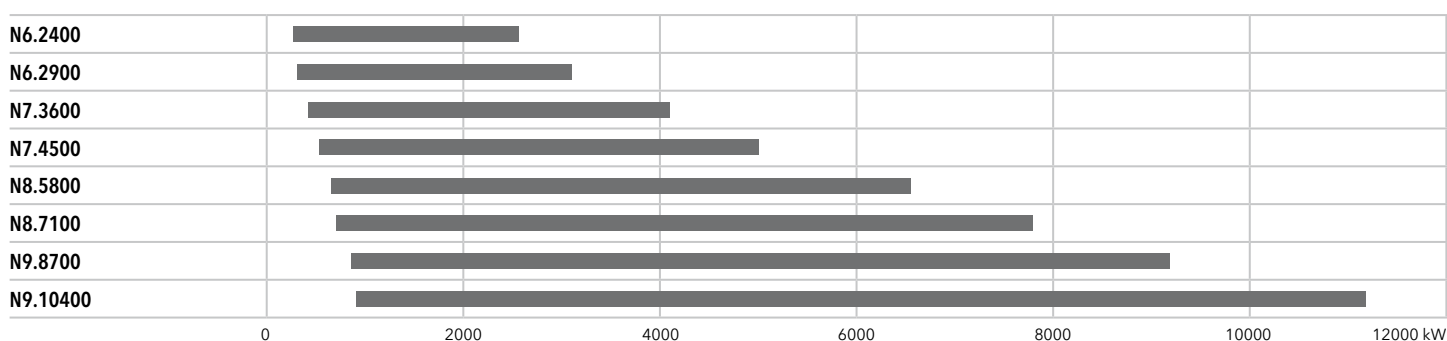

N6 G-E, N7 G-E

390 ... 5000 kW

2 stage progressive/modulating electronic

- **Fuels:** natural gas, Hi = 6,99 ... 11,39 kWh/Nm³;
LPG, Hi = 25,89 kWh/Nm³
- **Emission class:** Low NO_x class 2 (≤120 mg/kWh) according to EN676
- **Protection level:** IP 41



TECHNICAL DATA

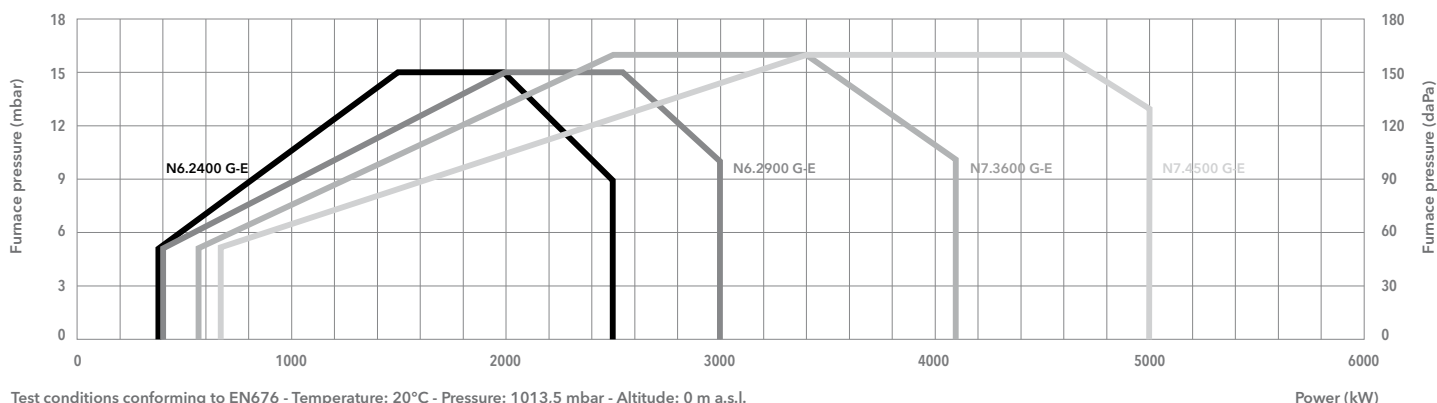

Test conditions conforming to EN676 - Temperature: 20°C - Pressure: 1013,5 mbar - Altitude: 0 m a.s.l.

	N6.2400 G-E	N6.2900 G-E	N7.3600 G-E	N7.4500 G-E
Operating range	390 - 2500 kW	400 - 3000 kW	580 - 4100 kW	680 - 5000 kW
Gas pressure	50 - 500 mbar (50 - 360 mbar for d452 and d453 gas train)		50 - 500 mbar (50 - 360 mbar for d452 and d453 gas train)	
Gas connection	DN65	DN65	DN65	DN65
Control box / flame detector	BT300 / Ionisation	BT300 / Ionisation	BT300 / Ionisation	BT300 / Ionisation
Auxiliary voltage	1NPE AC 230 V - 50 Hz TN-S	1NPE AC 230 V - 50 Hz TN-S	1NPE AC 230 V - 50 Hz TN-S	1NPE AC 230 V - 50 Hz TN-S
Power supply	3PE AC 400 V - 50 Hz	3PE AC 400 V - 50 Hz	3PE AC 400 V - 50 Hz	3PE AC 400 V - 50 Hz
Fan motor	50 Hz - 3 kW	50 Hz - 4 kW	50 Hz - 5,5 kW	50 Hz - 7,5 kW
Acoustic level	<70 dB(A)	<71 dB(A)	<74 dB(A)	<75 dB(A)
CE certificate	0085CL0215	0085CL0215	0085CL0215	0085CL0215
Complete burner codes	on request	on request	on request	on request

GAS TRAINS

DUNGS

Model	Code
GT-d452-1"1/2 (*)	3750510
GT-d453-2" (*)	3750511
GT-d454-65	3750512
GT-d455-80	3750513
GT-d456-100	3750514

*: integrated filter

SIEMENS

Model	Code
GT-s451-1"1/2	3750525
GT-s452-2"	3750526
GT-s453-65	3750527
GT-s454-80	3750528
GT-s455-100	3750529
GT-s456-125	3750530

FILTERS

Model	Code
FG-Rp1"1/2	3757199
FG-Rp2"	3757200
FG-DN65	3757198
FG-DN80	3757201
FG-DN100	3757195
FG-DN125	3757209

 **Pressure drops graphs:** see following pages
Dimensions of gas trains and gas filters: see pag. 206



DIMENSIONS (mm)

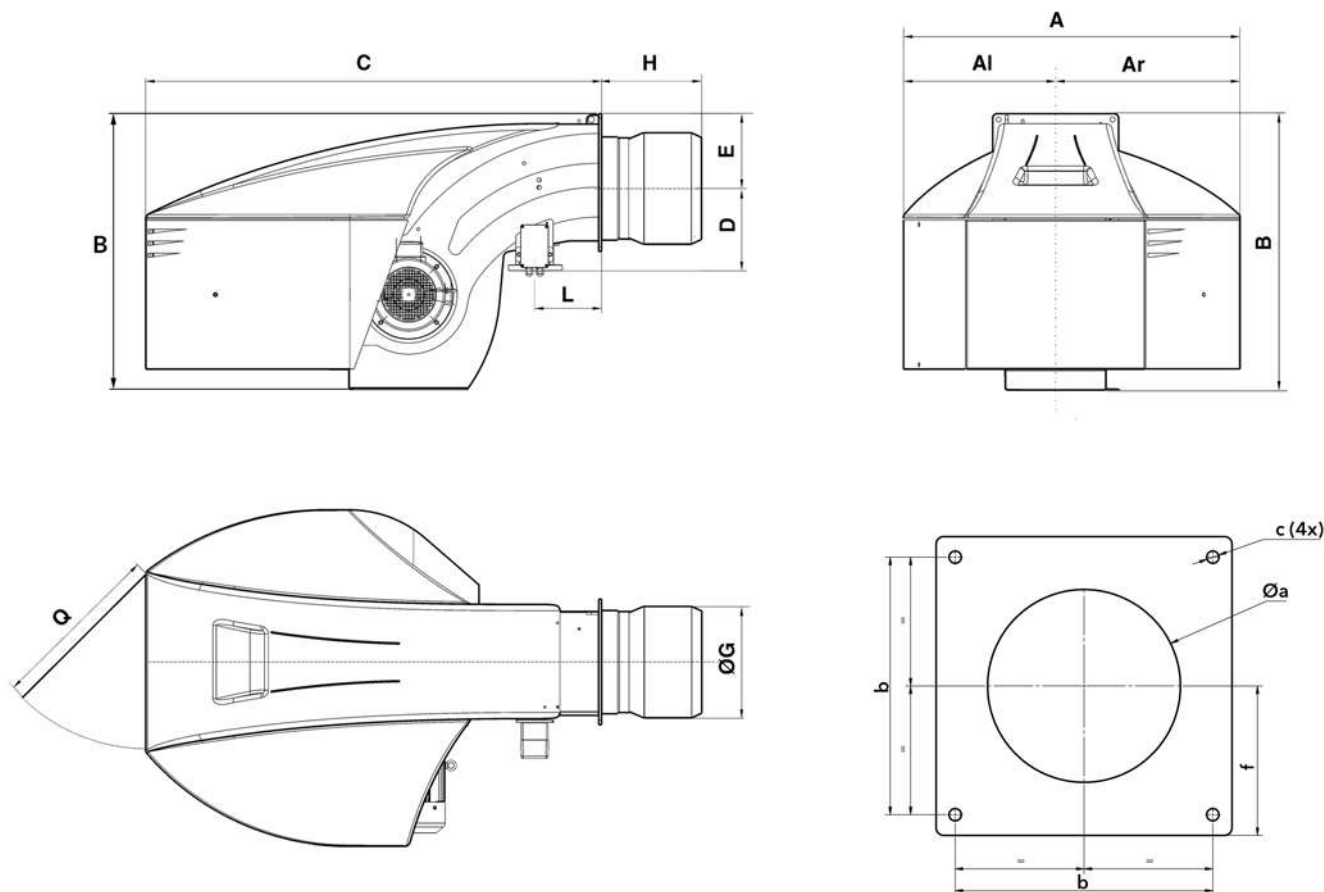

Model	A	Al	Ar	B	C	D	E	ØG	H			L	Q	Øa	b	c	f
									KN	KM	KL						
N6	990	479	510	837	1361	245	225	320	330	450	570	215	600	330-340	340	M16	200
N7	1128	511	618	961	1529	276	255	370	375	505	635	225	600	380-400	400	M16	235

PACKAGING

The burner is delivered on a pallet in 2 packages containing:

- burner body with mounted combustion head, boiler fixing accessories and technical documentation;
- gas train and filter.

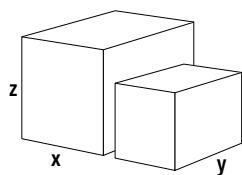

Models	Dimensions (mm)			Gross weight (kg)	
	X	Y	Z		
N6.2400 G-E	KN	1691	990	837	280
	KM	1811	990	837	280
	KL	1931	990	837	280
N6.2900 G-E	KN	1691	990	837	290
	KM	1811	990	837	290
	KL	1931	990	837	290
N7.3600 G-E	KN	1904	1128	961	320
	KM	2034	1128	961	320
	KL	2164	1128	961	320
N7.4500 G-E	KN	2049	1128	961	330
	KM	2179	1128	961	330
	KL	2309	1128	961	330

PRESSURE LOSSES (BURNER HEAD + GAS TRAIN)

N6.2400 G-E

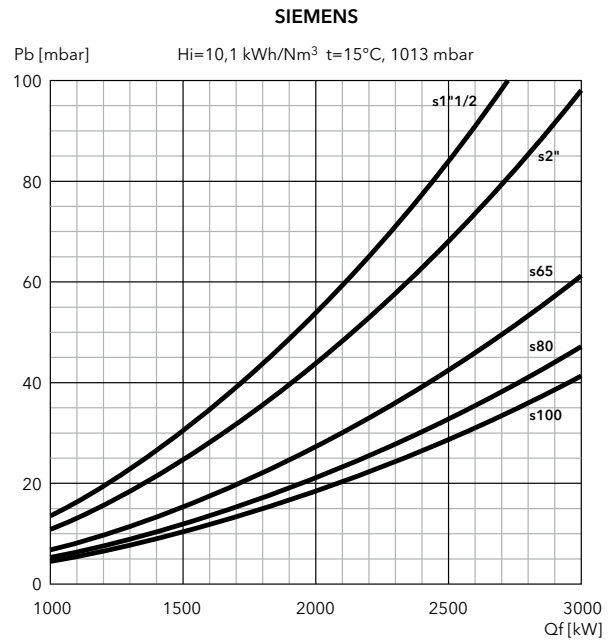
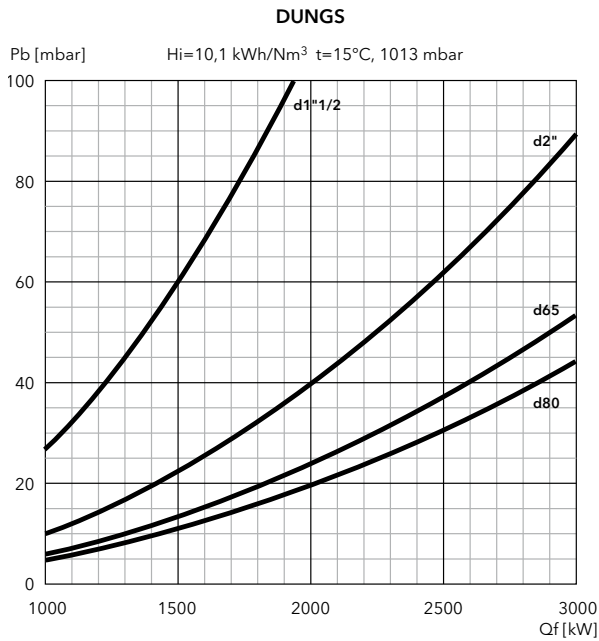

N6.2900 G-E

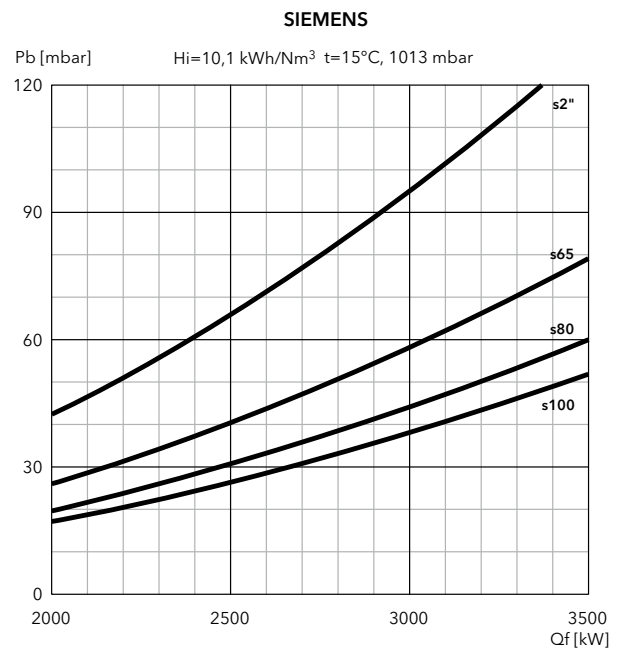
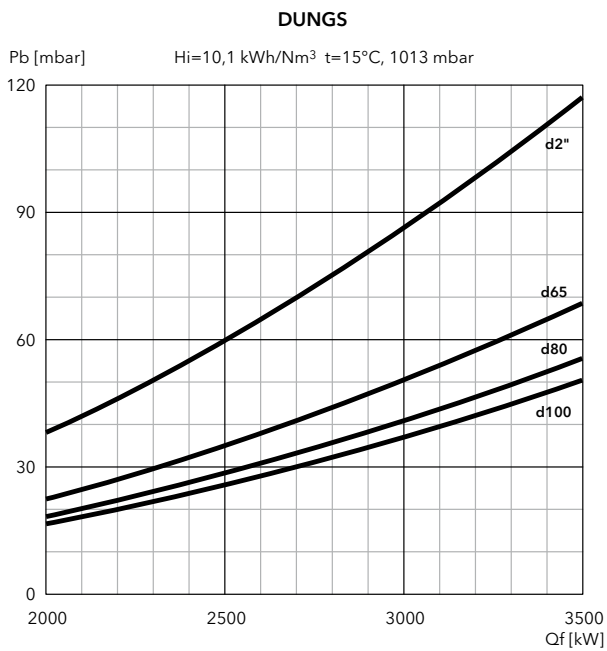

FILTERS

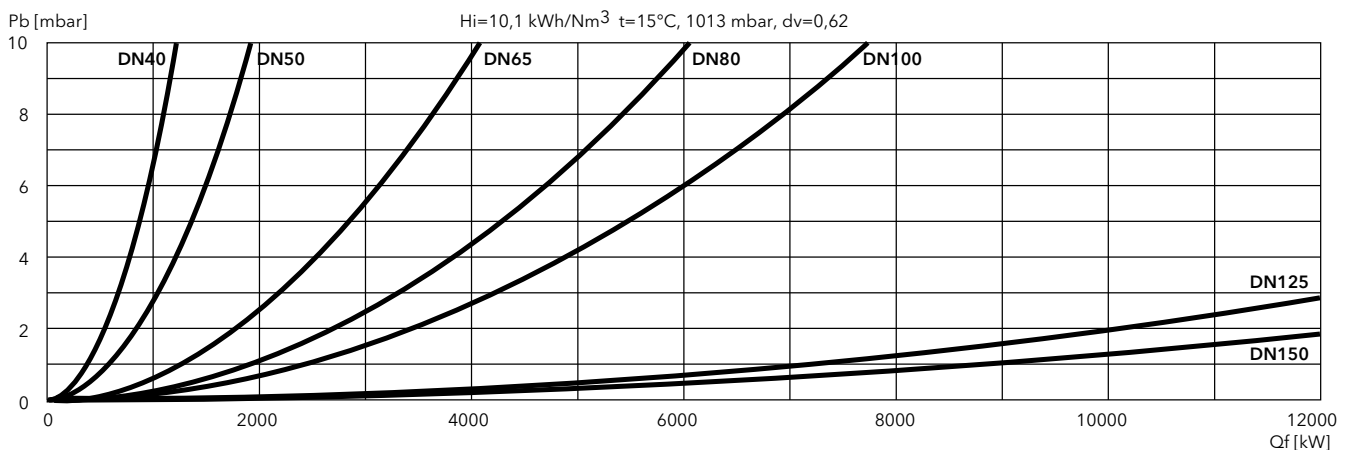

PRESSURE LOSSES (BURNER HEAD + GAS TRAIN)

N7.3600 G-E

DUNGS

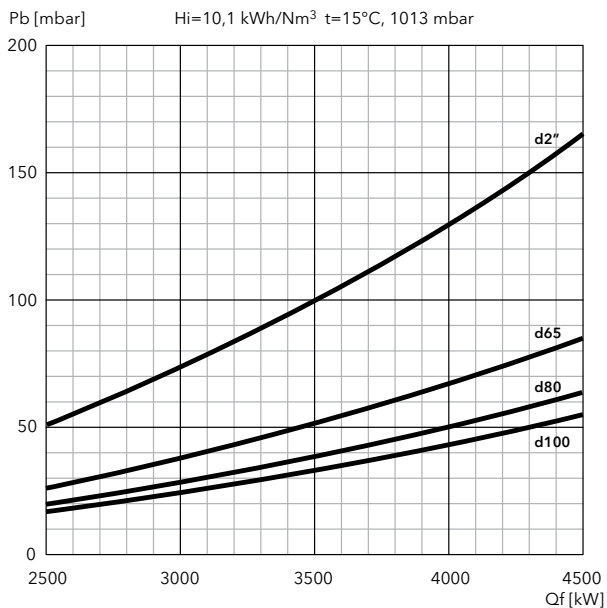

SIEMENS

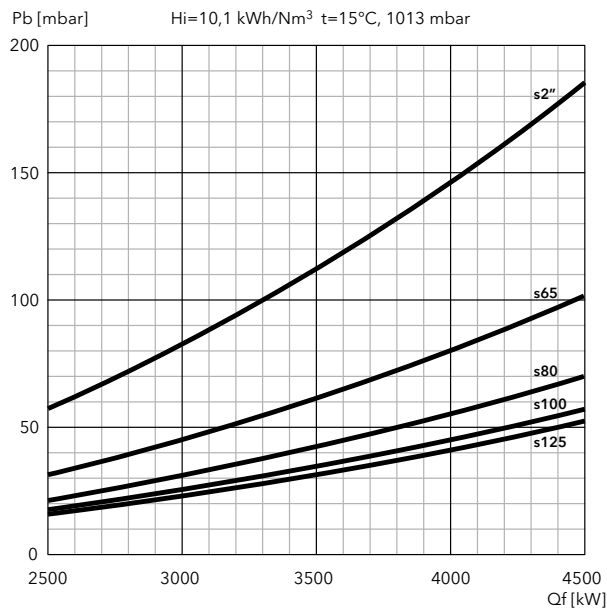

N7.4500 G-E

DUNGS

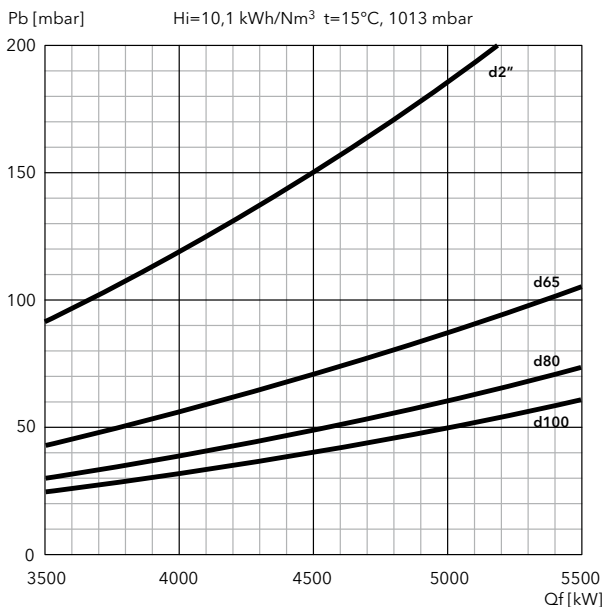

SIEMENS

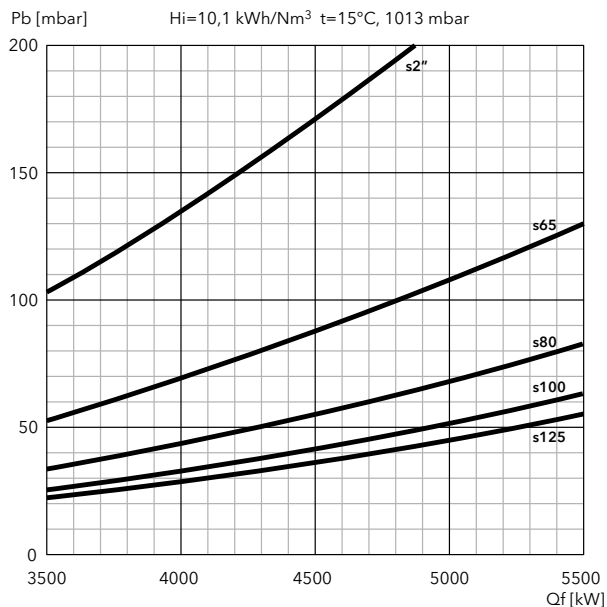

FILTERS

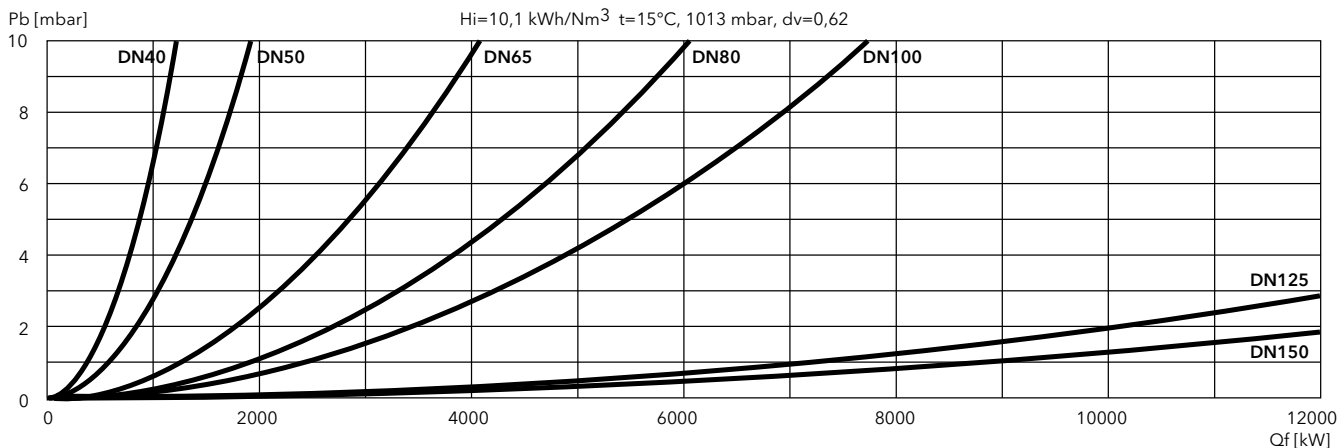

N8 G-E, N9 G-E

740 ... 11200 kW

2 stage progressive/modulating electronic

- **Fuels:** natural gas, Hi = 6,99 ... 11,39 kWh/Nm³;
LPG, Hi = 25,89 kWh/Nm³
- **Emission class:** Low NOx class 2 (≤120 mg/kWh) according to EN676
- **Modulating ratio:** 1:10
- **Protection level:** IP 41



TECHNICAL DATA

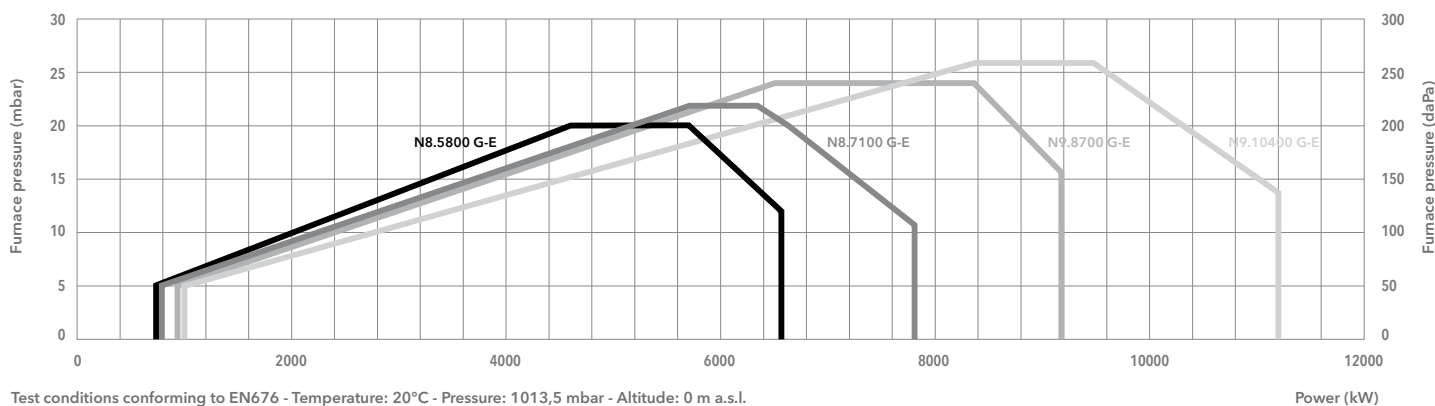

Test conditions conforming to EN676 - Temperature: 20°C - Pressure: 1013,5 mbar - Altitude: 0 m a.s.l.

	N8.5800 G-E	N8.7100 G-E	N9.8700 G-E	N9.10400 G-E
Operating range	740 - 6570 kW	800 - 7800 kW	880 - 9200 kW	960 - 11200 kW
Gas pressure	60 - 500 mbar (60 - 360 mbar for d457 gas train)		70 - 500 mbar (70 - 360 mbar for d457 gas train)	
Gas connection	DN100	DN100	DN100	DN100
Control box / flame detector	BT300 / Ionisation	BT300 / Ionisation	BT300 / Ionisation	BT300 / Ionisation
Auxiliary voltage	1NPE AC 230 V - 50 Hz TN-S	1NPE AC 230 V - 50 Hz TN-S	1NPE AC 230 V - 50 Hz TN-S	1NPE AC 230 V - 50 Hz TN-S
Power supply	3PE AC 400 V - 50 Hz	3PE AC 400 V - 50 Hz	3PE AC 400 V - 50 Hz	3PE AC 400 V - 50 Hz
Fan motor	50 Hz - 11 kW	50 Hz - 15 kW	50 Hz - 18,5 kW	50 Hz - 22 kW
Acoustic level	<78 dB(A)	<78 dB(A)	<80 dB(A)	<81 dB(A)
CE certificate	0085CL0215	0085CL0215	0085CL0215	0085CL0215
Complete burner codes	on request	on request	on request	on request

GAS TRAINS

DUNGS

Model	Code
GT-d457-2" (*)	3750515
GT-d458-65	3750516
GT-d459-80	3750517
GT-d460-100	3750518

*: integrated filter

SIEMENS

Model	Code
GT-s457-2"	3750537
GT-s458-65	3750538
GT-s459-80	3750539
GT-s460-100	3750540
GT-s461-125	3750541

FILTERS

Model	Code
FG-Rp2"	3757200
FG-DN65	3757198
FG-DN80	3757201
FG-DN100	3757195
FG-DN125	3757209

Pressure drops graphs: see following pages
Dimensions of gas trains and gas filters: see pag. 207



DIMENSIONS (mm)

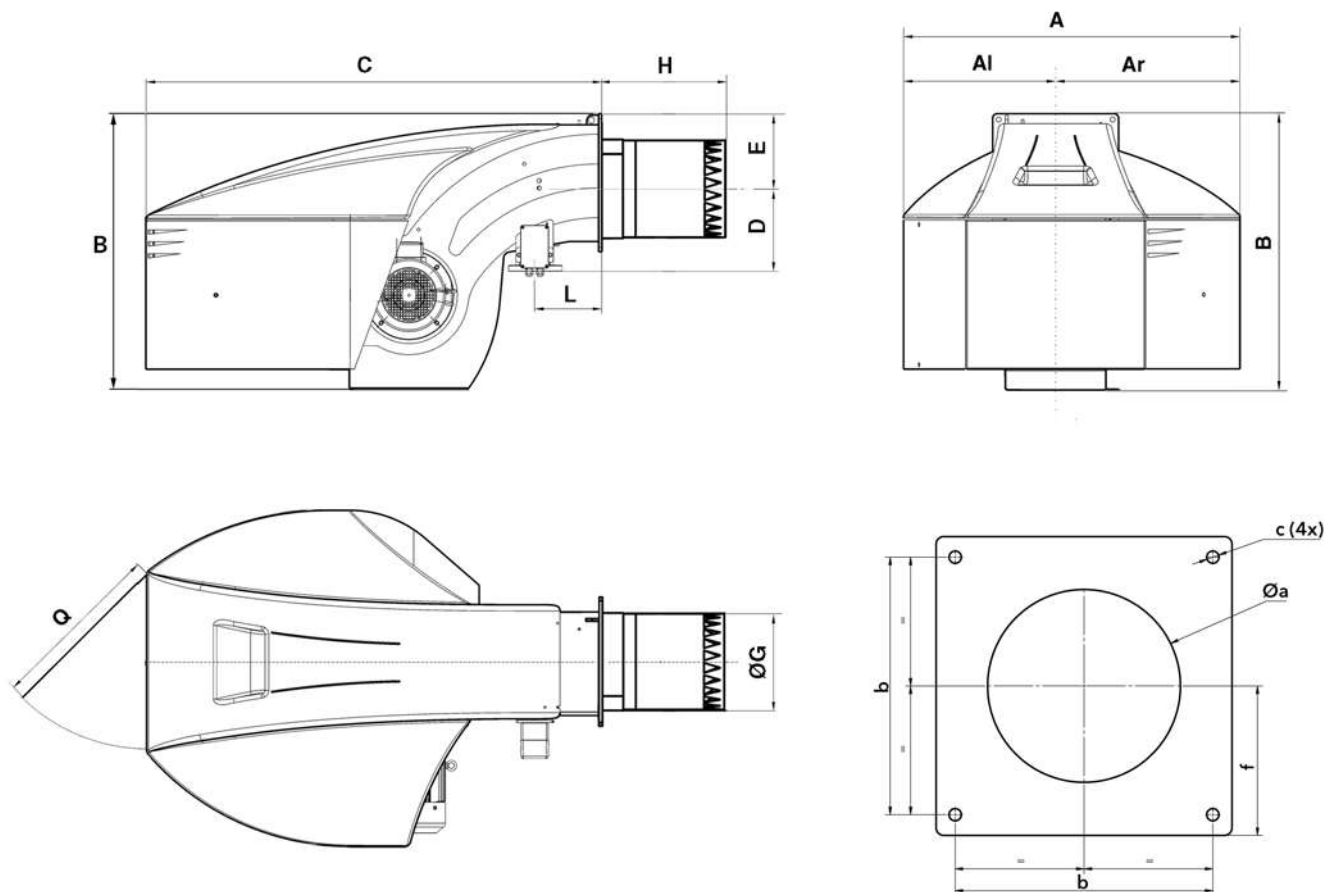

Model	A	Al	Ar	B	C	D	E	ØG	H			L	Q	Øa	b	c	f
									KN	KM	KL						
N8	1414	669	745	1231	1930	344	293	369	500	640	780	230	800	390-410	505	M20	293
N9	1414	669	745	1291	1928	369	293	431,5	550	700	850	230	800	460-480	505	M20	293

PACKAGING

The burner is delivered on a pallet in 2 packages containing:

- burner body with mounted combustion head, boiler fixing accessories and technical documentation;
- gas train and filter.

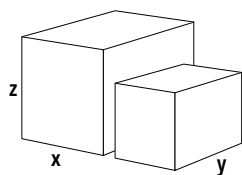

Models		Dimensions (mm)			Gross weight (kg)
		X	Y	Z	
N8.5800 G-E	KN	2430	1414	1231	527
	KM	2570	1414	1231	527
	KL	2710	1414	1231	527
N8.7100 G-E	KN	2430	1414	1231	535
	KM	2570	1414	1231	535
	KL	2710	1414	1231	535
N9.8700 G-E	KN	2430	1414	1231	527
	KM	2570	1414	1231	527
	KL	2710	1414	1231	527
N9.10400 G-E	KN	2430	1414	1231	535
	KM	2570	1414	1231	535
	KL	2710	1414	1231	535

PRESSURE LOSSES (BURNER HEAD + GAS TRAIN)

N8.5800 G-E

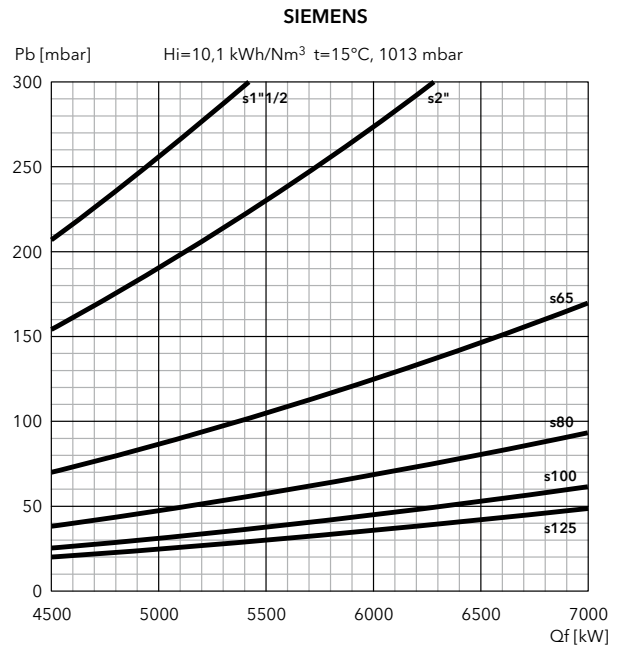
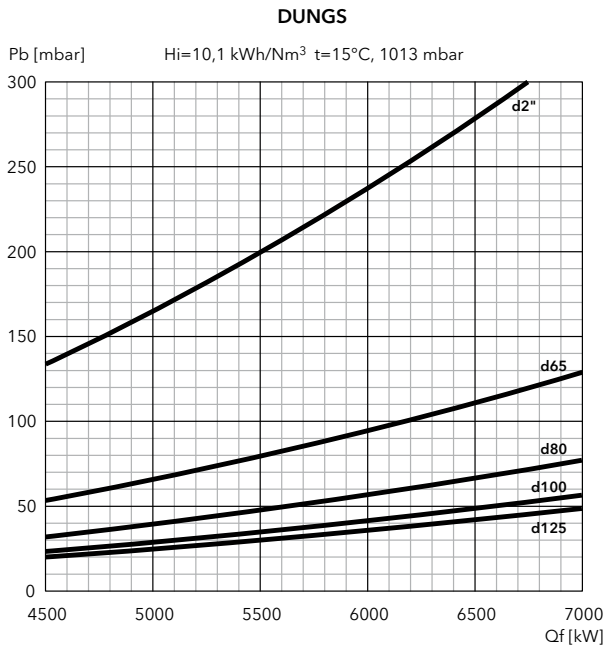

N8.7100 G-E

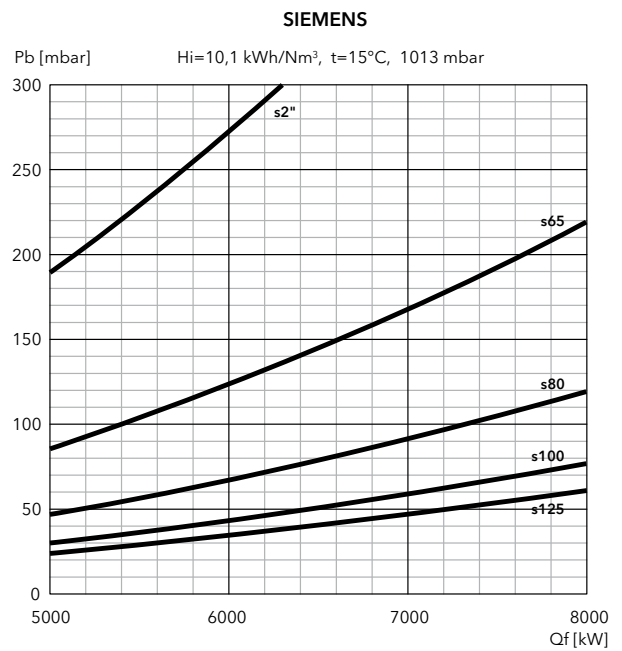
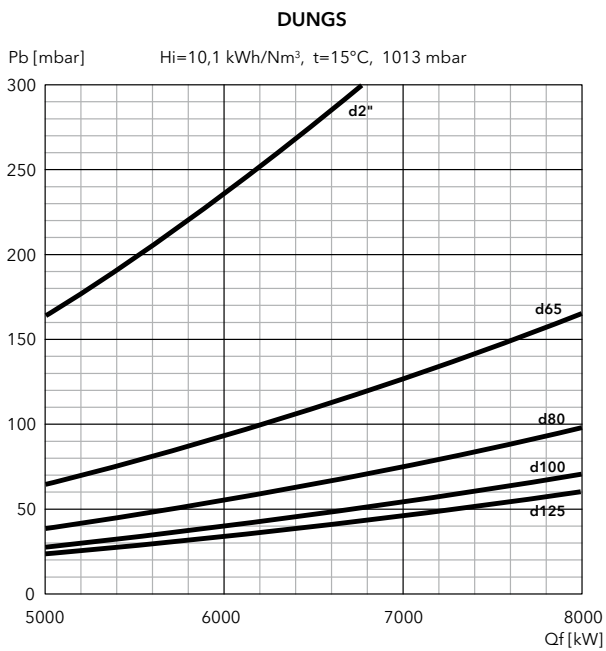

FILTERS

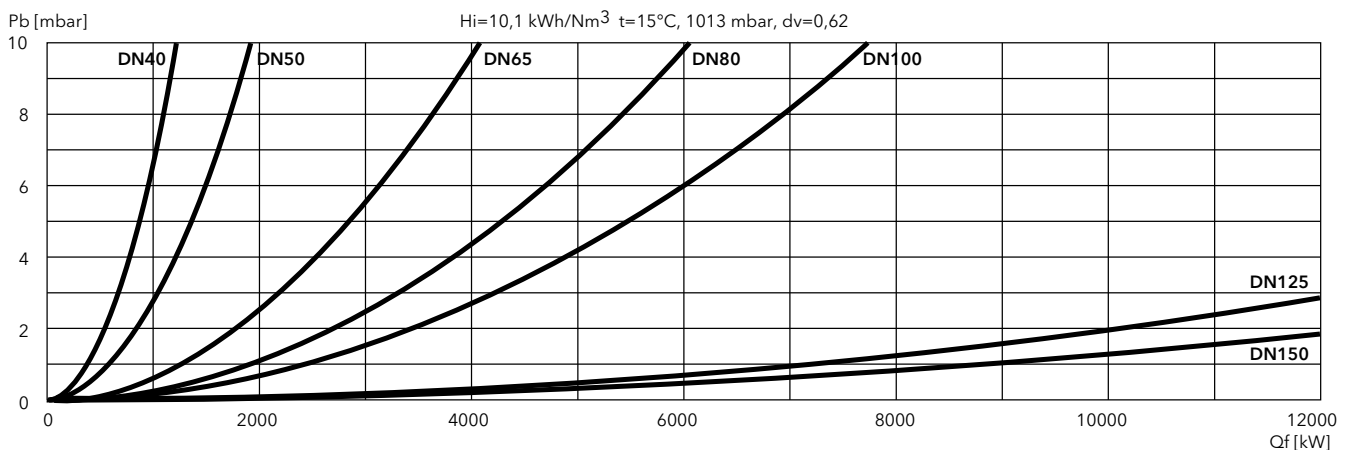

PRESSURE LOSSES (BURNER HEAD + GAS TRAIN)

N9.8700 G-E

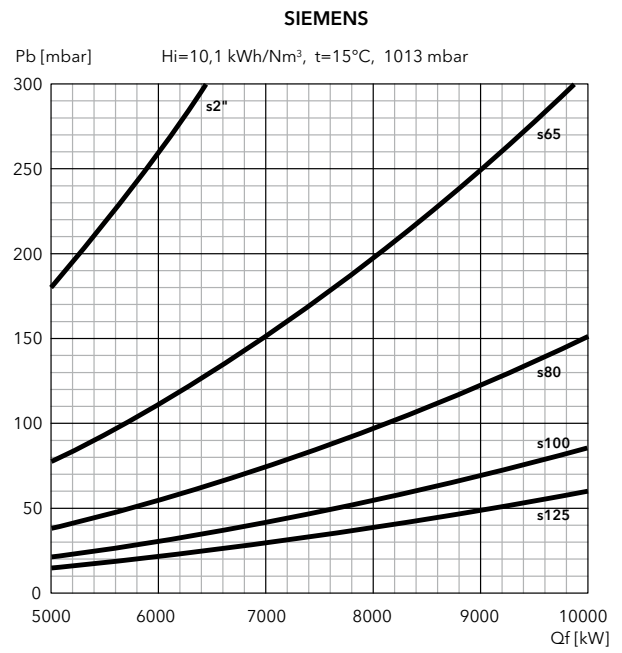
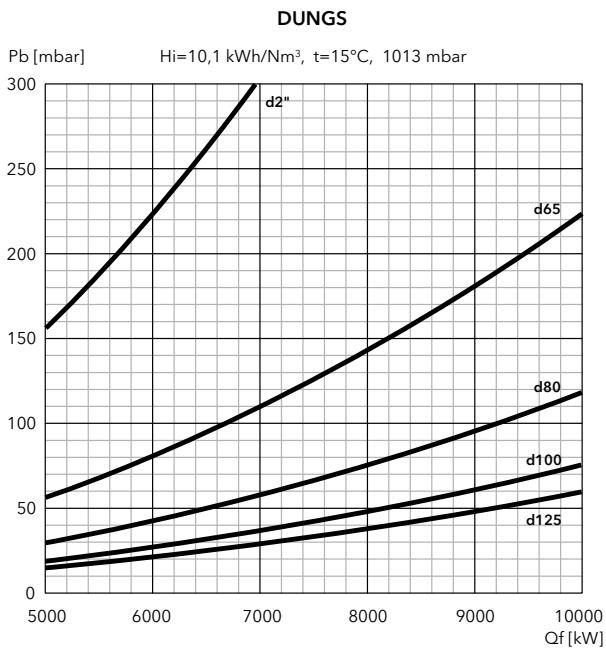

N9.10400 G-E

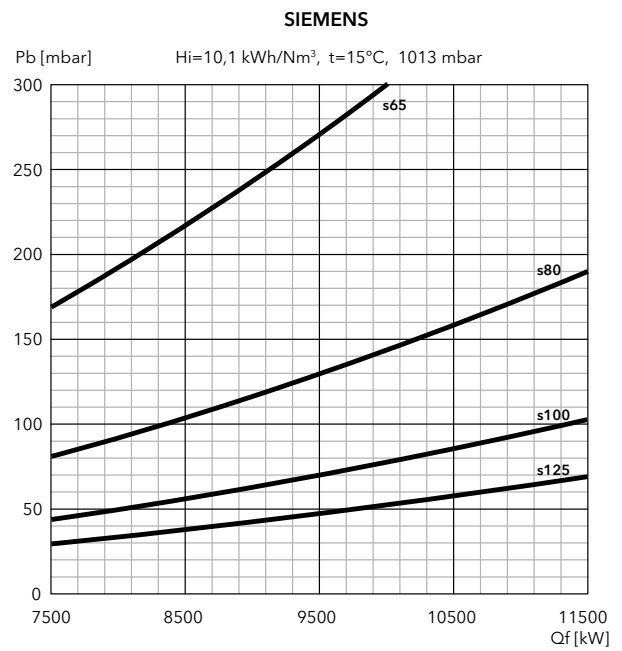
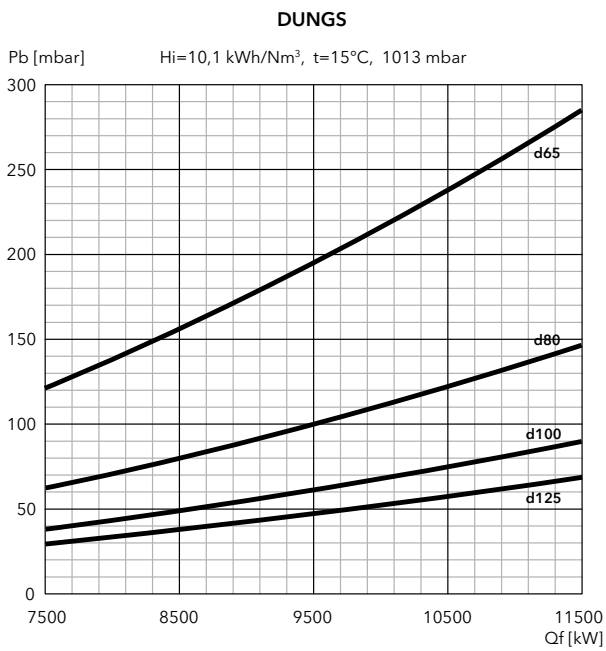

FILTERS

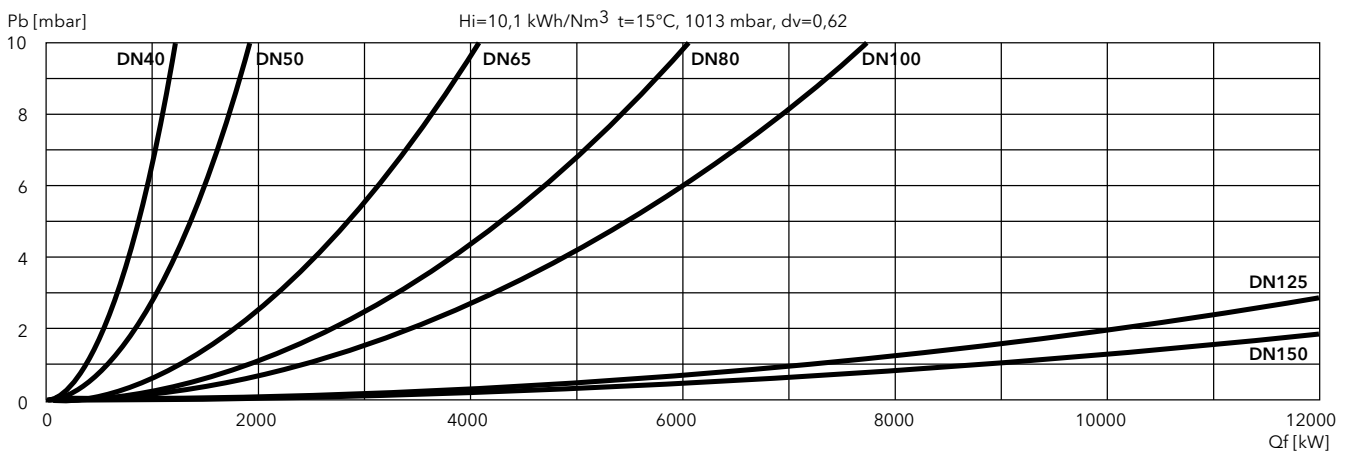

N6 G-EF3, N7 G-EF3

340 ... 4200 kW

2 stage progressive/modulating electronic (Low NOx class 3)

- **Fuels:** natural gas, Hi = 6,99 ... 11,39 kWh/Nm³;
LPG, Hi = 25,89 kWh/Nm³
- **Emission class:** Low NOx class 3 (≤80 mg/kWh) according to EN676
- **Protection level:** IP 41



TECHNICAL DATA

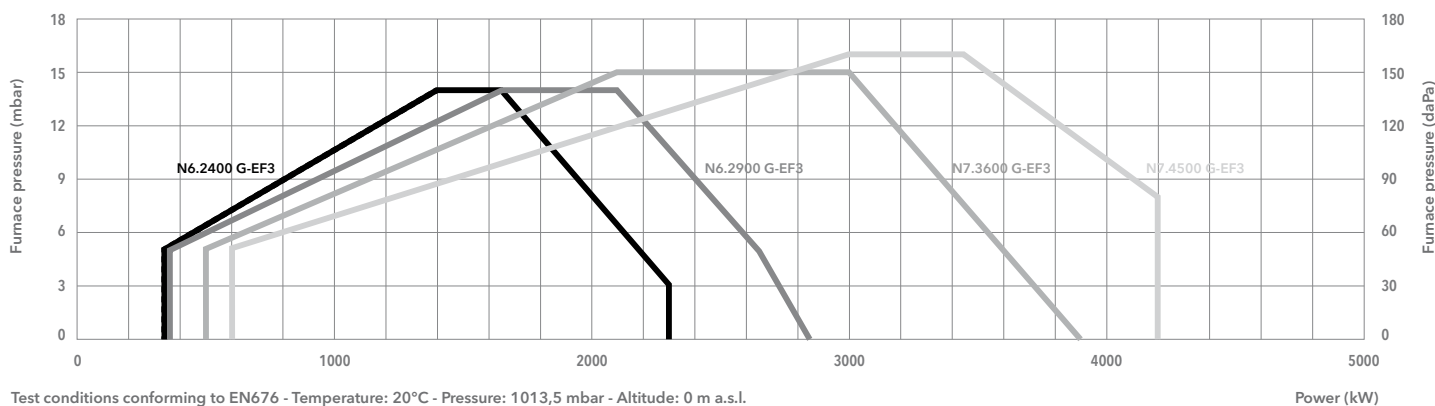

Test conditions conforming to EN676 - Temperature: 20°C - Pressure: 1013,5 mbar - Altitude: 0 m a.s.l.

	N6.2400 G-EF3	N6.2900 G-EF3	N7.3600 G-EF3	N7.4500 G-EF3
Operating range	340 - 2300 kW	360 - 2850 kW	500 - 3900 kW	600 - 4200 kW
Gas pressure	50 - 500 mbar (50 - 360 mbar for d452 and d453 gas train)		50 - 500 mbar (50 - 360 mbar for d452 and d453 gas train)	
Gas connection	DN65	DN65	DN65	DN65
Control box / flame detector	BT300 / QRA2	BT300 / QRA2	BT300 / QRA2	BT300 / QRA2
Auxiliary voltage	1NPE AC 230 V - 50 Hz TN-S	1NPE AC 230 V - 50 Hz TN-S	1NPE AC 230 V - 50 Hz TN-S	1NPE AC 230 V - 50 Hz TN-S
Power supply	3PE AC 400 V - 50 Hz	3PE AC 400 V - 50 Hz	3PE AC 400 V - 50 Hz	3PE AC 400 V - 50 Hz
Fan motor	50 Hz - 3 kW	50 Hz - 4 kW	50 Hz - 7,5 kW	50 Hz - 7,5 kW
Acoustic level	<70 dB(A)	<71 dB(A)	<74 dB(A)	<75 dB(A)
CE certificate	0085CL0215	0085CL0215	0085CL0215	0085CL0215
Complete burner codes	on request	on request	on request	on request

GAS TRAINS

DUNGS

Model	Code
GT-d452-1"1/2 (*)	3750510
GT-d453-2" (*)	3750511
GT-d454-65	3750512
GT-d455-80	3750513
GT-d456-100	3750514

*: integrated filter

SIEMENS

Model	Code
GT-s451-1"1/2	3750525
GT-s452-2"	3750526
GT-s453-65	3750527
GT-s454-80	3750528
GT-s455-100	3750529
GT-s456-125	3750530

FILTERS

Model	Code
FG-Rp1"1/2	3757199
FG-Rp2"	3757200
FG-DN65	3757198
FG-DN80	3757201
FG-DN100	3757195
FG-DN125	3757209

Pressure drops graphs: see following pages
Dimensions of gas trains and gas filters: see pag. 206



DIMENSIONS (mm)

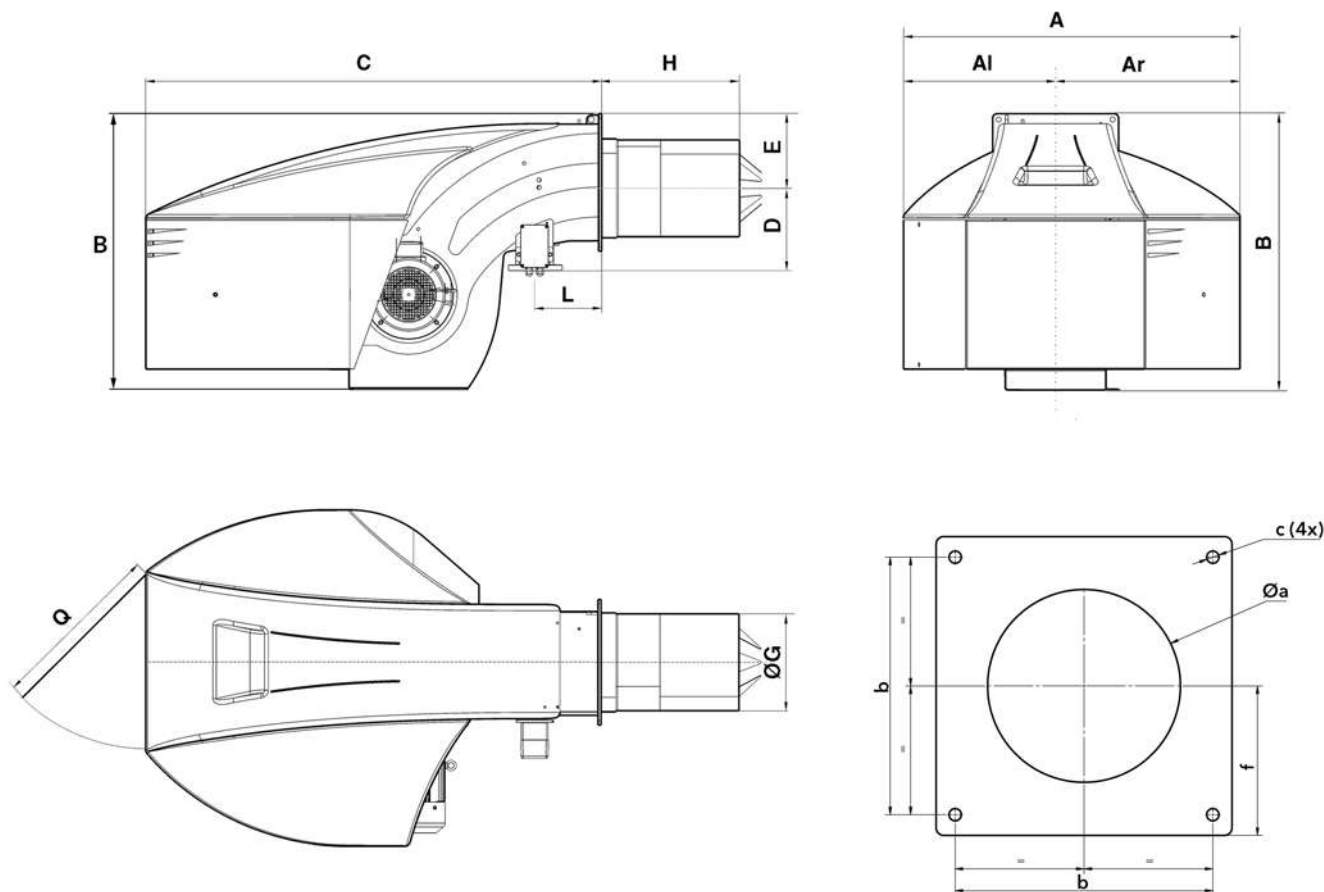

Model	A	Al	Ar	B	C	D	E	ØG	H			L	Q	Øa	b	c	f
									KN	KM	KL						
N6	990	479	510	837	1361	245	225	264	400	520	640	215	600	330-340	340	M16	200
N7	1128	511	618	961	1529	276	255	326	420	550	680	225	600	380-400	400	M16	235

PACKAGING

The burner is delivered on a pallet in 2 packages containing:

- burner body with mounted combustion head, boiler fixing accessories and technical documentation;
- gas train and filter.

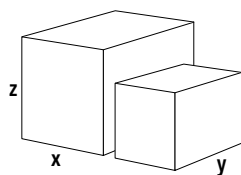

Models		Dimensions (mm)			Gross weight (kg)
		X	Y	Z	
N6.2400 G-EF3	KN	1861	990	837	280
	KM	1981	990	837	280
	KL	2101	990	837	280
N6.2900 G-EF3	KN	1861	990	837	290
	KM	1981	990	837	290
	KL	2101	990	837	290
N7.3600 G-EF3	KN	2049	1128	961	320
	KM	2179	1128	961	320
	KL	2309	1128	961	320
N7.4500 G-EF3	KN	2049	1128	961	330
	KM	2179	1128	961	330
	KL	2309	1128	961	330

PRESSURE LOSSES (BURNER HEAD + GAS TRAIN)

N6.2400 G-EF3

DUNGS

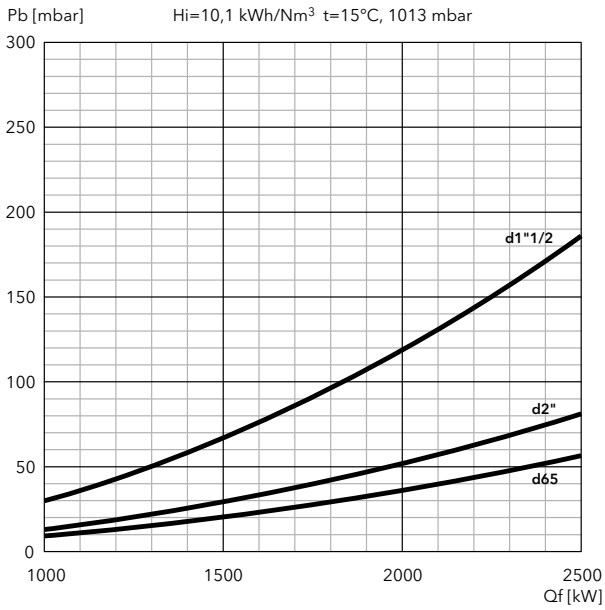

SIEMENS

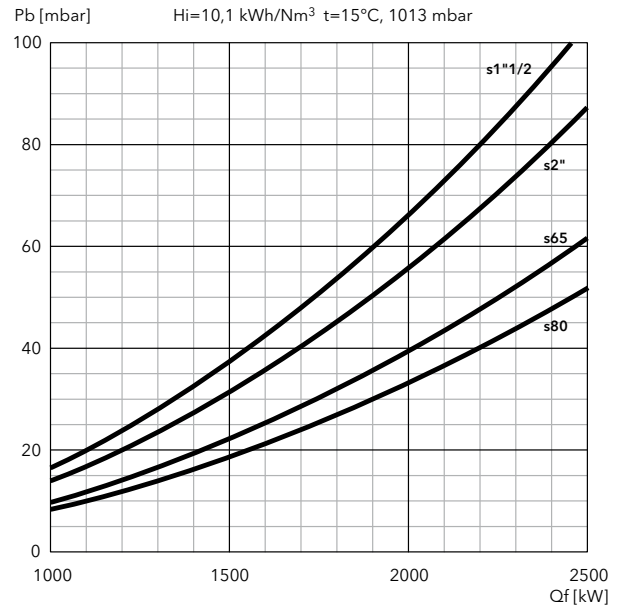

N6.2900 G-EF3

DUNGS

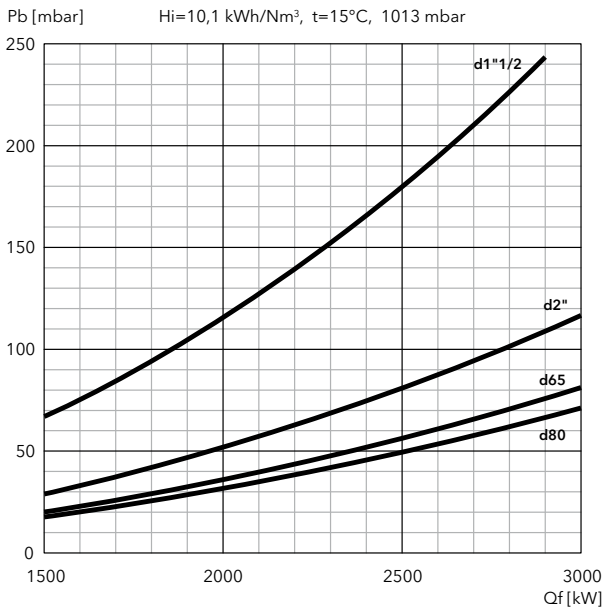

SIEMENS

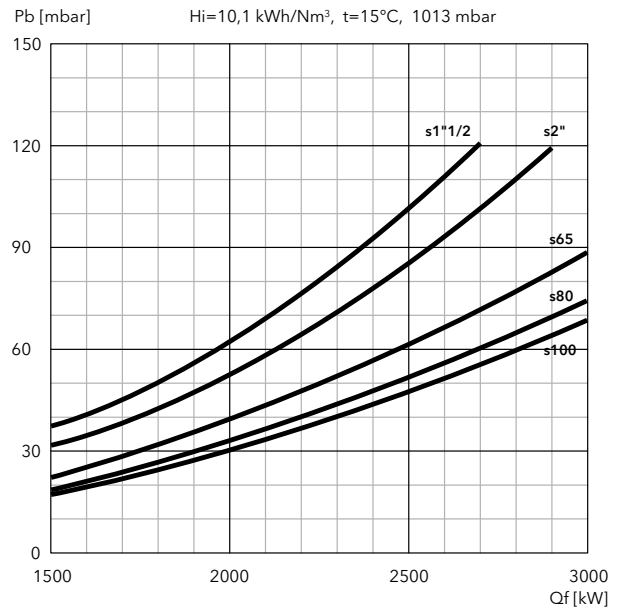

FILTERS

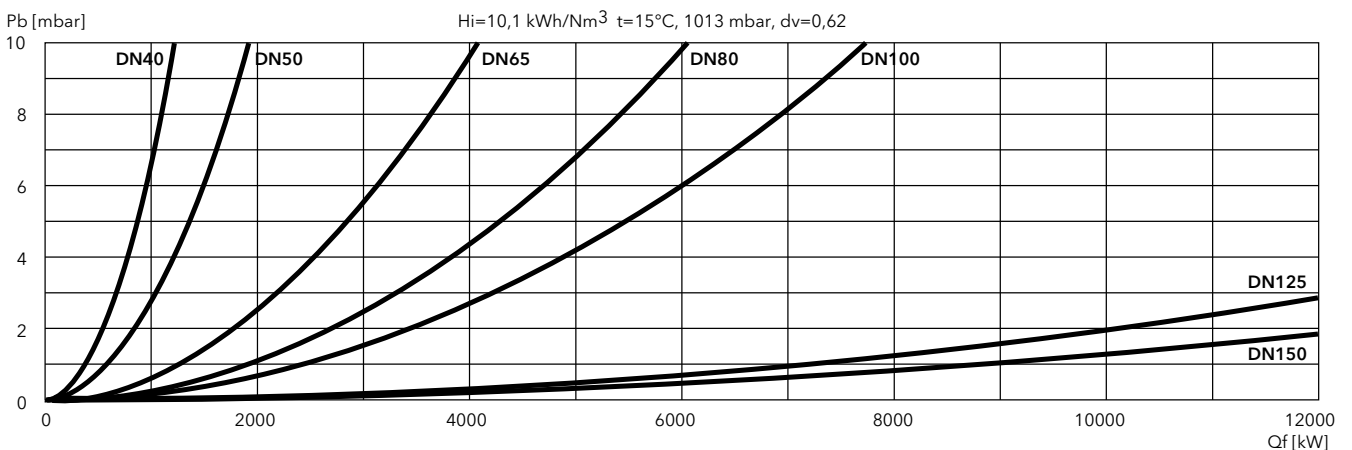

PRESSURE LOSSES (BURNER HEAD + GAS TRAIN)

N7.3600 G-EF3

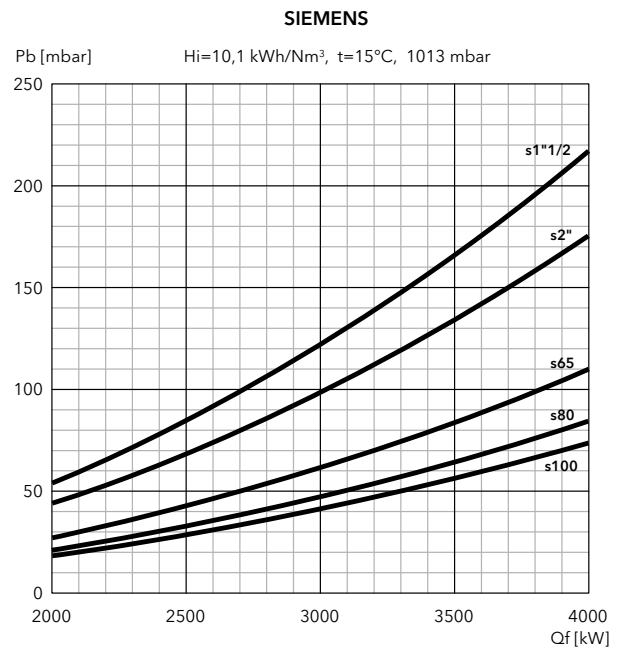
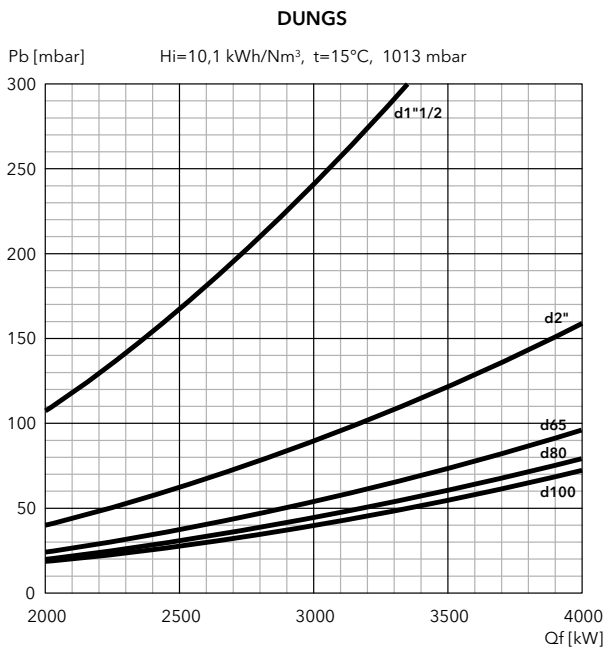

N7.4500 G-EF3

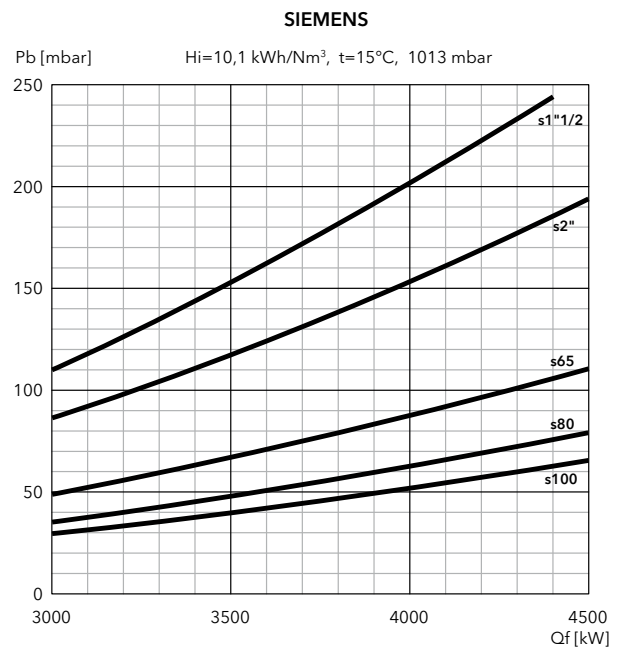
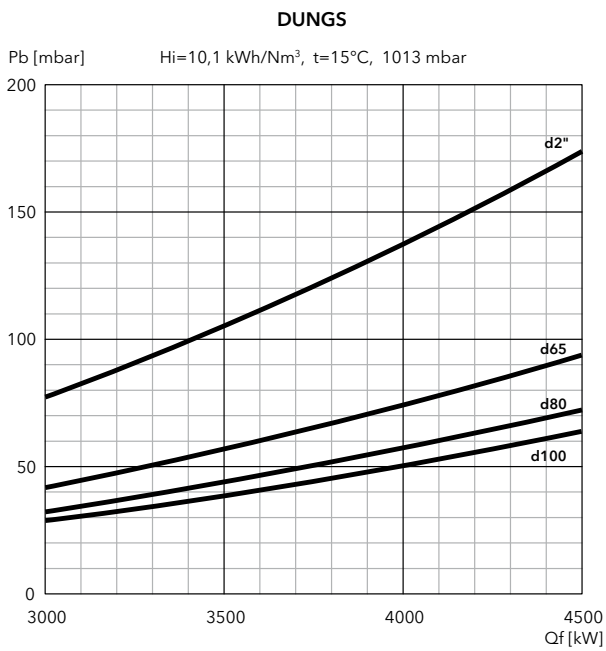

FILTERS

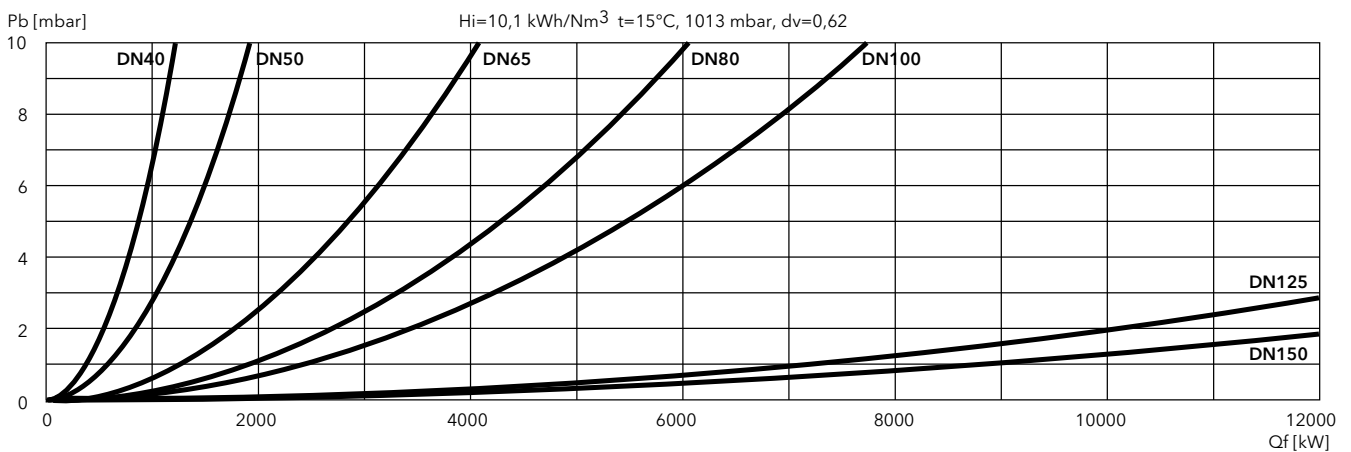

N8 G-EU3, N9 G-EU3

640 ... 10200 kW

2 stage progressive/modulating electronic (Low NOx class 3)

- **Fuels:** natural gas, Hi = 6,99 ... 11,39 kWh/Nm³;
LPG, Hi = 25,89 kWh/Nm³
- **Emission class:** Low NOx class 3 (≤80 mg/kWh) according to EN676
- **Protection level:** IP 41



TECHNICAL DATA

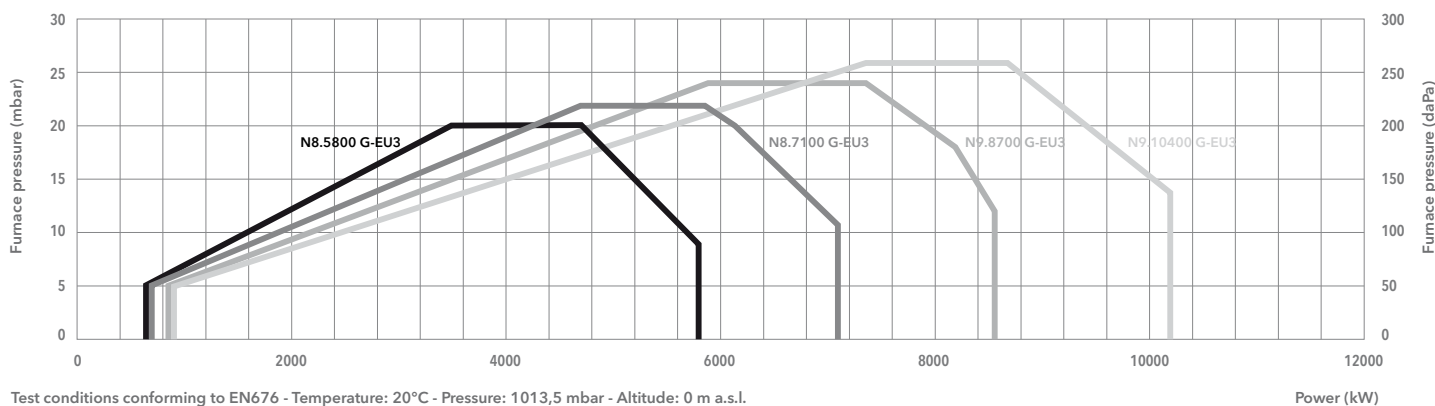

Test conditions conforming to EN676 - Temperature: 20°C - Pressure: 1013,5 mbar - Altitude: 0 m a.s.l.

	N8.5800 G-EU3	N8.7100 G-EU3	N9.8700 G-EU3	N9.10400 G-EU3
Operating range	640 - 5800 kW	700 - 7100 kW	850 - 8530 kW	900 - 10200 kW
Gas pressure	70 - 500 mbar (70 - 360 mbar for d457 gas train)		80 - 500 mbar (80 - 360 mbar for d457 gas train)	
Gas connection	DN100	DN100	DN100	DN100
Control box / flame detector	BT300 / Ionisation	BT300 / Ionisation	BT300 / Ionisation	BT300 / Ionisation
Auxiliary voltage	1NPE AC 230 V - 50 Hz TN-S	1NPE AC 230 V - 50 Hz TN-S	1NPE AC 230 V - 50 Hz TN-S	1NPE AC 230 V - 50 Hz TN-S
Power supply	3PE AC 400 V - 50 Hz	3PE AC 400 V - 50 Hz	3PE AC 400 V - 50 Hz	3PE AC 400 V - 50 Hz
Fan motor	50 Hz - 11 kW	50 Hz - 15 kW	50 Hz - 18,5 kW	50 Hz - 22 kW
Acoustic level	<78 dB(A)	<78 dB(A)	<80 dB(A)	<81 dB(A)
CE certificate	0085CL0215	0085CL0215	0085CL0215	0085CL0215
Complete burner codes	on request	on request	on request	on request

GAS TRAINS

DUNGS

Model	Code
GT-d457-2" (*)	3750515
GT-d458-65	3750516
GT-d459-80	3750517
GT-d460-100	3750518

*: integrated filter

SIEMENS

Model	Code
GT-s457-2"	3750537
GT-s458-65	3750538
GT-s459-80	3750539
GT-s460-100	3750540
GT-s461-125	3750541

FILTERS

Model	Code
FG-Rp2"	3757200
FG-DN65	3757198
FG-DN80	3757201
FG-DN100	3757195
FG-DN125	3757209

Pressure drops graphs: see following pages
Dimensions of gas trains and gas filters: see pag. 207

MDE2

GEM

Variatron

Low Noise

LOW NOx CLASS 3

DIMENSIONS (mm)

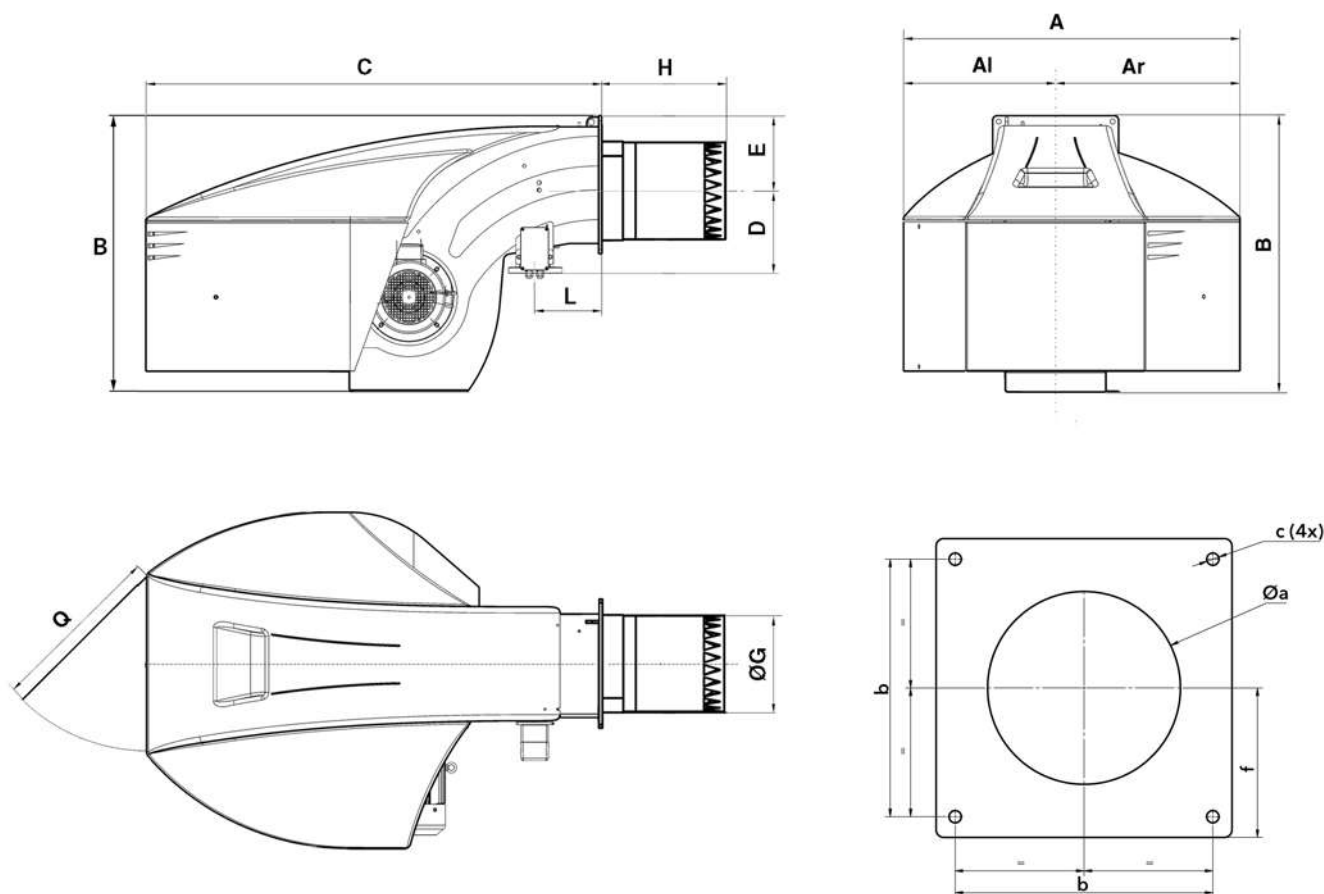

Model	A	Al	Ar	B	C	D	E	ØG	H			L	Q	Øa	b	c	f
									KN	KM	KL						
N8	1414	669	745	1231	1930	344	293	369	500	640	780	230	800	390-410	505	M20	293
N9	1414	669	745	1291	1928	369	293	431,5	550	700	850	230	800	460-480	505	M20	293

PACKAGING

The burner is delivered on a pallet in 2 packages containing:

- burner body with mounted combustion head, boiler fixing accessories and technical documentation;
- gas train and filter.

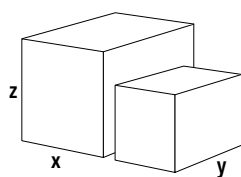

Models		Dimensions (mm)			Gross weight (kg)
		X	Y	Z	
N8.5800 G-EU3	KN	2530	1414	1231	527
	KM	2670	1414	1231	527
	KL	2810	1414	1231	527
N8.7100 G-EU3	KN	2530	1414	1231	535
	KM	2670	1414	1231	535
	KL	2810	1414	1231	535
N9.8700 G-EU3	KN	2430	1414	1231	527
	KM	2570	1414	1231	527
	KL	2710	1414	1231	527
N9.10400 G-EU3	KN	2580	1414	1231	535
	KM	2730	1414	1231	535
	KL	2880	1414	1231	535

PRESSURE LOSSES (BURNER HEAD + GAS TRAIN)

N8.5800 G-EU3

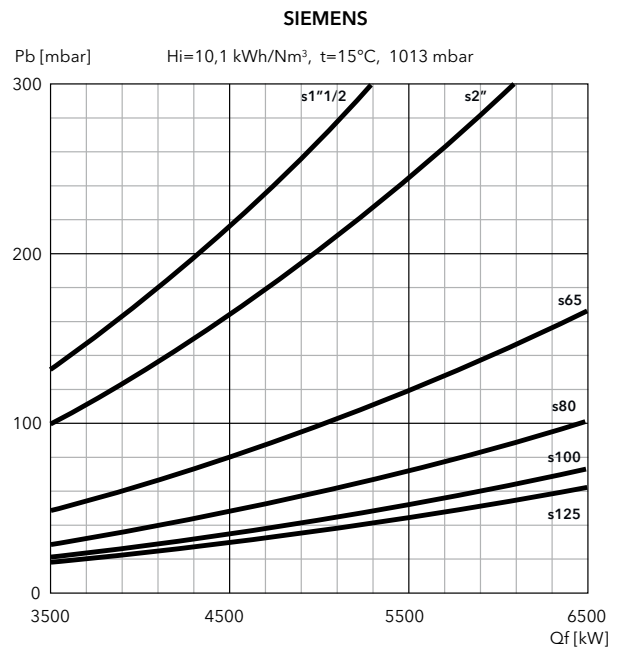
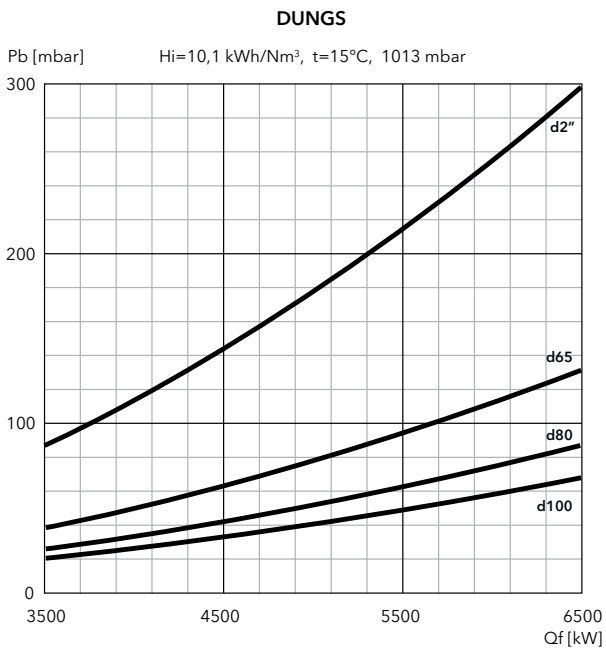

N8.7100 G-EU3

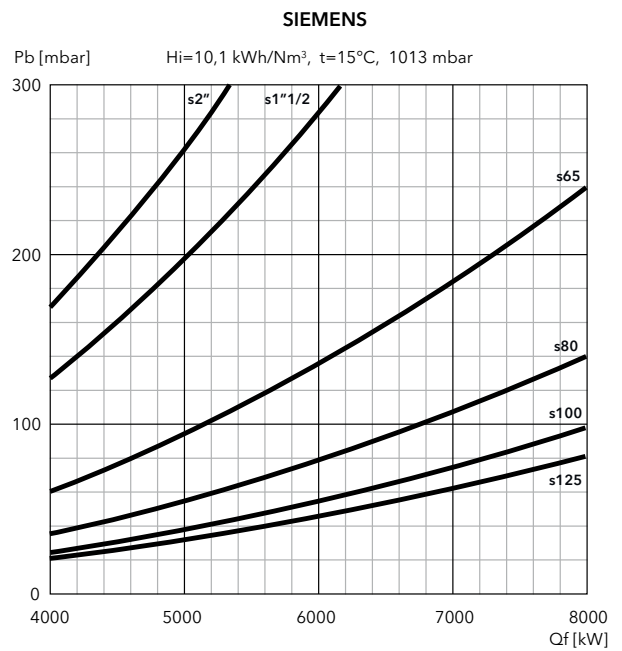
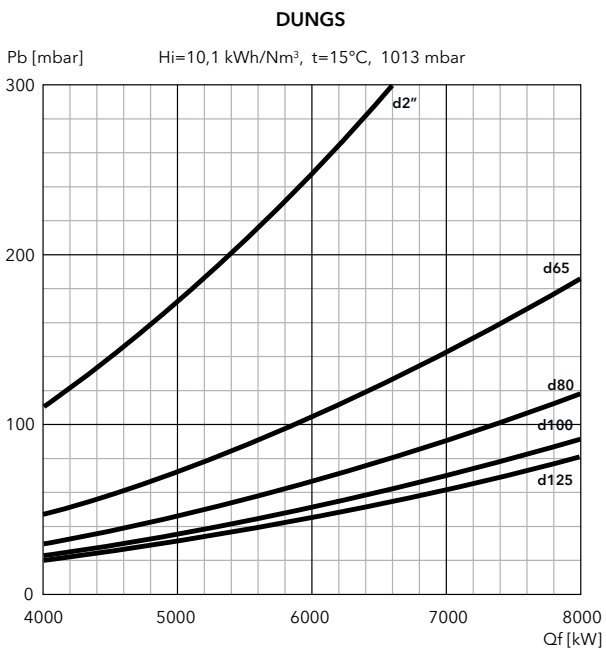

FILTERS

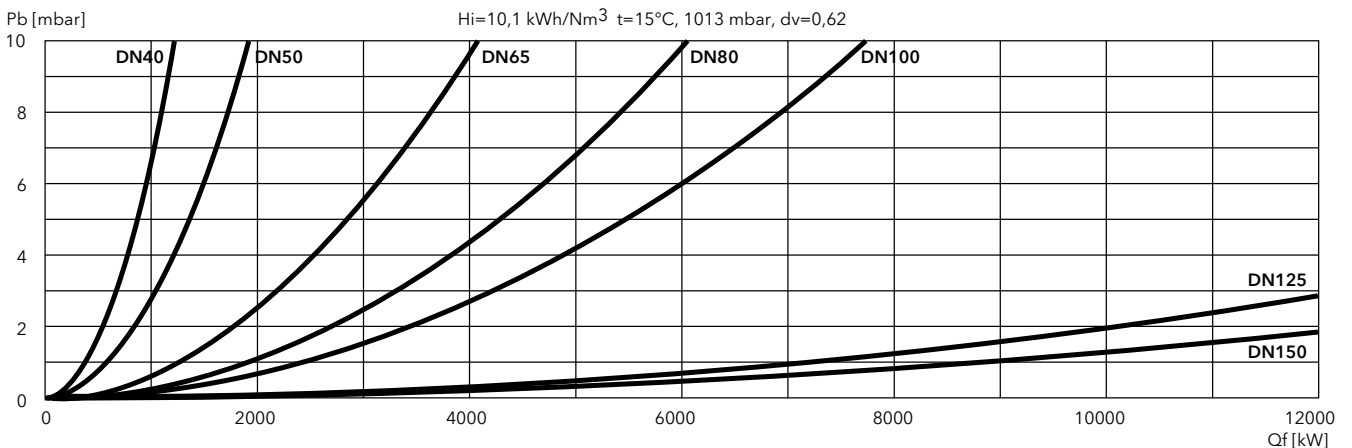

PRESSURE LOSSES (BURNER HEAD + GAS TRAIN)

N9.8700 G-EU3

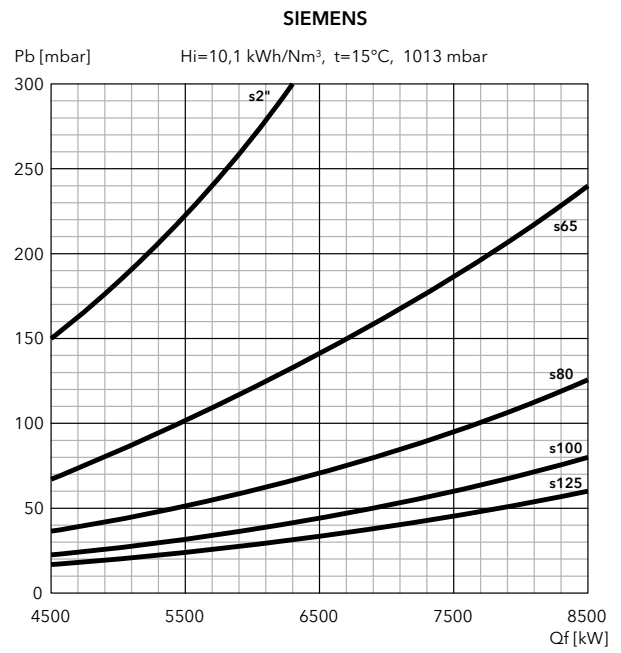
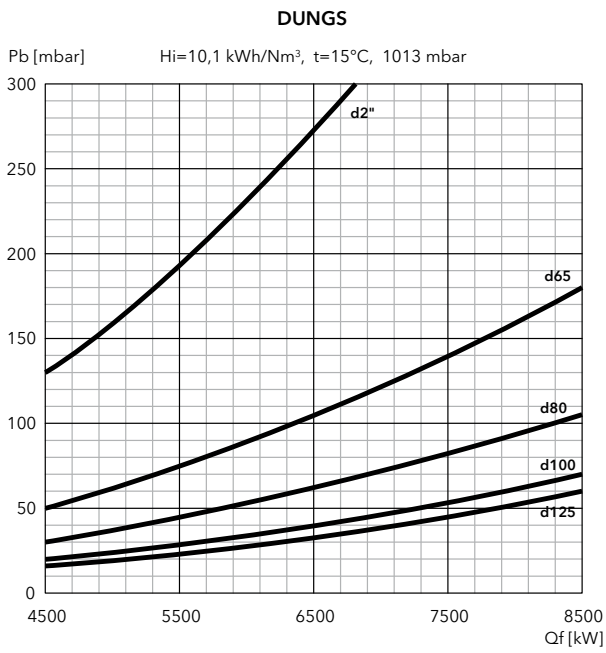

N9.10400 G-EU3

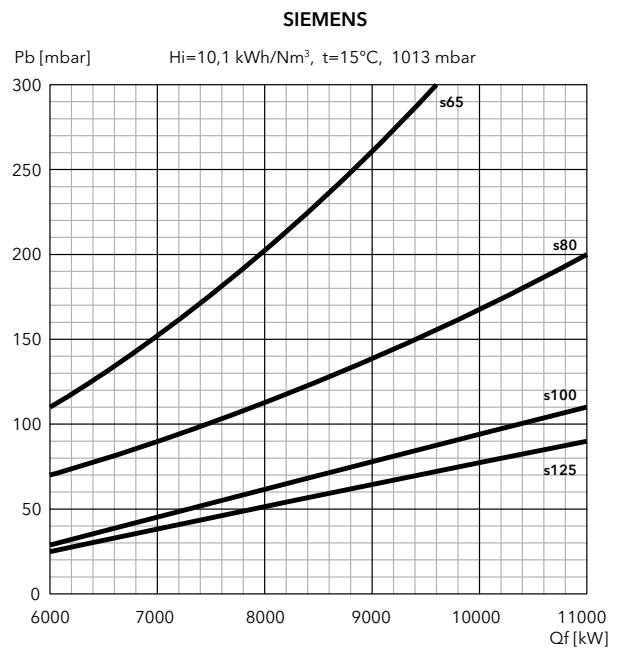
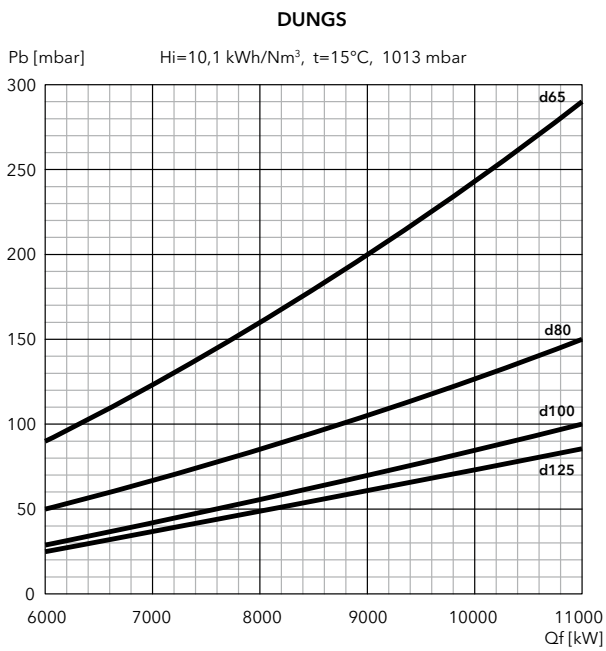

FILTERS

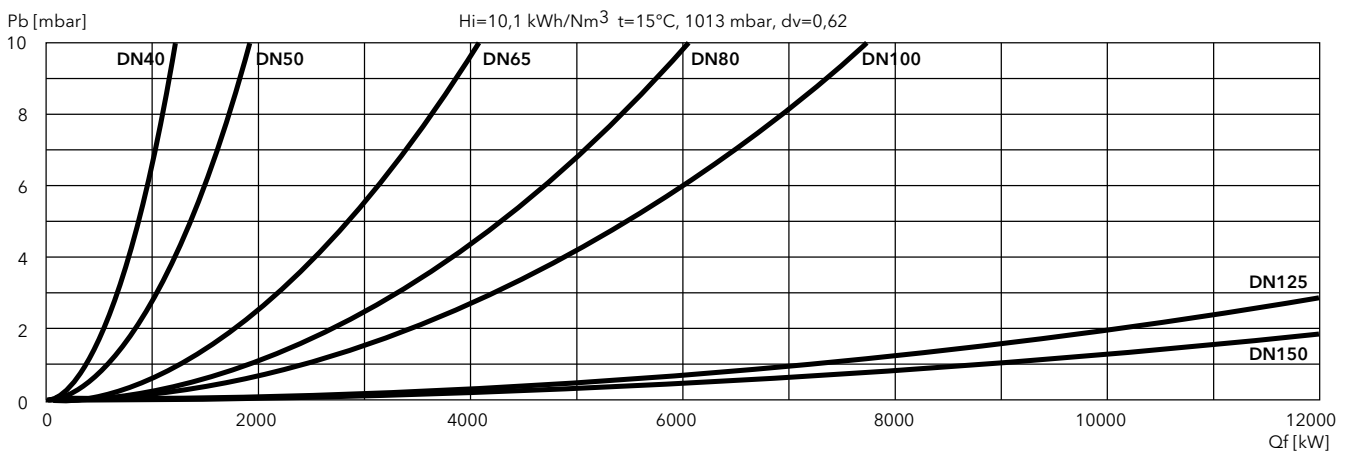

N6 GL-E, N7 GL-E

250 ... 4750 kW

2 stage progressive/modulating electronic

- **Fuels:** natural gas, Hi = 6,99 ... 11,39 kWh/Nm³;
light oil, viscosity 6 mm²/s at 20°C, Hi = 11,86 kWh/kg
- **Emission class:** Low NOx class 2 (≤120 mg/kWh) according to EN676 in gas
Low NOx class 2 (≤185 mg/kWh) according to EN267 in light oil
- **Protection level:** IP 41



TECHNICAL DATA

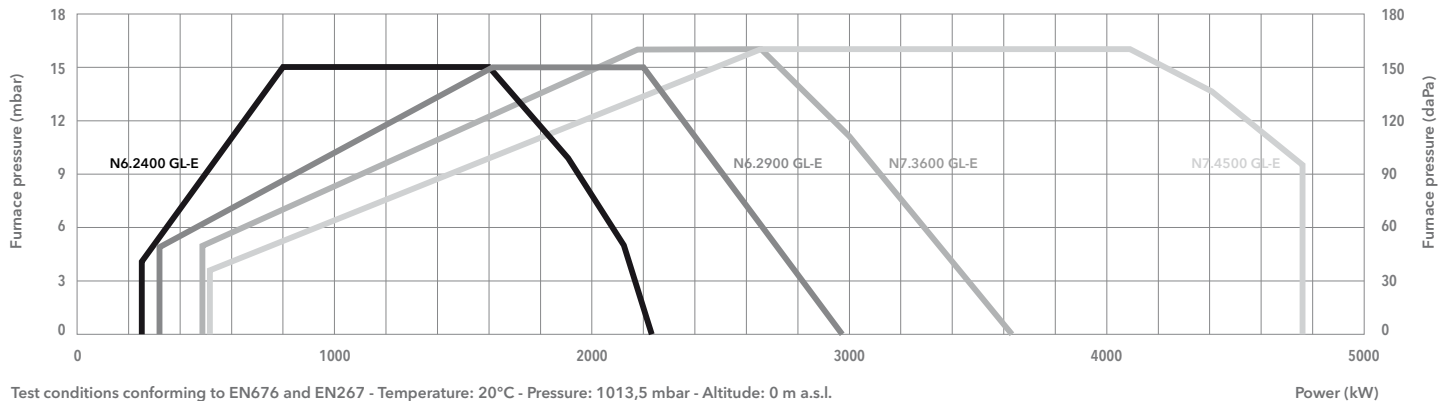

Test conditions conforming to EN676 and EN267 - Temperature: 20°C - Pressure: 1013,5 mbar - Altitude: 0 m a.s.l.

	N6.2400 GL-E	N6.2900 GL-E	N7.3600 GL-E	N7.4500 GL-E
Operating range gas	250 - 2230 kW	320 - 2970 kW	490 - 3650 kW	510 - 4750 kW
Operating range oil	510 - 2030 kW	650 - 2970 kW	900 - 3650 kW	1300 - 4750 kW
Gas pressure	50 - 500 mbar (50 - 360 mbar for d452 and d453 gas train)		50 - 500 mbar (50 - 360 mbar for d452 and d453 gas train)	
Gas connection	DN65	DN65	DN65	DN65
Auxiliary voltage	1NPE AC 230 V - 50 Hz TN-S	1NPE AC 230 V - 50 Hz TN-S	1NPE AC 230 V - 50 Hz TN-S	1NPE AC 230 V - 50 Hz TN-S
Power supply	3PE AC 400 V - 50 Hz	3PE AC 400 V - 50 Hz	3PE AC 400 V - 50 Hz	3PE AC 400 V - 50 Hz
Control box / flame detector	BT300 / QRA2	BT300 / QRA2	BT300 / QRA2	BT300 / QRA2
Fan motor	50 Hz - 3 kW	50 Hz - 4 kW	50 Hz - 5,5 kW	50 Hz - 7,5 kW
Pump	SUNTEC TA3	SUNTEC TA3	SUNTEC TA4	SUNTEC TA4
Motor pump	50 Hz - 0,74 kW	50 Hz - 0,74 kW	50 Hz - 1,1 kW	50 Hz - 1,5 kW
Acoustic level	<70 dB(A)	<71 dB(A)	<74 dB(A)	<74 dB(A)
CE certificate	0085CL0215	0085CL0215	0085CL0215	0085CL0215
Complete burner codes	on request	on request	on request	on request

GAS TRAINS

DUNGS

Model	Code
GT-d452-1"1/2 (*)	3750510
GT-d453-2" (*)	3750511
GT-d454-65	3750512
GT-d455-80	3750513
GT-d456-100	3750514

*: integrated filter

SIEMENS

Model	Code
GT-s451-1"1/2	3750525
GT-s452-2"	3750526
GT-s453-65	3750527
GT-s454-80	3750528
GT-s455-100	3750529
GT-s456-125	3750530

FILTERS

Model	Code
FG-Rp1"1/2	3757199
FG-Rp2"	3757200
FG-DN65	3757198
FG-DN80	3757201
FG-DN100	3757195
FG-DN125	3757209

 **Pressure drops graphs:** see following pages
Dimensions of gas trains and gas filters: see pag. 206



DIMENSIONS (mm)

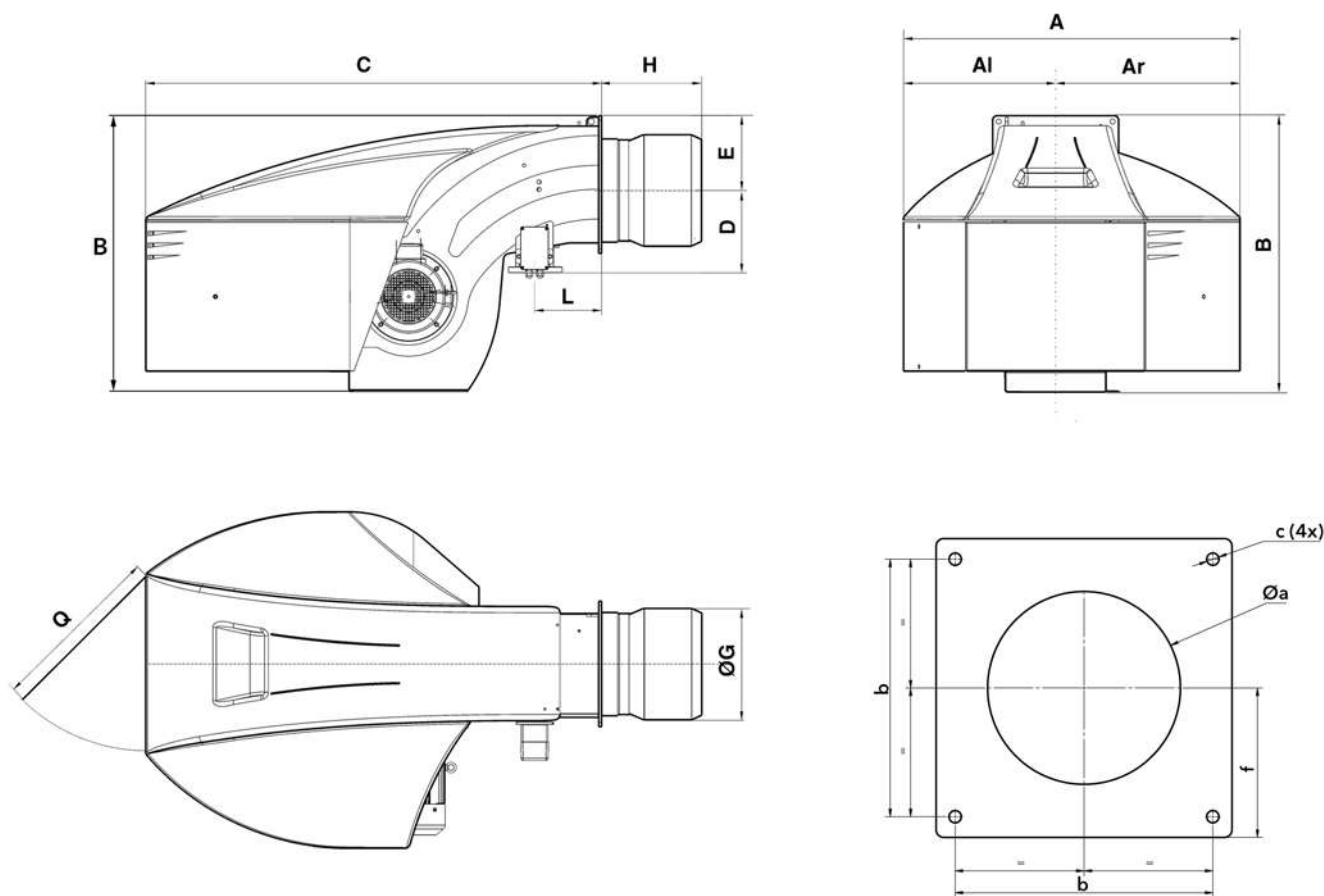

Model	A	Al	Ar	B	C	D	E	ØG	H			L	Q	Øa	b	c	f
									KN	KM	KL						
N6.2400	990	479	510	837	1361	245	225	290	330	450	570	215	600	300-340	340	M16	200
N6.2900	990	479	510	837	1361	245	225	310	330	450	570	215	600	320-340	340	M16	200
N7.3600	1128	511	618	961	1529	276	255	340	375	505	635	225	600	350-400	400	M16	235
N7.4500	1128	511	618	961	1529	276	255	370	375	505	635	225	600	380-400	400	M16	235

PACKAGING

- The burner is delivered on a pallet in 2 packages containing:
- burner body with mounted combustion head, boiler fixing accessories and technical documentation;
 - gas train and filter.

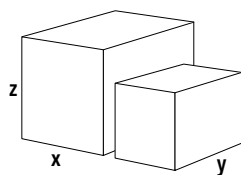

Models		Dimensions (mm)			Gross weight (kg)
		X	Y	Z	
N6.2400 GL-E	KN	1691	990	837	320
	KM	1811	990	837	320
	KL	1931	990	837	320
N6.2900 GL-E	KN	1691	990	837	330
	KM	1811	990	837	330
	KL	1931	990	837	330
N7.3600 GL-E	KN	1904	1128	961	360
	KM	2034	1128	961	360
	KL	2164	1128	961	360
N7.4500 GL-E	KN	1904	1128	961	370
	KM	2034	1128	961	370
	KL	2164	1128	961	370

PRESSURE LOSSES (BURNER HEAD + GAS TRAIN)

N6.2400 GL-E

DUNGS

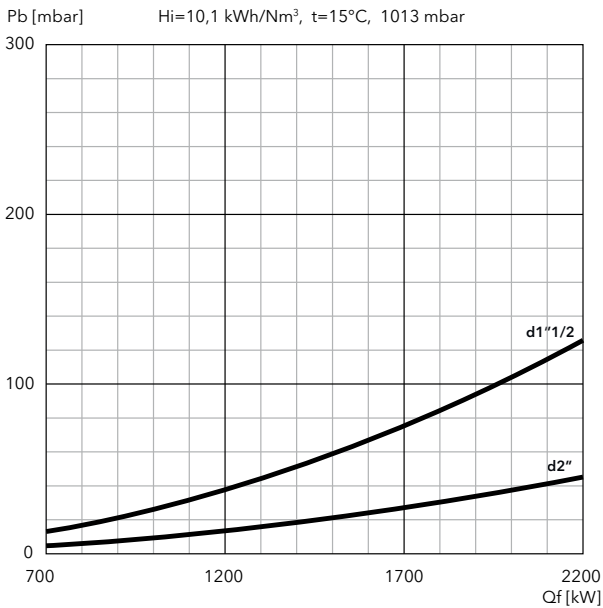

SIEMENS

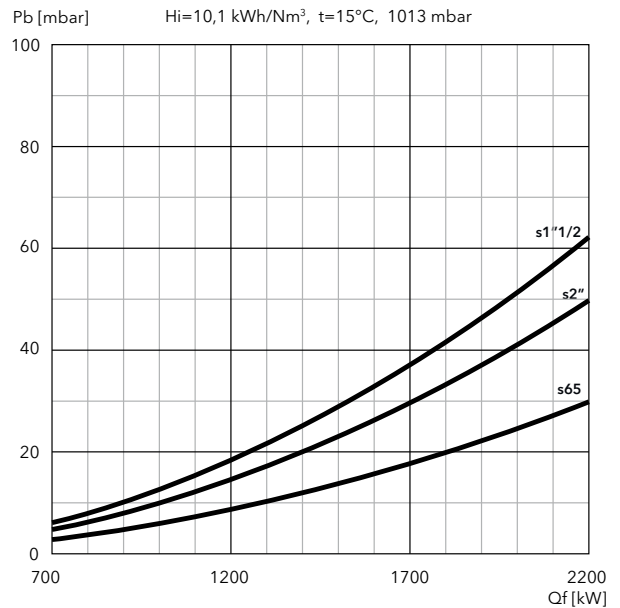

N6.2900 GL-E

DUNGS

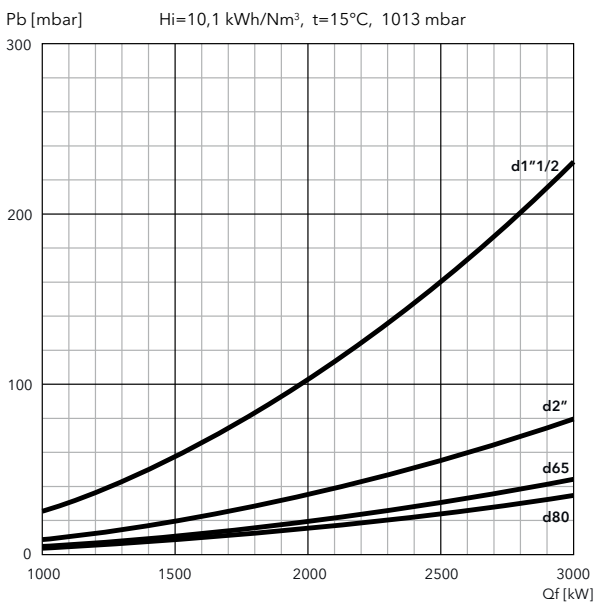

SIEMENS

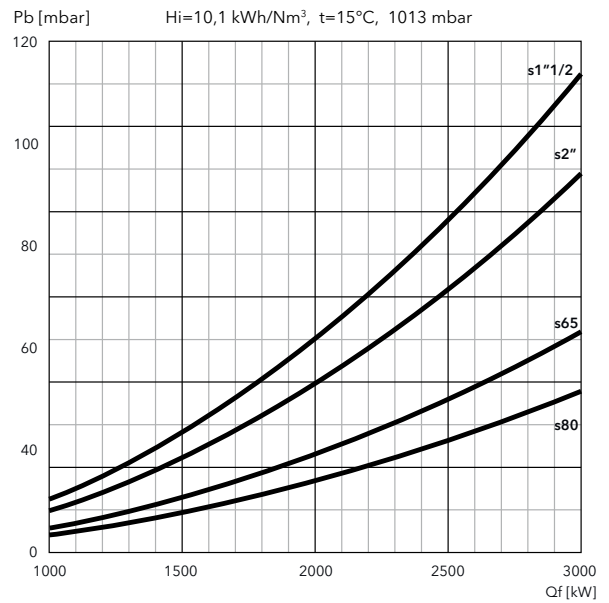

FILTERS

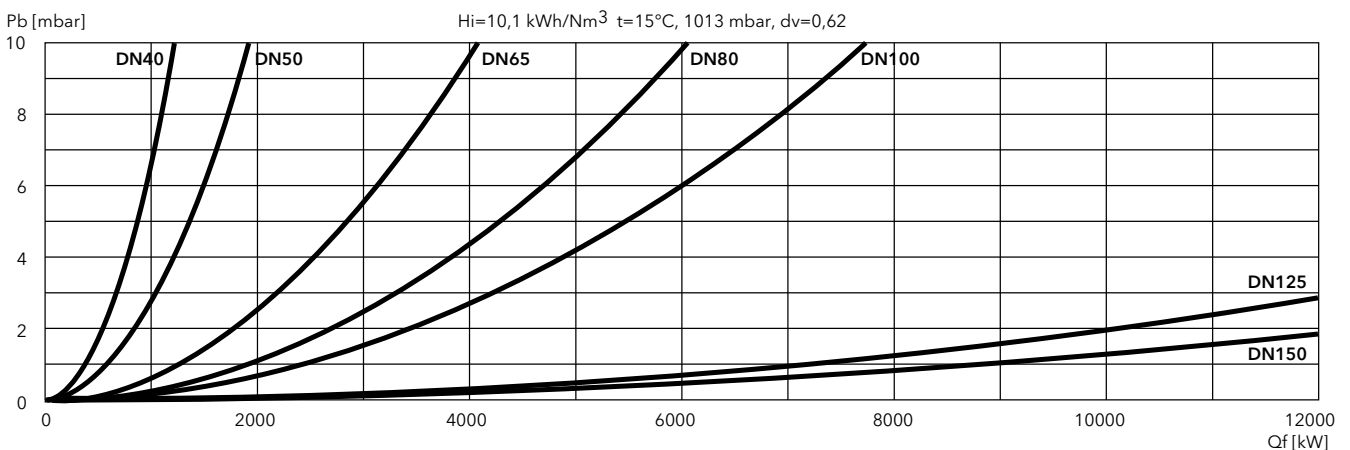

PRESSURE LOSSES (BURNER HEAD + GAS TRAIN)

N7.3600 GL-E

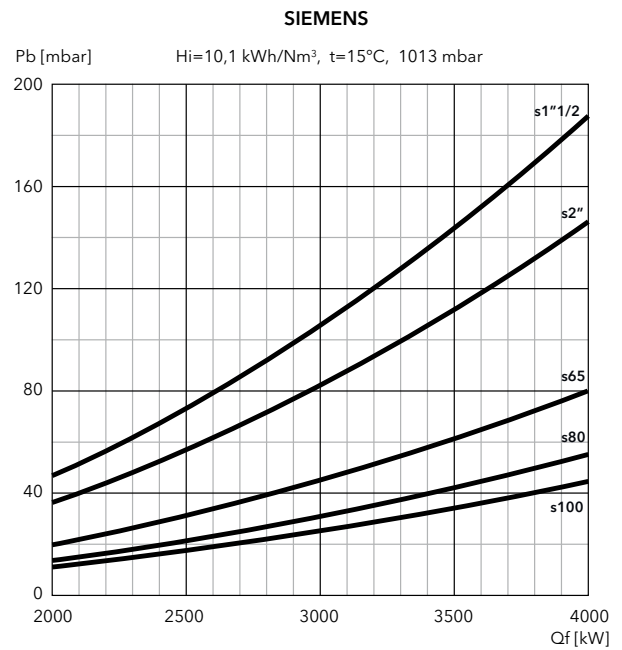
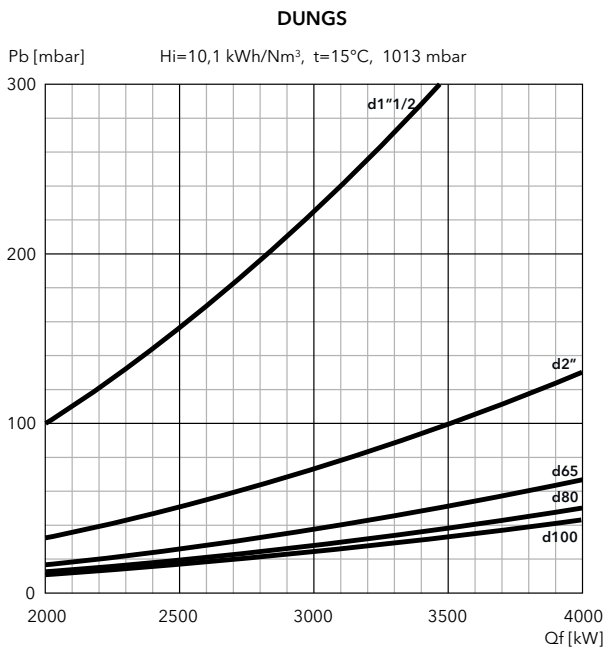

N7.4500 GL-E

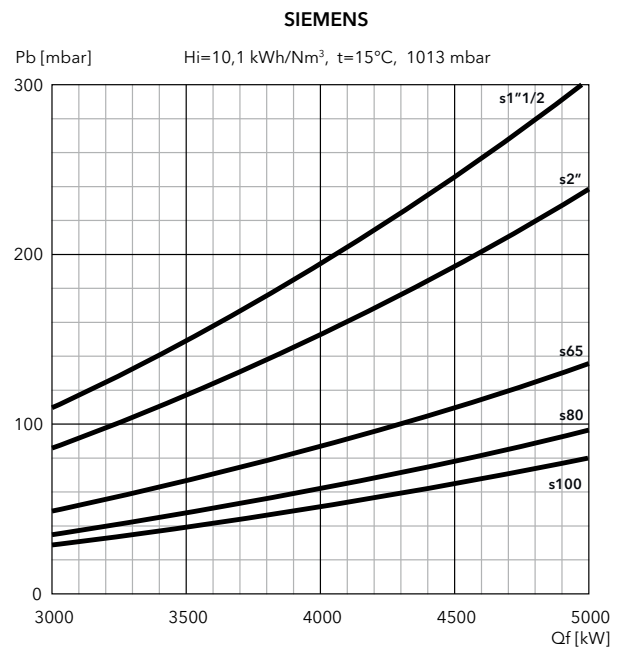
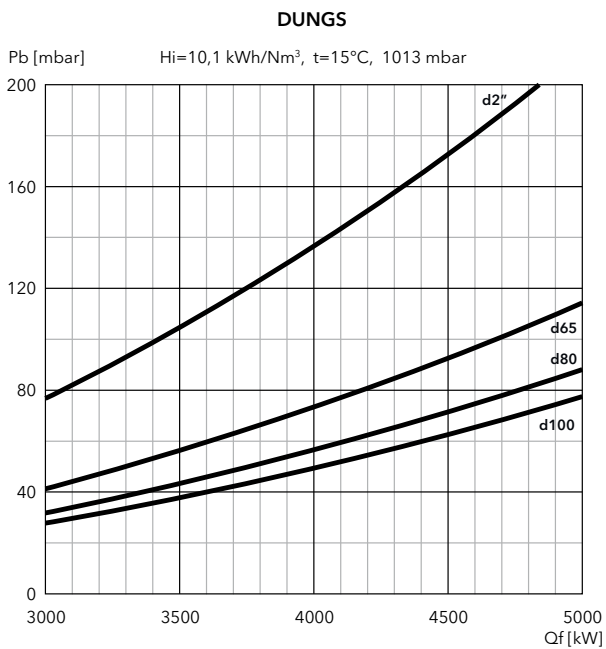

FILTERS

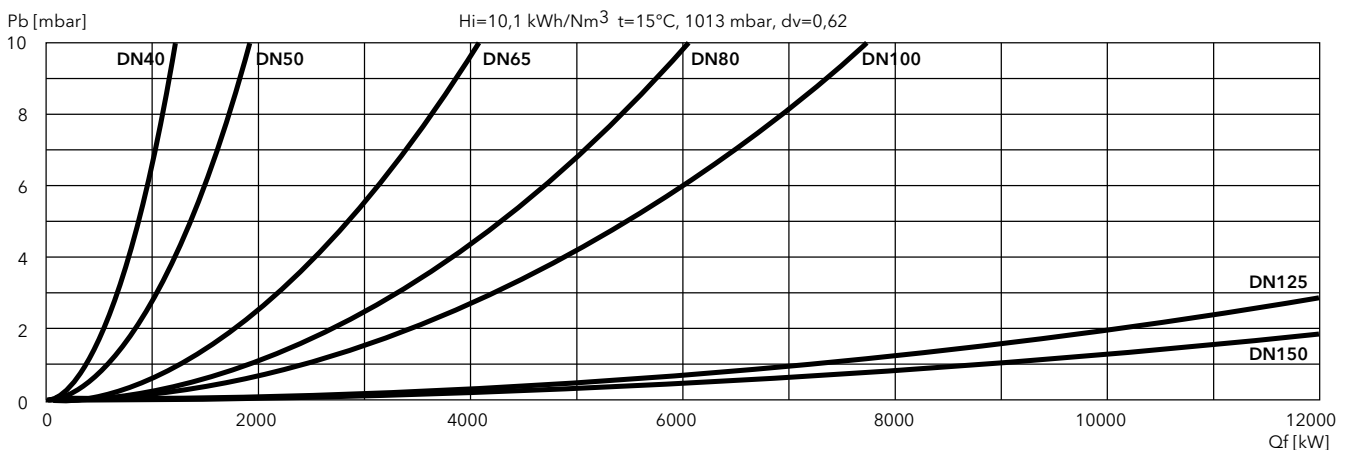

N8 GL-E, N9 GL-E

800 ... 10620 kW

2 stage progressive/modulating electronic

- **Fuels:** natural gas, Hi = 6,99 ... 11,39 kWh/Nm³;
light oil, viscosity 6 mm²/s at 20°C, Hi = 11,86 kWh/kg
- **Emission class:** Low NOx class 2 (≤120 mg/kWh) according to EN676 in gas
Low NOx class 2 (≤185 mg/kWh) according to EN267 in light oil
- **Protection level:** IP 41



TECHNICAL DATA

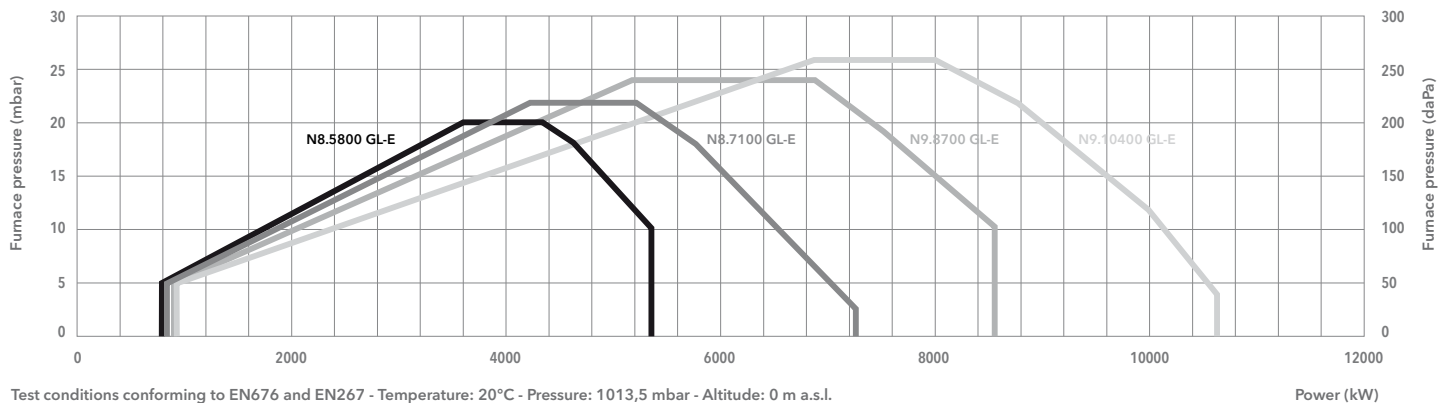

Test conditions conforming to EN676 and EN267 - Temperature: 20°C - Pressure: 1013,5 mbar - Altitude: 0 m a.s.l.

Power (kW)

	N8.5800 GL-E	N8.7100 GL-E	N9.8700 GL-E	N9.10400 GL-E
Operating range gas	800 - 5350 kW	820 - 7340 kW	880 - 8530 kW	910 - 10620 kW
Operating range oil	1210 - 5350 kW	1470 - 7340 kW	2400 - 8530 kW	2820 - 10620 kW
Gas pressure	100 - 500 mbar (100 - 360 mbar for d457 gas train)		100 - 500 mbar (100 - 360 mbar for d457 gas train)	
Gas connection	DN100	DN100	DN100	DN100
Auxiliary voltage	1NPE AC 230 V - 50 Hz TN-S	1NPE AC 230 V - 50 Hz TN-S	1NPE AC 230 V - 50 Hz TN-S	1NPE AC 230 V - 50 Hz TN-S
Power supply	3PE AC 400 V - 50 Hz	3PE AC 400 V - 50 Hz	3PE AC 400 V - 50 Hz	3PE AC 400 V - 50 Hz
Control box / flame detector	BT300 / QRA2	BT300 / QRA2	BT300 / QRA2	BT300 / QRA2
Fan motor	50 Hz - 11 kW	50 Hz - 15 kW	50 Hz - 18,5 kW	50 Hz - 22 kW
Pump	SMG1630 - 1700 l/h	SMG1630 - 1700 l/h	SMG1630 - 1700 l/h	SMG1631 - 2200 l/h
Motor pump	50 Hz - 3 kW	50 Hz - 3 kW	50 Hz - 3 kW	50 Hz - 4 kW
Acoustic level	<77,4 dB(A)	<79,5 dB(A)	<81 dB(A)	<81,7 dB(A)
CE certificate	0085CL0215	0085CL0215	0085CL0215	0085CL0215
Complete burner codes	on request	on request	on request	on request

GAS TRAINS

DUNGS

Model	Code
GT-d457-2" (*)	3750515
GT-d458-65	3750516
GT-d459-80	3750517
GT-d460-100	3750518

*: integrated filter

SIEMENS

Model	Code
GT-s457-2"	3750537
GT-s458-65	3750538
GT-s459-80	3750539
GT-s460-100	3750540
GT-s461-125	3750541

FILTERS

Model	Code
FG-Rp2"	3757200
FG-DN65	3757198
FG-DN80	3757201
FG-DN100	3757195
FG-DN125	3757209

 **Pressure drops graphs:** see following pages
Dimensions of gas trains and gas filters: see pag. 207



DIMENSIONS (mm)

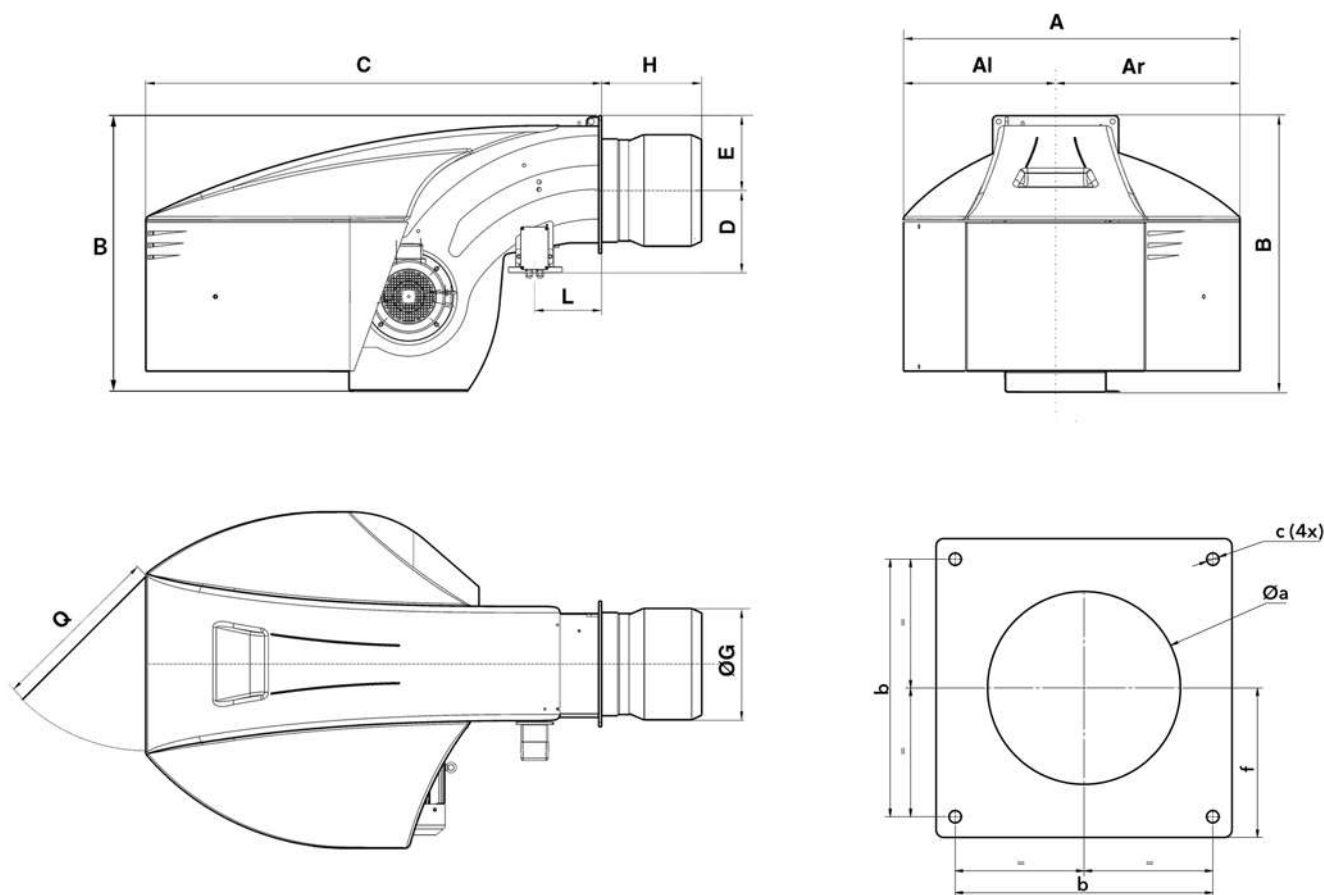

Model	A	Al	Ar	B	C	D	E	ØG	H			L	Q	Øa	b	c	f
									KN	KM	KL						
N8.5800	1414	669	745	1231	1930	391	293	400	562	702	842	230	800	430-480	505	M20	293
N8.7100	1414	669	745	1231	1930	391	293	415	583	723	863	230	800	445-480	505	M20	293
N9	1414	669	745	1291	1928	434	293	431,5	355	505	655	230	800	445-480	505	M20	293

PACKAGING

The burner is delivered on a pallet in 2 packages containing:

- burner body with mounted combustion head, boiler fixing accessories and technical documentation;
- gas train and filter.

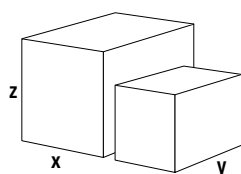

Models		Dimensions (mm)			Gross weight (kg)
		X	Y	Z	
N8.5800 GL-E	KN	2582	1414	1231	638
	KM	2632	1414	1231	647
	KL	2772	1414	1231	653
N8.7100 GL-E	KN	2513	1414	1231	640
	KM	2653	1414	1231	649
	KL	2793	1414	1231	655
N9.8700 GL-E	KN	2283	1414	1291	662
	KM	2433	1414	1291	669
	KL	2583	1414	1291	677
N9.10400 GL-E	KN	2283	1414	1291	672
	KM	2433	1414	1291	679
	KL	2583	1414	1291	687

PRESSURE LOSSES (BURNER HEAD + GAS TRAIN)

N8.5800 GL-E

DUNGS

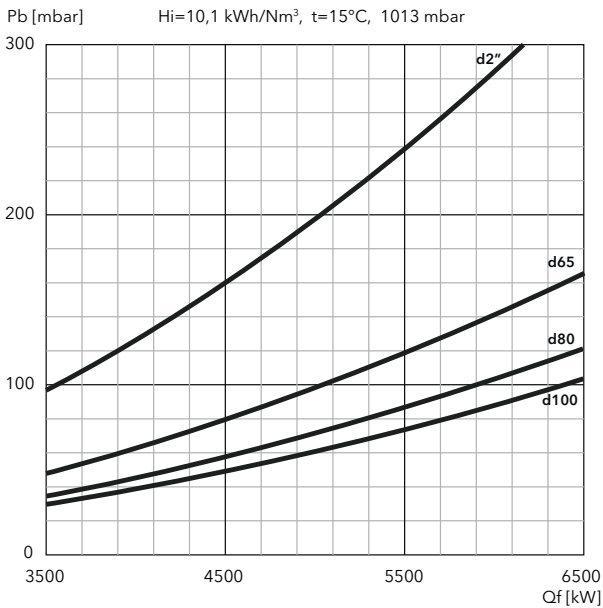

SIEMENS

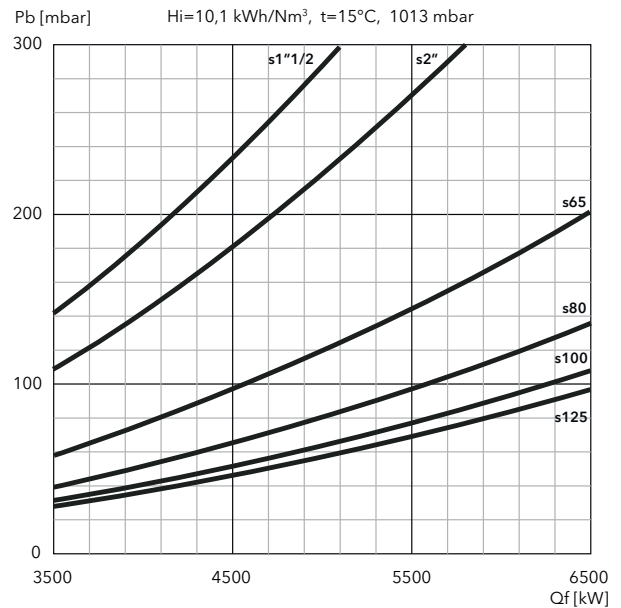

N8.7100 GL-E

DUNGS

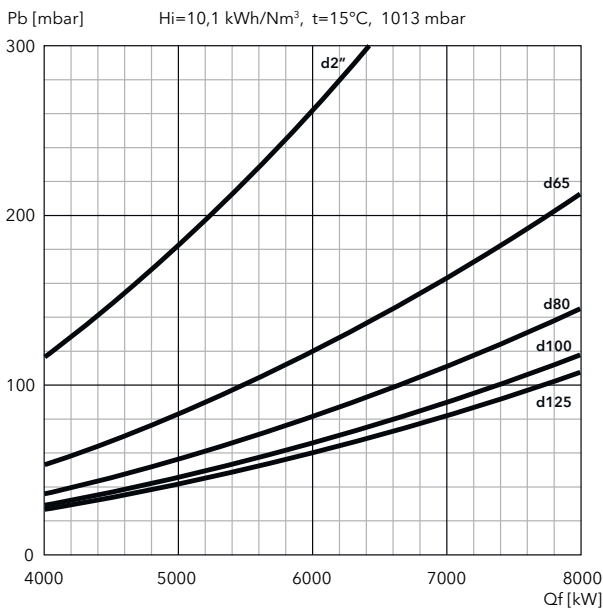

SIEMENS

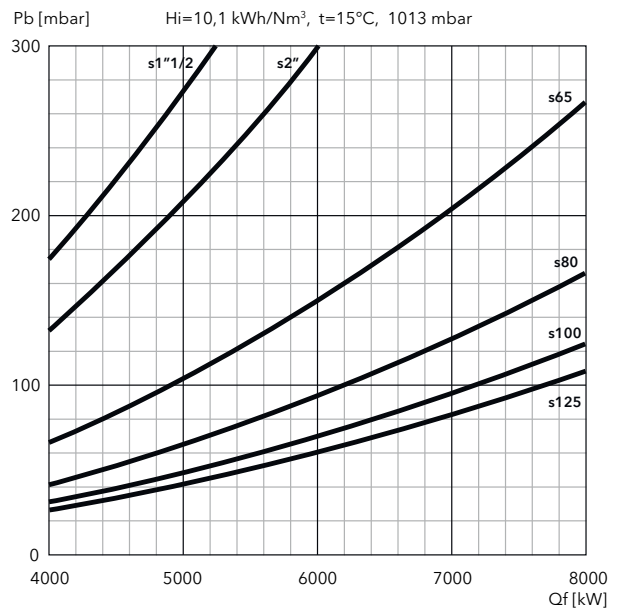

FILTERS

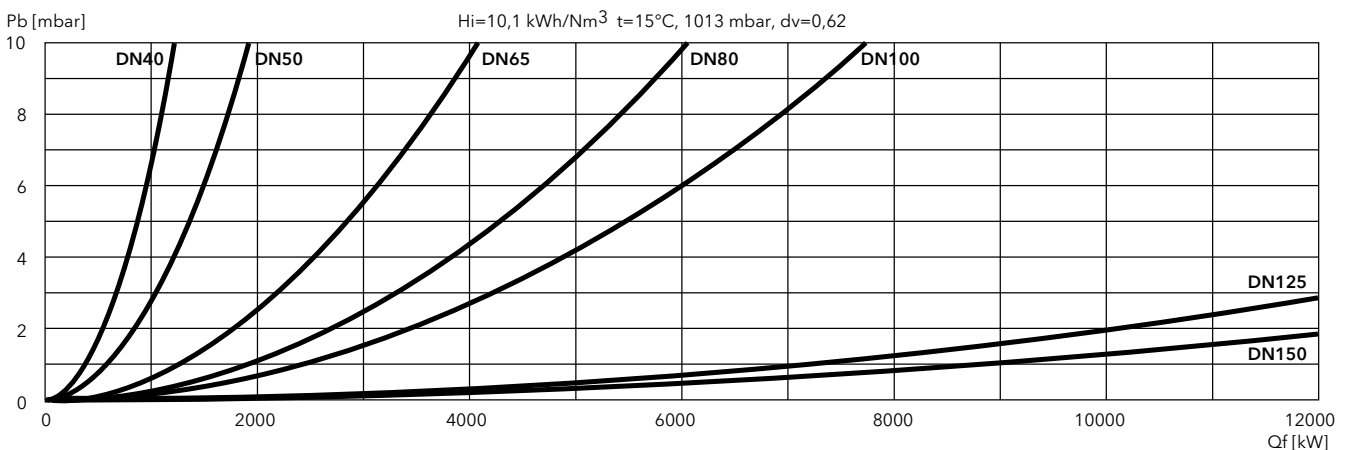

PRESSURE LOSSES (BURNER HEAD + GAS TRAIN)

N9.8700 GL-E

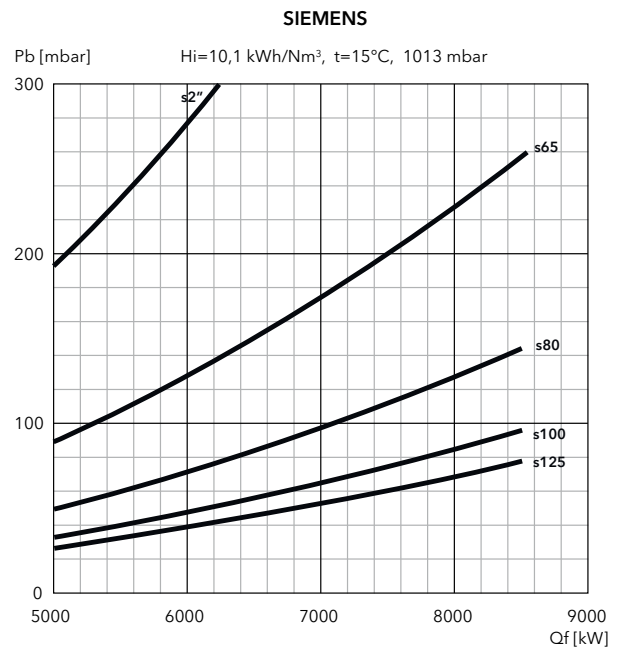
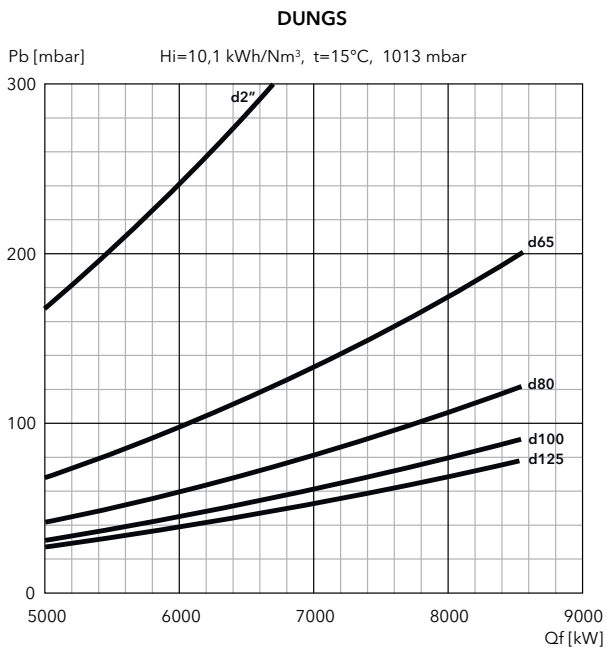

N9.10400 GL-E

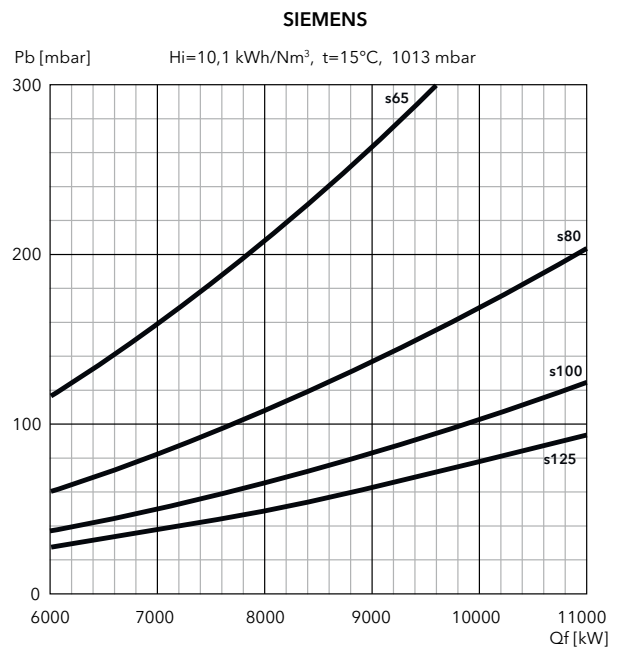
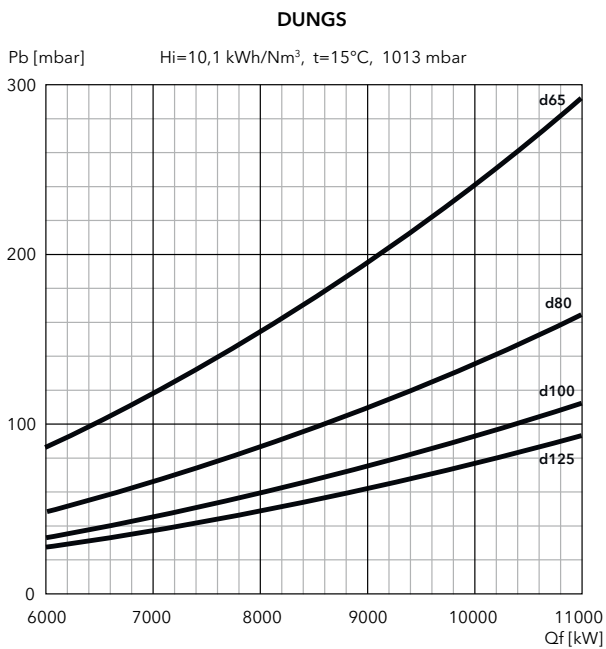

FILTERS

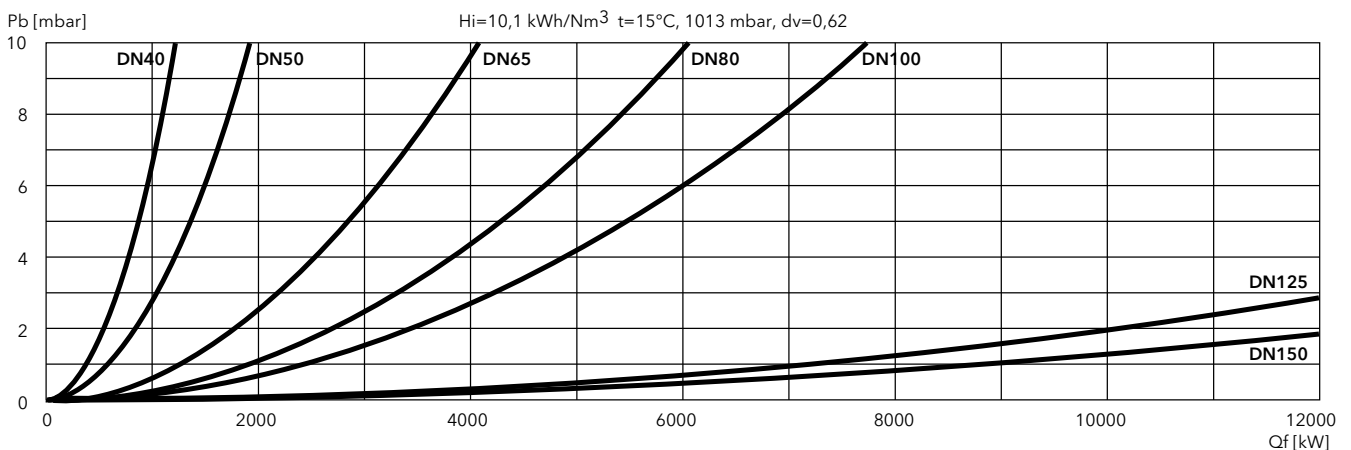

N6 GL-EF3, N7 GL-EF3

280 ... 4500 kW

2 stage progressive/modulating electronic (Low NOx class 3)

- **Fuels:** natural gas, Hi = 6,99 ... 11,39 kWh/Nm³;
light oil, viscosity 6 mm²/s at 20°C, Hi = 11,86 kWh/kg
- **Emission class:** Low NOx class 3 (≤80 mg/kWh) according to EN676 in gas
Low NOx class 3 (≤120 mg/kWh) according to EN267 in light oil
- **Protection level:** IP 41



TECHNICAL DATA

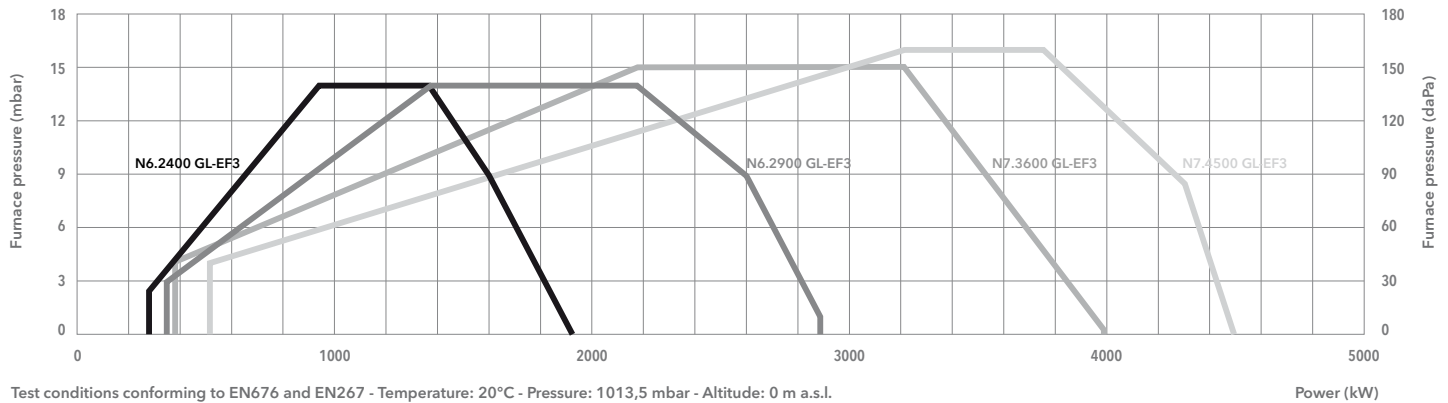

Test conditions conforming to EN676 and EN267 - Temperature: 20°C - Pressure: 1013,5 mbar - Altitude: 0 m a.s.l.

Power (kW)

	N6.2400 GL-EF3	N6.2900 GL-EF3	N7.3600 GL-EF3	N7.4500 GL-EF3
Operating range gas	280 - 1920 kW	340 - 2890 kW	470 - 3980 kW	510 - 4500 kW
Operating range oil	360 - 1920 kW	740 - 2890 kW	680 - 3980 kW	740 - 4500 kW
Gas pressure	50 - 500 mbar (50 - 360 mbar for d452 and d453 gas train)		50 - 500 mbar (50 - 360 mbar for d452 and d453 gas train)	
Gas connection	DN65	DN65	DN65	DN65
Auxiliary voltage	1NPE AC 230 V - 50 Hz TN-S	1NPE AC 230 V - 50 Hz TN-S	1NPE AC 230 V - 50 Hz TN-S	1NPE AC 230 V - 50 Hz TN-S
Power supply	3PE AC 400 V - 50 Hz	3PE AC 400 V - 50 Hz	3PE AC 400 V - 50 Hz	3PE AC 400 V - 50 Hz
Control box / flame detector	BT300 / D-LX 100 EK-S	BT300 / D-LX 100 EK-S	BT300 / D-LX 100 EK-S	BT300 / D-LX 100 EK-S
Fan motor	50 Hz - 3 kW	50 Hz - 4 kW	50 Hz - 7,5 kW	50 Hz - 7,5 kW
Pump	SUNTEC TA3	SUNTEC TA3	SUNTEC TA4	SUNTEC TA4
Motor pump	50 Hz - 0,74 kW	50 Hz - 0,74 kW	50 Hz - 1,1 kW	50 Hz - 1,5 kW
Acoustic level	<71 dB(A)	<71 dB(A)	<76 dB(A)	<74 dB(A)
CE certificate	0085CL0215	0085CL0215	0085CL0215	0085CL0215
Complete burner codes	on request	on request	on request	on request

GAS TRAINS

DUNGS

Model	Code
GT-d452-1"1/2 (*)	3750510
GT-d453-2" (*)	3750511
GT-d454-65	3750512
GT-d455-80	3750513
GT-d456-100	3750514

*: integrated filter

SIEMENS

Model	Code
GT-s451-1"1/2	3750525
GT-s452-2"	3750526
GT-s453-65	3750527
GT-s454-80	3750528
GT-s455-100	3750529
GT-s456-125	3750530

FILTERS

Model	Code
FG-Rp1"1/2	3757199
FG-Rp2"	3757200
FG-DN65	3757198
FG-DN80	3757201
FG-DN100	3757195
FG-DN125	3757209

 **Pressure drops graphs:** see following pages
Dimensions of gas trains and gas filters: see pag. 206



DIMENSIONS (mm)

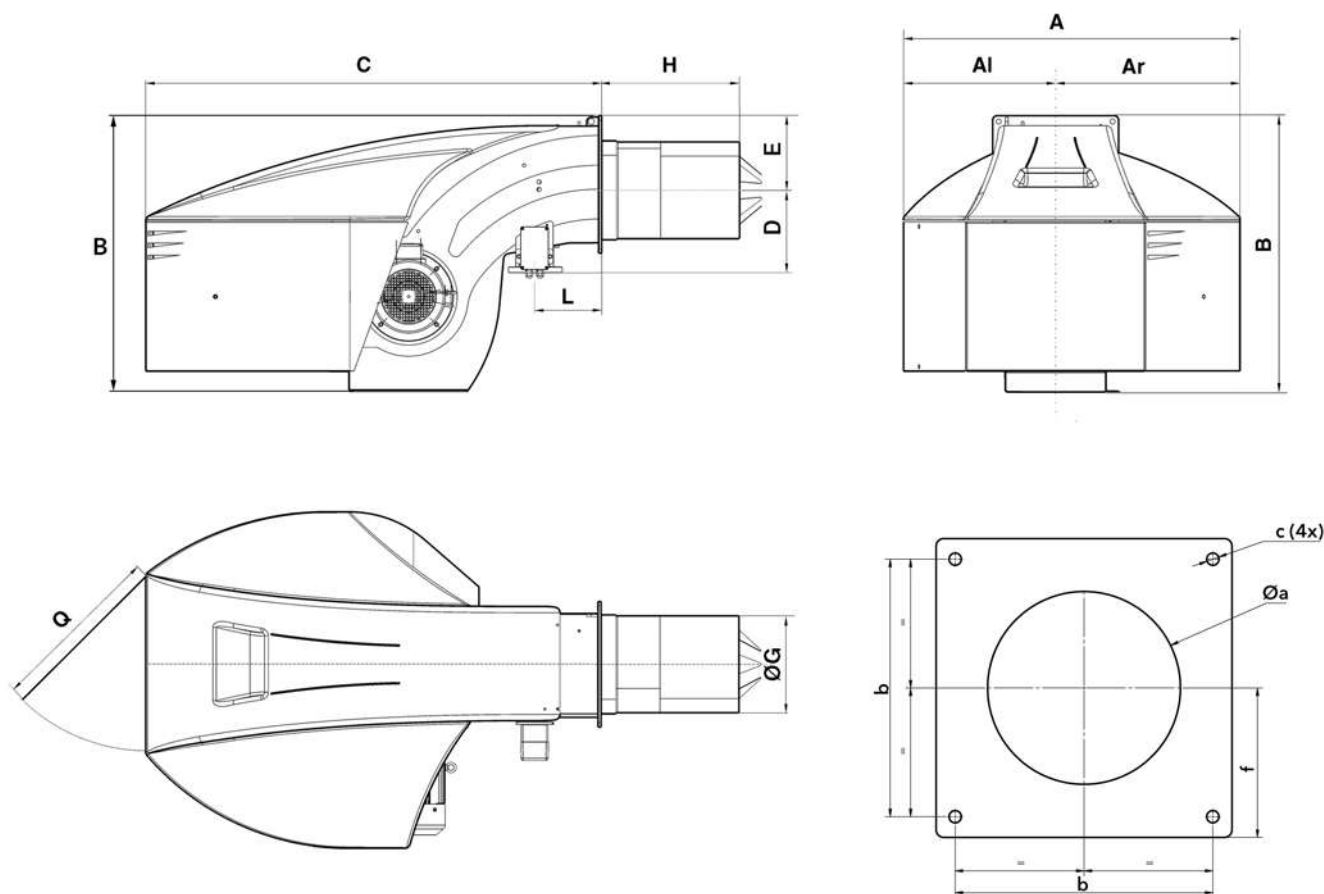

Model	A	Al	Ar	B	C	D	E	ØG	H			L	Q	Øa	b	c	f
									KN	KM	KL						
N6	990	479	510	837	1361	245	225	264	400	520	640	215	600	300-340	340	M16	200
N7	1128	511	618	961	1529	276	255	325	420	550	680	225	600	360-400	400	M16	235

PACKAGING

The burner is delivered on a pallet in 2 packages containing:

- burner body with mounted combustion head, boiler fixing accessories and technical documentation;
- gas train and filter.

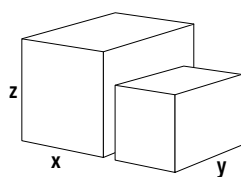

Models		Dimensions (mm)			Gross weight (kg)
		X	Y	Z	
N6.2400 GL-EF3	KN	1861	990	837	320
	KM	1981	990	837	320
	KL	2101	990	837	320
N6.2900 GL-EF3	KN	1861	990	837	330
	KM	1981	990	837	330
	KL	2101	990	837	330
N7.3600 GL-EF3	KN	2029	1128	961	360
	KM	2179	1128	961	360
	KL	2309	1128	961	360
N7.4500 GL-EF3	KN	2029	1128	961	370
	KM	2179	1128	961	370
	KL	2309	1128	961	370

PRESSURE LOSSES (BURNER HEAD + GAS TRAIN)

N6.2400 GL-EF3

DUNGS

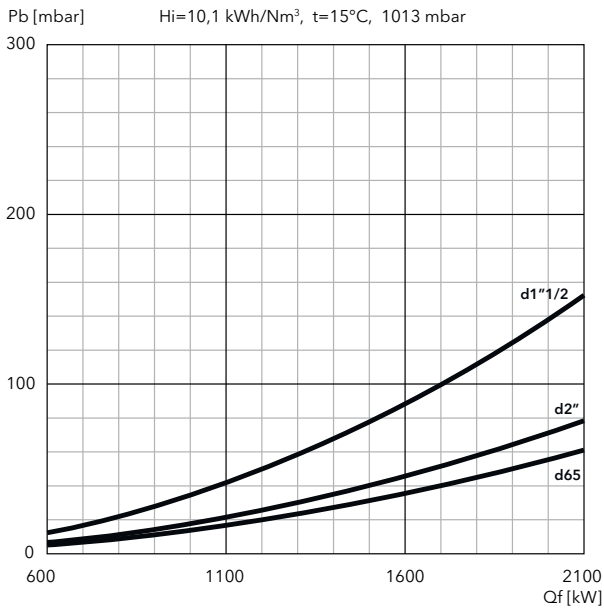

SIEMENS

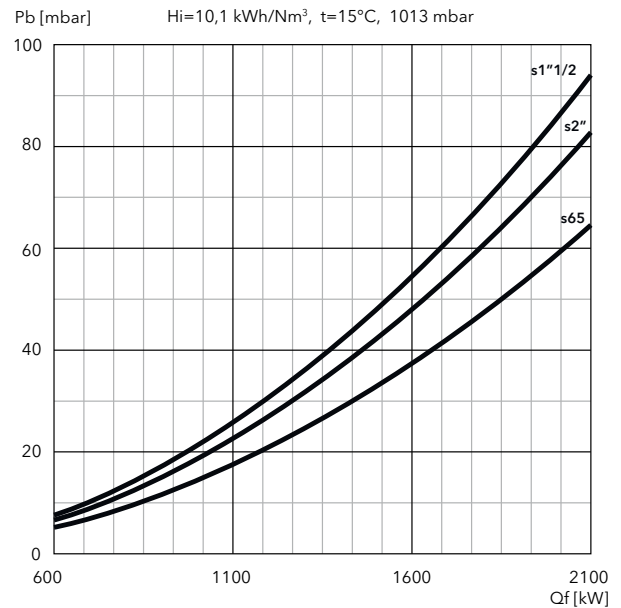

N6.2900 GL-EF3

DUNGS

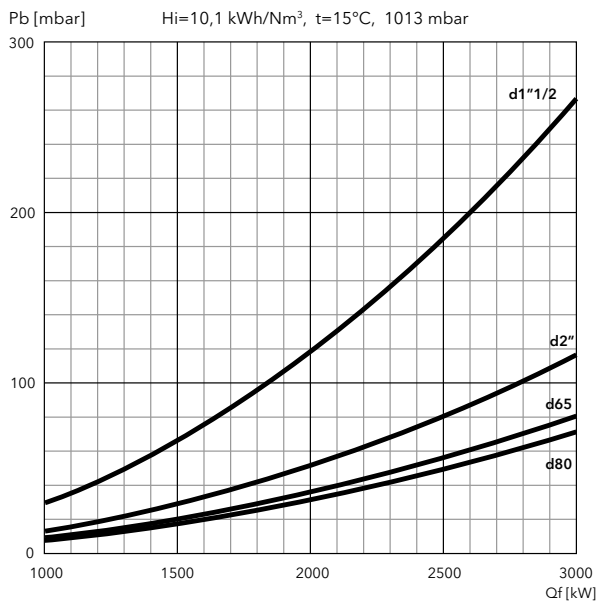

SIEMENS

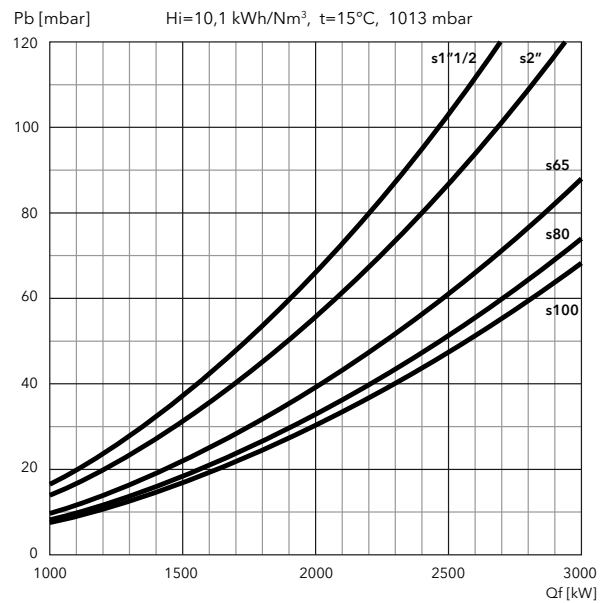

FILTERS

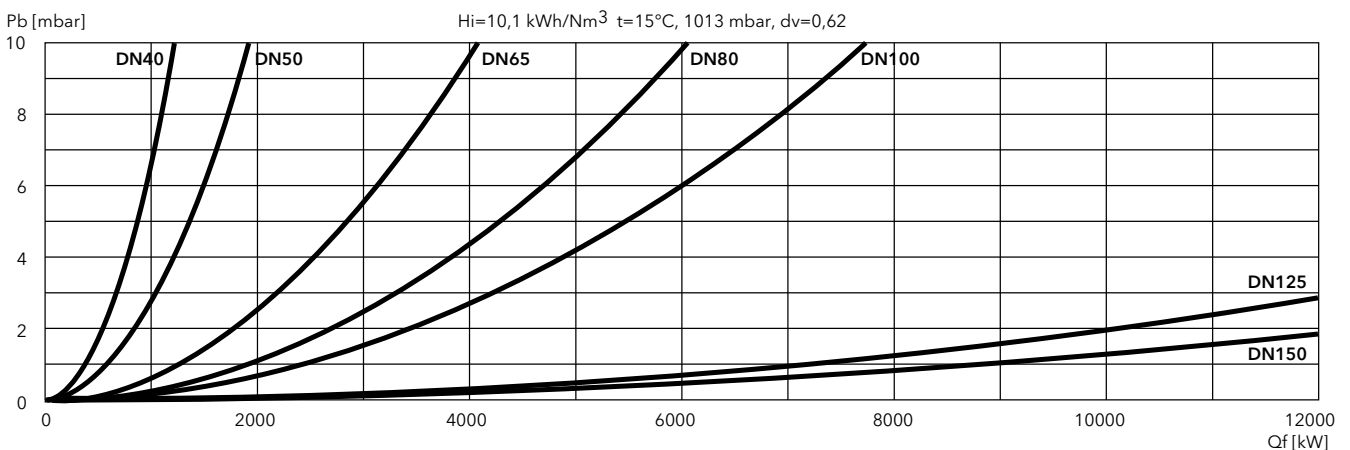

PRESSURE LOSSES (BURNER HEAD + GAS TRAIN)

N7.3600 GL-EF3

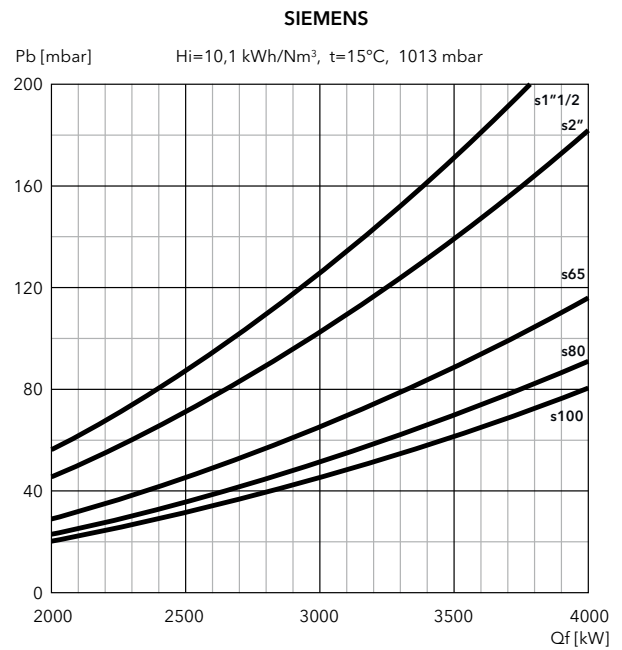
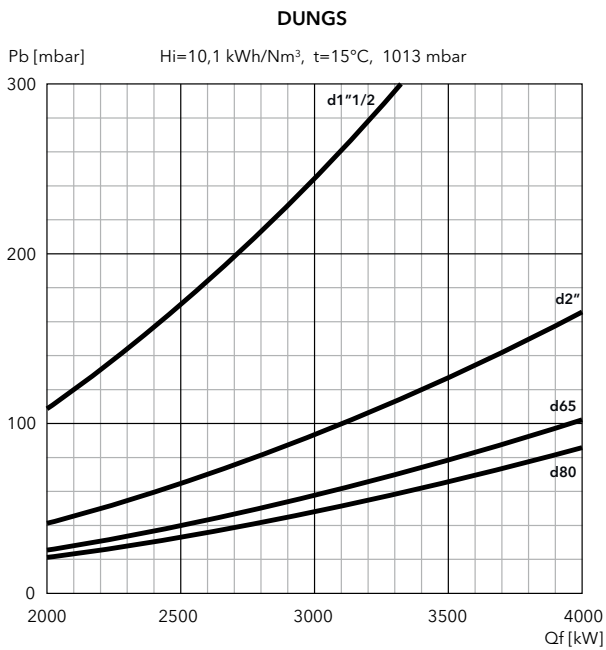

N7.4500 GL-EF3

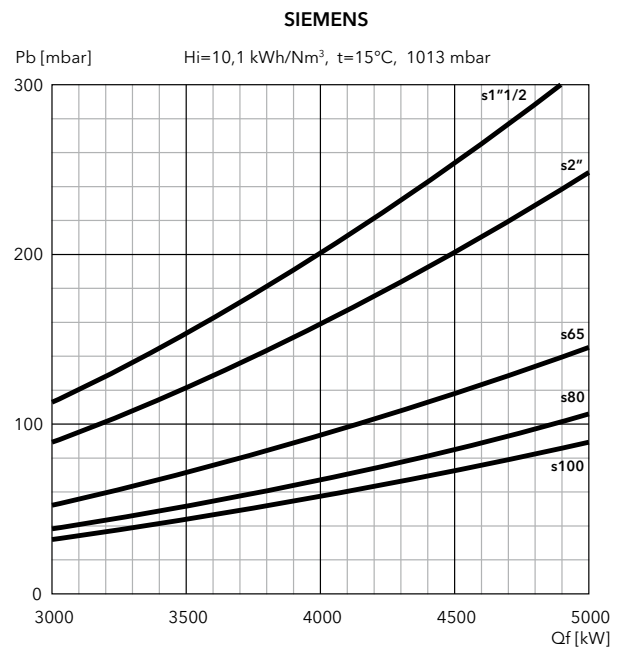
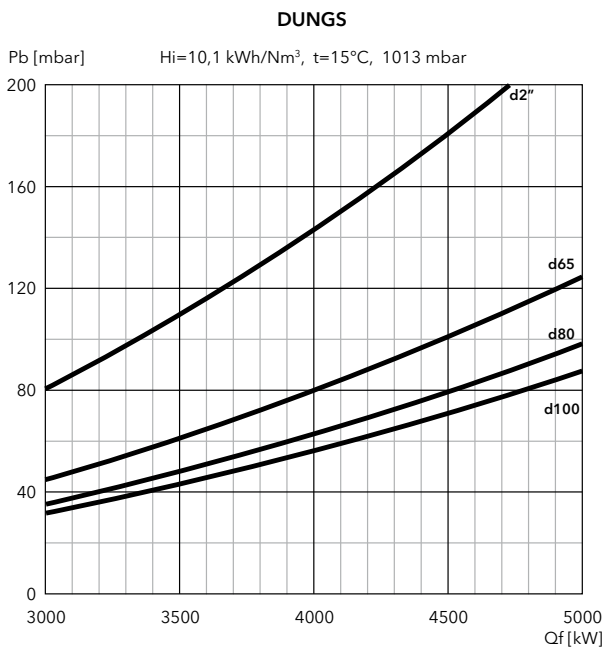

FILTERS

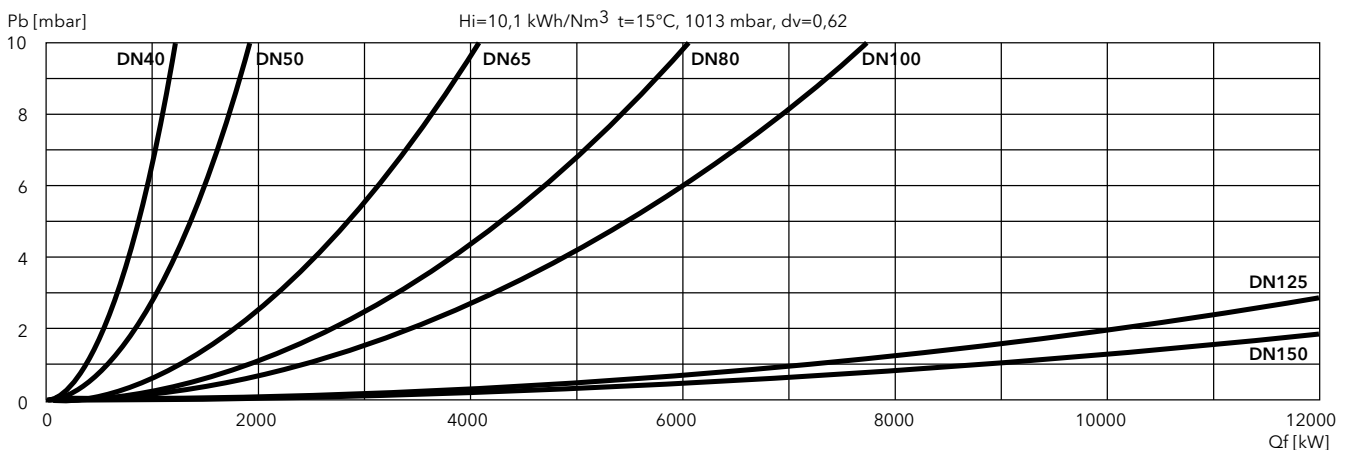

N8/N9 GL-EF3, N9 GL-EUF

830 ... 9570 kW

2 stage progressive/modulating electronic (Low NOx class 3)

- **Fuels:** natural gas, Hi = 6,99 ... 11,39 kWh/Nm³;
light oil, viscosity 6 mm²/s at 20°C, Hi = 11,86 kWh/kg
- **Emission class:** Low NOx class 3 (≤80 mg/kWh) according to EN676 in gas
Low NOx class 3 (≤120 mg/kWh) according to EN267 in light oil
- **Protection level:** IP 41



TECHNICAL DATA

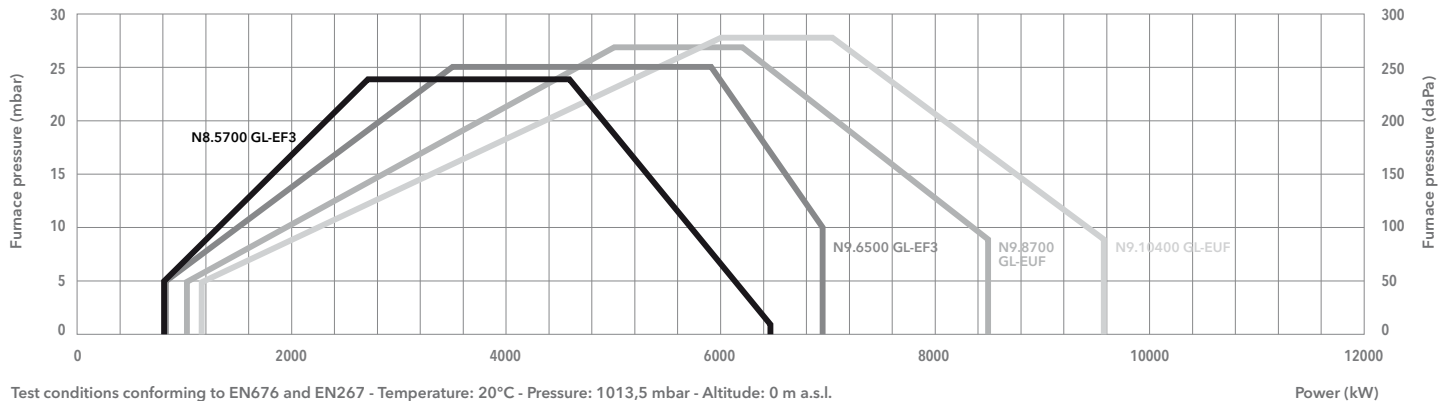

Test conditions conforming to EN676 and EN267 - Temperature: 20°C - Pressure: 1013,5 mbar - Altitude: 0 m a.s.l.

	N8.5700 GL-EF3	N9.6500 GL-EF3	N9.8700 GL-EUF	N9.10400 GL-EUF
Operating range gas	830 - 6450 kW	830 - 6950 kW	1040 - 8500 kW	1160 - 9570 kW
Operating range oil	1030 - 6450 kW	1030 - 6600 kW	1800 - 8500 kW	2550 - 9570 kW
Gas pressure	100 - 500 mbar (100 - 360 mbar for d457 gas train)		100 - 500 mbar (100 - 360 mbar for d457 gas train)	
Gas connection	DN100	DN100	DN100	DN100
Auxiliary voltage	1NPE AC 230 V - 50 Hz TN-S	1NPE AC 230 V - 50 Hz TN-S	1NPE AC 230 V - 50 Hz TN-S	1NPE AC 230 V - 50 Hz TN-S
Power supply	3PE AC 400 V - 50 Hz	3PE AC 400 V - 50 Hz	3PE AC 400 V - 50 Hz	3PE AC 400 V - 50 Hz
Control box / flame detector	BT300 / Satronic 1020	BT300 / Satronic 1020	BT300 / D-LX 100 EK-S	BT300 / D-LX 100 EK-S
Fan motor	50 Hz - 15 kW	50 Hz - 22 kW	50 Hz - 18,5 kW	50 Hz - 22 kW
Pump	SMG1630 - 1700 l/h	SMG1630 - 1700 l/h	SMG1630 - 1700 l/h	SMG1631 - 2200 l/h
Motor pump	50 Hz - 3 kW	50 Hz - 3 kW	50 Hz - 3 kW	50 Hz - 4 kW
Acoustic level	<80 dB(A)	<83 dB(A)	<81 dB(A)	<81,7 dB(A)
CE certificate	0085CL0215	0085CL0215	0085CL0215	0085CL0215
Complete burner codes	on request	on request	on request	on request

GAS TRAINS

DUNGS

Model	Code
GT-d457-2" (*)	3750515
GT-d458-65	3750516
GT-d459-80	3750517
GT-d460-100	3750518

*: integrated filter

SIEMENS

Model	Code
GT-s457-2"	3750537
GT-s458-65	3750538
GT-s459-80	3750539
GT-s460-100	3750540
GT-s461-125	3750541

FILTERS

Model	Code
FG-Rp2"	3757200
FG-DN65	3757198
FG-DN80	3757201
FG-DN100	3757195
FG-DN125	3757209

Pressure drops graphs: see following pages
Dimensions of gas trains and gas filters: see pag. 207



DIMENSIONS (mm)

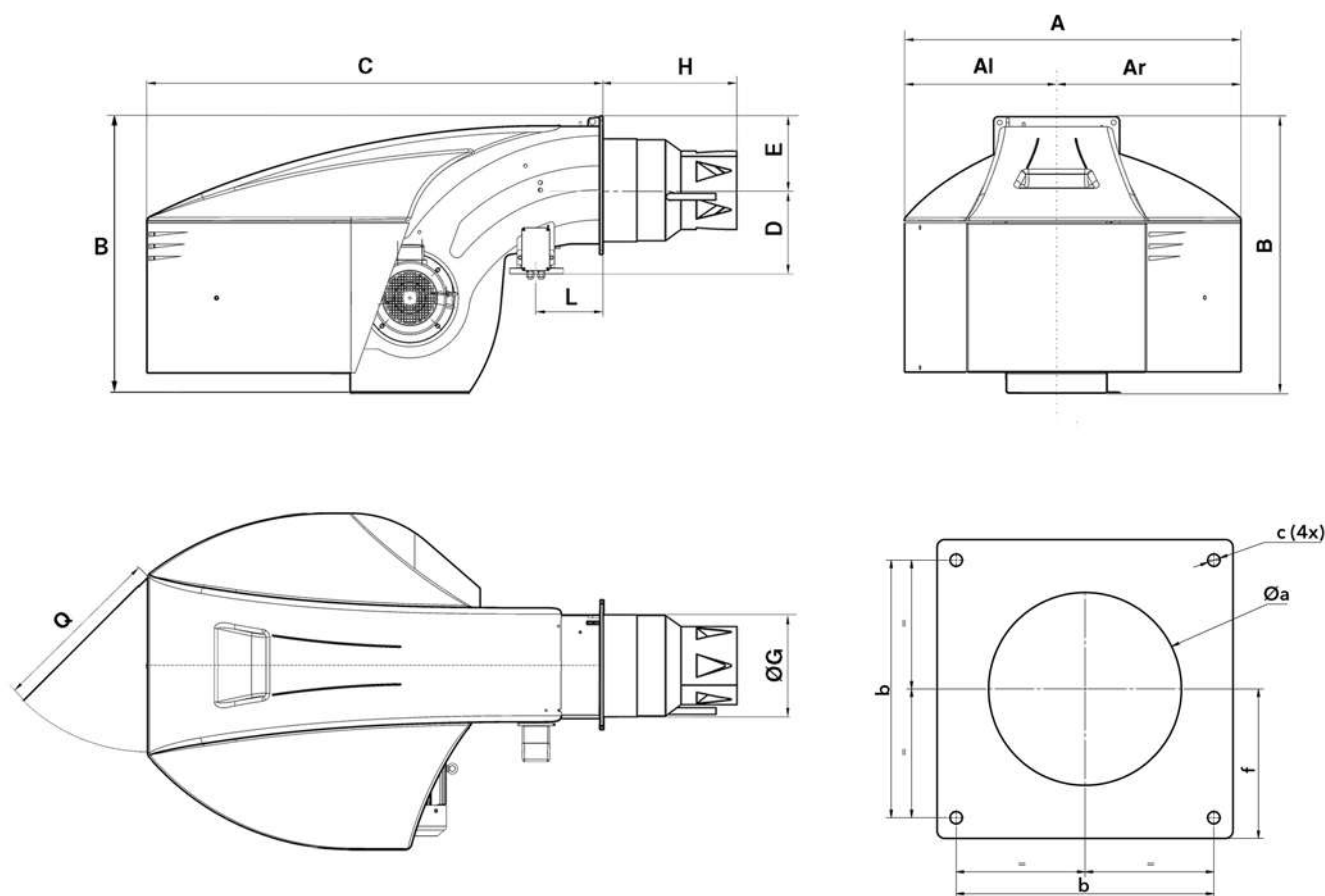

Model	A	Al	Ar	B	C	D	E	ØG	H			L	Q	Øa	b	c	f
									KN	KM	KL						
N8.5700	1414	669	745	1231	1930	391	293	369	528	668	808	230	800	380-410	505	M20	293
N9.6500	1414	669	745	1291	1928	434	293	431,5	543	693	843	230	800	445-480	505	M20	293
N9 GL-EUF	1414	669	745	1291	1928	434	293	431,5	575	725	875	230	800	445-480	505	M20	293

PACKAGING

The burner is delivered on a pallet in 2 packages containing:

- burner body with mounted combustion head, boiler fixing accessories and technical documentation;
- gas train and filter.

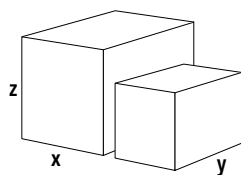

Models		Dimensions (mm)			Gross weight (kg)
		X	Y	Z	
N8.5700 GL-EF3	KN	2530	1414	1231	600
	KM	2670	1414	1231	608
	KL	2810	1414	1231	615
N9.6500 GL-EF3	KN	2550	1414	1291	670
	KM	2700	1414	1291	678
	KL	2850	1414	1291	685
N9.8700 GL-EUF	KN	2503	1414	1291	662
	KM	2653	1414	1291	670
	KL	2803	1414	1291	677
N9.10400 GL-EUF	KN	2503	1414	1291	672
	KM	2653	1414	1291	680
	KL	2803	1414	1291	687

PRESSURE LOSSES (BURNER HEAD + GAS TRAIN)

N8.5700 GL-EF3

DUNGS

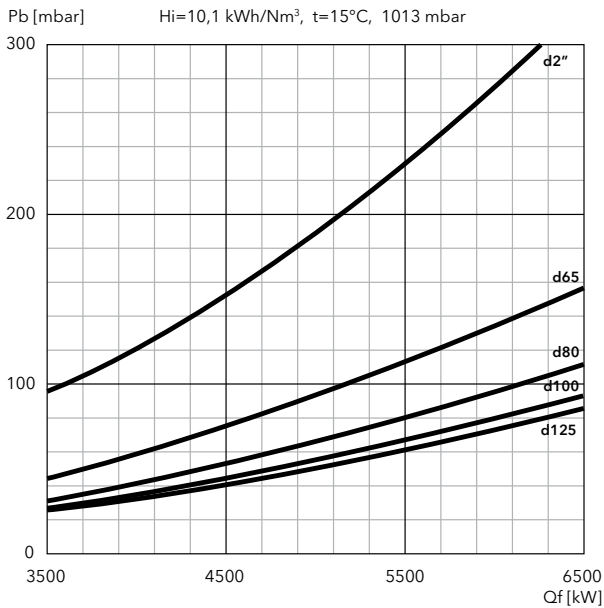

SIEMENS

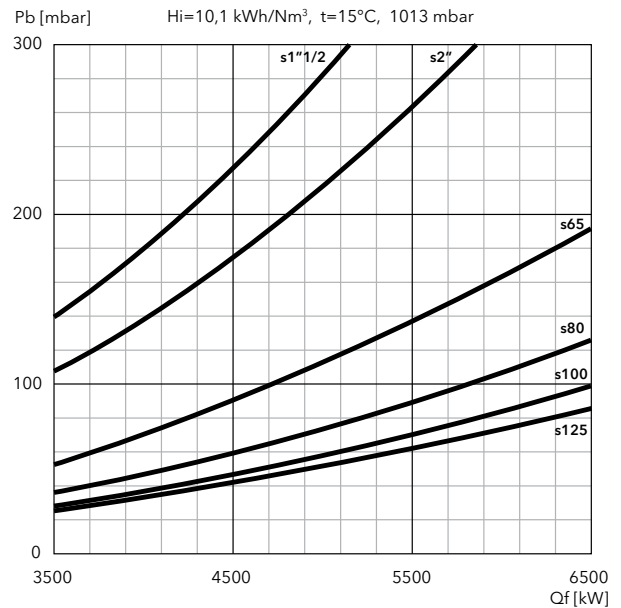

N9.6500 GL-EF3

DUNGS

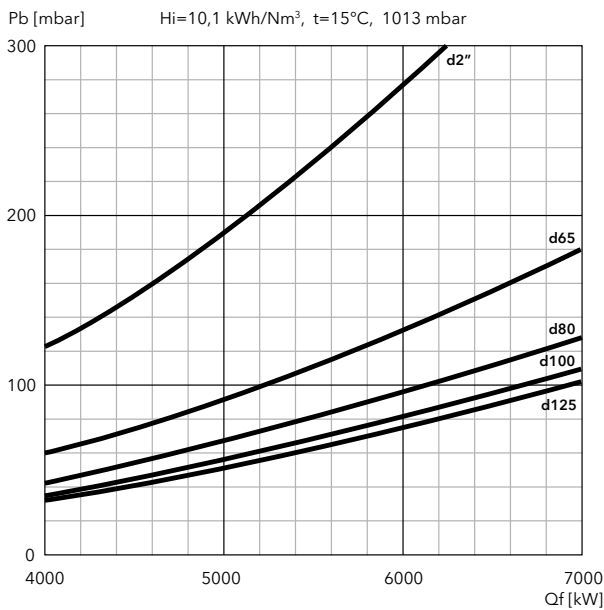

SIEMENS

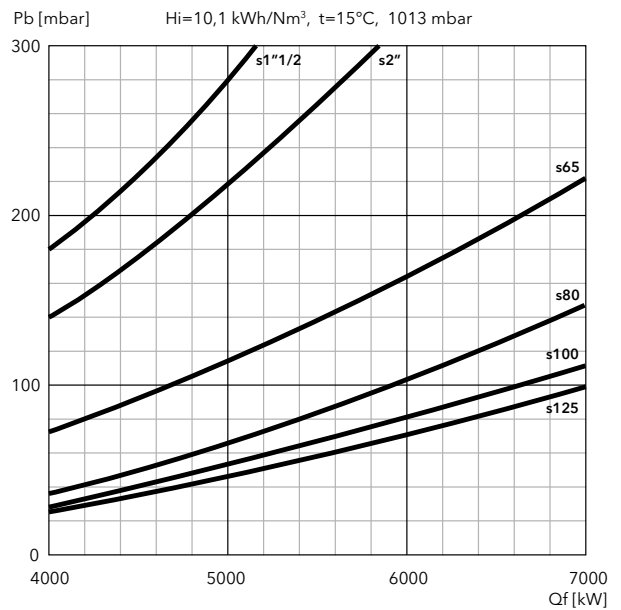

FILTERS

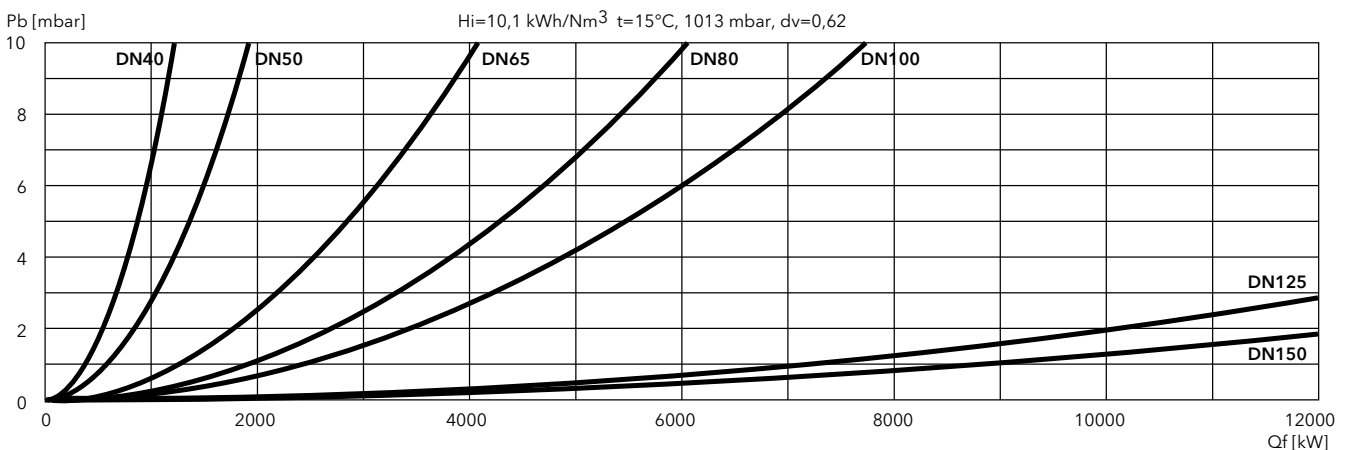

PRESSURE LOSSES (BURNER HEAD + GAS TRAIN)

N9.8700 GL-EUF

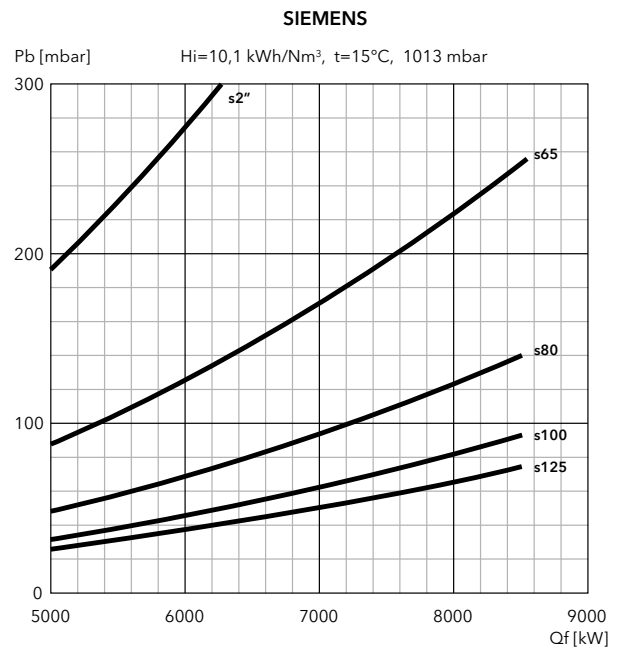
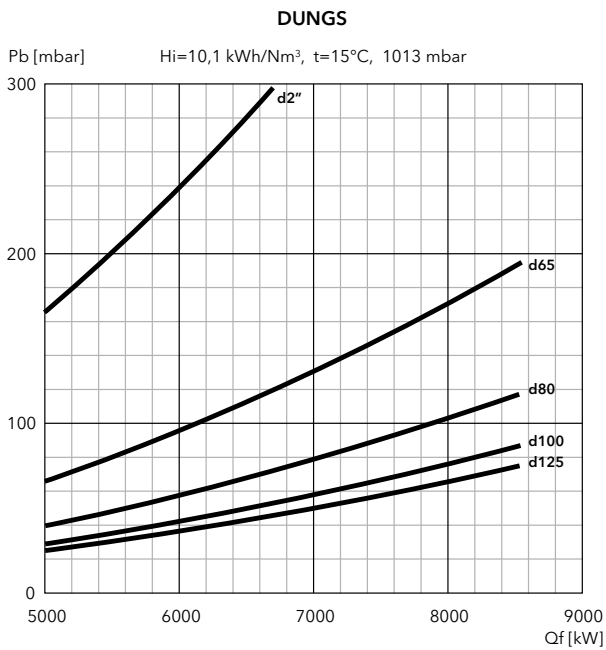

N9.10400 GL-EUF

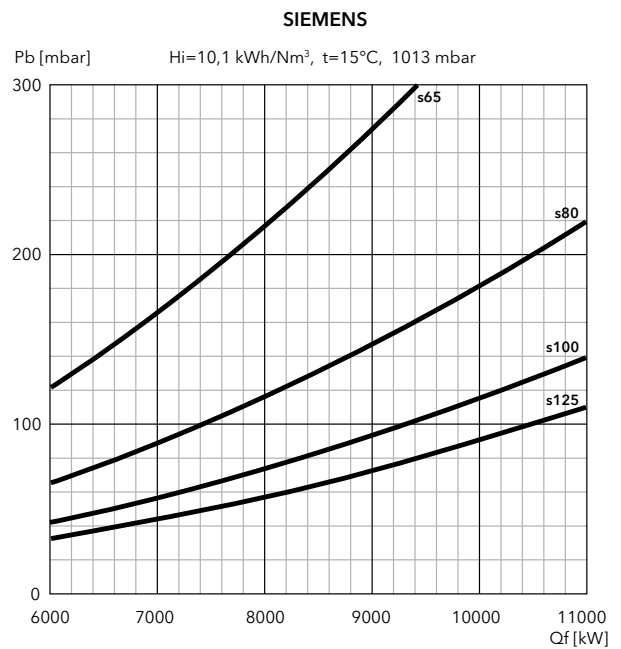
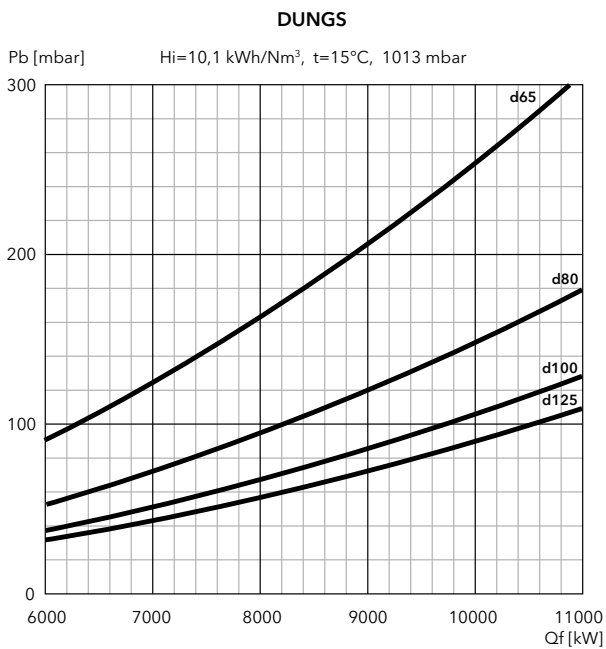

FILTERS

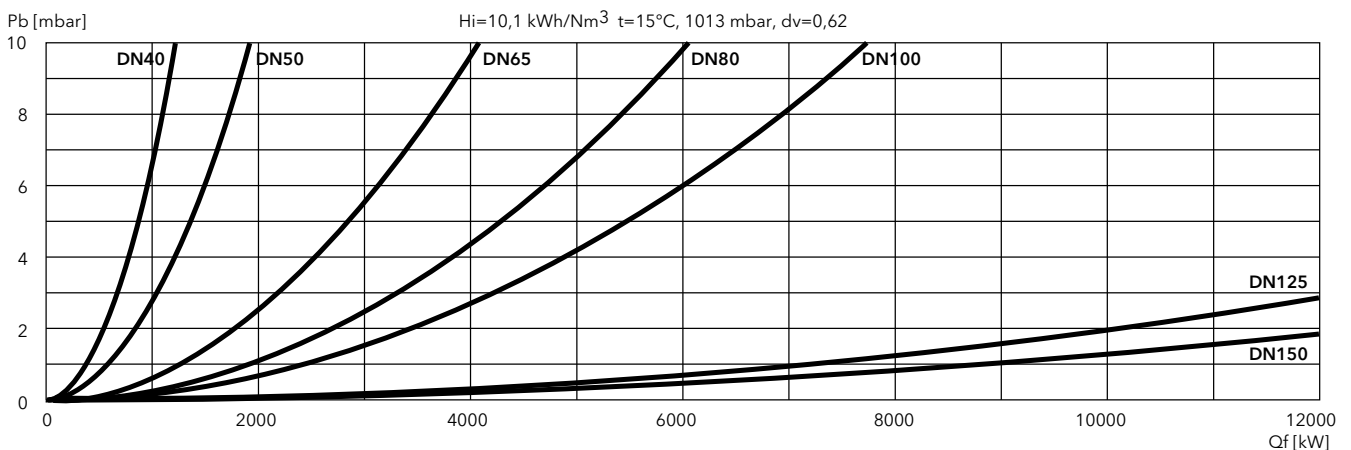

N6 L-E, N7 L-E

510 ... 4900 kW

2 stage progressive/modulating electronic

- **Fuels:** light oil, viscosity 6 mm²/s at 20°C, Hi = 11,86 kWh/kg
- **Emission class:** Low NOx class 2 (≤185 mg/kWh) according to EN267
- **Protection level:** IP 41



TECHNICAL DATA

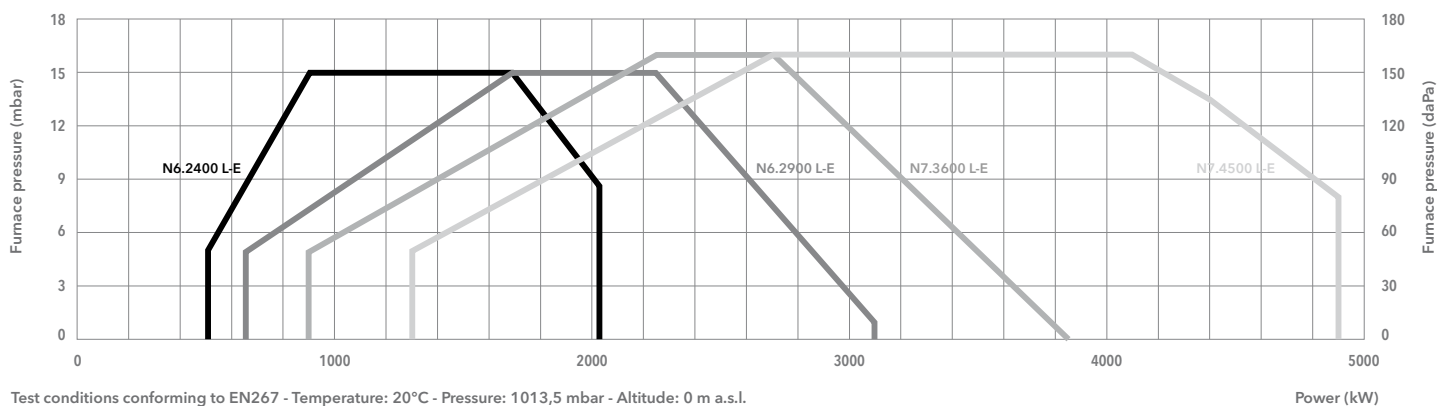

Test conditions conforming to EN267 - Temperature: 20°C - Pressure: 1013,5 mbar - Altitude: 0 m a.s.l.

	N6.2400 L-E	N6.2900 L-E	N7.3600 L-E	N7.4500 L-E
Operating range	510 - 2030 kW	650 - 3100 kW	900 - 3850 kW	1300 - 4900 kW
Fuel connection	DN20 x 1500 mm / R 1/2"	DN20 x 1500 mm / R 1/2"	DN20 x 1500 mm / R 3/4"	DN20 x 1500 mm / R 3/4"
Auxiliary voltage	1NPE AC 230 V - 50 Hz TN-S	1NPE AC 230 V - 50 Hz TN-S	1NPE AC 230 V - 50 Hz TN-S	1NPE AC 230 V - 50 Hz TN-S
Power supply	3PE AC 400 V - 50 Hz	3PE AC 400 V - 50 Hz	3PE AC 400 V - 50 Hz	3PE AC 400 V - 50 Hz
Control box / flame detector	BT300 / QRA2	BT300 / QRA2	BT300 / QRA2	BT300 / QRA2
Fan motor	50 Hz - 3 kW	50 Hz - 4 kW	50 Hz - 5,5 kW	50 Hz - 7,5 kW
Pump	SUNTEC TA3	SUNTEC TA3	SUNTEC TA4	SUNTEC TA5
Motor pump	50 Hz - 0,74 kW	50 Hz - 0,74 kW	50 Hz - 1,1 kW	50 Hz - 1,5 kW
Acoustic level	<70 dB(A)	<71 dB(A)	<74 dB(A)	<75 dB(A)
CE certificate	0085CL0215	0085CL0215	0085CL0215	0085CL0215
Complete burner codes	on request	on request	on request	on request



DIMENSIONS (mm)

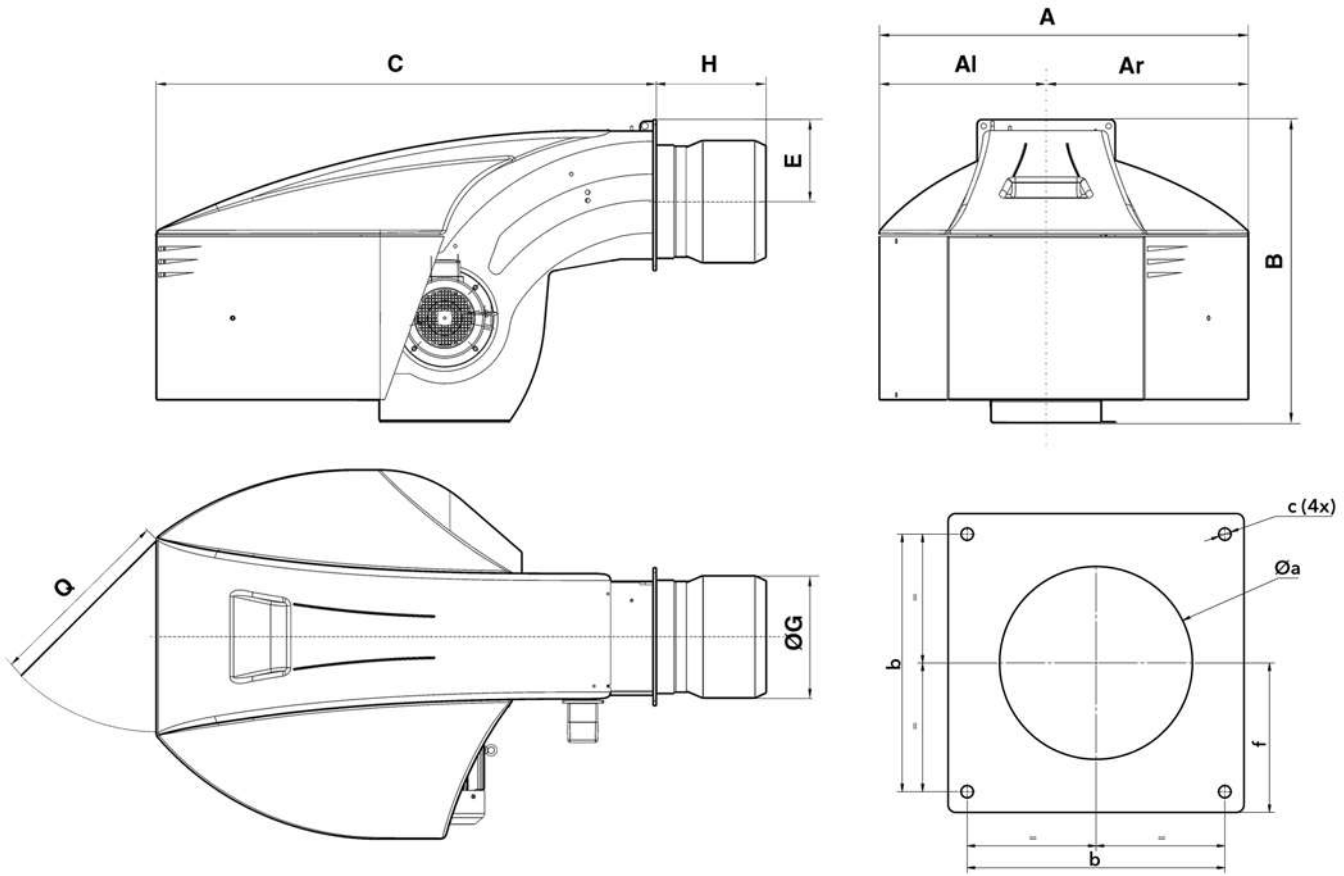

Model	A	Al	Ar	B	C	E	ØG	H			Q	Øa	b	c	f
								KN	KM	KL					
N6.2400 L-E	990	479	510	837	1361	225	290	330	450	570	600	300-340	340	M16	200
N6.2900 L-E	990	479	510	837	1361	225	310	330	450	570	600	320-340	340	M16	200
N7.3600 L-E	1128	511	618	961	1529	255	330	375	505	635	600	340-400	400	M16	235
N7.4500 L-E	1128	511	618	961	1529	255	370	375	505	635	600	380-400	400	M16	235

PACKAGING

The burner is delivered on a pallet in 1 package containing:
 • burner body with mounted combustion head, boiler fixing accessories, technical data including electrical diagram, exploded view, spare parts list, and instruction manual.

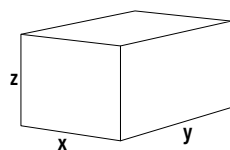

Models	Dimensions (mm)			Gross weight (kg)	
	X	Y	Z		
N6.2400 L-E	KN	1691	990	837	315
	KM	1811	990	837	315
	KL	1931	990	837	315
N6.2900 L-E	KN	1691	990	837	325
	KM	1811	990	837	325
	KL	1931	990	837	325
N7.3600 L-E	KN	1904	1128	961	360
	KM	2034	1128	961	360
	KL	2164	1128	961	360
N7.4500 L-E	KN	1904	1128	961	370
	KM	2034	1128	961	370
	KL	2164	1128	961	370

N8 L-E, N9 L-E

1350 ... 10620 kW

2 stage progressive/modulating electronic

- **Fuels:** light oil, viscosity 6 mm²/s at 20°C, Hi = 11,86 kWh/kg
- **Emission class:** Low NOx class 2 (≤185 mg/kWh) according to EN267
- **Protection level:** IP 41



TECHNICAL DATA

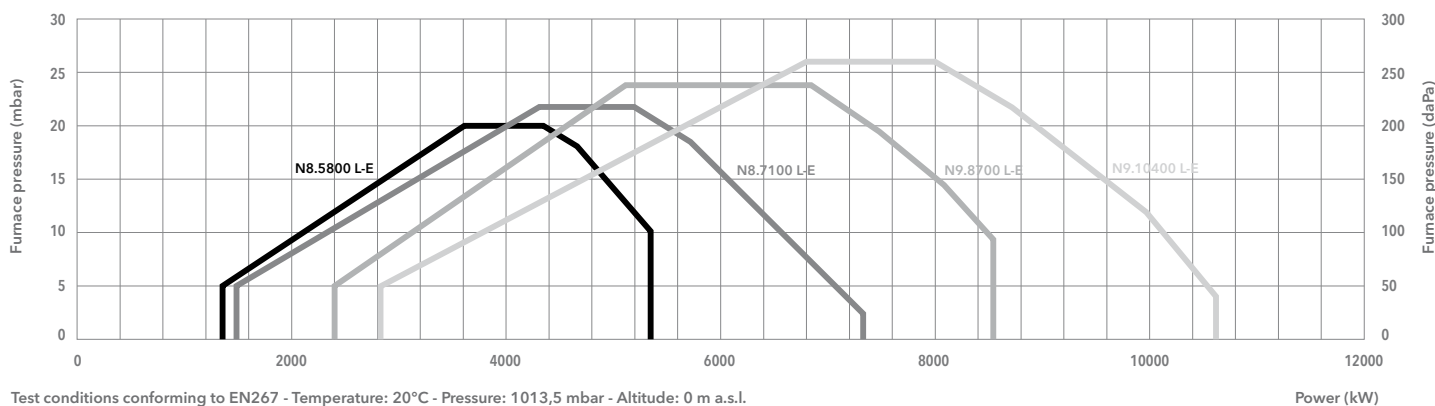

Test conditions conforming to EN267 - Temperature: 20°C - Pressure: 1013,5 mbar - Altitude: 0 m a.s.l.

Power (kW)

	N8.5800 L-E	N8.7100 L-E	N9.8700 L-E	N9.10400 L-E
Operating range	1350 - 5350 kW	1470 - 7340 kW	2400 - 8530 kW	2820 - 10620 kW
Fuel connection	DN20 x 1500 mm / R 3/4"	DN20 x 1500 mm / R 3/4"	DN25 x 1500 mm / R 1"	DN25 x 1500 mm / R 1"
Auxiliary voltage	1NPE AC 230 V - 50 Hz TN-S	1NPE AC 230 V - 50 Hz TN-S	1NPE AC 230 V - 50 Hz TN-S	1NPE AC 230 V - 50 Hz TN-S
Power supply	3PE AC 400 V - 50 Hz	3PE AC 400 V - 50 Hz	3PE AC 400 V - 50 Hz	3PE AC 400 V - 50 Hz
Control box / flame detector	BT300 / QRA2	BT300 / QRA2	BT300 / QRA2	BT300 / QRA2
Fan motor	50 Hz - 11 kW	50 Hz - 15 kW	50 Hz - 18,5 kW	50 Hz - 22 kW
Pump	SMG1630 - 1700 l/h	SMG1630 - 1700 l/h	SMG1631 - 2200 l/h	SMG1631 - 2200 l/h
Motor pump	50 Hz - 3 kW	50 Hz - 3 kW	50 Hz - 4 kW	50 Hz - 4 kW
Acoustic level	<77,4 dB(A)	<79,5 dB(A)	<81 dB(A)	<81,7 dB(A)
CE certificate	0085CL0215	0085CL0215	0085CL0215	0085CL0215
Complete burner codes	on request	on request	on request	on request



DIMENSIONS (mm)

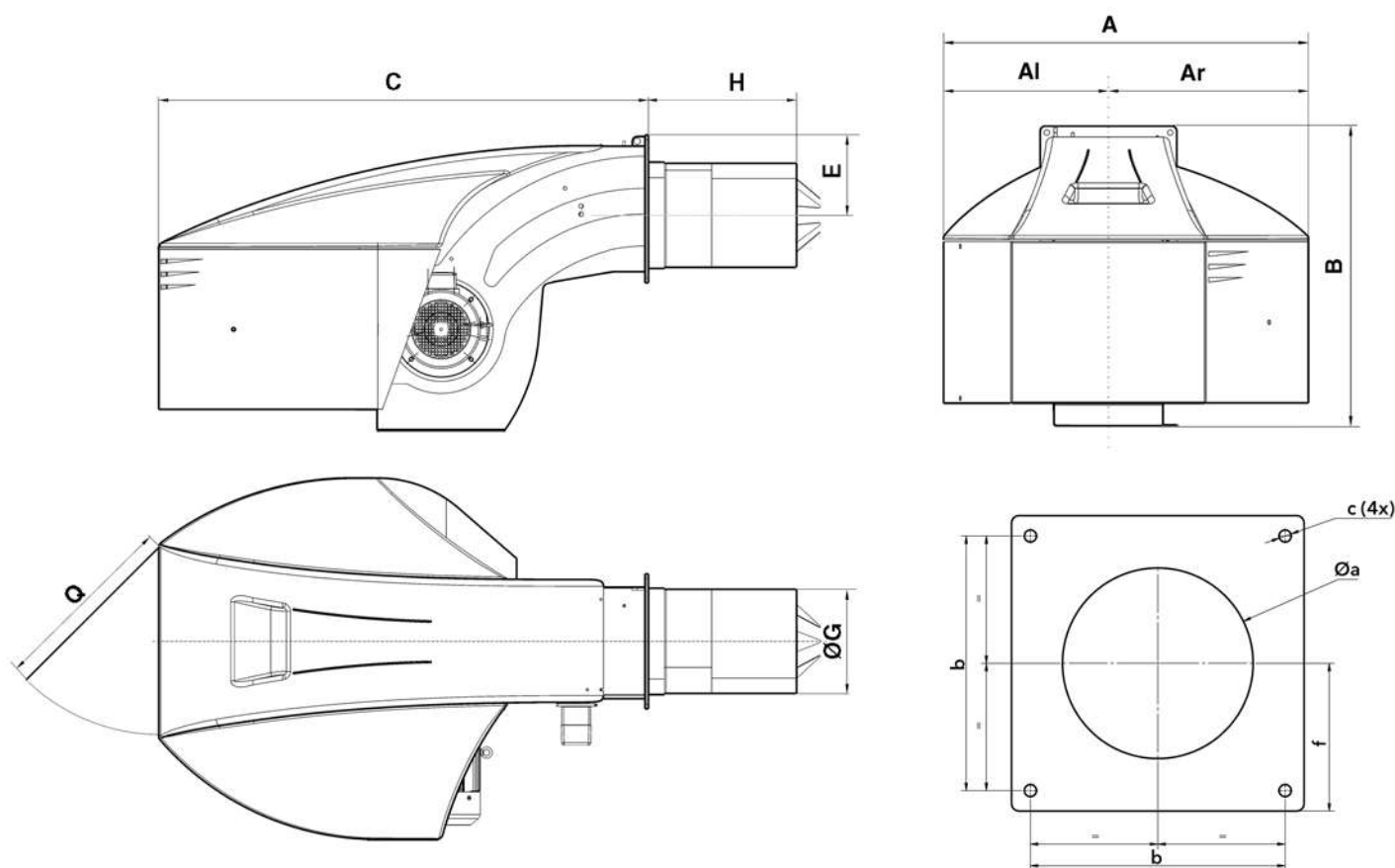

Model	A	Al	Ar	B	C	E	ØG	H			Q	Øa	b	c	f
								KN	KM	KL					
N8.5800 L-E	1414	669	745	1231	1930	293	400	562	702	842	800	430-480	505	M20	293
N8.7100 L-E	1414	669	745	1231	1930	293	415	583	723	863	800	454-480	505	M20	293
N9.8700 L-E	1414	669	745	1291	1928	293	431,5	355	505	655	800	445-480	505	M20	293
N9.10400 L-E	1414	669	745	1291	1928	293	431,5	355	505	655	800	445-480	505	M20	293

PACKAGING

The burner is delivered on a pallet in 1 package containing:
 • burner body with mounted combustion head, boiler fixing accessories, technical data including electrical diagram, exploded view, spare parts list, and instruction manual.

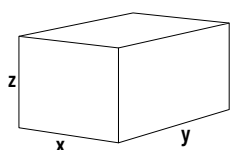

Models	Dimensions (mm)			Gross weight (kg)	
	X	Y	Z		
N8.5800 L-E	KN	2492	1414	1231	630
	KM	2632	1414	1231	637
	KL	2772	1414	1231	643
N8.7100 L-E	KN	2513	1414	1231	630
	KM	2653	1414	1231	639
	KL	2793	1414	1231	645
N9.8700 L-E	KN	2283	1414	1291	652
	KM	2433	1414	1291	660
	KL	2583	1414	1291	667
N9.10400 L-E	KN	2283	1414	1291	662
	KM	2433	1414	1291	670
	KL	2583	1414	1291	677

N6 L-EF3, N7 L-EF3

360 ... 4820 kW

2 stage progressive/modulating electronic (Low NOx class 3)

- **Fuels:** light oil, viscosity 6 mm²/s at 20°C, Hi = 11,86 kWh/kg
- **Emission class:** Low NOx class 3 (≤120 mg/kWh) according to EN267
- **Protection level:** IP 41



TECHNICAL DATA

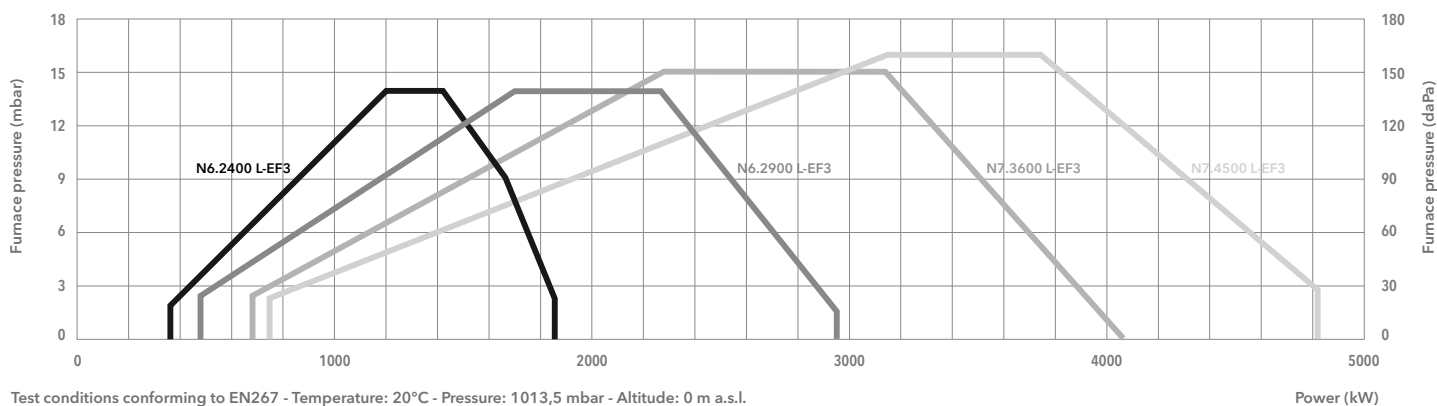

Test conditions conforming to EN267 - Temperature: 20°C - Pressure: 1013,5 mbar - Altitude: 0 m a.s.l.

	N6.2400 L-EF3	N6.2900 L-EF3	N7.3600 L-EF3	N7.4500 L-EF3
Operating range	360 - 1850 kW	480 - 2950 kW	680 - 4070 kW	740 - 4820 kW
Fuel connection	DN20 x 1500 mm / R 1/2"	DN20 x 1500 mm / R 1/2"	DN20 x 1500 mm / R 3/4"	DN20 x 1500 mm / R 3/4"
Auxiliary voltage	1NPE AC 230 V - 50 Hz TN-S	1NPE AC 230 V - 50 Hz TN-S	1NPE AC 230 V - 50 Hz TN-S	1NPE AC 230 V - 50 Hz TN-S
Power supply	3PE AC 400 V - 50 Hz	3PE AC 400 V - 50 Hz	3PE AC 400 V - 50 Hz	3PE AC 400 V - 50 Hz
Control box / flame detector	BT300 / D-LX 100 EK-S	BT300 / D-LX 100 EK-S	BT300 / D-LX 100 EK-S	BT300 / D-LX 100 EK-S
Fan motor	50 Hz - 3 kW	50 Hz - 4 kW	50 Hz - 7,5 kW	50 Hz - 7,5 kW
Pump	SUNTEC TA3	SUNTEC TA3	SUNTEC TA4	SUNTEC TA5
Motor pump	50 Hz - 0,74 kW	50 Hz - 0,74 kW	50 Hz - 1,1 kW	50 Hz - 1,5 kW
Acoustic level	<71 dB(A)	<71 dB(A)	<76 dB(A)	<74 dB(A)
CE certificate	0085CL0215	0085CL0215	0085CL0215	0085CL0215
Complete burner codes	on request	on request	on request	on request



DIMENSIONS (mm)

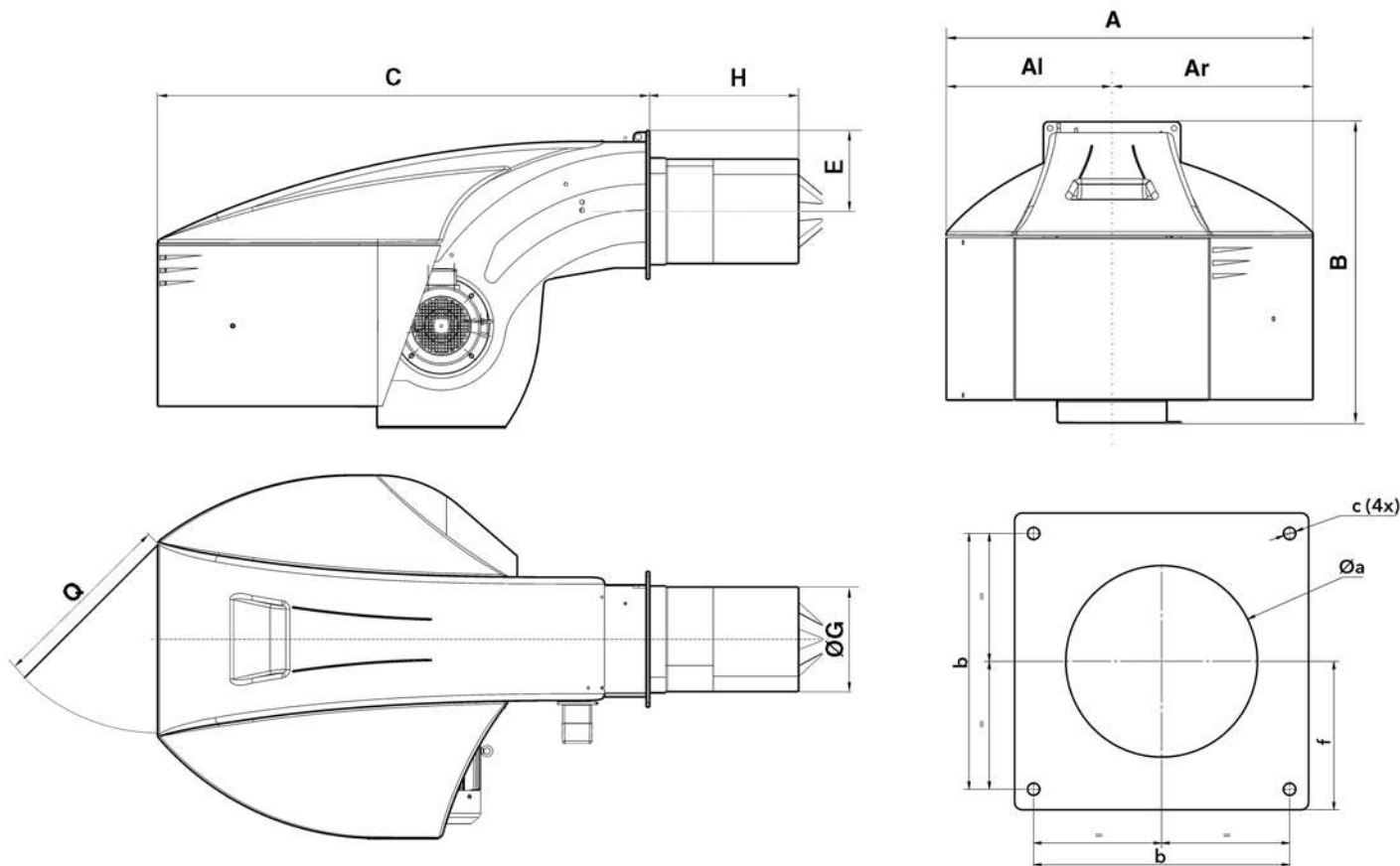

Model	A	Al	Ar	B	C	E	ØG	H			Q	Øa	b	c	f
								KN	KM	KL					
N6	990	479	510	837	1361	225	264	330	450	570	600	300-340	340	M16	200
N7	1128	511	618	961	1529	255	325	375	505	635	600	360-400	400	M16	235

PACKAGING

The burner is delivered on a pallet in 1 package containing:
 • burner body with mounted combustion head, boiler fixing accessories, technical data including electrical diagram, exploded view, spare parts list, and instruction manual.

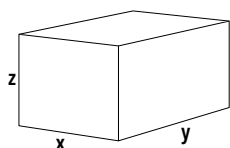

Models	Dimensions (mm)			Gross weight (kg)	
	X	Y	Z		
N6.2400 L-EF3	KN	1861	990	837	315
	KM	1981	990	837	315
	KL	2101	990	837	315
N6.2900 L-EF3	KN	1861	990	837	325
	KM	1981	990	837	325
	KL	2101	990	837	325
N7.3600 L-EF3	KN	2029	1128	961	360
	KM	2179	1128	961	360
	KL	2309	1128	961	360
N7.4500 L-EF3	KN	2029	1128	961	370
	KM	2179	1128	961	370
	KL	2309	1128	961	370

N8/N9 L-EF3, N9 L-EUF

1100 ... 9570 kW

2 stage progressive/modulating electronic (Low NOx class 3)

- **Fuels:** light oil, viscosity 6 mm²/s at 20°C, Hi = 11,86 kWh/kg
- **Emission class:** Low NOx class 3 (≤120 mg/kWh) according to EN267
- **Protection level:** IP 41



TECHNICAL DATA

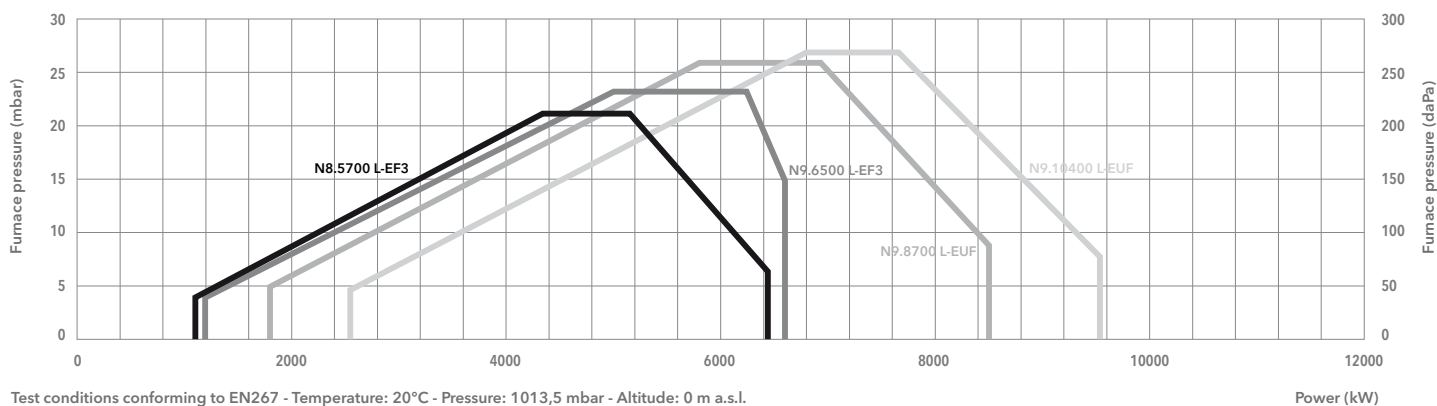

	N8.5700 L-EF3	N9.6500 L-EF3	N9.8700 L-EUF	N9.10400 L-EUF
Operating range	1100 - 6450 kW	1200 - 6600 kW	1800 - 8500 kW	2550 - 9570 kW
Fuel connection	DN20 x 1500 mm / R 3/4"	DN20 x 1500 mm / R 3/4"	DN20 x 1500 mm / R 3/4"	DN25 x 1500 mm / R 1"
Auxiliary voltage	1NPE AC 230 V - 50 Hz TN-S	1NPE AC 230 V - 50 Hz TN-S	1NPE AC 230 V - 50 Hz TN-S	1NPE AC 230 V - 50 Hz TN-S
Power supply	3PE AC 400 V - 50 Hz	3PE AC 400 V - 50 Hz	3PE AC 400 V - 50 Hz	3PE AC 400 V - 50 Hz
Control box / flame detector	BT300 / D-LX 100 EK-S	BT300 / D-LX 100 EK-S	BT300 / D-LX 100 EK-S	BT300 / D-LX 100 EK-S
Fan motor	50 Hz - 15 kW	50 Hz - 22 kW	50 Hz - 18,5 kW	50 Hz - 22 kW
Pump	SMG1630 - 1700 l/h	SMG1630 - 1700 l/h	SMG1630 - 1700 l/h	SMG1631 - 2200 l/h
Motor pump	50 Hz - 3 kW	50 Hz - 3 kW	50 Hz - 3 kW	50 Hz - 4 kW
Acoustic level	<80,2 dB(A)	<82,9 dB(A)	<81 dB(A)	<81,7 dB(A)
CE certificate	0085CL0215	0085CL0215	0085CL0215	0085CL0215
Complete burner codes	on request	on request	on request	on request



DIMENSIONS (mm)

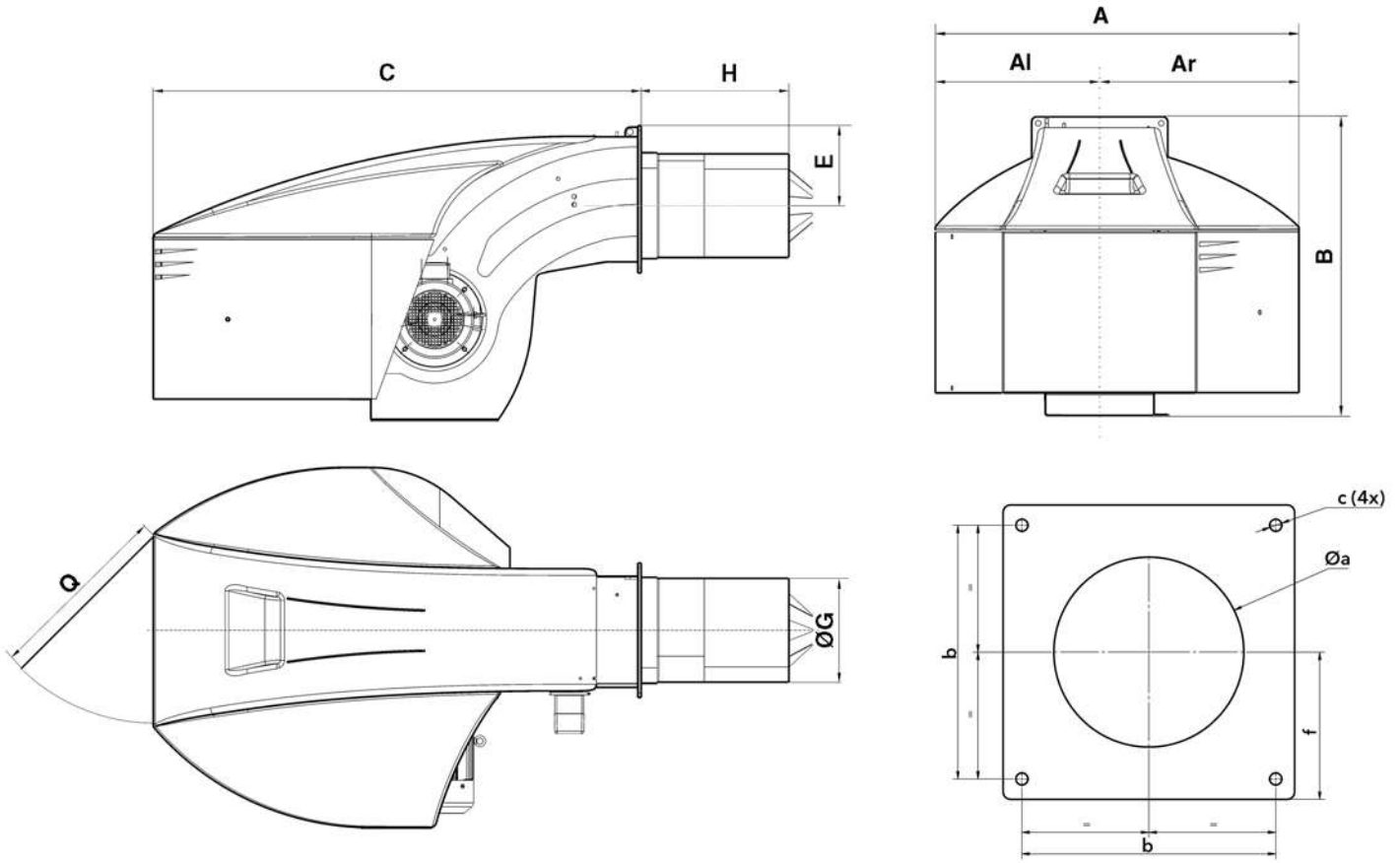

Model	A	AI	Ar	B	C	E	ØG	H			Q	Øa	b	c	f
								KN	KM	KL					
N8.5700 L-EF3	1414	669	745	1291	1928	293	369	528	668	808	800	380-410	505	M20	293
N9.6500 L-EF3	1414	669	745	1291	1928	293	431,5	543	693	843	800	445-480	505	M20	293
N9 L-EUF	1414	669	745	1291	1928	293	431,5	575	725	875	800	445-480	505	M20	293

PACKAGING

The burner is delivered on a pallet in 1 package containing:
 • burner body with mounted combustion head, boiler fixing accessories, technical data including electrical diagram, exploded view, spare parts list, and instruction manual.

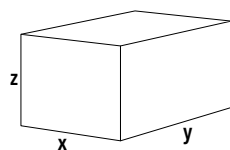

Models	Dimensions (mm)			Gross weight (kg)	
	X	Y	Z		
N8.5700 L-EF3	KN	2530	1414	1231	600
	KM	2670	1414	1231	608
	KL	2810	1414	1231	615
N9.6500 L-EF3	KN	2550	1414	1291	670
	KM	2700	1414	1291	678
	KL	2850	1414	1291	685
N9.8700 L-EUF	KN	2503	1414	1291	652
	KM	2653	1414	1291	660
	KL	2803	1414	1291	667
N9.10400 L-EUF	KN	2503	1414	1291	662
	KM	2653	1414	1291	670
	KL	2803	1414	1291	677

BURNER VARIANTS (options already mounted in factory)

LCM MODULE (for communication, O₂ control, frequency converter)

Module mounted in factory, requested for O ₂ control, Variatron and communication buses connections (the module is available also on request as a separate kit) Note: only one LCM module is necessary for these 3 options; it is already included in the GL-E.../BT3 versions	3752433
--	---------

MODULATING OPERATION

Regulator RWF55 + instruction manual Kit mounted in factory on the switch cabinet to be connected to the appropriate probe (see "BURNER KITS" session)	3752364
---	---------

FREQUENCY CONVERTER

Variatron mounted in factory inside the switch cabinet including the VSM module for the burners with BT300 control box
Note: one LCM module is required and must be ordered separately (for burners equipped with the BT300)

Frequency converter for N6.2400	3751418
Frequency converter for N6.2900	3751419
Frequency converter for N7.3600	3751420
Frequency converter for N7.4500	3751421
Frequency converter for N8.5800 G-...	3750778
Frequency converter for N8.7100 G-...	3750779
Frequency converter for N9.8700 G-...	3750780
Frequency converter for N9.10400 G-...	3750781
Frequency converter for N8.5800 GL-... and L-...	3751422
Frequency converter for N8.7100 GL-... and L-...	3751423
Frequency converter for N9.8700 GL-E and L-...	3751424
Frequency converter for N9.10400 GL-E and L-...	3751425
Frequency converter for N9.8700 GL-EUF	3751498
Frequency converter for N9.10400 GL-EUF	3751499

FREQUENCY CONVERTER ARRANGEMENT

Burner prepared to be connected to an external frequency inverter
NOTE: one LCM module is required and must be ordered separately (for burners equipped with the BT300)

N6.2400 G-... prepared for an external frequency converter of 3 kW	3751426
N6.2900 G-... prepared for an external frequency converter of 4 kW	3751427
N7.3600 G-E prepared for an external frequency converter of 5,5 kW	3751428
N7.3600 G-EF3 and N7.4500 G-E/G-EF3 prepared for an external frequency converter of 7,5 kW	3751429
N8.5800 G-E prepared for an external frequency converter of 11 kW	3751113
N8.7100 G-E prepared for an external frequency converter of 15 kW	3751114
N9.8700 G-E prepared for an external frequency converter of 18,5 kW	3751115
N9.10400 G-E prepared for an external frequency converter of 22 kW	3751116
N6 GL-... and N6 L-... prepared for an external frequency converter of 3 kW	3751430
N6 GL-... and N6 L-... prepared for an external frequency converter of 4 kW	3751431
N7 GL-... and N7 L-... prepared for an external frequency converter of 5,5 kW	3751432
N7 GL-... and N7 L-... prepared for an external frequency converter of 7,5 kW	3751433
N8 GL-... and N8 L-... prepared for an external frequency converter of 11 kW	3751434
N8 GL-... and N8 L-... prepared for an external frequency converter of 15 kW	3751435
N9.8700 GL-E and N9 L-... prepared for an external frequency converter of 18,5 kW	3751436
N9.10400 GL-E/GL-EF3 and N9 L-... prepared for an external frequency converter of 22 kW	3751437
N9.8700 GL-EUF prepared for an external frequency converter of 18,5 kW	3751500
N9.10400 GL-EUF prepared for an external frequency converter of 22 kW	3751501

BURNER VARIANTS (options already mounted in factory)

PED EQUIPMENT

Equipment of the gas train and the burner body for continuous operation (PED):

- controller and flame sensor approved for continuous operation,
- maximum gas pressure switch on the gas train,
- test burner (to bleed the gas train),
- PED Conformity Declaration.

Note: if required, the antivibrating coupling (to avoid mechanical tension) has to be selected as option

PED for N6/N7 G-E	with Siemens threaded gas trains	3750768
	with Siemens flanged gas trains	3750769
	with Dungs threaded gas trains	3750770
	with Dungs flanged gas trains	3750771
PED for N8/N9 G-E	with Siemens threaded gas trains	3751120
	with Siemens flanged gas trains	3751121
	with Dungs threaded gas trains	3751122
	with Dungs flanged gas trains	3751123
PED for N6/N7 G-EF3	with Siemens threaded gas trains	3750772
	with Siemens flanged gas trains	3750773
	with Dungs threaded gas trains	3750.873
	with Dungs flanged gas trains	3751058
PED for N6/N7 GL-E	with Siemens threaded gas trains	3751059
	with Siemens flanged gas trains	3751060
	with Dungs threaded gas trains	3751061
	with Dungs flanged gas trains	3750447
PED for N6/N7 GL-EF3	with Siemens threaded gas trains	3751062
	with Siemens flanged gas trains	3751063
	with Dungs threaded gas trains	3750450
	with Dungs flanged gas trains	3751064
PED for N8/N9 GL-E	with Siemens threaded gas trains	3751069
	with Siemens flanged gas trains	3751070
	with Dungs threaded gas trains	3751071
	with Dungs flanged gas trains	3751072
PED for N8/N9 GL-EF3	with Siemens threaded gas trains	3750460
	with Siemens flanged gas trains	3751073
	with Dungs threaded gas trains	3751074
	with Dungs flanged gas trains	3751075
PED for N6...N9 G-... and GL-... with terminal block switch cabinet	with Siemens threaded gas trains	3750764
	with Siemens flanged gas trains	3750765
	with Dungs threaded gas trains	3750766
	with Dungs flanged gas trains	3750767
PED for N6/N7 L-E		3751065
PED for N6/N7 L-EF3		3751066
PED for N8/N9 L-E		3751067
PED for N8/N9 L-EF3		3751068

BURNER VARIANTS (options already mounted in factory)

MAX GAS PRESSURE SWITCH (mounted on the gas train)

N6/N7 G-E.../GL-E...	with Siemens threaded gas trains	3751088
	with Siemens flanged gas trains	3751089
	with Dungs threaded gas trains	3751090
	with Dungs flanged gas trains	3751091
N8/N9 G-E.../GL-E...	with Siemens threaded gas trains	3751124
	with Siemens flanged gas trains	3751125
	with Dungs threaded gas trains	3751126
	with Dungs flanged gas trains	3751127
N6...N9 G-E.../GL-E... with terminal block switch cabinet	with Siemens threaded gas trains	3751076
	with Siemens flanged gas trains	3751077
	with Dungs threaded gas trains	3751078
	with Dungs flanged gas trains	3751079

STAR/DELTA MOTOR STARTER

Star/Delta 3,0 G/BT3 for N6.2400	3751414
Star/Delta 4,0 G/BT3 for N6.2900	3751415
Star/Delta 5,5 G/BT3 for N7.3600	3751416
Star/Delta 7,5 G/BT3 for N7.4500	3751417

BLIND DOOR

Door of the switch cabinet without any component. The switches and the power regulator (if required) are mounted inside the switch cabinet

For N6/N7 in gas and light oil operation	3751411
For N6/N7 in dual fuel operation	3751412
For N8/N9 in gas and light oil operation	3751119
For N8/N9 in dual fuel operation	3751413

REMOTE SIGNAL 4-20 mA

Remote signal 4-20 mA for BT300 burner variant (Note: one LCM module is required for burners equipped with BT3xx)	14099397
--	----------

BURNER KITS (delivered separately)

O₂ TRIM for BT300, Etamatic and Etamatic OEM

This device optimizes the combustion in order to keep the air excess as much stable as possible irrespective of the changings that can occur during operations, for instance slight calorific value variations, combustion air temperature and pressure. This improves the seasonal efficiency and therefore reduces the fuel consumption.

The kit includes all the fittings for the installation. Main components are:

- control unit with display;
- probe;
- intake pipe to be fixed to the stack (choose the proper length).

The control unit has to be installed close to the probe (max 20 m of cable)

The probe needs a calibration but no reference gas is necessary.

The display shows the O₂ content.

Maximum distance between the control unit and the burner control panel is 500 m.

	Output	Probe length	Code
Kit for O₂ trim (LT3 + LS2) - Flue temp max 300 °C - display for O₂ visualization (Note: for models equipped with BT3xx this kit needs a LCM module installed in the burner control panel)	1 x 4-20 mA	150 mm	3757433
	1 x 4-20 mA	300 mm	3757137
	1 x 4-20 mA	450 mm	3757138

O₂ TRIM with CO measure for BT300, Etamatic and Etamatic OEM

This device optimizes the combustion in order to keep the air excess as low as possible in order to maximize the seasonal efficiency and therefore minimize the fuel consumption.

In addition to the features of the O₂ trim only, this kit reduces the air excess to its minimum because this system continuously measures the CO content in the flue: should the air excess be reduced too much, the CO raises and the system reacts by increasing the air excess in order to keep firing in safe conditions.

The kit includes all the fittings for the installation. Main components are:

- control unit with display;
- probe;
- intake pipe to be fixed to the stack (choose the proper length).

The control unit has to be installed close to the probe (max 20 m of cable).

The probe needs a calibration but no reference gas is necessary.

The display shows the O₂ content.

Maximum distance between the control unit and the burner control panel is 500 m.

Note: this system is not suitable for GL-EUF and L-EUF burners

	Output	Probe length	Code
Kit for O₂ trim and CO control (LT3-F + KS1D) - Flue temp max 300 °C (Note: for models equipped with BT3xx this kit needs a LCM module installed in the burner control panel)	None	150 mm	3758001
	None	300 mm	3755046
	None	450 mm	3756533
	4 x 0/4-20mA	300 mm	3754549
	4 x 0/4-20mA	450 mm	3754550
	4 x 0/4-20mA & 4 x digital	300 mm	3754551
	4 x 0/4-20mA & 4 x digital	450 mm	3754552

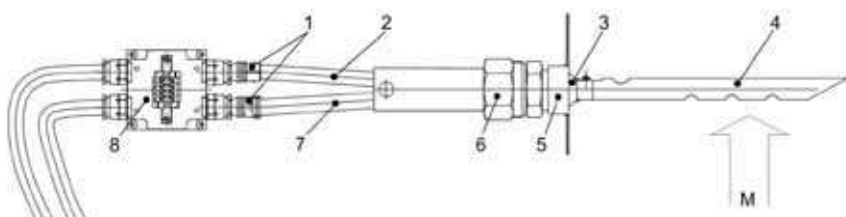

- M - measuring gas 300°C max
- 1 - plug
- 2 - probe signal
- 3 - Lambda Probe
- 4 - gas extraction device (GED)
- 5 - half-collar R1"1/4
- 6 - probe installation fitting (PIF)
- 7 - probe heater
- 8 - probe connection box (PCB)

BURNER KITS (delivered separately)

REMOTE SOFTWARE

Kit to connect a PC laptop to the BT300 for its parametrization	LSA100 + USB/CAN + CD-Rom	3751130
---	---------------------------	---------

COMMUNICATION MODULES

Module for external installation Note: one LCM module is required	ModBus/BT3	on request
	ProfiBus/BT3	3752986
	Ethernet/BT3	on request

POWER REGULATOR

Power regulator RWF55 stand-alone and kit wiring	on request
--	------------

PROBES

Immersion probes	130°C + pocket tube	3750070
	Pt 100 - 400°C (160 mm)	1758574269
	Pt 100 - 480°C (250 mm)	3751009
Pressure probes	0...1,6 bar	3752217
	0...2,5 bar	1758713722
	0...6 bar	1758640660
	0...10 bar	1758577280
	0...16 bar	1758577291
	0...25 bar	3751015

COUNTER FACE PLATE

CP11	for N6	3833908
CP12	for N7	3833909
CP13	for N8	3833910
CP14	for N9	3833911

SEALS AND CONNECTING KIT

DN40	3751040
DN50	3751041
DN65	3751042
DN80	3751043
DN100	3751044
DN125	3751045
DN150	3751046

SPECIAL CONFIGURATIONS (on request)

- Equipment according EN746-2
- Permanent ventilation
- 60 Hz versions
- Remote display (BT3xx)
- Separate switch box / terminal strip version (Etamatic OEM)
- LPG firing
- Hinge flange
- "Burner ON" feedback signal

Other special requests can be submitted to your Sales Reference for feasibility evaluation

Monoblock burners from 1300 to 22000 kW

Gas, light oil and dual fuel

High power and ease of use up to 22 MW

Wherever a compact solution is needed, a monoblock burner offers advantages over individual components. However, above a power output of 10 MW, the conventional burner becomes too heavy: ease of handling during installation and maintenance work suffers, the strain on the boiler door is too high. N burner solves this problem with innovative, weight-saving enclosure technology. The key feature is the physical division of the burner into a support frame and a separate air-routing housing. Thanks to its innovative solutions N range provides high performance and ease of use up to 22 MW.



Load distribution and reduced weight

N10 is characterised by a chassis frame mounted directly on the door of the generator; this independently supports the fan and motor assembly, which constitutes a large proportion of the total weight of the burner. This structure significantly reduces the torque generated by the motor and, consequently, reduces the strain on the boiler door. The choice of materials has been dictated by the need to reduce weight: as a result, the combustion air inlet is made of composite materials, and the air register flaps in aluminium.

Simplified structure to improve usability

The burner head and the housing have been almost entirely separated in order to allow sufficient space for the combustion components to be easily removed. The air pipe between the housing and the burner head is simply closed by a removable cover. It is no longer necessary to pivot the entire body of the burner to one side or the other. An added advantage is the ability to fix the frame to the ground, depending on the application, thus relieving the generator door from any mechanical stress.



Advanced design for low noise levels

Special attention has been paid to fan design. The burner's acoustic level meets industry standards, providing a more comfortable working environment. The two main characteristics which limit the noise emitted by a fan are a high and constant static pressure and the use of a wheel with rearward facing blades. The result is a stable combustion and reduced noise at the air inlet.

MAIN TECHNICAL FEATURES

- Two stage progressive/modulating forced draught burner
- Fuels:
 - natural gas, Hi = 6,99 ... 11,39 kWh/Nm³
 - light oil, viscosity 6 mm²/s at 20°C, Hi = 11,86 kWh/kg
- Combustion technology:
 - Low NOx class 2 (≤120 mg/kWh) and class 3 (≤80 mg/kWh) in gas operation according to EN676
 - Low NOx class 2 (≤185 mg/kWh) and class 3 (≤120 mg/kWh) in light oil operation according to EN267
- Control box: built-in (Etamatic OEM control box installed inside the junction box) or external, according to customer requirements
- Three flame tube lengths available
- Secured burner head adjustments during maintenance (RTC System)
- Closing of the air damper on burner shut-down
- Multiple gas train matching according to the inlet gas pressure
- Gas train factory assembled and tested for tightness and electrical security
- Products are in compliance with EN676 and EN267 European standards and with the following directives:
 - 2014/35/UE Low Voltage Directive
 - 2014/30/UE EMC Directive
 - 2016/426/UE Gas Appliances Regulation
 - 2006/42/EC Machinery Directive
 - 2011/65/EU RoHS2 Directive

RANGE OVERVIEW

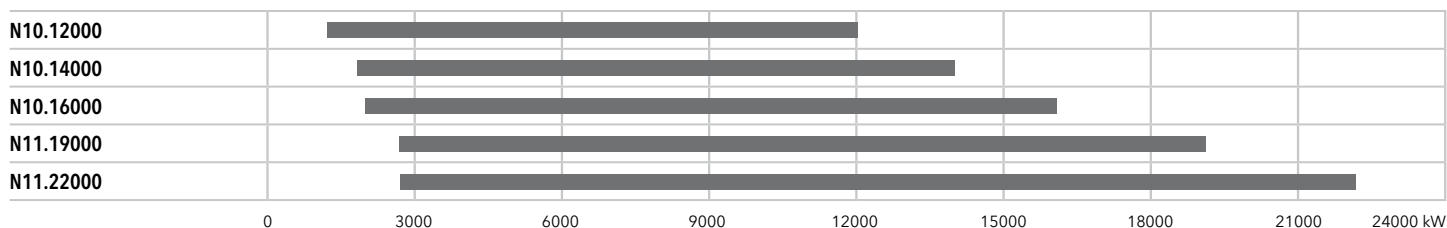

N10 G-E

1300 ... 16000 kW

2 stage progressive/modulating electronic

- **Fuels:** natural gas, Hi = 6,99 ... 11,39 kWh/m³
- **Emission class:** Low NOx class 2 (≤120 mg/kWh) according to EN676
- **Protection level:** IP 41 (IP 54 as option)



TECHNICAL DATA

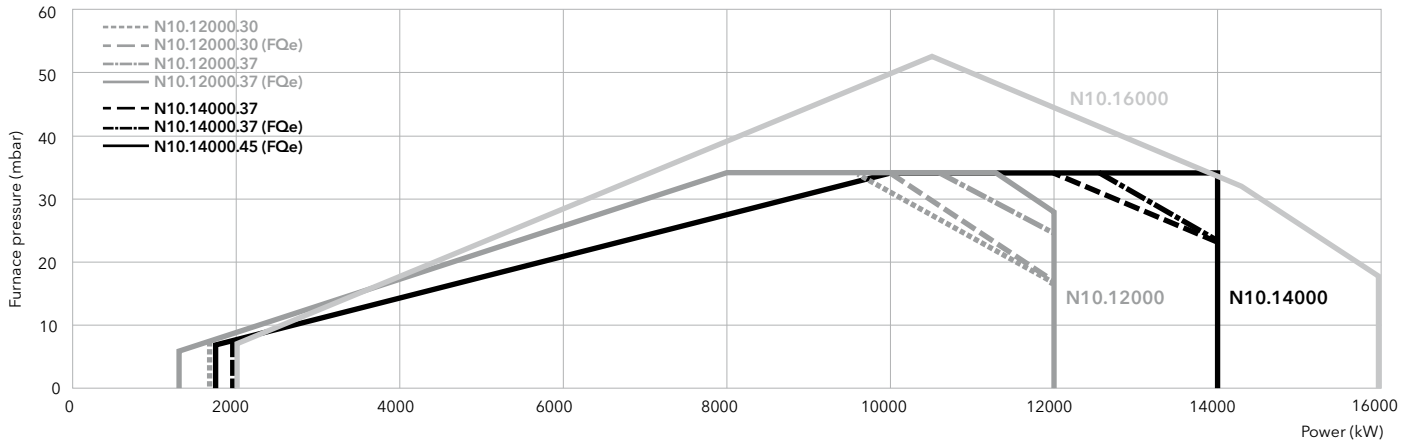

FQe = external frequency converter

	N10.12000.30 G-E	N10.12000.37 G-E	N10.14000.37 G-E	N10.14000.45 G-E	N10.16000.45 G-E
Operating range	1300* - 12000 kW (*: 1750 without FQe)	1300* - 12000 kW (*: 1750 without FQe)	1750* - 14000 kW (*: 2000 without FQe)	1750 - 14000 kW* (*: with FQe)	2000 - 16000 kW* (*: with FQe)
Gas connection	DN100	DN100	DN100	DN100	DN100
Fan motor	50/60 Hz - 30 kW	50/60 Hz - 37 kW	50/60 Hz - 37 kW	50/60 Hz - 45 kW	50/60 Hz - 45 kW
Acoustic level	< 97 dB(A)	< 97 dB(A)	< 97 dB(A)	< 97 dB(A)	< 97 dB(A)
Complete burner code	on request	on request	on request	on request	on request

GAS TRAINS

DUNGS

Model	Code
d80	on request
d100	on request
d125	on request

SIEMENS

Model	Code
s80	3757394
s100	3757395
s125	3757396
s150	3757397

FILTERS

Model	Code
FG-DN80	3757201
FG-DN100	3757195
FG-DN125	3757209
FG-DN150	3757210

 **Pressure drops graphs:** see following pages
Dimensions of gas trains and gas filters: see pag.202



DIMENSIONS (mm)

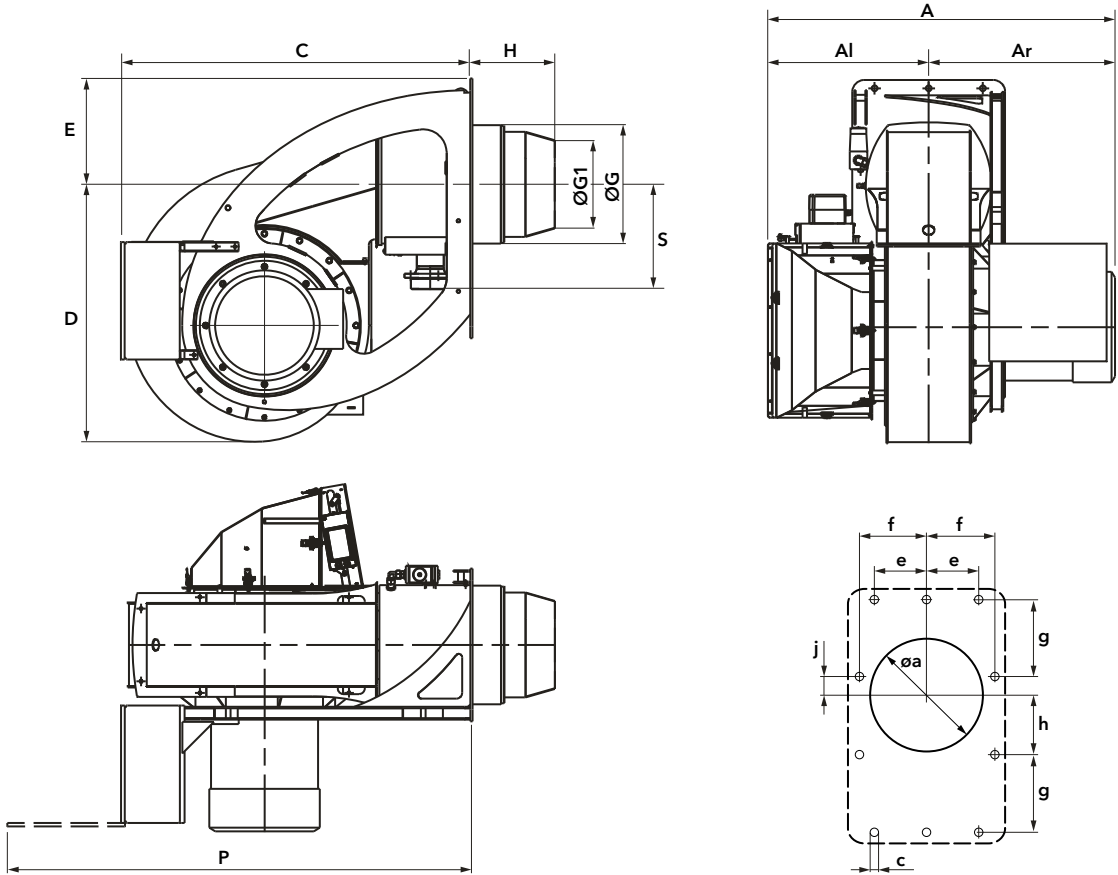

Model	A	Al	Ar	C	D	E	ØG	ØG1	H			P	S	Øa	c	e	f	g	h	j
									KN	KM	KL									
N10 G-E	1480	685	795	1500	1095	450	504	369	350	450	550	1980	446	525	M20	230	290	345	275	70

PACKAGING

- The complete burner is delivered on a pallet with:
- 1 carton box for gas train and filter
 - 1 carton box for boiler fixing accessories
 - 1 bag with technical documentation

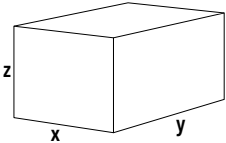

Models	Dimensions (mm)			Gross weight (kg)
	X	Y	Z	
N10 G-E	1505	2125	1545	550 (+100 for transport rack)

PRESSURE LOSSES (BURNER HEAD + GAS TRAIN)

N10.12000 G-E

DUNGS

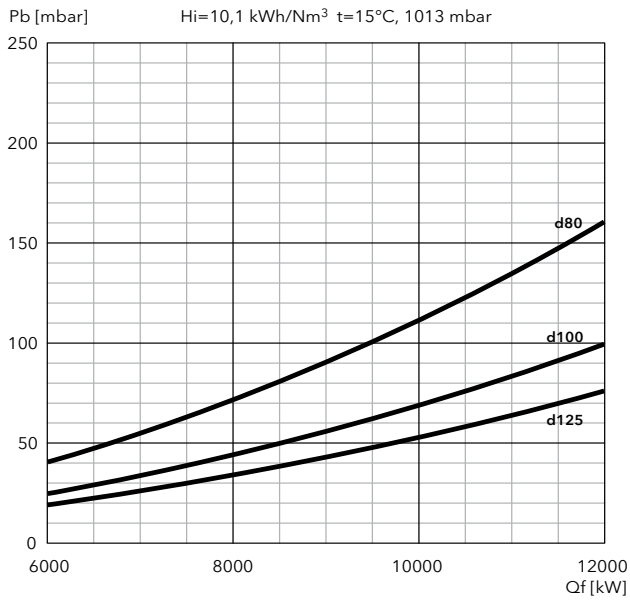

SIEMENS

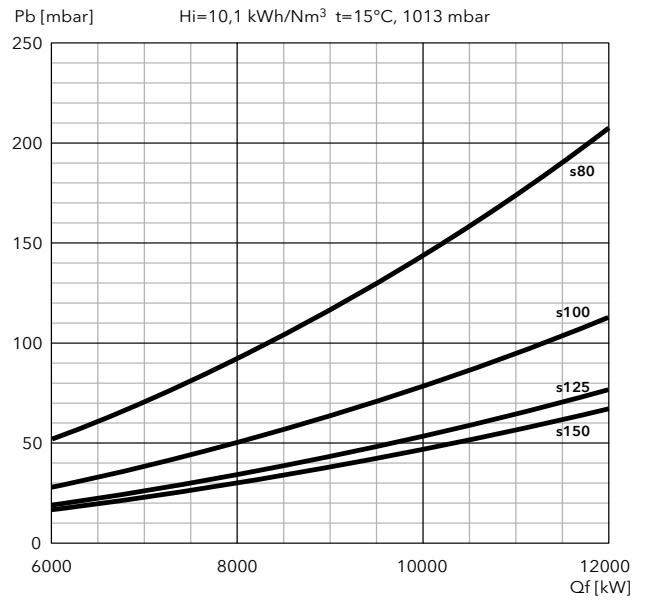

N10.14000 G-E

DUNGS

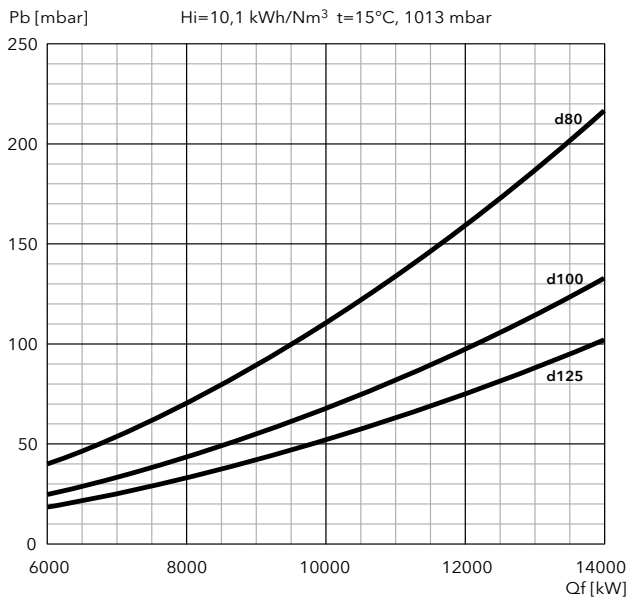

SIEMENS

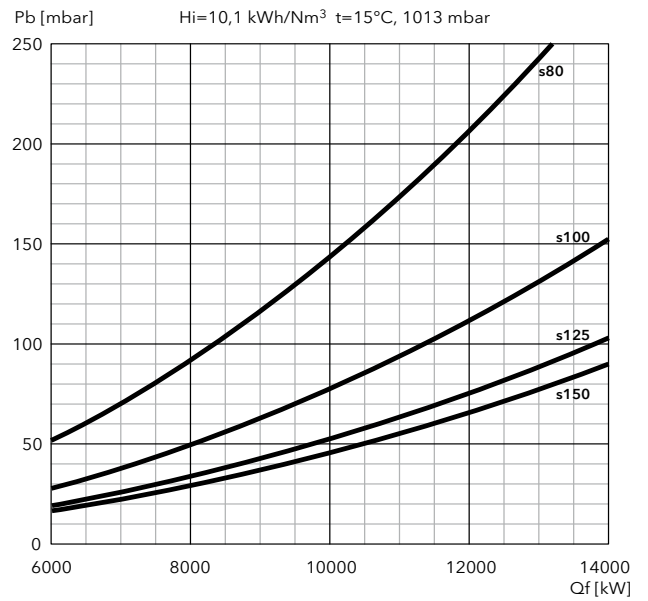

PRESSURE LOSSES (BURNER HEAD + GAS TRAIN)

N10.16000 G-E

DUNGS

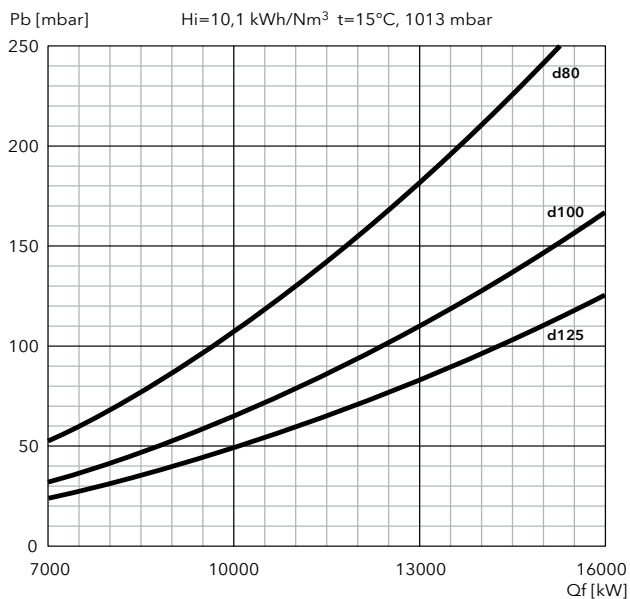

SIEMENS

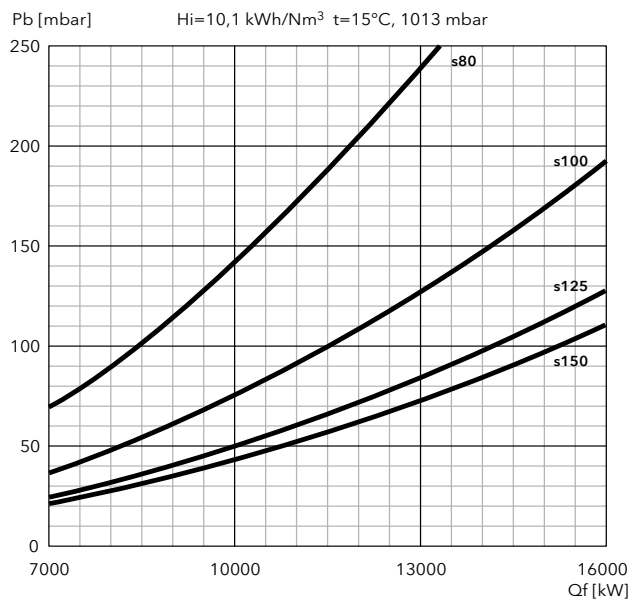

FILTERS

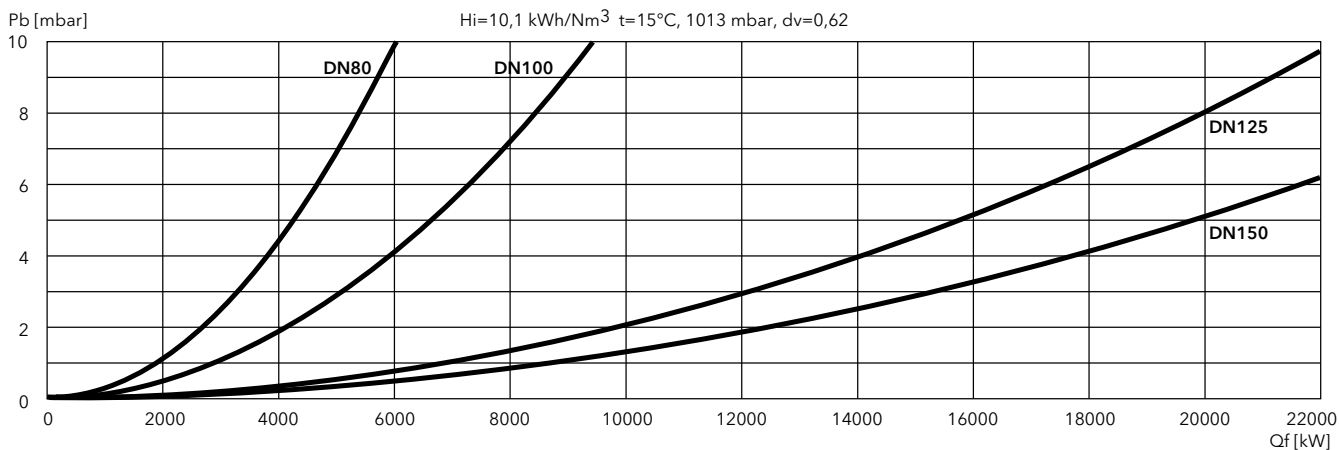

N10 G-EU2

1500 ... 16000 kW

2 stage progressive/modulating electronic (Low NOx class 3)

- **Fuels:** natural gas, Hi = 6,99 ... 11,39 kWh/m³
- **Emission class:** Low NOx class 3 (≤80 mg/kWh) according to EN676
- **Protection level:** IP 40 (IP 54 as option)



TECHNICAL DATA

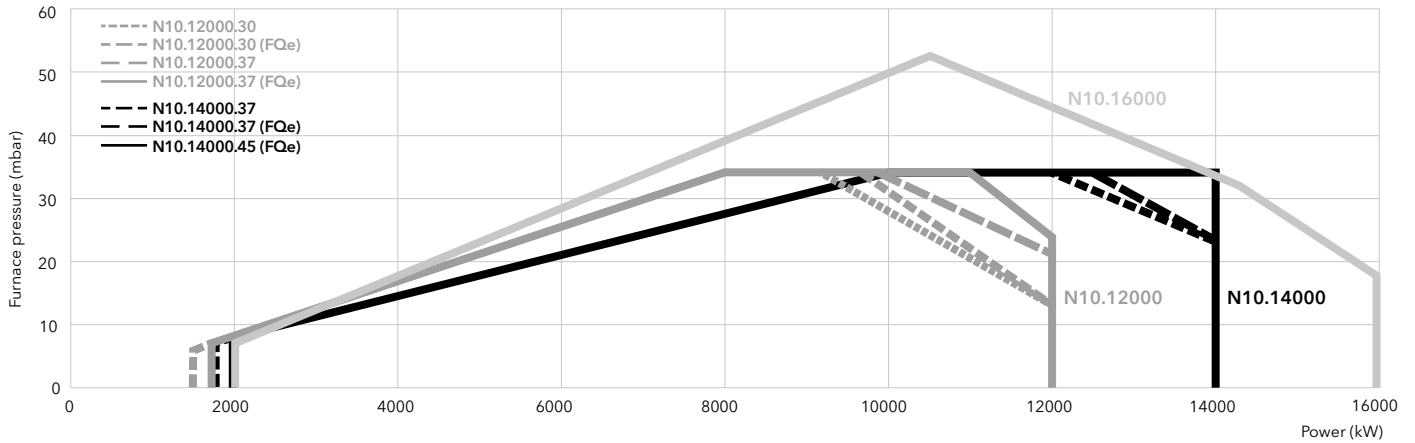

FQe = external frequency converter

	N10.12000.30 G-EU2	N10.12000.37 G-EU2	N10.14000.37 G-EU2	N10.14000.45 G-EU2	N10.16000.45 G-EU2
Operating range	1500* - 12000 kW (*: 1750 without FQ)	1500* - 12000 kW (*: 1750 without FQ)	1750* - 14000 kW (*: 2000 without FQ)	1750 - 14000 kW* (*: with FQe)	2000 - 16000 kW* (*: with FQe)
Gas connection	DN100	DN100	DN100	DN100	DN100
Fan motor	50/60 Hz - 30 kW	50/60 Hz - 37 kW	50/60 Hz - 37 kW	50/60 Hz - 45 kW	50/60 Hz - 45 kW
Acoustic level	< 97 dB(A)	< 97 dB(A)	< 97 dB(A)	< 97 dB(A)	< 97 dB(A)
Complete burner code	on request	on request	on request	on request	on request

GAS TRAINS

DUNGS

Model	Code
d80	on request
d100	on request
d125	on request

SIEMENS

Model	Code
s80	3757394
s100	3757395
s125	3757396
s150	3757397

FILTERS

Model	Code
FG-DN80	3757201
FG-DN100	3757195
FG-DN125	3757209
FG-DN150	3757210

 **Pressure drops graphs:** see following pages
Dimensions of gas trains and gas filters: see pag. 208



DIMENSIONS (mm)

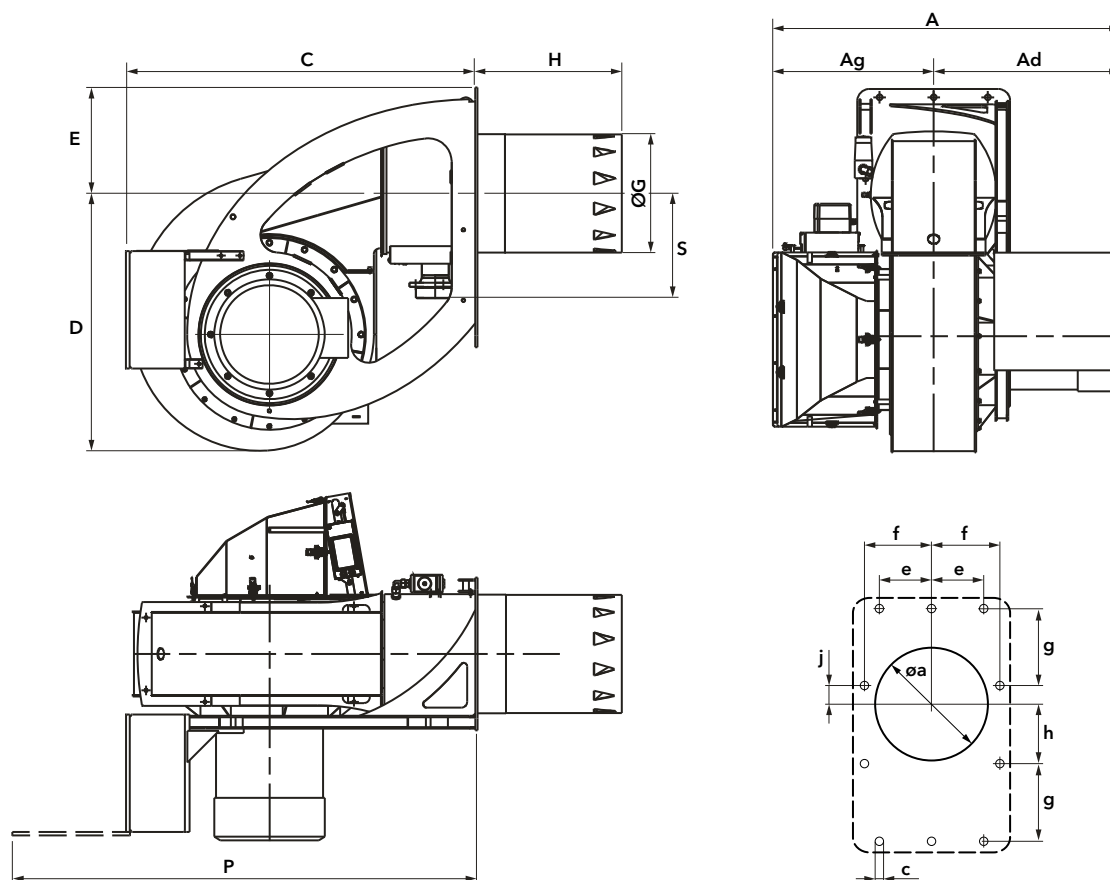

Model	A	Al	Ar	C	D	E	ØG	H			P	S	Øa	c	e	f	g	h	j
								KN	KM	KL									
N10 G-EU2	1480	685	795	1500	1095	450	504	620	720	820	1980	446	525	M20	230	290	345	275	70

PACKAGING

The complete burner is delivered on a pallet with:

- 1 carton box for gas train and filter
- 1 carton box for boiler fixing accessories
- 1 bag with technical documentation

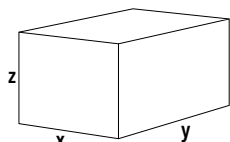

Models	Dimensions (mm)			Gross weight (kg)
	X	Y	Z	
N10 G-EU2	1505	2125	1545	550 (+100 transport rack)

PRESSURE LOSSES (BURNER HEAD + GAS TRAIN)

N10.12000 G-EU2

DUNGS

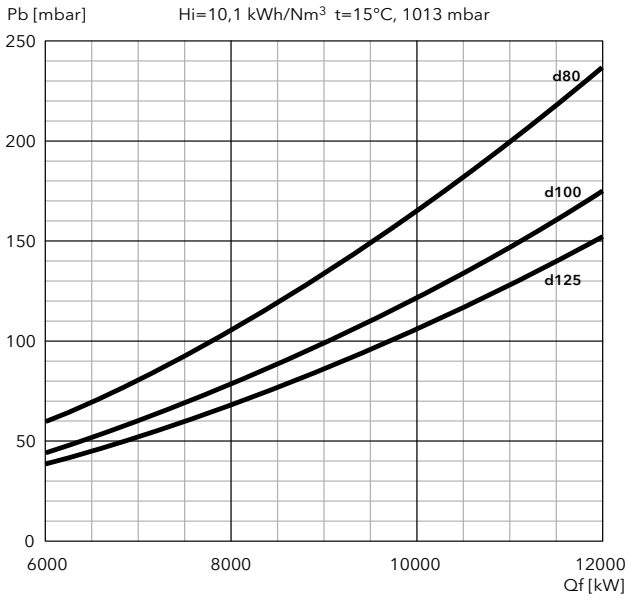

SIEMENS

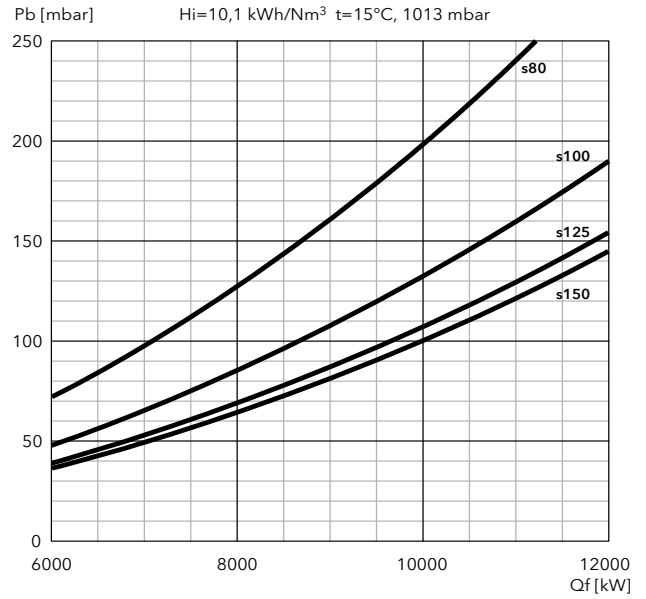

N10.14000 G-EU2

DUNGS

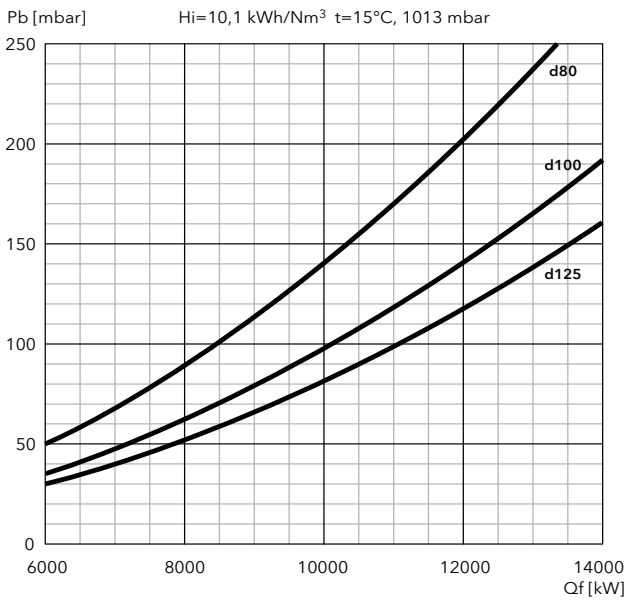

SIEMENS

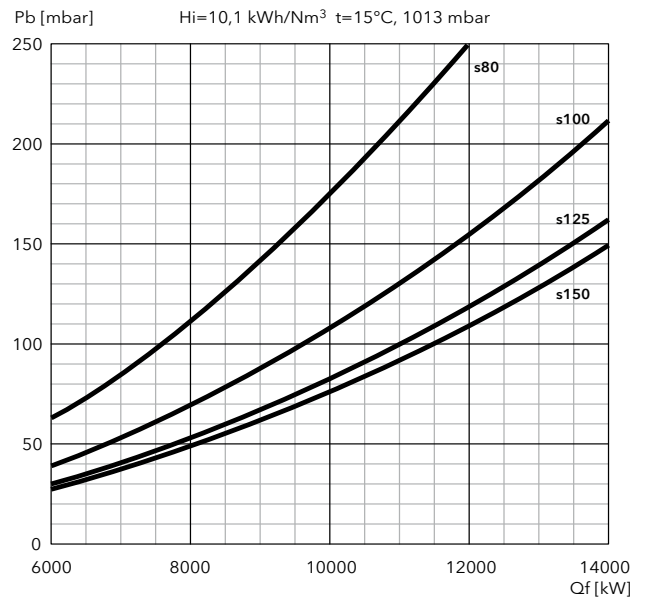

PRESSURE LOSSES (BURNER HEAD + GAS TRAIN)

N10.16000 G-EU2

DUNGS

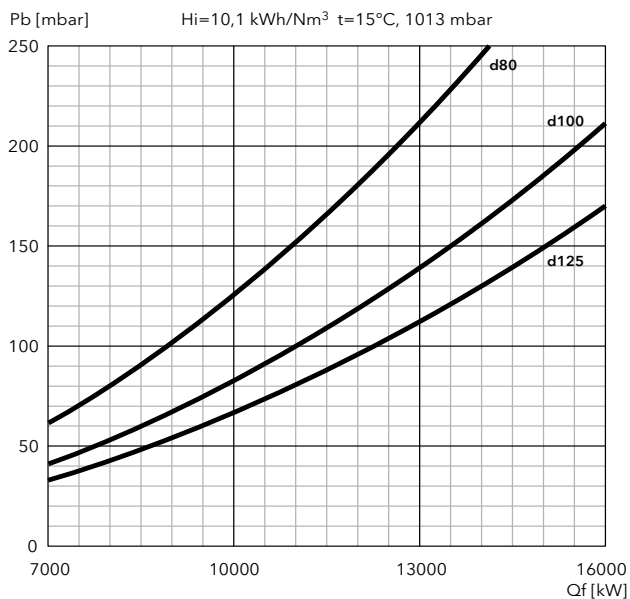

SIEMENS

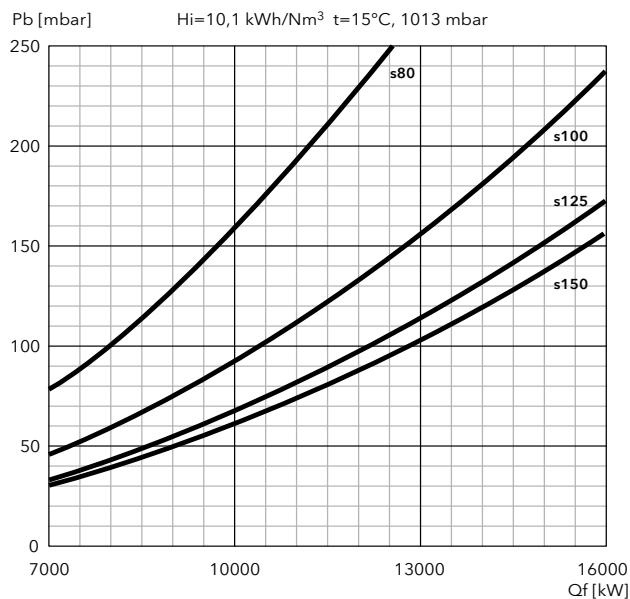

FILTERS

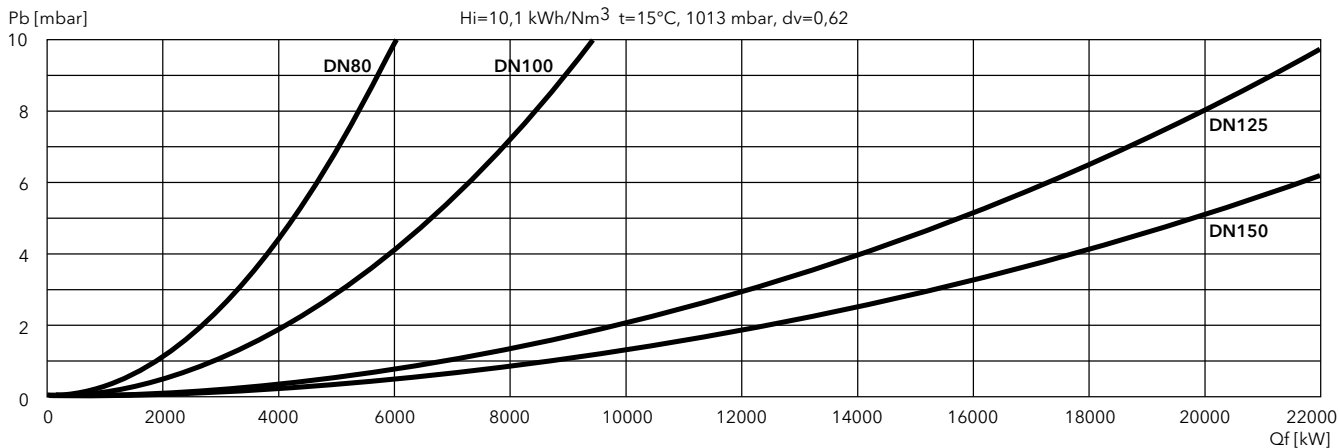

N11 G-EU2

2750 ... 22000 kW

2 stage progressive/modulating electronic (Low NOx class 3)

- **Fuels:** natural gas, Hi = 6,99 ... 11,39 kWh/m³
- **Emission class:** Low NOx class 3 (≤80 mg/kWh) according to EN676
- **Protection level:** IP 41 (optional IP 54)



TECHNICAL DATA

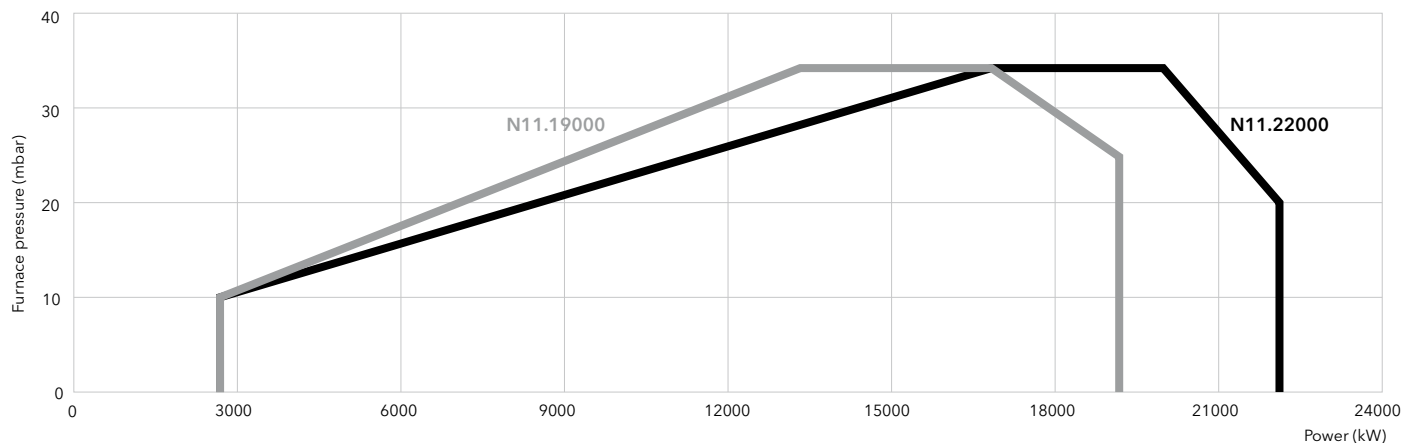

FQe = external frequency converter

	N11.19000.55 G-EU2	N11.22000.75 G-EU2
Operating range	2750 - 19000 kW	2750 - 22000 kW
Gas connection	DN125	DN125
Fan motor	50/60 Hz - 55 kW	50/60 Hz - 75 kW
Acoustic level	< 96,5 dB(A)	< 96,5 dB(A)
Complete burner code	on request	on request

GAS TRAINS

DUNGS

Model	Code
d100	3758179
d125	3758180

SIEMENS

Model	Code
s100	3758176
s125	3758177
s150	3758178

FILTERS

Model	Code
FG-DN100	3757195
FG-DN125	3757209
FG-DN150	3757210

 **Pressure drops graphs:** see following pages
Dimensions of gas trains and gas filters: see pag. 209



DIMENSIONS (mm)

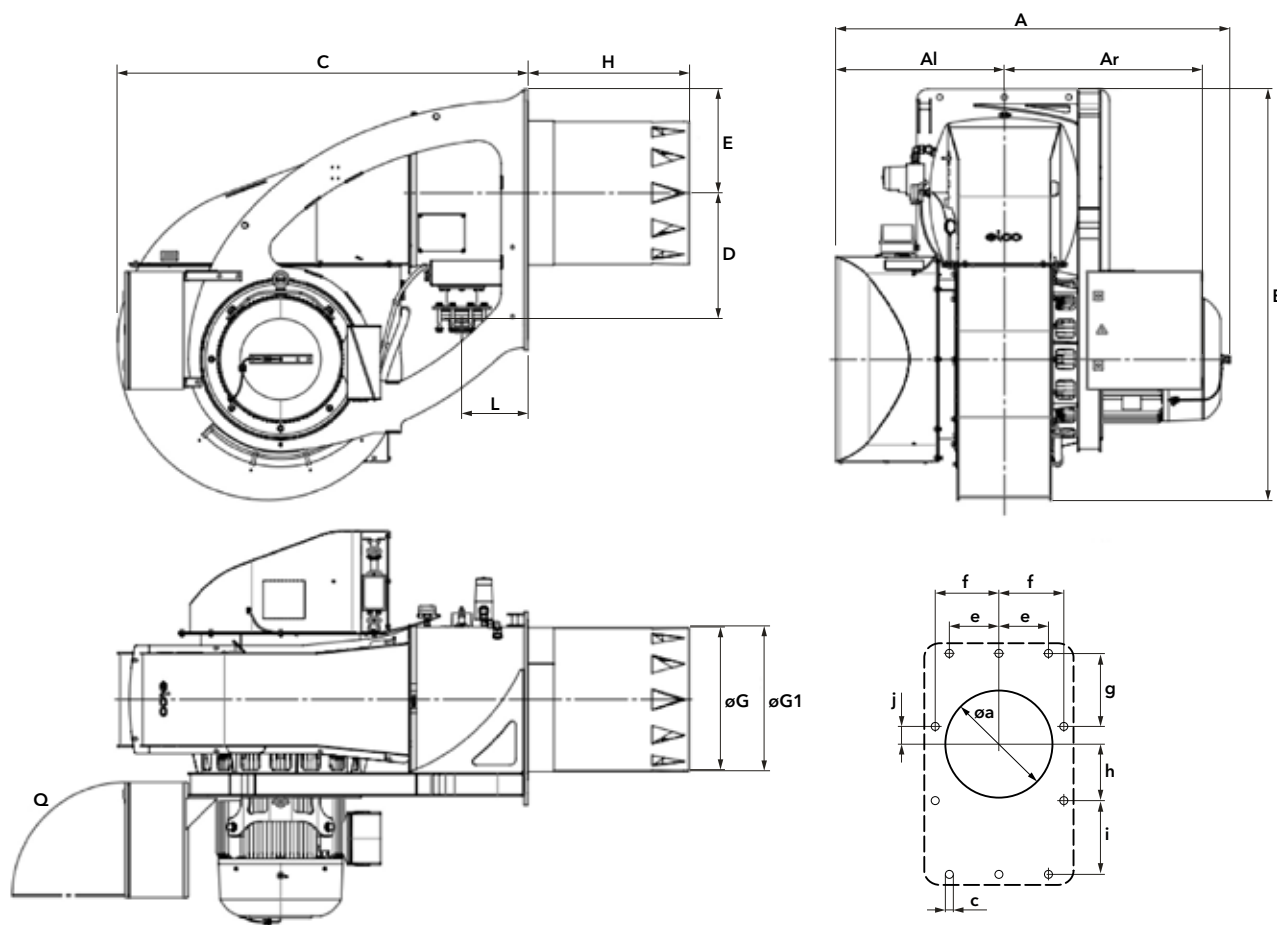

Model	A	Al	Ar	B	C	D	E	ØG	ØG1	H			L	Q	Øa	c	e	f	g	h	i	j
										KN	KM	KL										
N11.19000	1636	730	858	1780	1777	543	450	617	624	700	850	1000	285	800	645	M20	280	345	570	300	345	45
N11.22000	1709	730	858	1780	1777	543	450	617	624	700	850	1000	285	800	645	M20	280	345	570	300	345	45

PACKAGING

The complete burner is delivered on a pallet with:

- 1 carton box for gas train and filter
- 1 carton box for boiler fixing accessories
- 1 bag with technical documentation

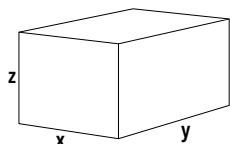

Models	Dimensions (mm)			Gross weight (kg)
	X	Y	Z	
N11 G-EU2	2000	3100	1900	1400...1500

PRESSURE LOSSES (BURNER HEAD + GAS TRAIN)

N11.19000 G-EU2

DUNGS

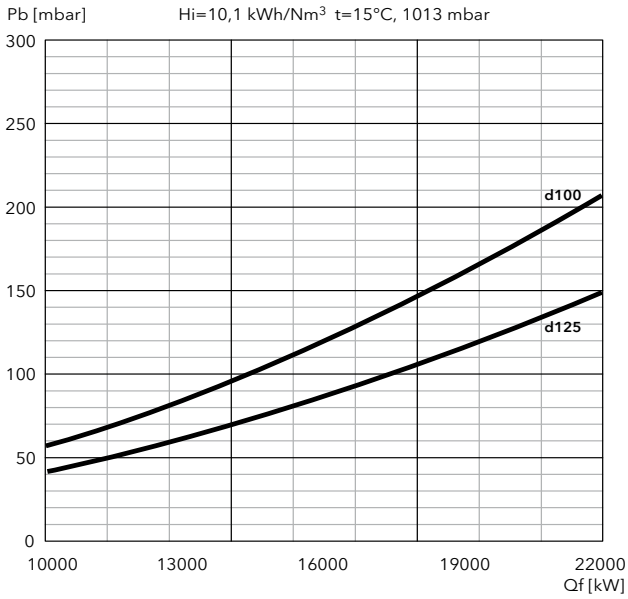

SIEMENS

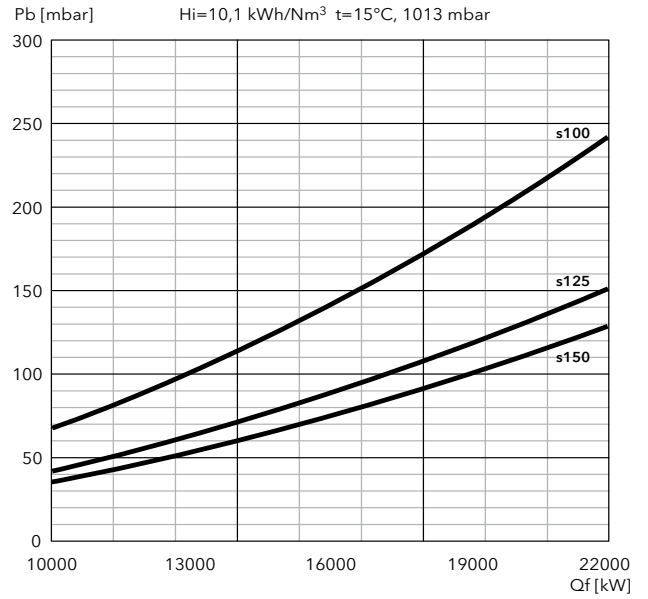

FILTERS

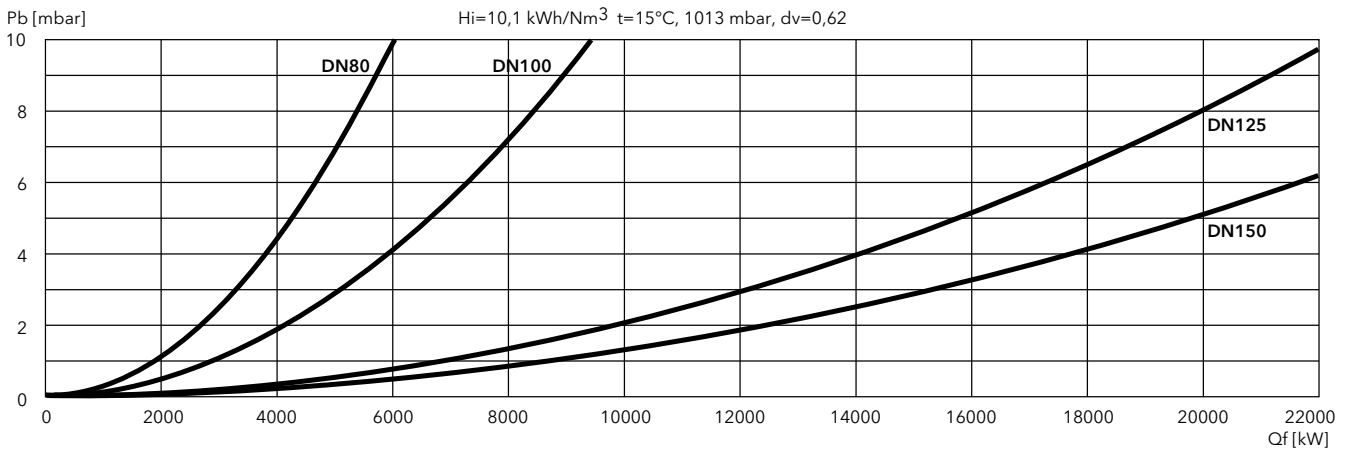

PRESSURE LOSSES (BURNER HEAD + GAS TRAIN)

N11.22000 G-EU2

DUNGS

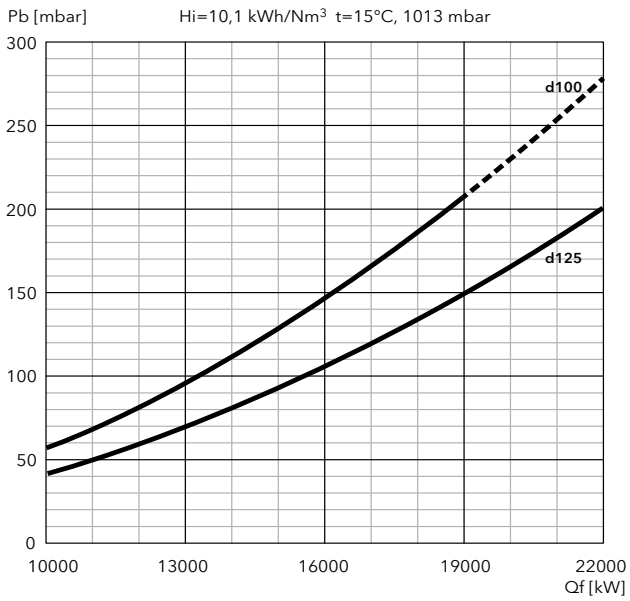

SIEMENS

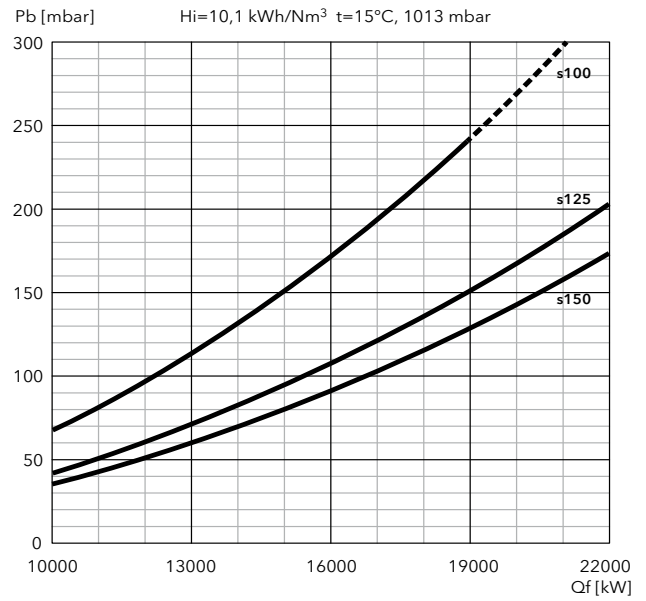

FILTERS

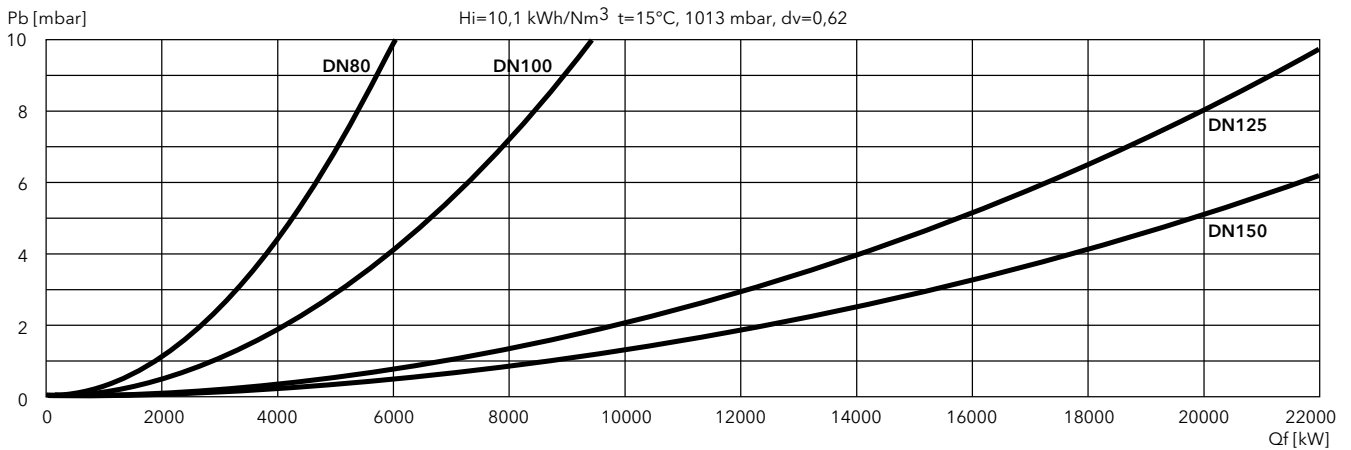

N10 GL-E

1300 ... 12000 kW

2 stage progressive/modulating electronic

- **Fuels:** natural gas, Hi = 6,99 ... 11,39 kWh/Nm³;
light oil, viscosity 6 mm²/s at 20°C, Hi = 11,86 kWh/kg
- **Emission class:** Low NOx class 2 (≤120 mg/kWh) according to EN676 in gas
Low NOx class 2 (≤185 mg/kWh) according to EN267 in light oil
- **Protection level:** IP 41 (IP 54 as option)



TECHNICAL DATA

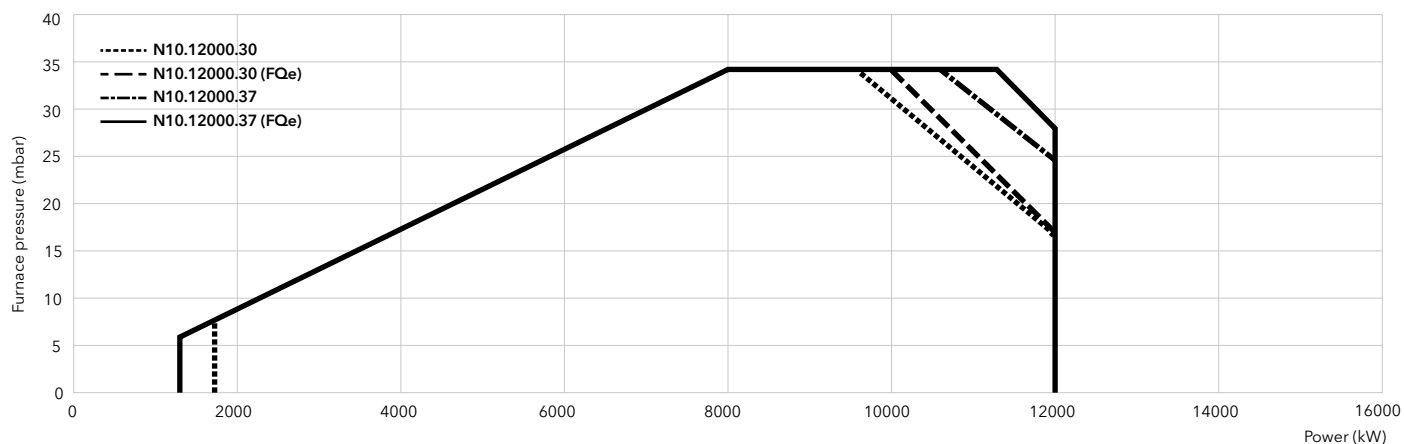

FQe = external frequency converter

	N10.12000.30 GL-E	N10.12000.37 GL-E
Operating range gas	1300* - 12000 kW (*: 1750 without FQ)	1300* - 12000 kW (*: 1750 without FQ)
Operating range oil	3600 - 12000 kW	3600 - 12000 kW
Gas connection	DN100	DN100
Fan motor	50/60 Hz - 30 kW	50/60 Hz - 37 kW
Pump	2700 l/h - 4 kW	2700 l/h - 4 kW
Acoustic level	< 97 dB(A)	< 97 dB(A)
Complete burner code	on request	on request

GAS TRAINS

DUNGS

Model	Code
d80	on request
d100	on request
d125	on request

SIEMENS

Model	Code
s80	3757394
s100	3757395
s125	3757396
s150	3757397

FILTERS

Model	Code
FG-DN80	3757201
FG-DN100	3757195
FG-DN125	3757209
FG-DN150	3757210

 **Pressure drops graphs:** see following pages
Dimensions of gas trains and gas filters: see pag. 208



DIMENSIONS (mm)

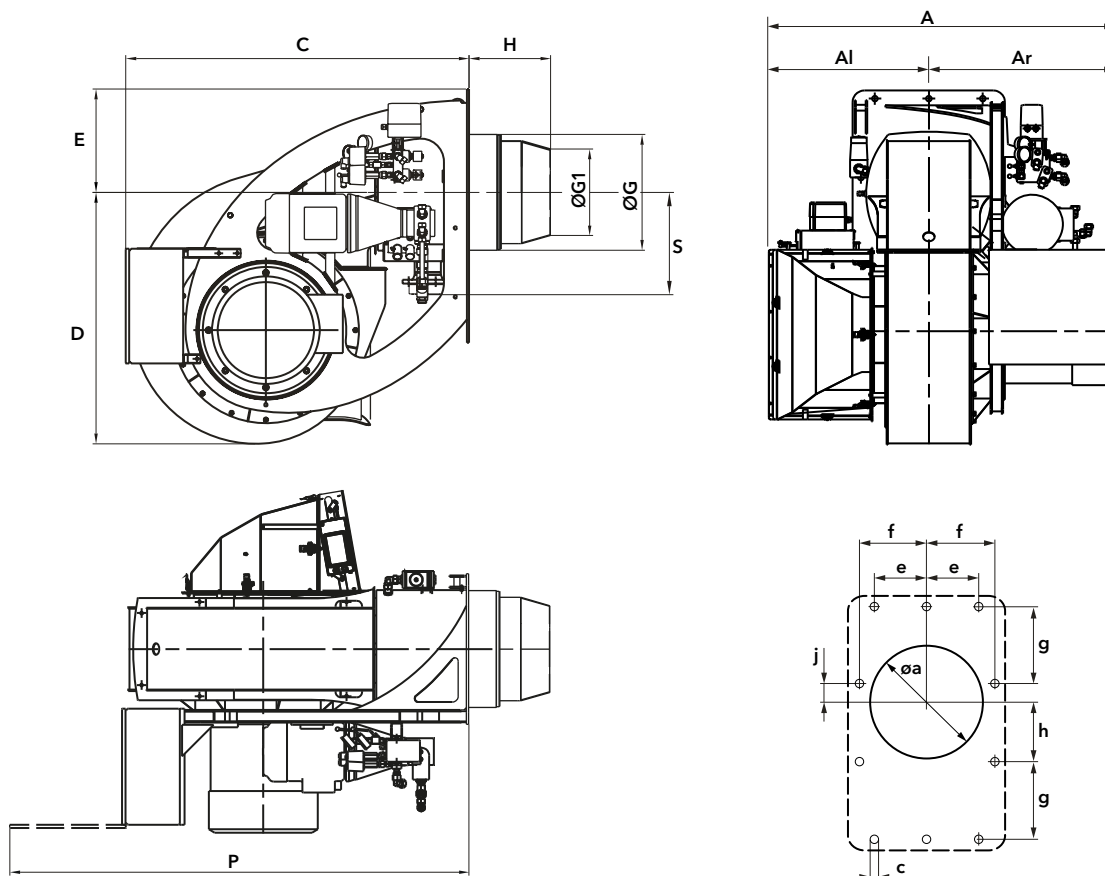

Model	A	Al	Ar	C	D	E	ØG	ØG1	H			P	S	Øa	c	e	f	g	h	j
									KN	KM	KL									
N10 GL-E	1480	685	795	1500	1095	450	504	369	350	450	550	1980	446	525	M20	230	290	345	275	70

PACKAGING

The complete burner is delivered on a pallet with:

- 1 carton box for gas train and filter
- 1 carton box for flexible hoses
- 1 carton box for boiler fixing accessories
- 1 bag with technical documentation

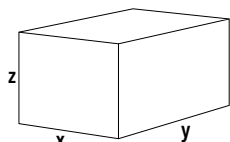

Models	Dimensions (mm)			Gross weight (kg)
	X	Y	Z	
N10 GL-E	1505	2125	1545	650 (+100 transport rack)

N10 GL-EUF

1500 ... 12000 kW

2 stage progressive/modulating electronic (Low NOx class 3)

- **Fuels:** natural gas, Hi = 6,99 ... 11,39 kWh/Nm³;
light oil, viscosity 6 mm²/s at 20°C, Hi = 11,86 kWh/kg
- **Emission class:** Low NOx class 3 (≤80 mg/kWh) according to EN676 in gas
Low NOx class 3 (≤120 mg/kWh) according to EN267 in light oil
- **Protection level:** IP 41 (IP 54 as option)



TECHNICAL DATA

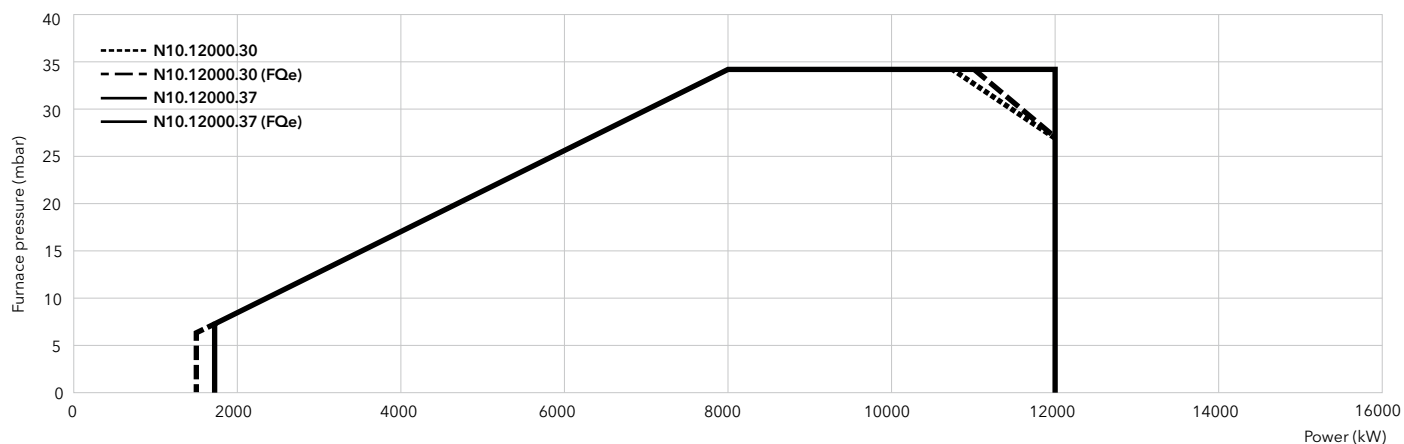

FQe = external frequency converter

	N10.12000.30 GL-EUF	N10.12000.37 GL-EUF
Operating range gas	1500* - 12000 kW (*: 1750 without FQ)	1500* - 12000 kW (*: 1750 without FQ)
Operating range oil	3000 - 12000 kW	3000 - 12000 kW
Gas connection	DN100	DN100
Fan motor	50/60 Hz - 30 kW	50/60 Hz - 37 kW
Pump	2200 l/h - 4 kW	2200 l/h - 4 kW
Acoustic level	< 97 dB(A)	< 97 dB(A)
Complete burner code	on request	on request

GAS TRAINS

DUNGS

Model	Code
d80	on request
d100	on request
d125	on request

SIEMENS

Model	Code
s80	3757394
s100	3757395
s125	3757396
s150	3757397

FILTERS

Model	Code
FG-DN80	3757201
FG-DN100	3757195
FG-DN125	3757209
FG-DN150	3757210

 **Pressure drops graphs:** see following pages
Dimensions of gas trains and gas filters: see pag. 208



DIMENSIONS (mm)

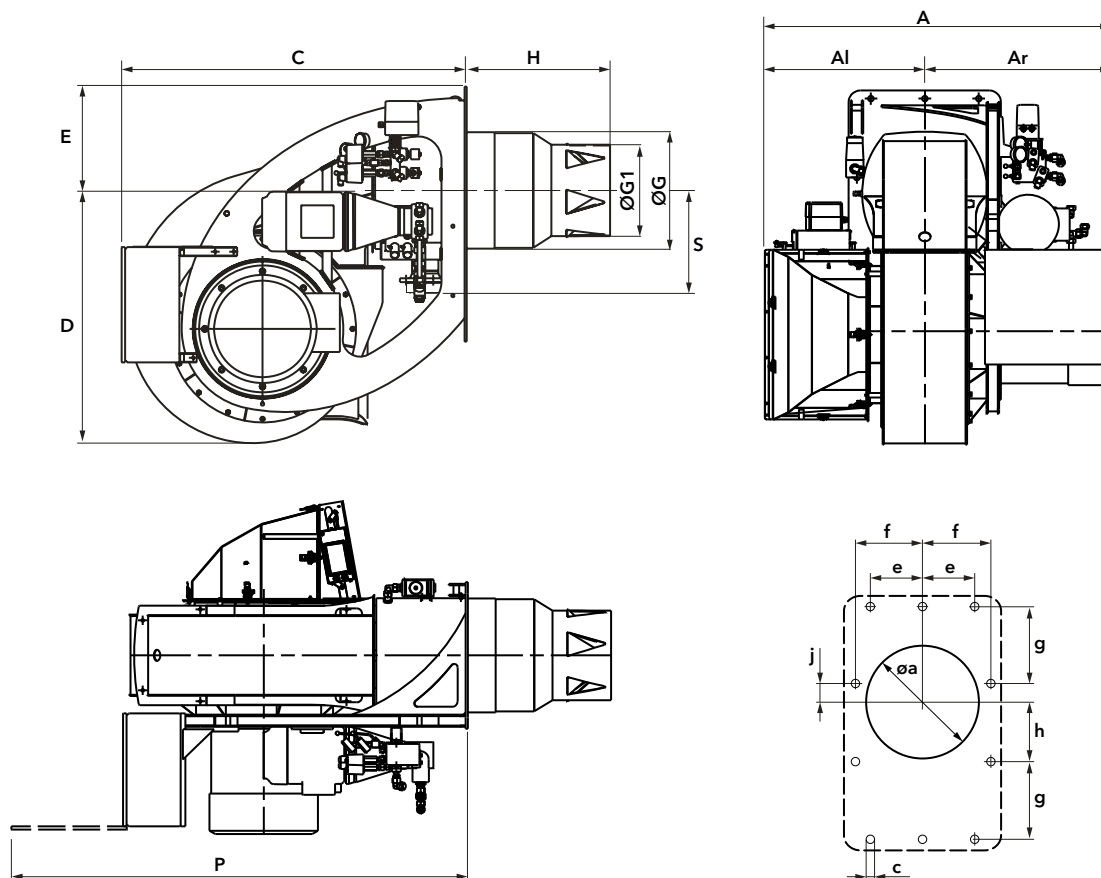

Model	A	Al	Ar	C	D	E	ØG	ØG1	H			P	S	Øa	c	e	f	g	h	j
									KN	KM	KL									
N10 GL-EUF	1480	685	795	1500	1095	450	504	390	620	720	820	1980	446	525	M20	230	290	345	275	70

PACKAGING

The complete burner is delivered on a pallet with:

- 1 carton box for gas train and filter
- 1 carton box for flexible hoses
- 1 carton box for boiler fixing accessories
- 1 bag with technical documentation

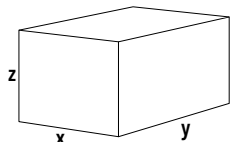

Models	Dimensions (mm)			Gross weight (kg)
	X	Y	Z	
N10 GL-EUF	1505	2125	1545	650 (+100 transport rack)

PRESSURE LOSSES (BURNER HEAD + GAS TRAIN)

N10.12000 GL-E

DUNGS

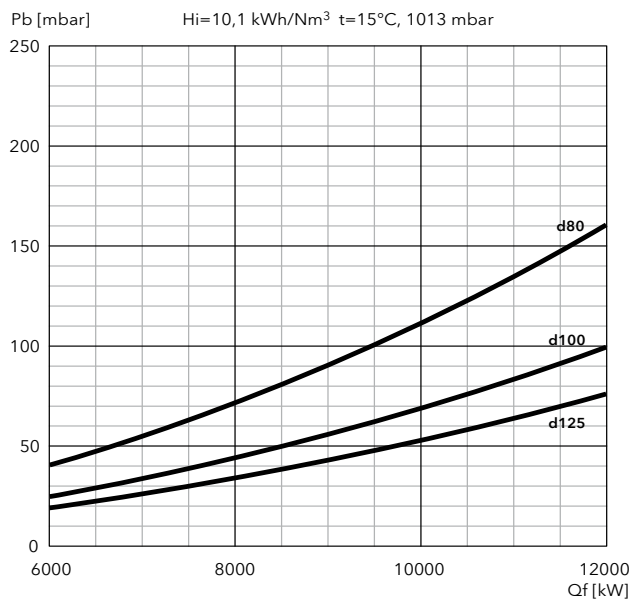

SIEMENS

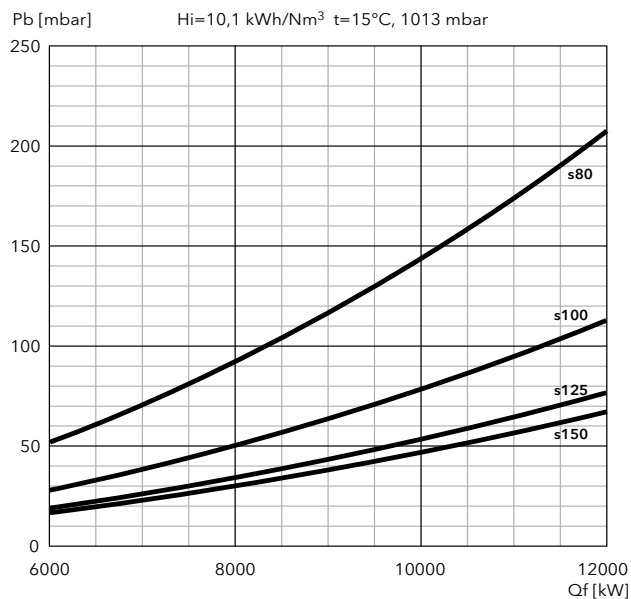

FILTERS

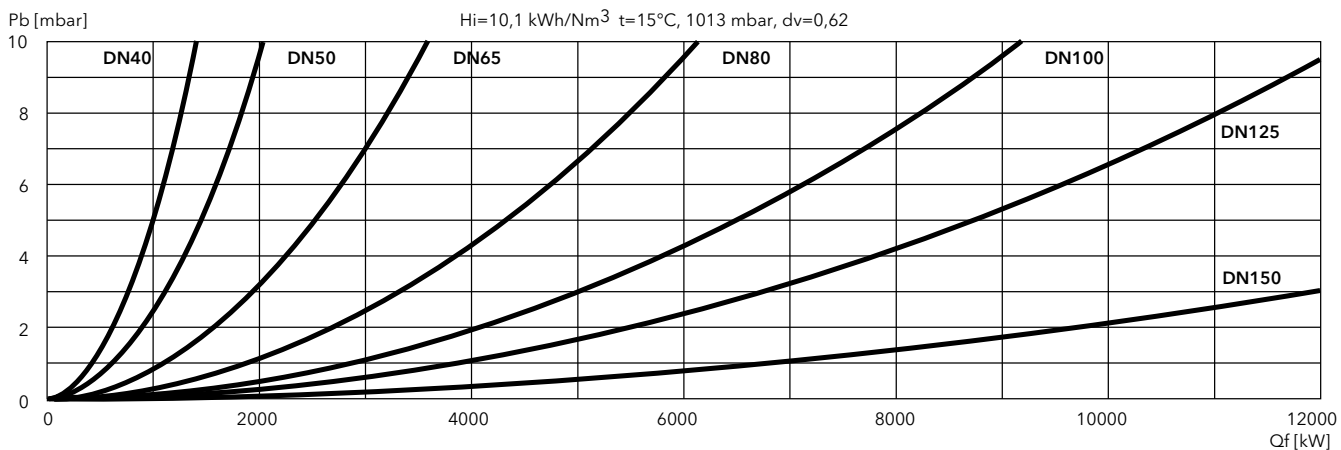

PRESSURE LOSSES (BURNER HEAD + GAS TRAIN)

N10.12000 GL-EUF

DUNGS

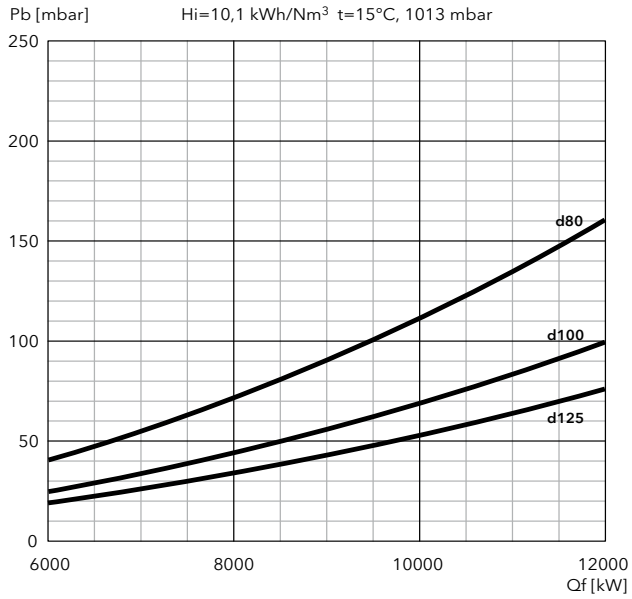

SIEMENS

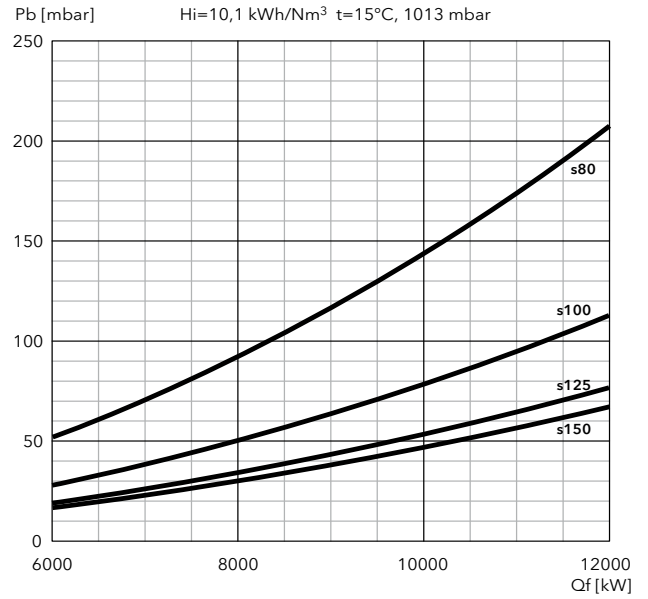

FILTERS

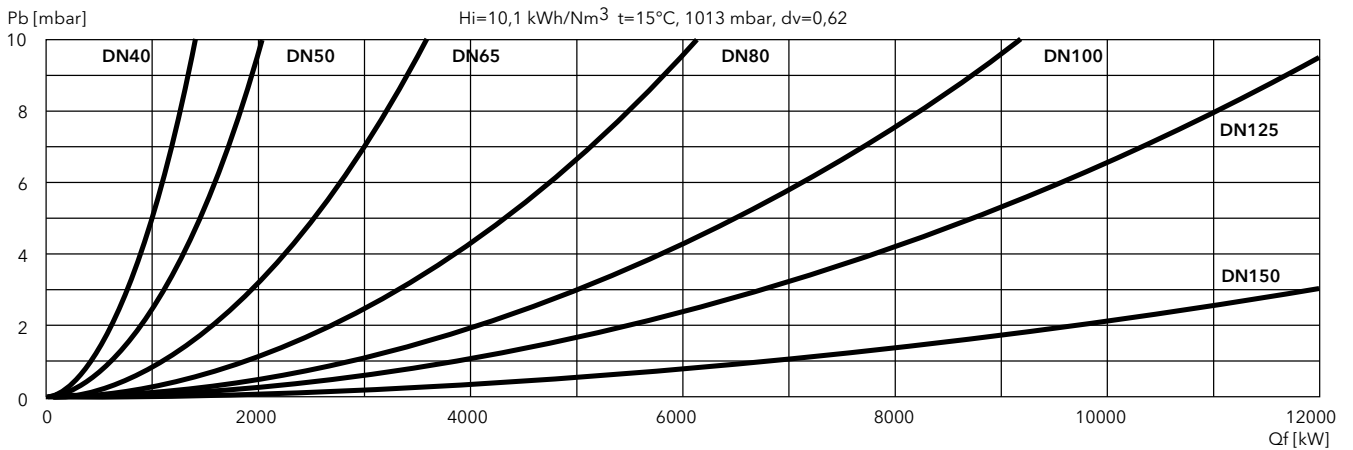

N10 L-E

3600 ... 12000 kW

2 stage progressive/modulating electronic

- **Fuels:** light oil, viscosity 6 mm²/s at 20°C, Hi = 11,86 kWh/kg
- **Emission class:** Low NOx class 2 (≤185 mg/kWh) according to EN267 in light oil
- **Protection level:** IP 41 (IP 54 as option)



TECHNICAL DATA

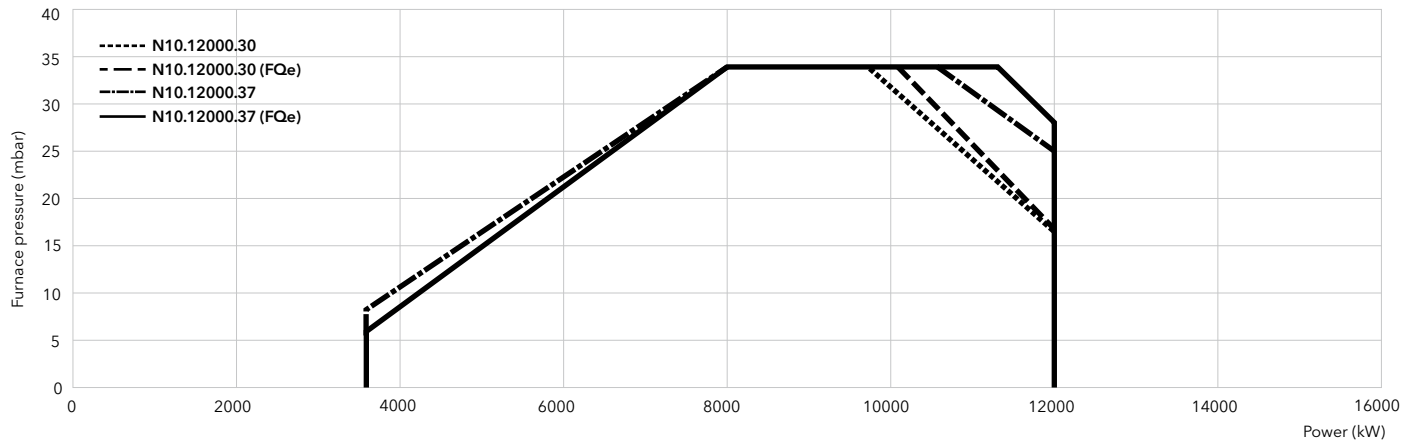

FQe = external frequency converter

	N10.12000.30 L-E	N10.12000.37 L-E
Operating range	3600 - 12000 kW	3600 - 12000 kW
Fan motor	50/60 Hz - 30 kW	50/60 Hz - 37 kW
Pump	2 200 l/h - 4 kW	2 200 l/h - 4 kW
Acoustic level	< 97 dB(A)	< 97 dB(A)
Complete burner code	on request	on request



DIMENSIONS (mm)

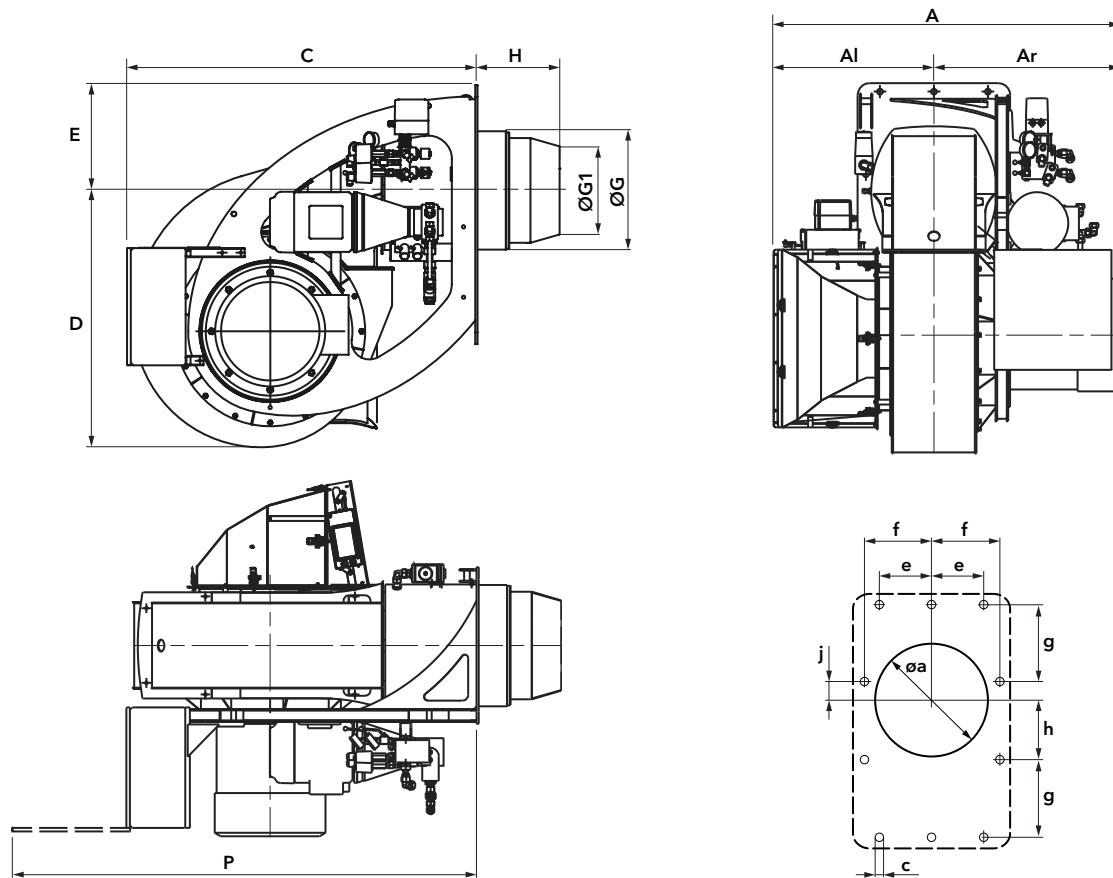

Model	A	Al	Ar	C	D	E	ØG	ØG1	H			P	Øa	c	e	f	g	h	j
									KN	KM	KL								
N10 L-E	1480	685	795	1500	1095	450	504	369	350	450	550	1980	525	M20	230	290	345	275	70

PACKAGING

The complete burner is delivered on a pallet with:

- 1 carton box for boiler fixing accessories
- 1 bag with technical documentation

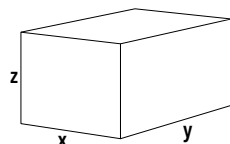

Models	Dimensions (mm)			Gross weight (kg)
	X	Y	Z	
N10 L-E	1505	2125	1545	650 (+100 transport rack)

N10 L-EUF

3000 ... 16000 kW

2 stage progressive/modulating electronic (Low NOx class 3)

- **Fuels:** light oil, viscosity 6 mm²/s at 20°C, Hi = 11,86 kWh/kg
- **Emission class:** Low NOx class 3 (≤120 mg/kWh) according to EN267
- **Protection level:** IP 40 (IP 54 as option)



TECHNICAL DATA

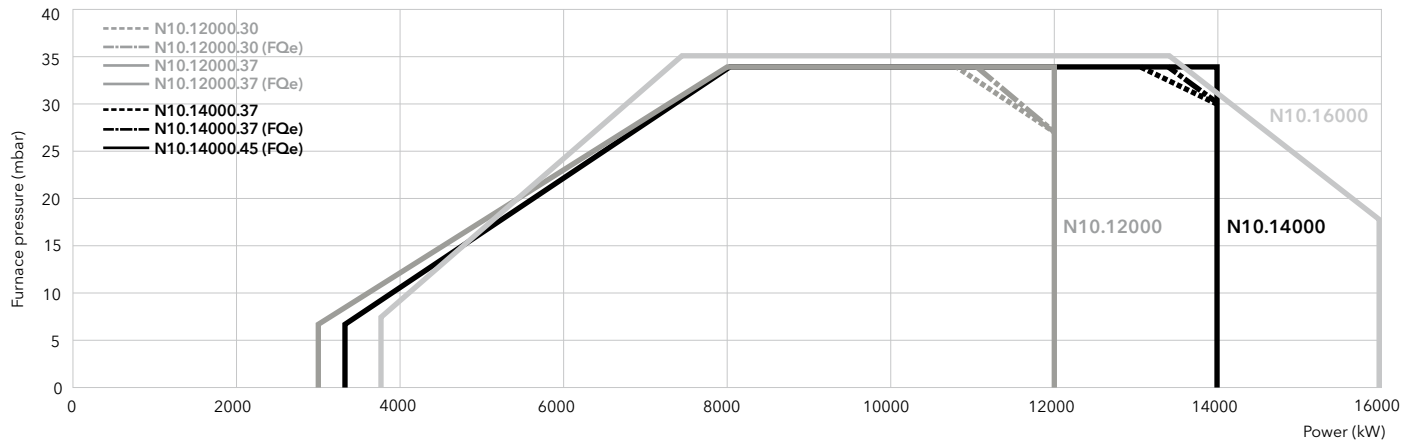

FQe = external frequency converter

	N10.12000.30 L-EUF	N10.12000.37 L-EUF	N10.14000.37 L-EUF	N10.14000.45 L-EUF	N10.16000.45 L-EUF
Operating range	3000 - 12000 kW	3000 - 12000 kW	3300 - 14000 kW	3300 - 14000 kW	3800 - 16000 kW
Fan motor	50/60 Hz - 30 kW	50/60 Hz - 37 kW	50/60 Hz - 37 kW	50/60 Hz - 45 kW	50/60 Hz - 45 kW
Pump	2700 l/h - 4 kW	2700 l/h - 4 kW	2700 l/h - 4 kW	2700 l/h - 4 kW	2700 l/h - 4 kW
Acoustic level	< 97 dB(A)	< 97 dB(A)	< 97 dB(A)	< 97 dB(A)	< 97 dB(A)
Complete burner code	on request	on request	on request	on request	on request



DIMENSIONS (mm)

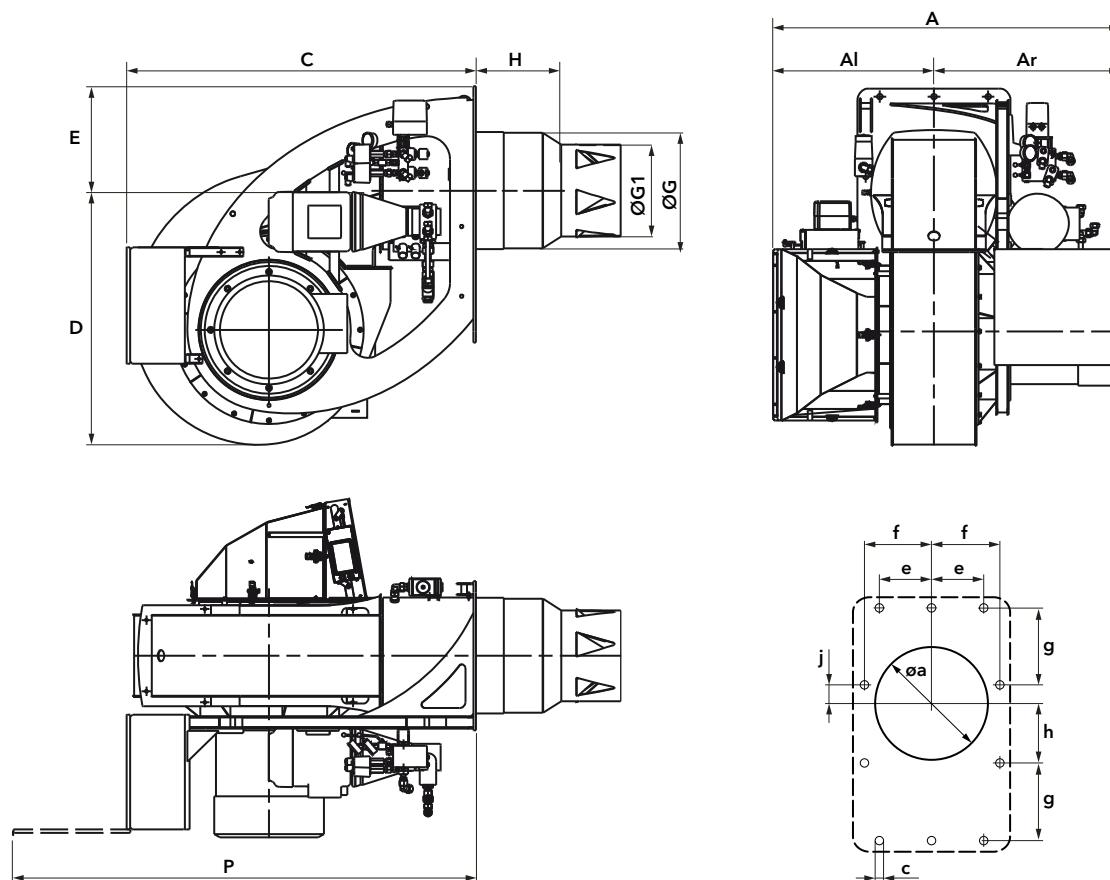

Model	A	AI	Ar	C	D	E	ØG	ØG1	H			P	Øa	c	e	f	g	h	j
									KN	KM	KL								
N10 L-EUF	1480	685	795	1500	1095	450	504	390	620	720	820	1980	525	M20	230	290	345	275	70

PACKAGING

The complete burner is delivered on a pallet with:

- 1 carton box for boiler fixing accessories
- 1 bag with technical documentation

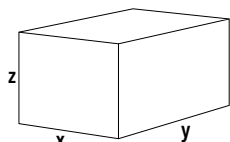

Models	Dimensions (mm)			Gross weight (kg)
	X	Y	Z	
N10 L-EUF	1505	2125	1545	650 (+100 transport rack)

Monoblock burners from 68 to 17000 kW

Heavy oil

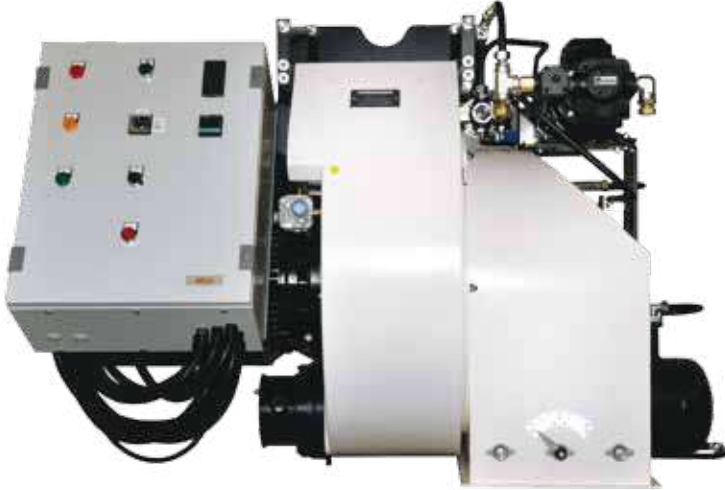

ELCO offers a wide range of heavy oil burners designed for traditional applications and industrial process applications. All models are suitable to work with heavy oil up to 50°E at 50°C.

HO-TRON range is available in different configurations with a power output covering a range from 68 kW to 17 MW.

Burners are available in the following versions:

- one stage, for HO-TRON 0 and HO-TRON 1, models up to 340 kW;
- two stages, up to the model HO-TRON 4;
- two stage progressive mechanical operation (up to 17 MW).

All burners feature easy access to the combustion component in order to simplify the maintenance operations. The maintenance activities are simplified also thanks to the slide bar system, which allows easy access to the combustion components, available on all models up to HO-TRON 6.

All models are fitted with heavy oil electric heating system on board and integrated electrical panel complete with pre-heater management system.

Ring system components for oil preparation can be designed and supply on request.

For a large extent of applications customized solutions can be offered in order to meet plants requirements.



MAIN TECHNICAL FEATURES

- One stage, two stages and two stage progressive/modulating mechanical forced draught burners
- Electronic version available on request
- Fuel: heavy oil, viscosity 50°E at 50°C, Hi = 10,97 kWh/kg
- Two combustion head lengths available
- Pump mounted on the body up to model HO-TRON 6.8500 and separated motor-pump starting from model HO-TRON 6.10500
- Electrical heavy oil heater on board (oil supply to the burner at 80°C and 3 bar)
- Additional heaters on the pipes and the valves, into the pump and the nozzle holder
- Closing of the air flap on burner shut-down
- Complete control panel mounted on the burner with electrical equipment
- Products are in compliance with EN267 European standards and with the following directives:
 - 2014/35/UE Low Voltage Directive
 - 2014/30/UE EMC Directive
 - 2006/42/EC Machinery Directive
 - 2011/65/EU RoHS2 Directive

RANGE OVERVIEW

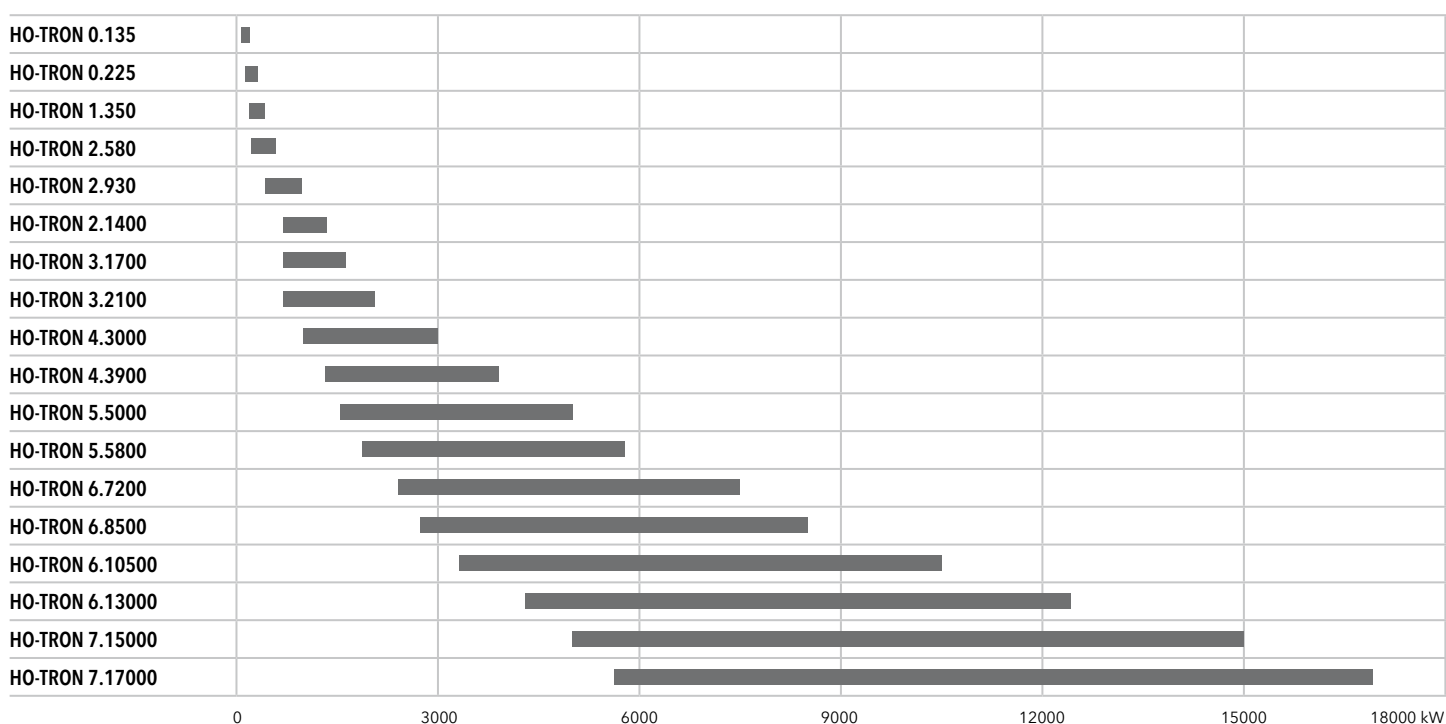

HO-TRON 0

68 ... 227 kW
1 stage

- **Fuel:** heavy oil, viscosity 50°E at 50°C, Hi = 10,5...11,5 kWh/kg
- **Protection level:** IP 42 (IP54 on request)



TECHNICAL DATA

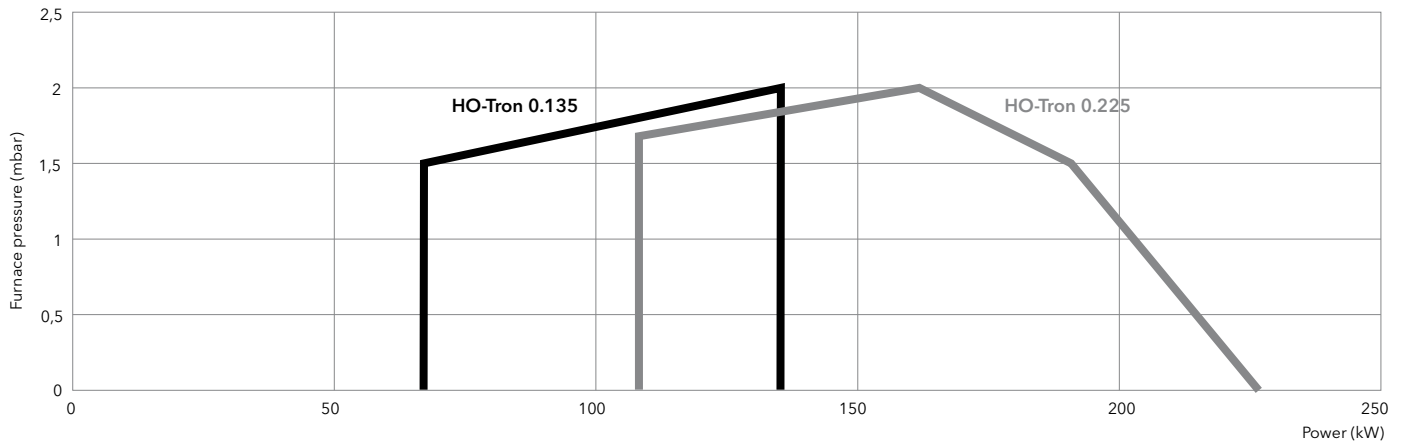

	HO-TRON 0.135		HO-TRON 0.225	
Operating range	68 - 136 kW		108 - 227 kW	
Fuel flow	6 - 12 kg/h		9,5 - 20 kg/h	
Nozzles	according to required power		according to required power	
Control box	LMO 44		LMO 44	
Fan motor	2 800 rpm - 230 V - 50 Hz - 450 W		2 800 rpm - 230 V - 50 Hz - 450 W	
Pump	D67C		D67C	
Resistance on pre-heaters	2 x 650 W		3 x 650 W	
Head lenght	KN	KL	KN	KL
Complete burner code	3142568	3142569	3142570	3142571



DIMENSIONS (mm)

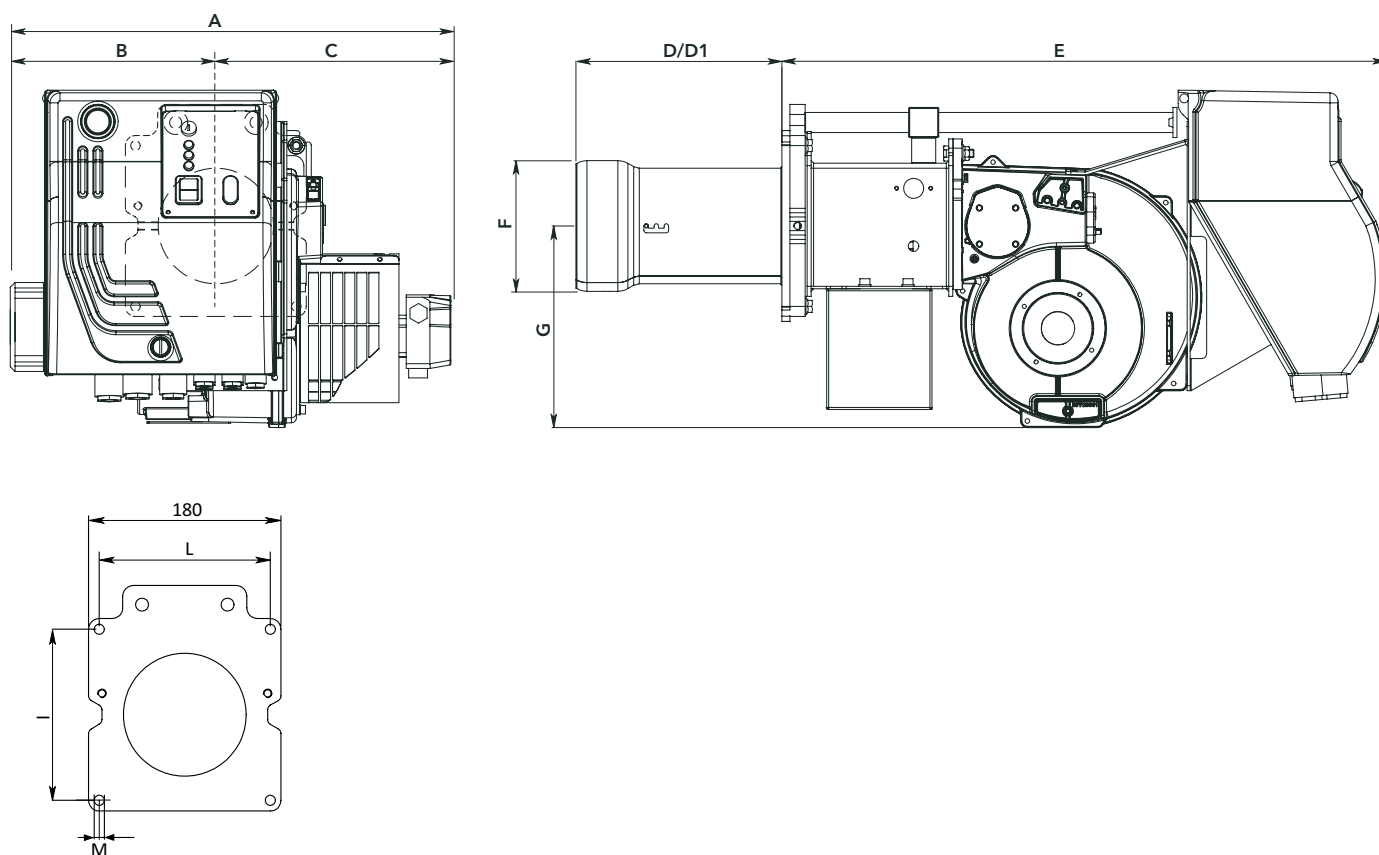

Model	A	B	C	D	D1	E	F	G	I	L	M
HO-TRON 0	520	290	230	205	325	535	130	201	160	160	M8

PACKAGING

The complete burner with combustion head is delivered in a single carton box with flexible hoses and operating manual including electrical terminal diagram and spare parts list.

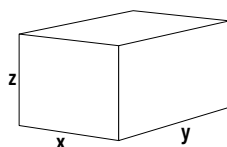

Models	Dimensions (mm)		
	X	Y	Z
HO-TRON 0	900	780	700

HO-TRON 1, HO-TRON 1 Z, HO-TRON 2 Z

170 ... 570 kW
1 and 2 stages

- **Fuel:** heavy oil, viscosity 50°E at 50°C, Hi = 10,5...11,5 kWh/kg
- **Protection level:** IP 40



TECHNICAL DATA

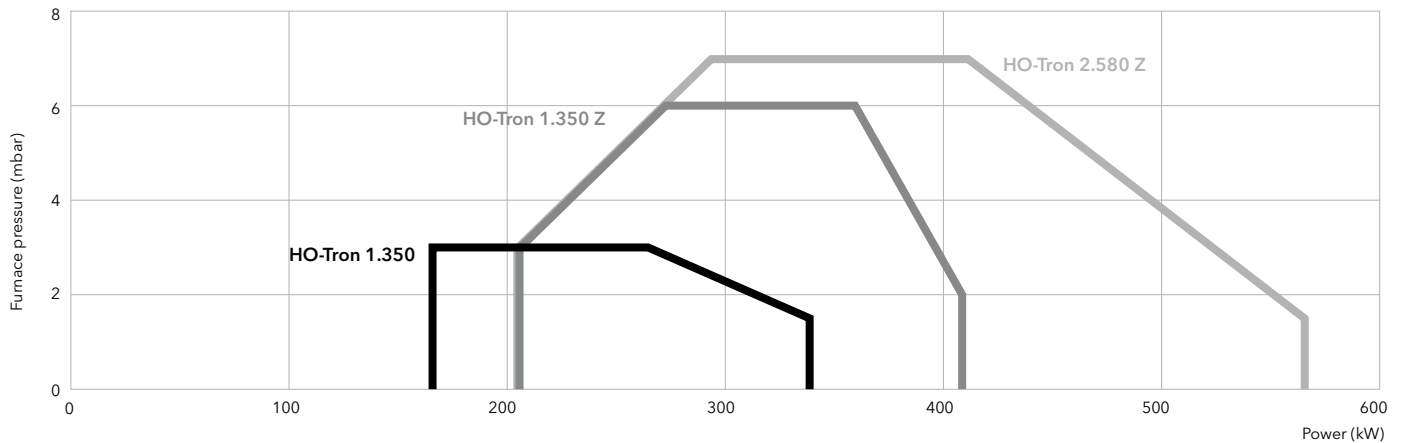

	HO-TRON 1.350		HO-TRON 1.350 Z		HO-TRON 2.580 Z	
Operating range	170 - 340 kW		205 - 410 kW		205 - 570 kW	
Fuel flow	15 - 30 kg/h		18 - 36 kg/h		18 - 50 kg/h	
Nozzles	according to required power		according to required power		according to required power	
Control box	LMO 44		LMO 44		LMO 44	
Fan motor	2 800 rpm - 230/400 V - 50 Hz - 740 W		2 800 rpm - 230/400 V - 50 Hz - 740 W		2 800 rpm - 230/400 V - 50 Hz - 1100 W	
Pump	E4 NC 1069		E4 NC 1069		E4 NC 1069	
Resistance on pre-heaters	3,9 kW		3,9 kW		3,9 kW	
Head lenght	KN	KL	KN	KL	KN	KL
Complete burner code	on request	on request	on request	on request	3142671	on request



DIMENSIONS (mm)

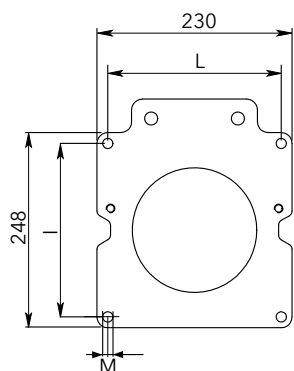
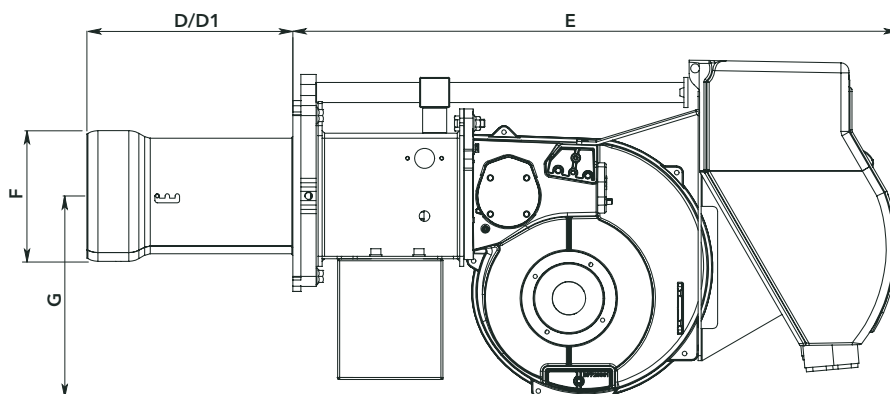
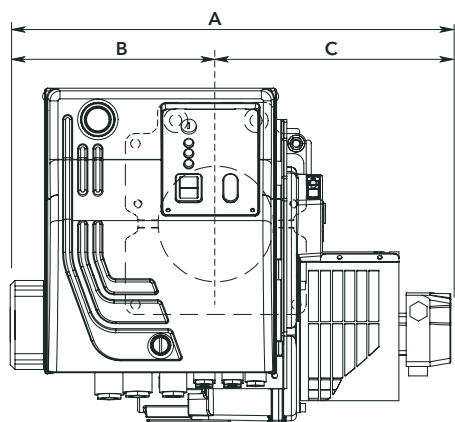

Model	A	B	C	D	D1	E	F	G	I	L	M
HO-TRON 1-2	562	302	260	205	325	653	160	280	185/200	185/200	M10

PACKAGING

The complete burner with combustion head is delivered in a single carton box with flexible hoses and operating manual including electrical terminal diagram and spare parts list.

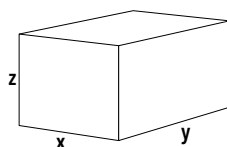

Models	Dimensions (mm)		
	X	Y	Z
HO-TRON 1-2	900	780	700

HO-TRON 2 Z

465 ... 1395 kW
2 stages

- **Fuel:** heavy oil, viscosity 50°E at 50°C, Hi = 10,5...11,5 kWh/kg
- **Protection level:** IP 42 (IP54 on request)



TECHNICAL DATA

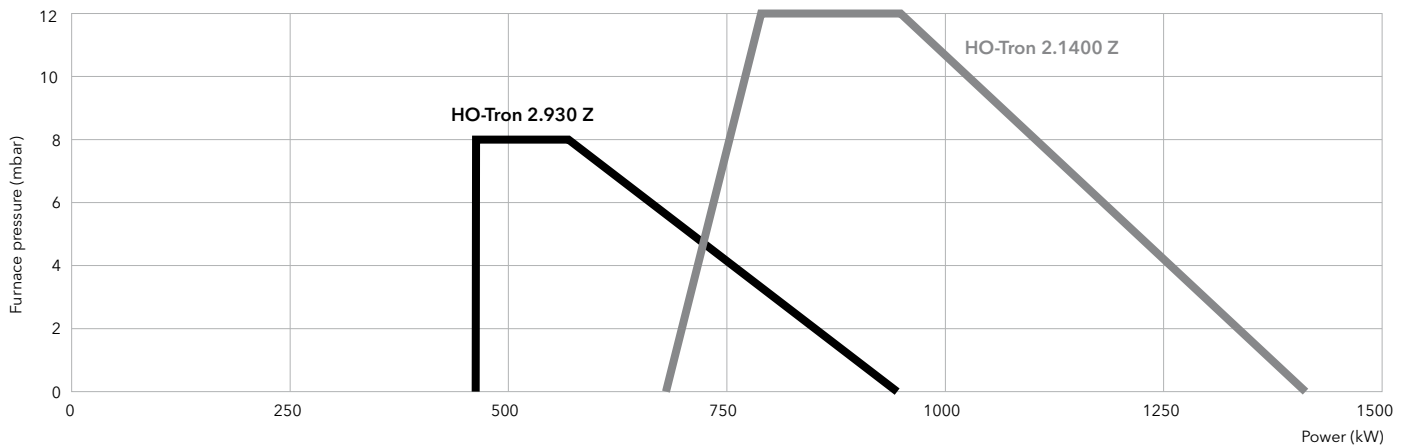

	HO-TRON 2.930 Z		HO-TRON 2.1400 Z	
Operating range	465 - 930 kW		682 - 1395 kW	
Fuel flow	41 - 82 kg/h		60 - 122 kg/h	
Nozzles	according to required power		according to required power	
Control box	LMO 44		LMO 44	
Fan motor	2800 rpm - 230 V - 50 Hz - 1,5 kW		2800 rpm - 230 V - 50 Hz - 2,2 kW	
Pump	E4 NC 1069		E4 NC 1069	
Resistance on pre-heaters	4,65 kW		7,05 kW	
Head lenght	KN	KL	KN	KL
Complete burner code	3142672	3142215	3142673	3143193



DIMENSIONS (mm)

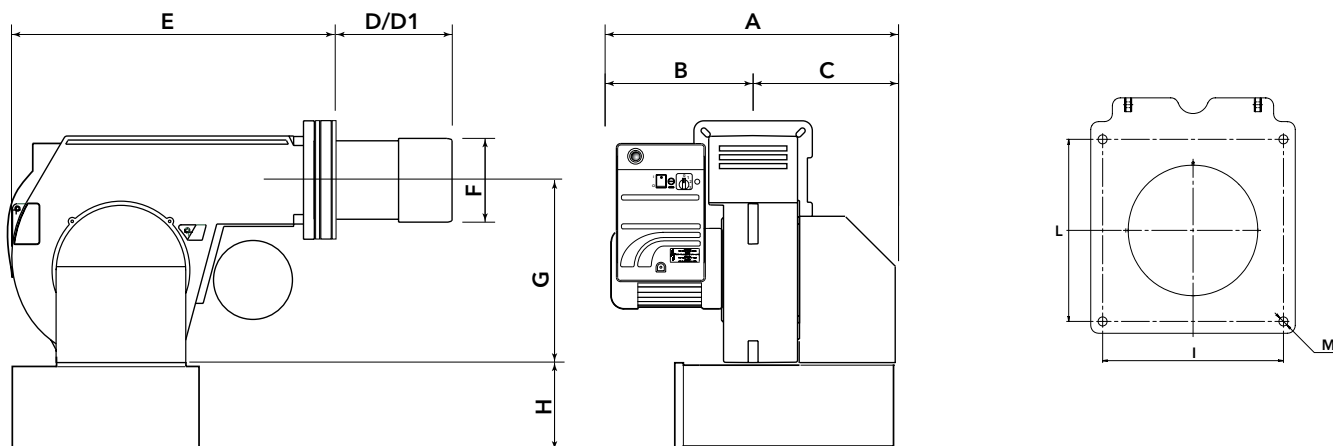

Model	A	B	C	D	D1	E	F	G	H	I	L	M
HO-TRON 2	758	388	370	170	310	600	185	390	210*	190	190	M10

PACKAGING

The complete burner with combustion head is delivered in a single carton box with flexible hoses and operating manual including electrical terminal diagram and spare parts list.

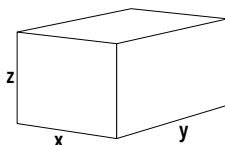

Models	Dimensions (mm)		
	X	Y	Z
HO-TRON 2	1100	780	700

HO-TRON 3 Z

682 ... 2093 kW
2 stages

- **Fuel:** heavy oil, viscosity 50°E at 50°C, Hi = 10,5...11,5 kWh/kg
- **Protection level:** IP 42 (IP54 on request)



TECHNICAL DATA

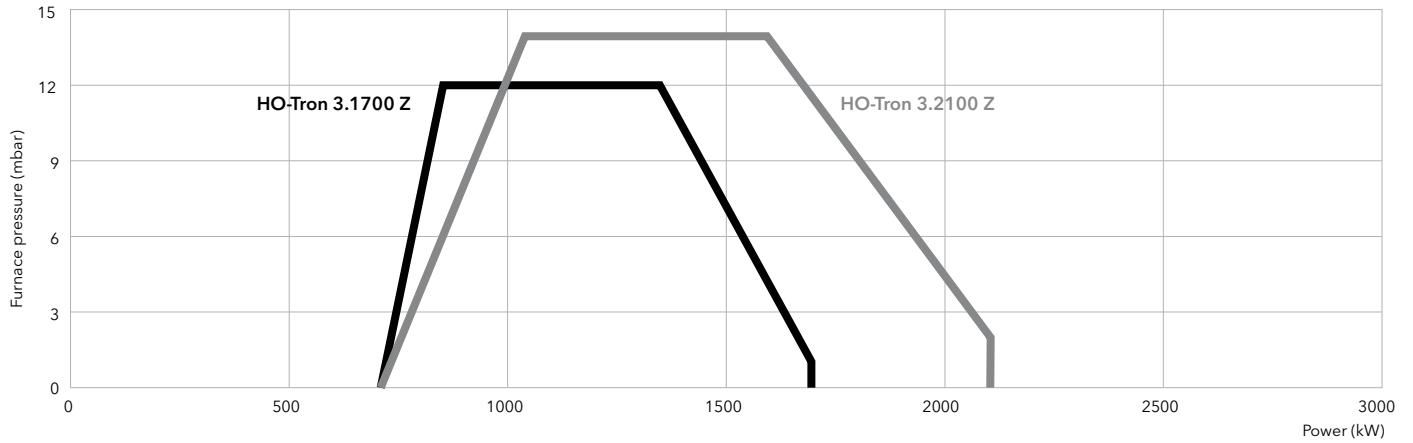

	HO-TRON 3.1700 Z		HO-TRON 3.2100 Z	
Operating range	682 - 1700 kW		682 - 2093 kW	
Fuel flow	60 - 148 kg/h		60 - 184 kg/h	
Nozzles	according to required power		according to required power	
Control box	LMO 44		LMO 44	
Fan motor	2800 rpm - 230/400 V - 50 Hz - 3 kW		2800 rpm - 230/400 V - 50 Hz - 4 kW	
Pump	E6 NC 1069		E6 NC 1069	
Resistance on pre-heaters	9 kW		10,5 kW	
Head lenght	KN	KL	KN	KL
Complete burner code	3142675	3143194	3142441	3142677



DIMENSIONS (mm)

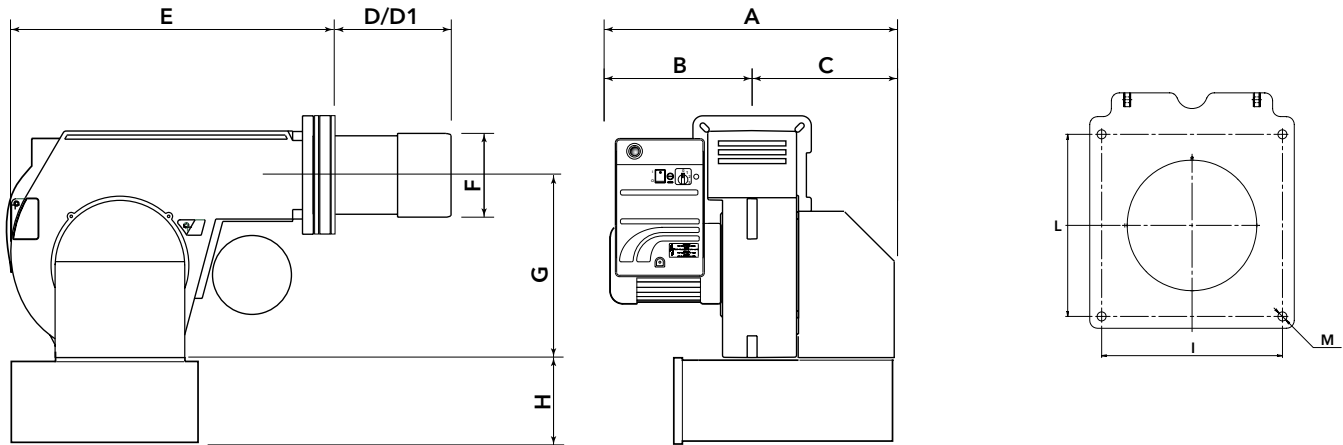

Model	A	B	C	D	D1	E	F	G	H*	I	L	M
HO-TRON 3.1700	920	450	470	280	480	710	250	420	260	315	315	M14
HO-TRON 3.2100	920	450	470	280	480	710	270	420	260	315	315	M14

* optional silencer

PACKAGING

The complete burner with combustion head is delivered in a single carton box with flexible hoses and operating manual including electrical terminal diagram and spare parts list.

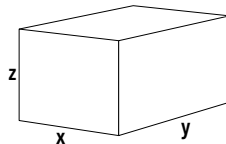

Models	Dimensions (mm)		
	X	Y	Z
HO-TRON 3	1370	1140	950

HO-TRON 4 Z/Z3

1000 ... 3900 kW
2 stages

- **Fuel:** heavy oil, viscosity 50°E at 50°C, Hi = 10,5...11,5 kWh/kg
- **Protection level:** IP 42 (IP54 on request)



TECHNICAL DATA

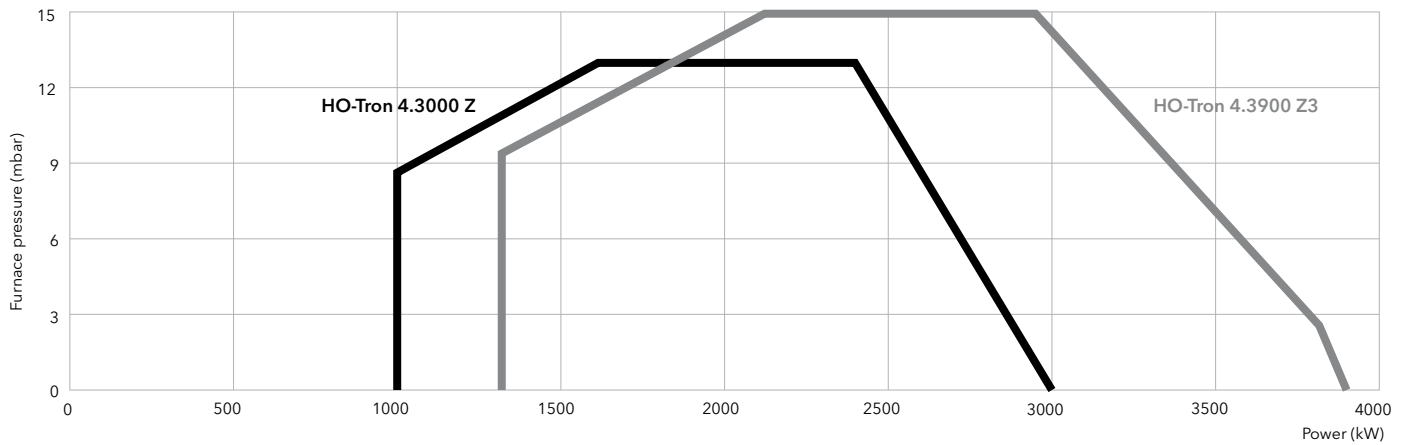

	HO-TRON 4.3000 Z		HO-TRON 4.3900 Z3	
Operating range	1000 - 3000 kW		1300 - 3900 kW	
Fuel flow	88,5 - 264 kg/h		115 - 343 kg/h	
Nozzles	according to required power		according to required power	
Control box	LMO 44		LMO 44	
Fan motor	2800 rpm - 230/400 V - 50 Hz - 7,5 kW		2800 rpm - 230/400 V - 50 Hz - 9 kW	
Pump	E7 NC 1069		E7 NC 1069	
Resistance on pre-heaters	18 kW		21 kW	
Head lenght	KN	KL	KN	KL
Complete burner code	3142678	3142679	3142680	3142681



DIMENSIONS (mm)

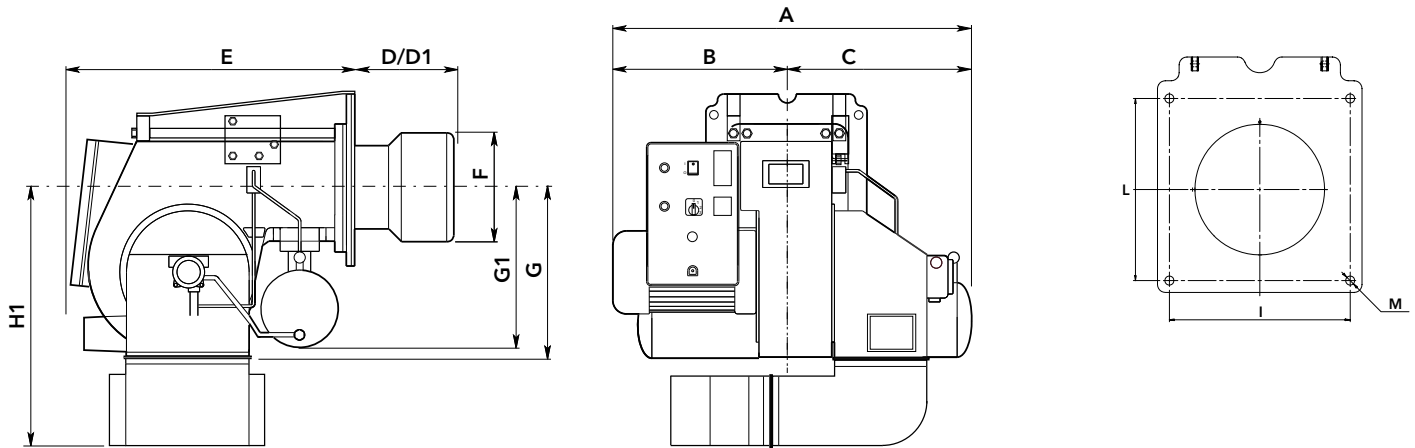

Model	A	B	C	D	D1	E	F	G	G1	H1*	I	L	M
HO-TRON 4.3000	1205	603	602	350	600	925	290	470	430	746	400	400	M16
HO-TRON 4.3900	1205	603	602	350	600	925	320	470	430	746	400	400	M16

* optional silencer

PACKAGING

The complete burner with combustion head is delivered in a single wooden box with flexible hoses and operating manual including electrical terminal diagram and spare parts list.

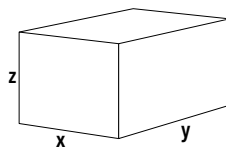

Models	Dimensions (mm)		
	X	Y	Z
HO-TRON 4	1580	1580	1050

HO-TRON 4 R

1000 ... 3900 kW

2 stage progressive/modulating mechanical

- **Fuel:** heavy oil, viscosity 50°E at 50°C, Hi = 10,5...11,5 kWh/kg
- **Protection level:** IP 42 (IP54 on request)



TECHNICAL DATA

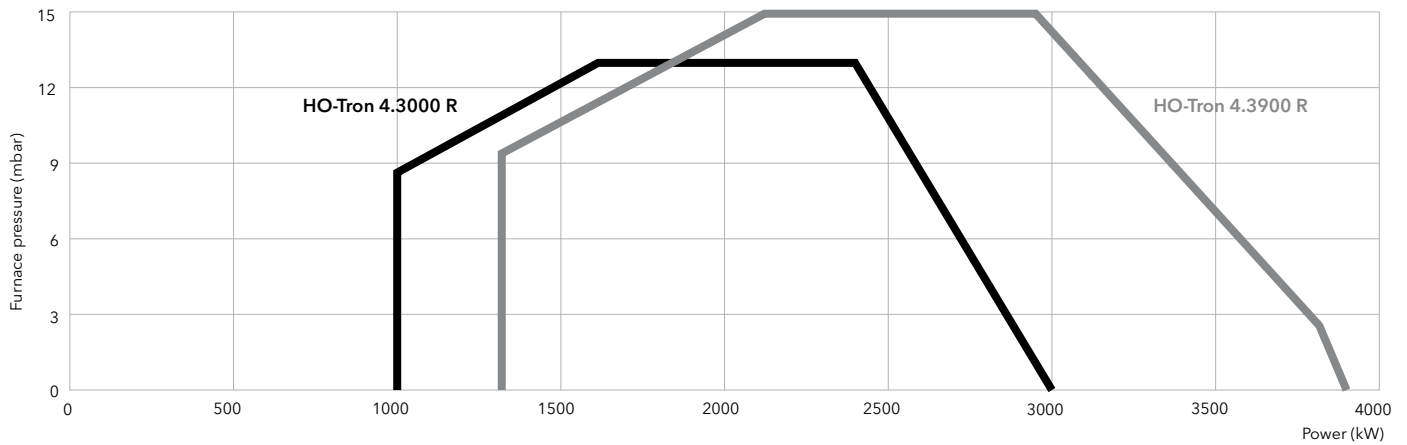

	HO-TRON 4.3000 R		HO-TRON 4.3900 R	
Operating range	1000 - 3000 kW		1300 - 3900 kW	
Fuel flow	88,5 - 264 kg/h		115 - 343 kg/h	
Nozzles	according to required power		according to required power	
Control box	LAL 1.25		LAL 1.25	
Fan motor	2800 rpm - 230/400 V - 50 Hz - 7,5 kW		2800 rpm - 230/400 V - 50 Hz - 9 kW	
Pump	TA 3C		TA 3C	
Resistance on pre-heaters	18 kW		21 kW	
Head lenght	KN	KL	KN	KL
Complete burner code	on request	on request	on request	on request



DIMENSIONS (mm)

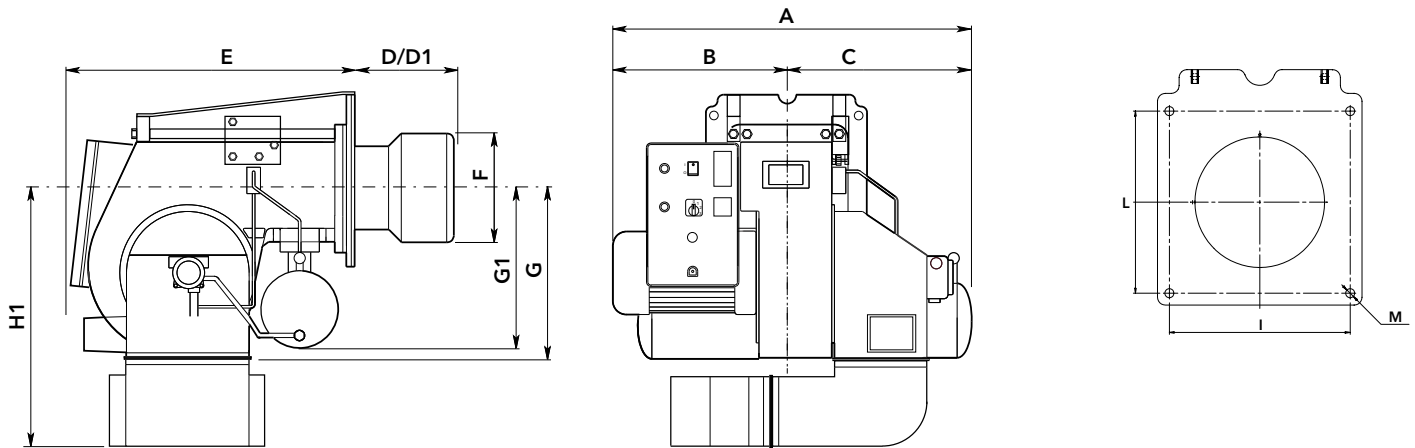

Model	A	B	C	D	D1	E	F	G	G1	H1*	I	L	M
HO-TRON 4.3000	1205	603	602	350	600	925	290	470	430	746	400	400	M16
HO-TRON 4.3900	1205	603	602	350	600	925	320	470	430	746	400	400	M16

* optional silencer

PACKAGING

The complete burner with combustion head is delivered in a single wooden box with flexible hoses and operating manual including electrical terminal diagram and spare parts list.

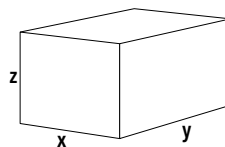

Models	Dimensions (mm)		
	X	Y	Z
HO-TRON 4 R	1580	1580	1050

HO-TRON 5 R

1578 ... 5800 kW

2 stage progressive/modulating mechanical

- **Fuel:** heavy oil, viscosity 50°E at 50°C, Hi = 10,5...11,5 kWh/kg
- **Protection level:** IP 42 (IP54 on request)



TECHNICAL DATA

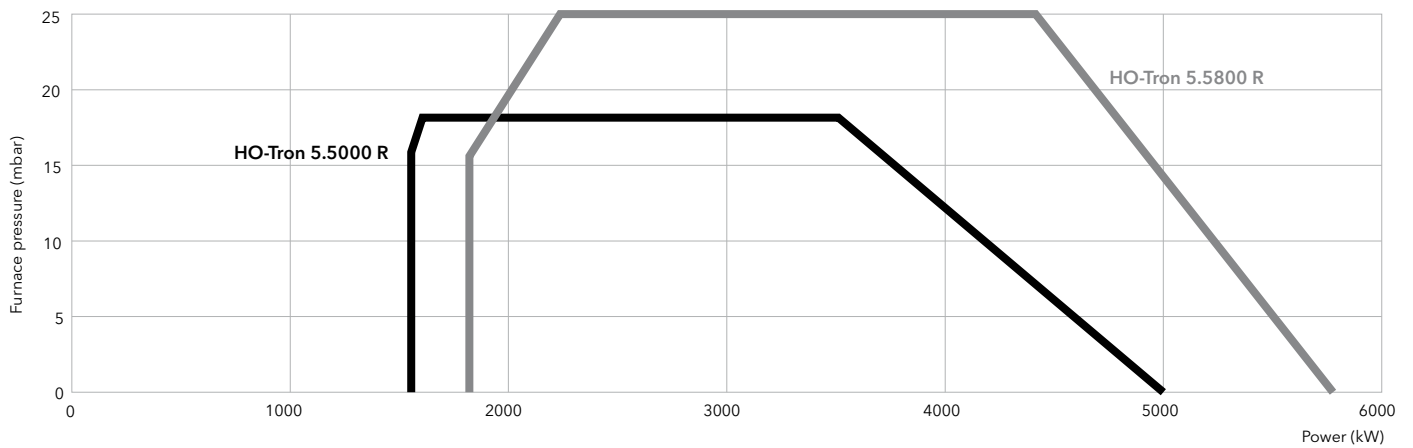

	HO-TRON 5.5000 R		HO-TRON 5.5800 R	
Operating range	1578 - 5000 kW		1795 - 5800 kW	
Fuel flow	140 - 440 kg/h		159 - 510 kg/h	
Nozzles	according to required power		according to required power	
Control box	LAL 1.25		LAL 1.25	
Fan motor	2800 rpm - 230/400 V - 50 Hz - 11 kW		2800 rpm - 230/400 V - 50 Hz - 15 kW	
Pump	TA 4C		TA 4C	
Resistance on pre-heaters	24 kW		24 kW	
Head lenght	KN	KL	KN	KL
Complete burner code	3143183	on request	on request	on request



DIMENSIONS (mm)

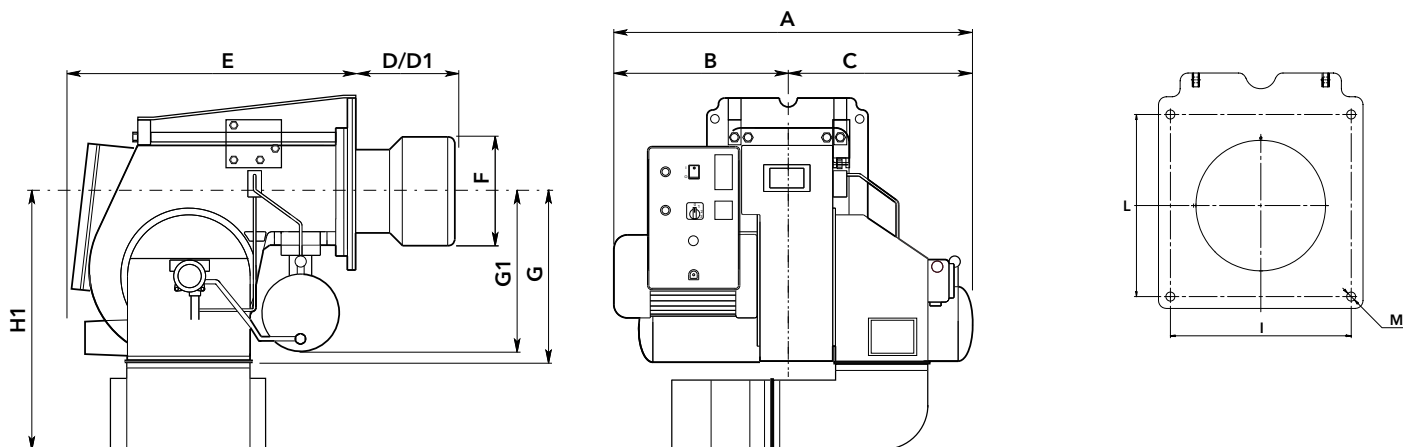

Model	A	B	C	D	D1	E	F	G	G1	H1	I	L	M
HO-TRON 5	1300	610	690	370	670	990	320	570	480	965	460	460	M16

* optional silencer

PACKAGING

The complete burner with combustion head is delivered in a single wooden box with flexible hoses and operating manual including electrical terminal diagram and spare parts list.

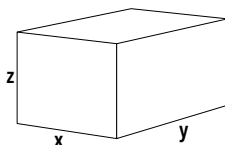

Models	Dimensions (mm)		
	X	Y	Z
HO-TRON 5 R	1580	1580	1050

HO-TRON 6 R

2417 ... 12500 kW

2 stage progressive/modulating mechanical

- **Fuel:** heavy oil, viscosity 50°E at 50°C, Hi = 10,5...11,5 kWh/kg
- **Protection level:** IP 42 (IP54 on request)



TECHNICAL DATA

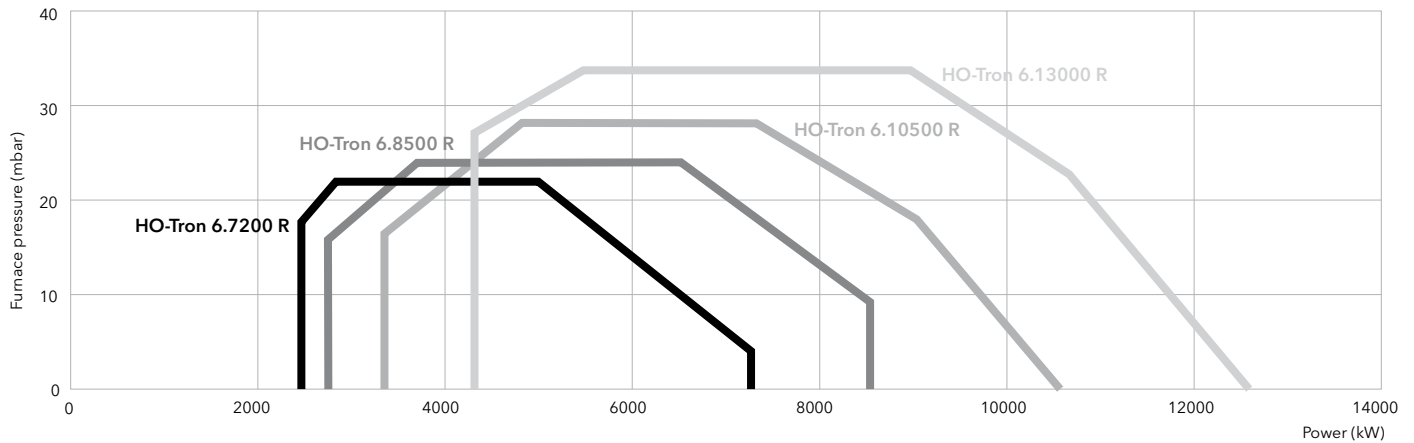

	HO-TRON 6.7200 R		HO-TRON 6.8500 R		HO-TRON 6.10500 R		HO-TRON 6.13000 R	
Operating range	2417 - 7500 kW		2750 - 8500 kW		3300 - 10500 kW		4367 - 12500 kW	
Fuel flow	214 - 660 kg/h		243 - 748 kg/h		292 - 924 kg/h		386 - 1099 kg/h	
Nozzles	according to required power		according to required power		according to required power		according to required power	
Control box	LAL 2.25		LAL 2.25		LAL 2.25		LAL 2.25	
Fan motor	2800 rpm - 230/400 V 50 Hz - 15 kW		2800 rpm - 230/400 V 50 Hz - 18,5 kW		2800 rpm - 230/400 V 50 Hz - 22 kW		2800 rpm - 230/400 V 50 Hz - 37 kW	
Pump	TA 5C		TA 5C		T5 + TV		T5 + TV	
Resistance on pre-heaters	30 kW		30 kW		44 kW		60 kW	
Head lenght	KN	KL	KN	KL	KN	KL	KN	KL
Complete burner code	on request	on request	3143166	on request	on request	on request	3142911	on request



DIMENSIONS (mm)

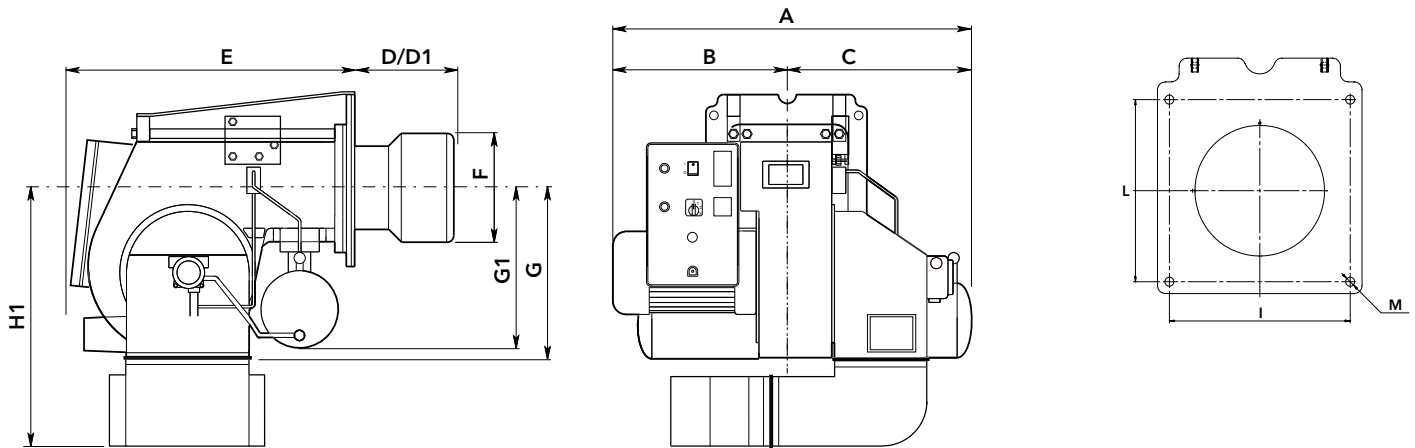

Model	A	B	C	D	E	F	G	G1	H1*	I	L	M
HO-TRON 6.7200	1390	660	730	525	1240	385	775	520	1270	460	460	M20
HO-TRON 6.8500	1480	660	820	535	1240	430	775	520	1270	460	460	M20
HO-TRON 6.10500	1505	685	820	535	1240	460	775	520	1270	460	460	M20
HO-TRON 6.13000	1750	800	950	535	1410	460	775	900	1270	460	460	M20

* optional silencer

PACKAGING

The complete burner with combustion head is delivered in a single wooden box with flexible hoses and operating manual including electrical terminal diagram and spare parts list.

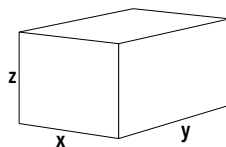

Models	Dimensions (mm)		
	X	Y	Z
HO-TRON 6 R	2400	1800	1600

HO-TRON 7 R

5000 ... 17000 kW

2 stage progressive/modulating mechanical

- **Fuel:** heavy oil, viscosity 50°E at 50°C, Hi = 10,5...11,5 kWh/kg
- **Protection level:** IP 42 (IP54 on request)

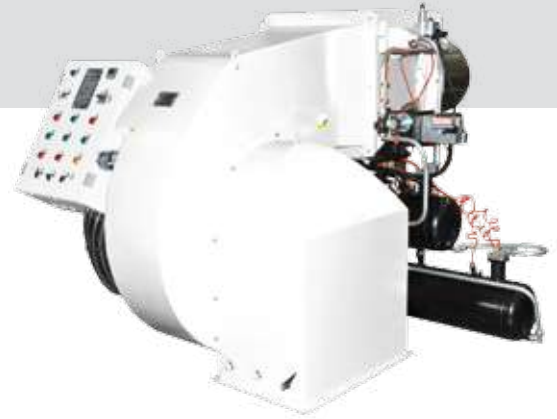

TECHNICAL DATA

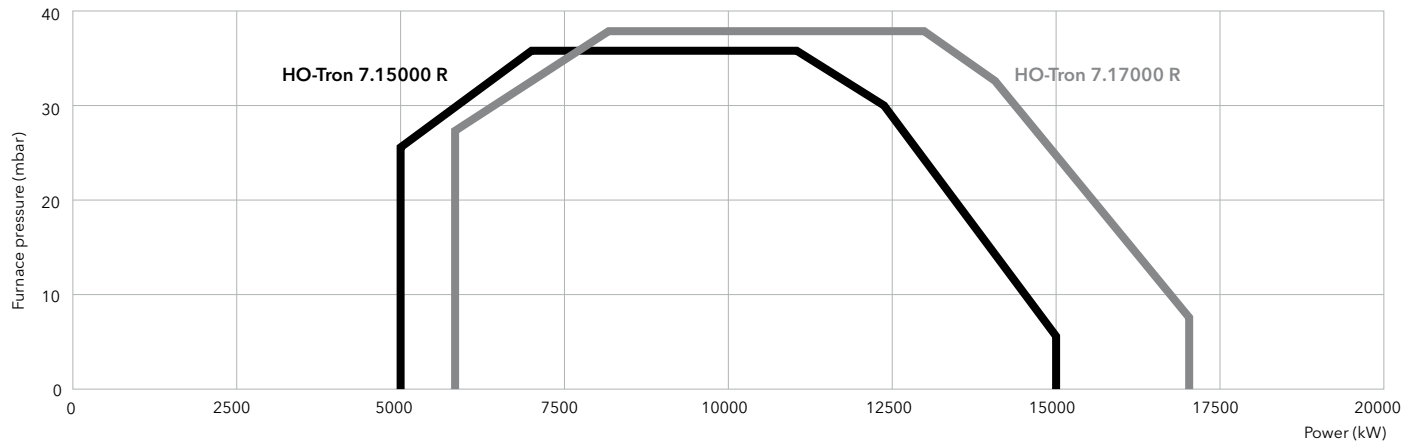

	HO-TRON 7.15000 R		HO-TRON 7.17000 R	
Operating range	5000 - 15000 kW		5700 - 17000 kW	
Fuel flow	440 - 1319 kg/h		500 - 1495 kg/h	
Nozzles	according to required power		according to required power	
Control box	LAL 1.25		LAL 1.25	
Fan motor	2800 rpm - 230/400 V - 50 Hz - 45 kW		2800 rpm - 230/400 V - 50 Hz - 55 kW	
Pump	T5 + TV		T5 + TV	
Resistance on pre-heaters	75 kW		75 kW	
Head lenght	KN	KL	KN	KL
Complete burner code	on request	on request	on request	on request



DIMENSIONS (mm)

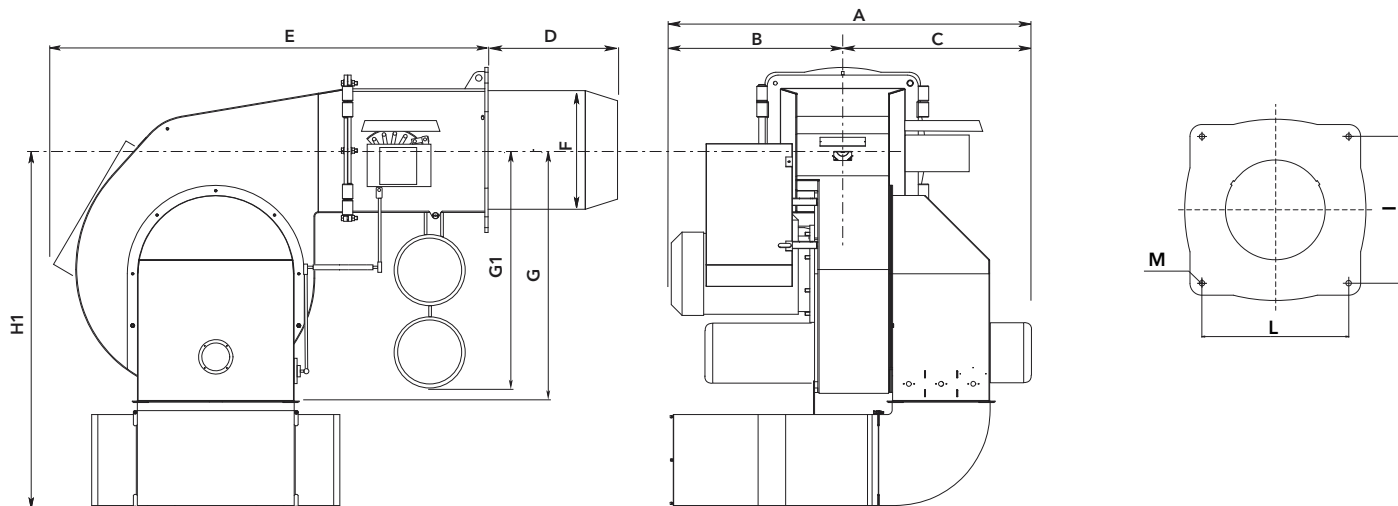

Model	A	B	C	D	E	F	G	G1	H1*	I	L	M
HO-TRON 7.15000	1700	800	900	590	1910	550	1320	1220	1670	620	620	M20
HO-TRON 7.17000	1770	870	900	590	1910	550	1320	1220	1670	620	620	M20

* optional silencer

PACKAGING

The complete burner with combustion head is delivered in a single wooden box with flexible hoses and operating manual including electrical terminal diagram and spare parts list.

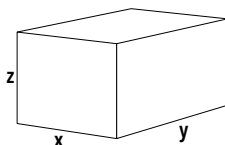

Models	Dimensions (mm)		
	X	Y	Z
HO-TRON 7 R	2800	2100	2000

Monoblock burners from 414 to 17000 kW Dual fuel (gas/heavy oil)

GHO-TRON burners are suitable to work with natural gas or heavy oil up to 50°E at 50°C.

This dual fuel range is available in two different configurations:

- two stage version with electric servomotor and integrated system for the regulation of air and fuel for the model GHO-TRON 3
- two stage progressive version with electrical servomotor and double adjustable mechanical cam that allows air and fuel fine tuning (for models up to 17 MW).



GHO-TRON burners feature an adjustable combustion head for easy regulation and matching with different combustion chambers.

All burners are characterized by easy access to the combustion component in order to simplify the maintenance operations.

All the models are fitted with special components for heavy oil combustion.

Models starting from GHO-TRON 3 are equipped with digital thermoregulator integrated on the front panel to grant temperature stability of the fuel. All the burners of the series have an heavy oil electric heating system on board and, starting from GHO-TRON 6, gas pilot included with separate supply line.

Configured and special version on request for selected type of applications and fuel characteristics.

MAIN TECHNICAL FEATURES

- Two stages and two stage progressive/modulating mechanical forced draught burners
- Electronic version available on request
- Fuels:
 - natural gas, Hi = 6,99 ... 11,39 kWh/Nm³
 - heavy oil, viscosity 50°E at 50°C, net calorific value 10,97 kWh/kg
- Two combustion head lengths available
- Gun type architecture:
 - separated forced draught fan;
 - optimal accessibility;
 - easy maintenance;
 - secured burner head adjustments;
 - closing of the air flap on burner shut-down
- Separated motor-pump on board
- Electrical heavy oil heater (oil supply to the burner at 80°C and 3 bar)
- Additional heating on the pipes and the valves, into the pump and the nozzle holder
- Closing of the air flap on burner shut-down
- Complete electrical equipment in a switch cabinet mounted on the burner with control panel
- Products are in compliance with EN267 and EN676 European standards and with the following directives:
 - 2014/35/UE Low Voltage Directive
 - 2014/30/UE EMC Directive
 - 2016/426/UE Gas Appliances Regulation
 - 2006/42/EC Machinery Directive
 - 2011/65/EU RoHS2 Directive

RANGE OVERVIEW

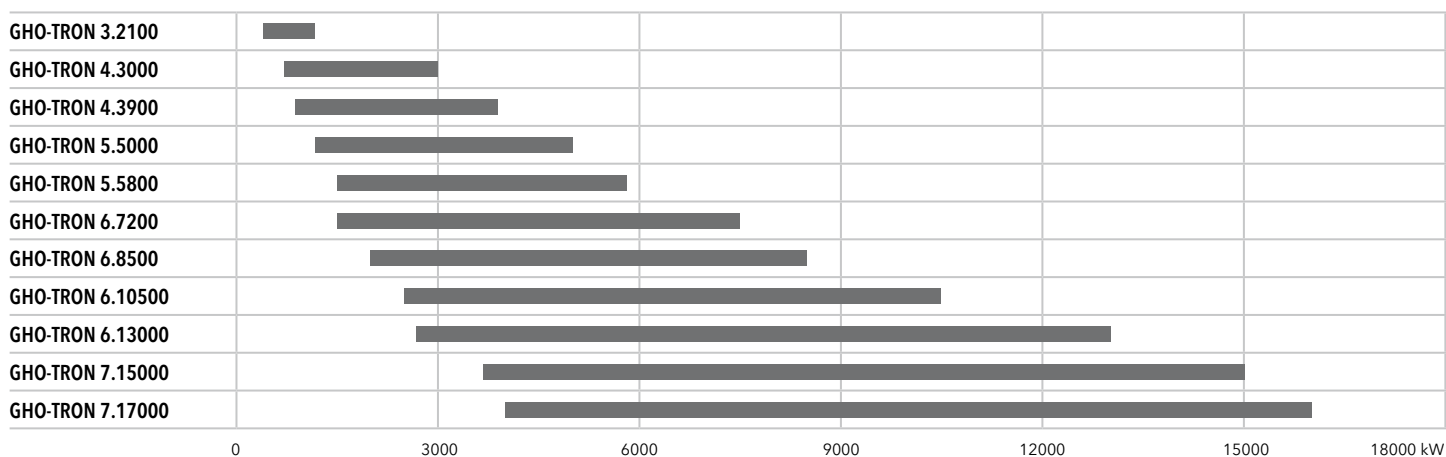

GHO-TRON 3 Z

414 ... 2150 kW

2 stages

- **Fuels:** natural gas, Hi = 6,99 ... 11,39 kWh/Nm³;
heavy oil, viscosity 50°E at 50°C, Hi = 10,5...11,5 kWh/kg
- **Emission class:** Low NOx class 2 (≤120 mg/kWh) according to EN676 in gas
- **Protection level:** IP 42 (IP54 on request)

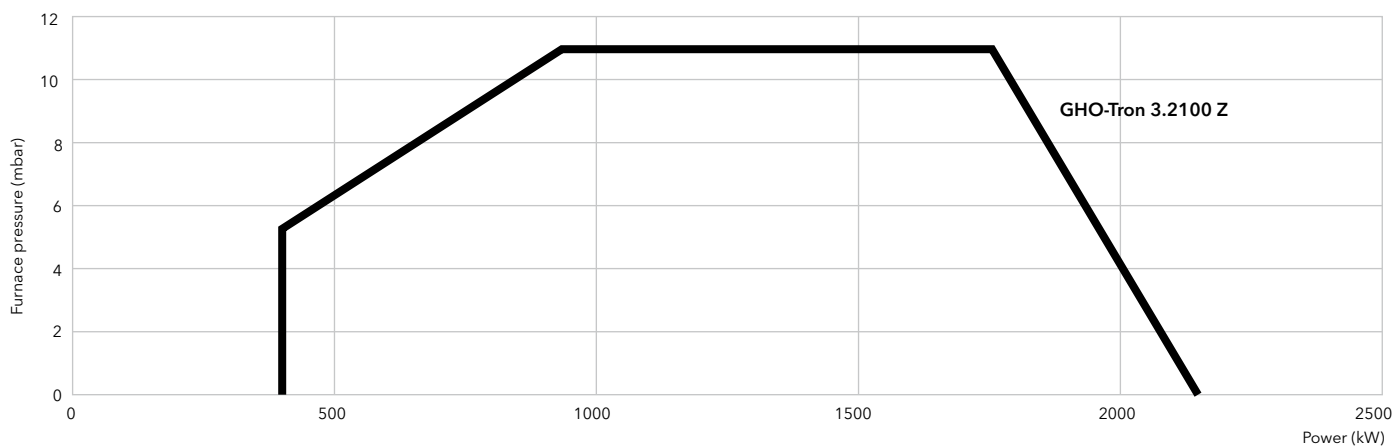
TECHNICAL DATA

GHO-TRON 3.2100 Z	
Operating range	414 - 2150 kW
Fuel flow	36 - 189 kg/h
Nozzles	according to required power
Control box	LGB 22
Fan motor	2800 rpm - 230/400 V - 50 Hz - 4 kW
Pump	E7 NC
Resistance on pre-heaters	10,5 kW
Head lenght	KN KL
Complete burner code	on request on request

i Dimensions of gas trains and gas filters: see pag. 210

DIMENSIONS (mm)

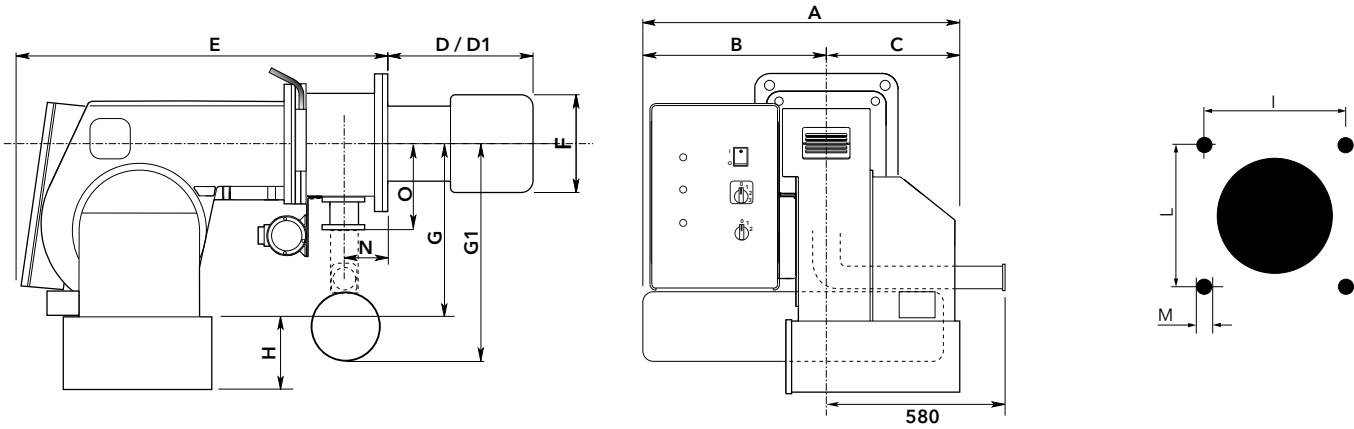

Model	A	B	C	D	D1	E	F	G	G1	H	N	O	I	L	M
GHO-TRON 3 Z	848	530	318	295	455	1150	270	395	600	283	125	250	315	315	M16

* optional silencer

PACKAGING

The complete burner with combustion head is delivered in a single carton box with flexible hoses and operating manual including electrical terminal diagram and spare parts list.

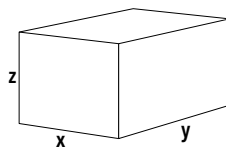

Models	Dimensions (mm)		
	X	Y	Z
GHO-TRON 3 Z	1370	1140	950

GHO-TRON 4 R

650 ... 3900 kW

2 stage progressive/modulating mechanical

- **Fuels:** natural gas, Hi = 6,99 ... 11,39 kWh/Nm³;
heavy oil, viscosity 50°E at 50°C, Hi = 10,5...11,5 kWh/kg
- **Emission class:** Low NOx class 2 (≤120 mg/kWh) according to EN676 in gas
- **Protection level:** IP 42 (IP54 on request)

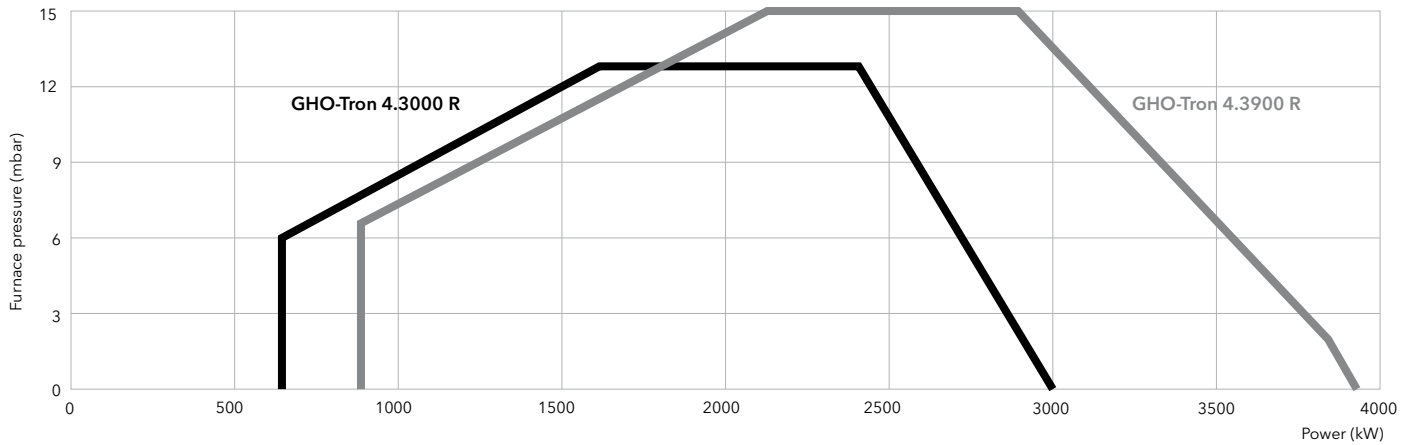
TECHNICAL DATA

	GHO-TRON 4.3000 R		GHO-TRON 4.3900 R	
Operating range	650 - 3000 kW		875 - 3900 kW	
Fuel flow	57 - 264 kg/h		77 - 343 kg/h	
Nozzles	according to required power		according to required power	
Control box	LFL 1.333		LFL 1.333	
Fan motor	2800 rpm - 230/400 V - 50 Hz - 7,5 kW		2800 rpm - 230/400 V - 50 Hz - 9 kW	
Pump	TA 3C		TA 3C	
Resistance on pre-heaters	18 kW		21 kW	
Head lenght	KN	KL	KN	KL
Complete burner code	on request	on request	on request	on request

i Dimensions of gas trains and gas filters: see pag. 210

DIMENSIONS (mm)

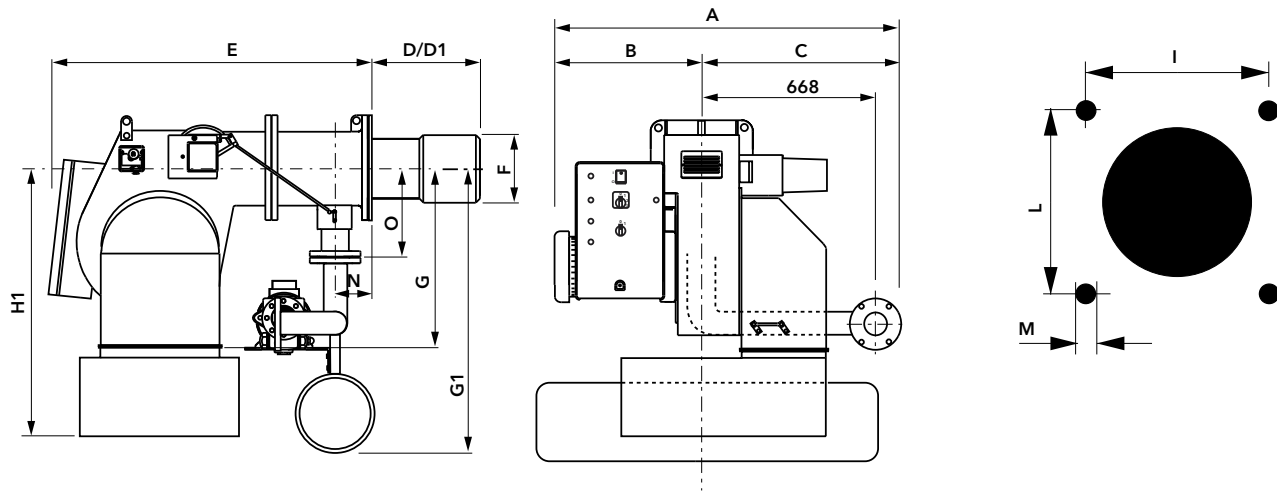

Model	A	B	C	D	D1	E	F	G	G1	H1*	N	O	I	L	M
GHO-TRON 4.3000 R	1288	610	678	330	530	1130	290	471	750	746	195	250	315	315	M16
GHO-TRON 4.3900 R	1288	610	678	345	545	1130	320	471	750	746	195	250	315	315	M16

* optional silencer

PACKAGING

The complete burner with combustion head is delivered in a single wooden box with flexible hoses and operating manual including electrical terminal diagram and spare parts list.

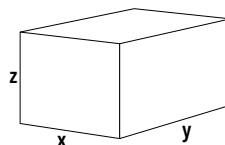

Models	Dimensions (mm)		
	X	Y	Z
GHO-TRON 4 R	1580	1580	1050

GHO-TRON 5 R

1200 ... 5800 kW

2 stage progressive/modulating mechanical

- **Fuels:** natural gas, Hi = 6,99 ... 11,39 kWh/Nm³;
heavy oil, viscosity 50°E at 50°C, Hi = 10,5...11,5 kWh/kg
- **Emission class:** Low NOx class 2 (≤120 mg/kWh) according to EN676 in gas
- **Protection level:** IP 42 (IP54 on request)



TECHNICAL DATA

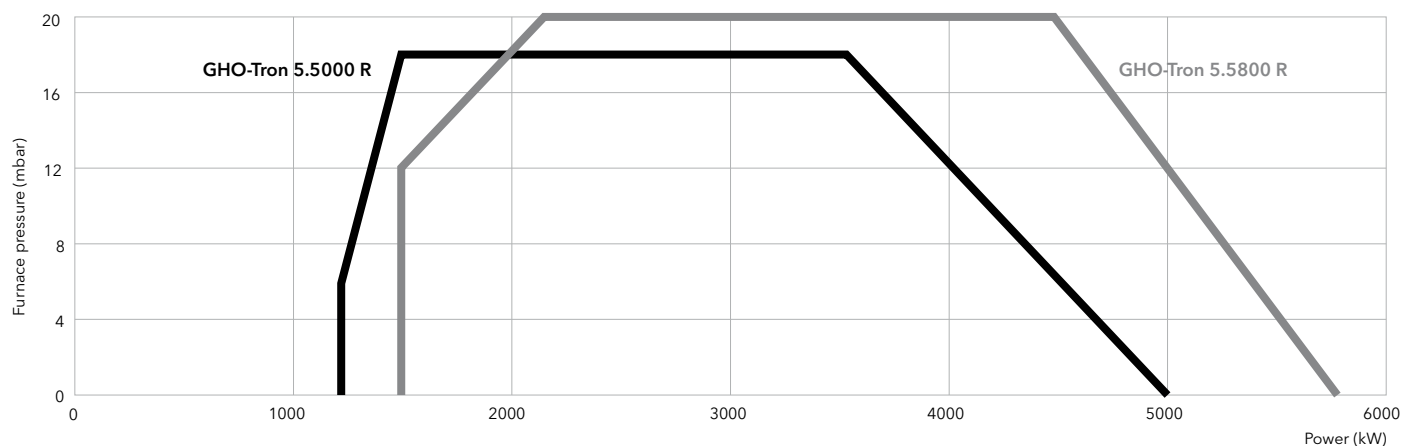

	GHO-TRON 5.5000 R		GHO-TRON 5.5800 R	
Operating range	1200 - 5000 kW		1500 - 5800 kW	
Fuel flow	106 - 440 kg/h		132 - 510 kg/h	
Nozzles	according to required power		according to required power	
Control box	LFL 1.333		LFL 1.333	
Fan motor	2800 rpm - 230/400 V - 50 Hz - 11 kW		2800 rpm - 230/400 V - 50 Hz - 15 kW	
Pump	TA 4C		TA 4C	
Resistance on pre-heaters	24 kW		24 kW	
Head lenght	KN	KL	KN	KL
Complete burner code	on request	on request	on request	on request

i Dimensions of gas trains and gas filters: see pag. 210

DIMENSIONS (mm)

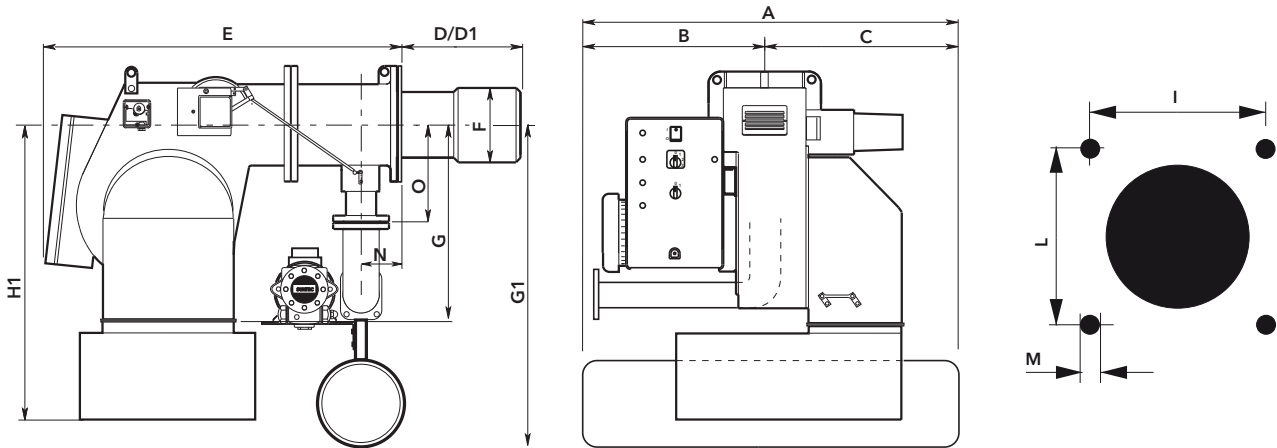

Model	A	B	C	D	D1	E	F	G	G1	H1*	N	O	I	L	M
GHO-TRON 5 R	1358	680	678	354	554	1230	320	570	775	965	195	250	330	330	M16

* optional silencer

PACKAGING

The complete burner with combustion head is delivered in a single wooden box with flexible hoses and operating manual including electrical terminal diagram and spare parts list.

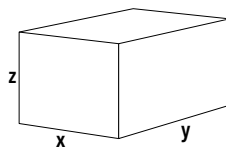

Models	Dimensions (mm)		
	X	Y	Z
GHO-TRON 5 R	1580	1580	1050

GHO-TRON 6 R

1500 ... 13000 kW

2 stage progressive/modulating mechanical

- **Fuels:** natural gas, Hi = 6,99 ... 11,39 kWh/Nm³;
heavy oil, viscosity 50°E at 50°C, Hi = 10,5...11,5 kWh/kg
- **Emission class:** Low NOx class 2 (≤120 mg/kWh) according to EN676 in gas
- **Protection level:** IP 42 (IP54 on request)



TECHNICAL DATA

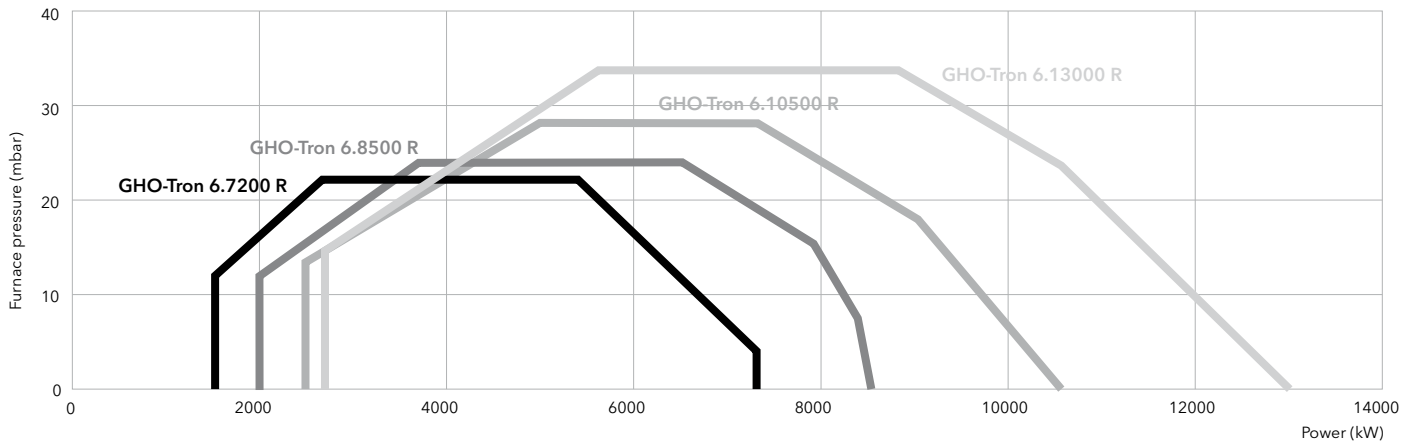

	GHO-TRON 6.7200 R		GHO-TRON 6.8500 R		GHO-TRON 6.10500 R		GHO-TRON 6.13000 R	
Operating range	1500 - 7500 kW		2000 - 8500 kW		2500 - 10500 kW		2700 - 13000 kW	
Fuel flow	132 - 660 kg/h		176 - 750 kg/h		220 - 920 kg/h		240 - 1100 kg/h	
Nozzles	according to required power		according to required power		according to required power		according to required power	
Control box	LFL 1.333		LFL 1.333		LFL 1.333		LFL 1.333	
Fan motor	2800 rpm - 230/400 V 50 Hz - 15 kW		2800 rpm - 230/400 V 50 Hz - 18,5 kW		2800 rpm - 230/400 V 50 Hz - 22 kW		2800 rpm - 230/400 V 50 Hz - 37 kW	
Pump	TA 5C		TA 5C		T5 + TV		T5 + TV	
Resistance on pre-heaters	30 kW		30 kW		44 kW		60 kW	
Head lenght	KN	KL	KN	KL	KN	KL	KN	KL
Complete burner code	on request	on request	on request	on request	on request	on request	on request	on request

i Dimensions of gas trains and gas filters: see pag. 210

DIMENSIONS (mm)

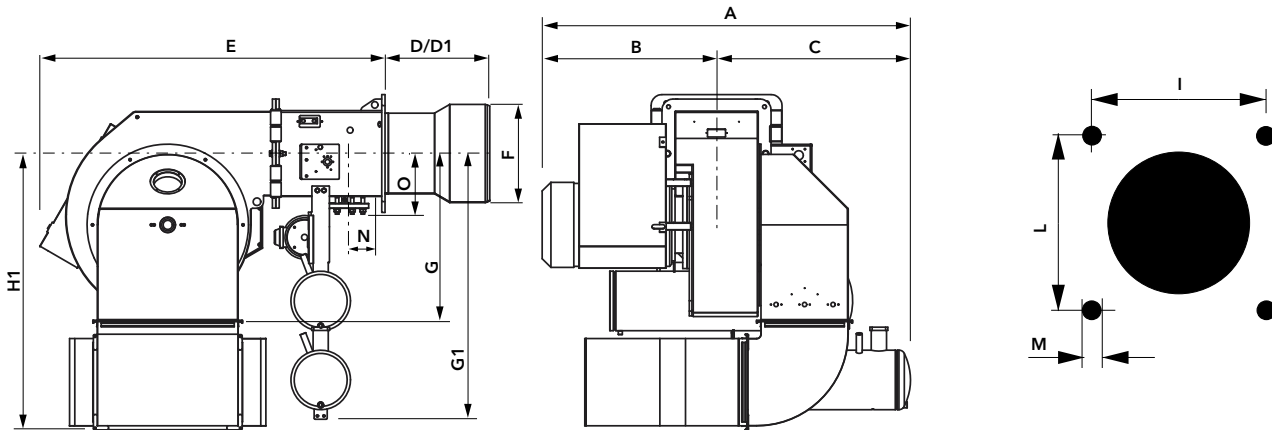

Model	A	B	C	D	E	F	G	G1	H1*	N	O	I	L	M
GHO-TRON 6.7200 R	1370	740	630	470	1640	420	775	850	1270	195	232	460	460	M20
GHO-TRON 6.8500 R	1370	740	630	470	1640	420	775	850	1270	195	232	460	460	M20
GHO-TRON 6.10500 R	1500	740	760	470	1640	420	775	850	1270	195	232	460	460	M20
GHO-TRON 6.13000 R	1700	800	900	470	1640	450	775	1200	1270	195	232	460	460	M20

* optional silencer

PACKAGING

The complete burner with combustion head is delivered in a single wooden box with flexible hoses and operating manual including electrical terminal diagram and spare parts list.

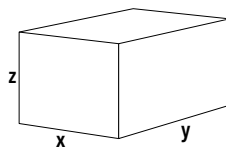

Models	Dimensions (mm)		
	X	Y	Z
GHO-TRON 6 R	2400	1800	1600

GHO-TRON 7 R

3690 ... 17000 kW

2 stage progressive/modulating mechanical

- **Fuels:** natural gas, Hi = 6,99 ... 11,39 kWh/Nm³;
heavy oil, viscosity 50°E at 50°C, Hi = 10,5...11,5 kWh/kg
- **Emission class:** Low NOx class 2 (≤120 mg/kWh) according to EN676 in gas
- **Protection level:** IP 42 (IP54 on request)

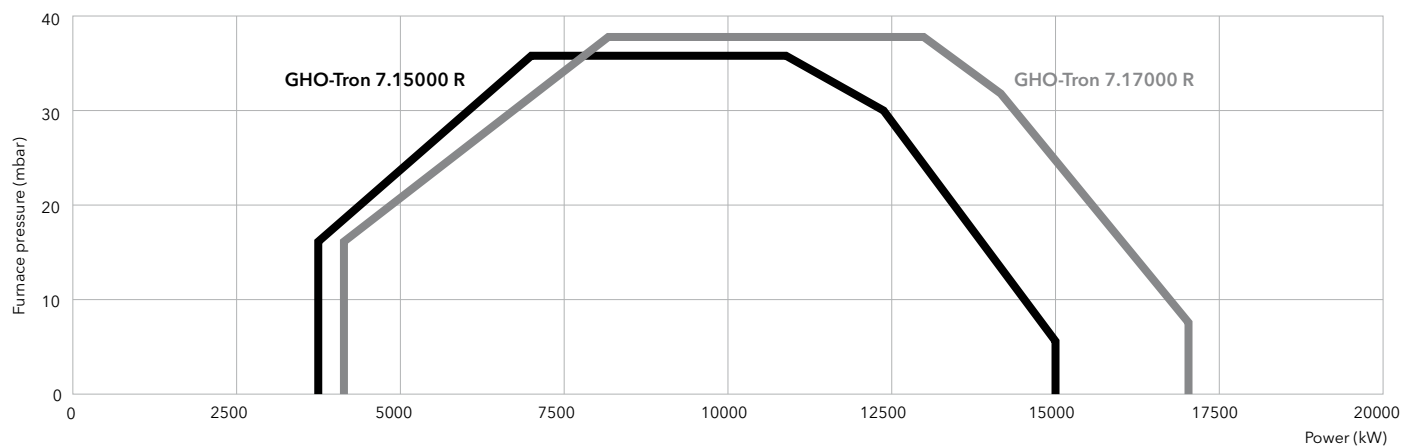
TECHNICAL DATA

	GHO-TRON 7.15000 R		GHO-TRON 7.17000 R	
Operating range	3690 - 15000 kW		4000 - 17000 kW	
Fuel flow	325 - 1320 kg/h		350 - 1495 kg/h	
Nozzles	according to required power		according to required power	
Control box	LFL 1.333		LFL 1.333	
Fan motor	2800 rpm - 230/400 V - 50 Hz - 45 kW		2800 rpm - 230/400 V - 50 Hz - 55 kW	
Pump	T5 + TV		T5 + TV	
Resistance on pre-heaters	75 kW		75 kW	
Head lenght	KN	KL	KN	KL
Complete burner code	on request	on request	on request	on request

i Dimensions of gas trains and gas filters: see pag. 210

DIMENSIONS (mm)

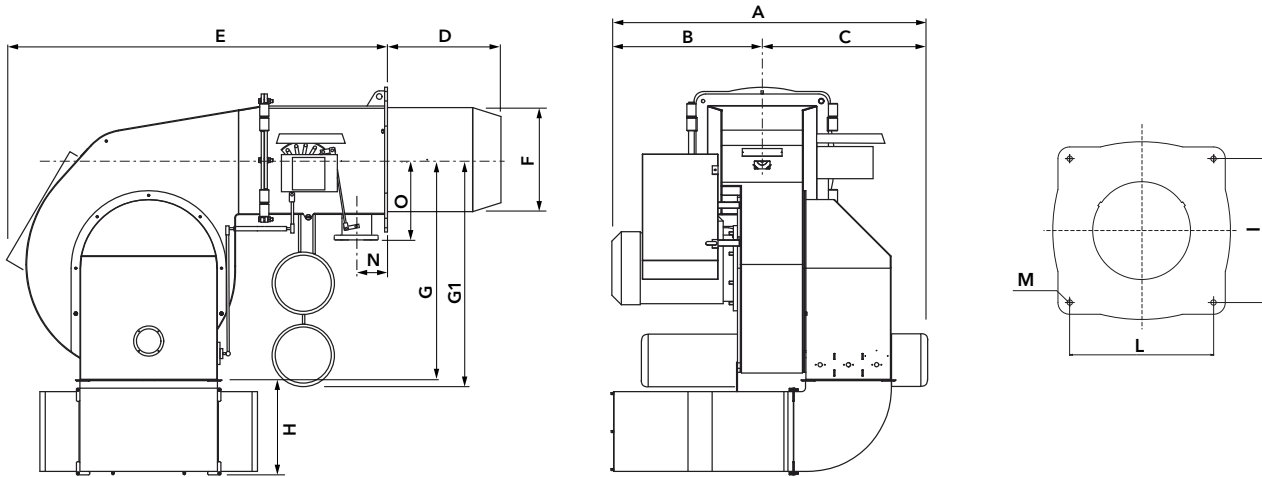

Model	A	B	C	D	E	F	G	G1	H*	N	O	I	L	M
GHO-TRON 7 R	1948	860	1088	590	1910	550	1167	1220	530	210	320	620	620	M20

* optional silencer

PACKAGING

The complete burner with combustion head is delivered in a single wooden box with flexible hoses and operating manual including electrical terminal diagram and spare parts list.

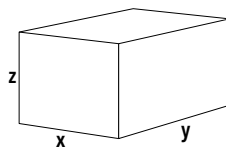

Models	Dimensions (mm)		
	X	Y	Z
GHO-TRON 7 R	2800	2100	2000

Duoblock burners from 230 to 80000 kW Gas, light oil, heavy oil and dual fuel operation

All the benefits of the separate ventilation

In contrast to monoblock burners, duoblock burners are made up of two units, or blocks, as the name implies: the burner head with the air inlet, and the separately-installed fan; the two units are connected via an air duct.



The separate installation of the fan offers several benefits:

- the fan can be installed in a separate room, for instance in the cellar; this results in considerably lower noise levels in the boiler room; when the fan is installed in the same room, a fan enclosure can be used to achieve optimum sound absorption, without inhibiting access to the burner;
- less space required in front of the boiler and in the combustion chamber;
- individual fan layout with optimum adaptation of the fan characteristic curve to suit the pressure ratio of the heat generator; this guarantees pulsation-free and stable burner behaviour, even on heat generators with high resistance on the exhaust side;
- combustion air can be pre-heated to increase installation efficiency;
- lower weight loading on the boiler front.

ELCO duoblock burners are designed to satisfy the widest range of needs and can be applied to the most various type of civil and industrial solutions like fire-tube boilers, water-tube boilers, dryers and melting furnaces.

These burners enable installation to realize a modular and flexible combustion solution with a high degree of personalization. This results in a high performance installations at the lowest running cost.

The burners are built to be connected to an external air supply and can be supplied together with built-in or separate control panel, electronic or mechanical adjustment, flue gas recirculation, heavy oil pump unit and heating unit.

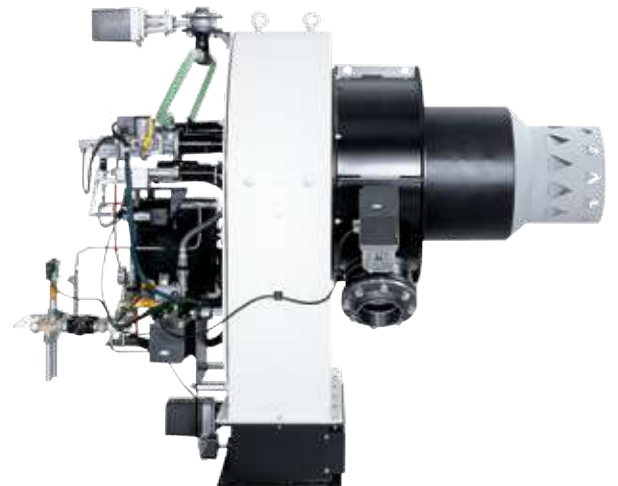

ELCO is able to offer an extremely wide range of industrial duoblock burners thanks to three different series, EK-DUO, RPD and D-TRON, covering a power range from 230 kW up to 80 MW.

This range of burners is able to fulfill high capacity and high turndown needs and allows installation in very high pressurized combustion chambers.

All duoblock models can work with pre-heated combustion air up to 200°C and can be used in order to achieve greater values of efficiency.

D-TRON

MAIN TECHNICAL FEATURES

- Two stages and progressive/modulating forced draught burners, designed to be connected to an external air supply
- Fuels:
 - natural gas, Hi = 6,99 ... 11,39 kWh/Nm³;
 - light oil, viscosity 6 mm²/s at 20°C, Hi = 11,86 kWh/kg;
 - heavy oil, viscosity 20...350 mm²/s at 50°C;
 - other fuels on request;
- Electrical switch cabinet manufactured in different configurations assembled on the burner or delivered separately and includes the burner control:
 - control box for burner operation sequences;
 - contactors and remote overload cut-out for control of the fan unit;
 - fuse to protect the auxiliary equipment;
 - switches, warning and information lights, manual power control;
 - ready to accept PID power regulator (option)
- Gas train factory assembled and tested for tightness and electrical security
- Electronic version available on request
- Products are in compliance with EN 267 and EN 676 European standards

EK-DUO

MAIN TECHNICAL FEATURES

- Progressive/modulating forced draught burners, designed to be connected to an external air supply
- Fuels:
 - natural gas, Hi = 6,99 ... 11,39 kWh/Nm³
 - light oil, viscosity 6 mm²/s at 20°C, Hi = 11,86 kWh/kg
 - other fuels on request
- Flame tube length according to installation
- Secured burner head adjustments during maintenance
- Closing of the air damper on burner shutdown
- Control box: built-in or external according to customer requirements
- Gas train factory assembled and tested for tightness and electrical security
- Products are in compliance with EN 267 and EN 676 European standards

RPD

MAIN TECHNICAL FEATURES

- Progressive/modulating forced draught burner with register, designed to be connected to an external air supply
- Fuels:
 - natural gas, Hi = 6,99 ... 11,39 kWh/Nm³;
 - light oil, viscosity 6 mm²/s at 20°C, Hi = 11,86 kWh/kg;
 - heavy oil, viscosity 20...350 mm²/s at 50°C;
 - other fuels on request;
 - co-combustion of various fuels or to eliminate liquid waste on request
- Air/gas ratio with Etamatic digital control box or with mechanical compound
- Adjustable flame length with air registers
- Flame tube length according to installation
- Closing of the air damper on burner shutdown
- Control box: built-in or external according to customer requirements
- Gas train factory assembled and tested for tightness and electrical security
- Products are in compliance with EN267 and EN676 European standards

DUOBLOCK RANGE

D-TRON

230 ... 34000 kW

2 stages and 2 stage progressive/modulating mechanical or electronic

- **Fuels:** - natural gas, Hi = 6,99 ... 11,39 kWh/Nm³;
- light oil, viscosity 6 mm²/s at 20°C, Hi = 11,86 kWh/kg;
- heavy oil, viscosity 20...350 mm²/s at 50°C;
- other fuels on request;
- **Protection level:** IP 41 (IP 54 and IP 65 on request)



RANGE OVERVIEW

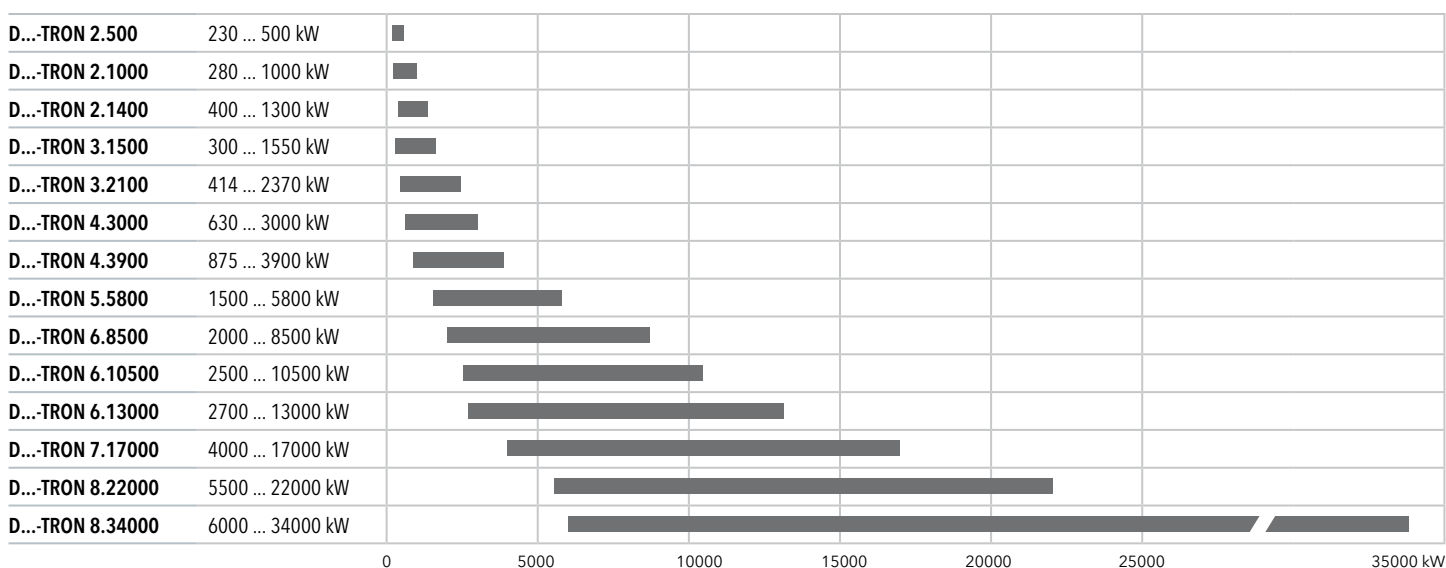

AVAILABLE CONFIGURATIONS

Model	Fuel					Operation		
	Gas DG-TRON	Gas/light oil DGL-TRON	Light oil DL-TRON	Heavy oil DO-TRON	Gas/heavy oil DGO-TRON	2 stages	Mechanical	Electronic
D...-TRON 2.500	●					●	●	
D...-TRON 2.1000	●	●				●	●	●
D...-TRON 2.1400		●				●		
D...-TRON 3.1500	●						●	
D...-TRON 3.2100	●	●	●	●		●	●	●
D...-TRON 4.3000	●	●	●	●	●		●	●
D...-TRON 4.3900	●	●	●	●	●		●	●
D...-TRON 5.5800	●	●	●	●	●		●	●
D...-TRON 6.8500	●	●	●	●	●		●	●
D...-TRON 6.10500	●	●	●	●	●		●	●
D...-TRON 6.13000	●	●	●	●	●		●	●
D...-TRON 7.17000	●	●	●	●	●		●	●
D...-TRON 8.22000	●	●	●	●	●		●	●
D...-TRON 8.34000	●	●	●	●	●		●	●

DIMENSIONS (mm)

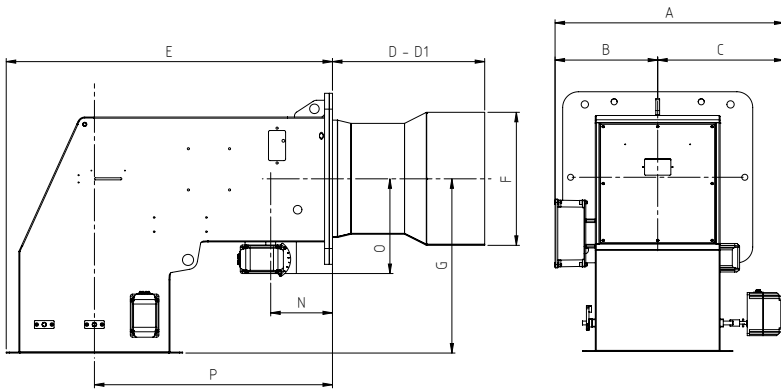

Connecting flange

D...-TRON 2...6

D...-TRON 7-8

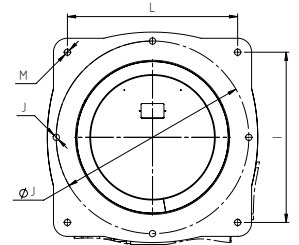
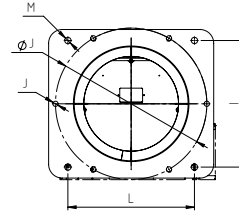

Model	A	B	C	D	D1	E	F	G	I	L	M	ØJ	J	N	O	P
D...-TRON 2.500	523	216	307	174	394	556	160	290	190	190	4xM10	-	-	139	175*	405
D...-TRON 2.1000	523	216	307	174	394	556	190	290	190	190	4xM10	-	-	139	175*	405
D...-TRON 2.1400	523	216	307	342	492	556	200	290	190	190	4xM10	-	-	139	175*	405
D...-TRON 3.1500	523	216	307	342	492	556	200	290	190	190	4xM10	-	-	139	175*	405
D...-TRON 3.2100	543	234	309	348	548	620	270	375	270	270	4xM16	-	-	125	250	448
D...-TRON 4.3000	605	265	340	330	530	728	290	392	315	315	4xM16	-	-	188	250	528
D...-TRON 4.3900	605	265	340	365	565	728	320	392	315	315	4xM16	-	-	188	250	528
D...-TRON 5.5800	617	271	346	373	573	810	360	404	330	330	4xM16	-	-	195	250	575
D...-TRON 6.8500	723	324	399	470	-	1030	420	550	460	460	4xM20	550	4xM16	195	299	752
D...-TRON 6.10500	723	324	399	470	-	1030	420	550	460	460	4xM20	550	4xM16	195	299	752
D...-TRON 6.13000	723	324	399	470	-	1030	450	550	460	460	4xM20	550	4xM16	195	299	752
D...-TRON 7.17000	899	412	487	590	-	1480	551	670	619	619	4xM20	700	4xM20	200	390	1115
D...-TRON 8.22000	1080	501	579	530	-	1549	626	760	800	800	4xM20	1130	4xM20	210	412	1084
D...-TRON 8.34000	1080	501	579	530	-	1549	626	760	800	800	4xM20	1130	4xM20	210	412	1084

Air duct

D...-TRON 2-3

D...-TRON 4-5

D...-TRON 6

D...-TRON 7

D...-TRON 8

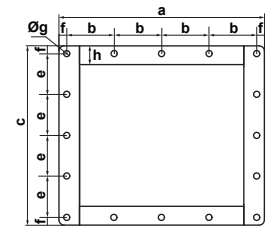
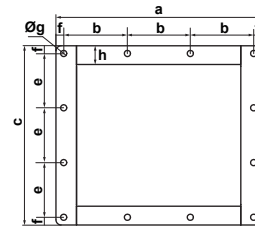
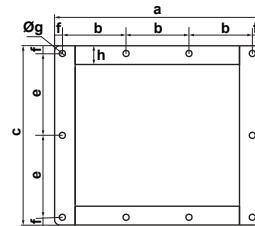
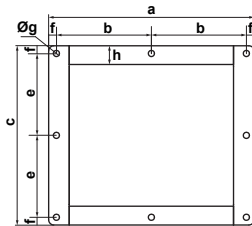
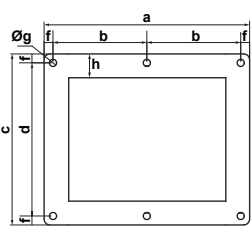

Model	a	b	c	d	e	f	Øg	h
D...-TRON 2.500	303	136,5	252	222	-	15	6x R12	40
D...-TRON 2.1000	303	136,5	252	222	-	15	6x R12	40
D...-TRON 2.1400	303	136,5	252	222	-	15	6x R12	40
D...-TRON 3.1500	303	136,5	252	222	-	15	6x R12	40
D...-TRON 3.2100	345	157,5	287	257	-	15	6x R12	40
D...-TRON 4.3000	400	185	349	-	159,5	15	8x R12	40
D...-TRON 4.3900	400	185	349	-	159,5	15	8x R12	40
D...-TRON 5.5800	470	220	361	-	165,5	15	8x R12	40
D...-TRON 6.8500	557	173	474	-	218	19	10x R14	43
D...-TRON 6.10500	557	173	474	-	218	19	10x R14	43
D...-TRON 6.13000	557	173	474	-	218	19	10x R14	43
D...-TRON 7.17000	730	230,7	650	-	204	19	12x R14	43
D...-TRON 8.22000	930	223	828	-	197,5	19	16x R14	40
D...-TRON 8.34000	930	223	828	-	197,5	19	16x R14	40

DUOBLOCK RANGE

EK-DUO

600 ... 16000 kW

2 stage progressive/modulating electronic

- **Fuels:** - natural gas, Hi = 6,99 ... 11,39 kWh/Nm³;
- light oil, viscosity 6 mm²/s at 20°C, Hi = 11,86 kWh/kg;
- other fuels on request
- **Emission class:** - Low NOx class 3 (≤80 mg/kWh) according to EN676 in gas and
- Low NOx class 3 (≤120 mg/kWh) according to EN267 in light oil
- **Protection level:** IP 41 (IP 54 and IP 65 on request)

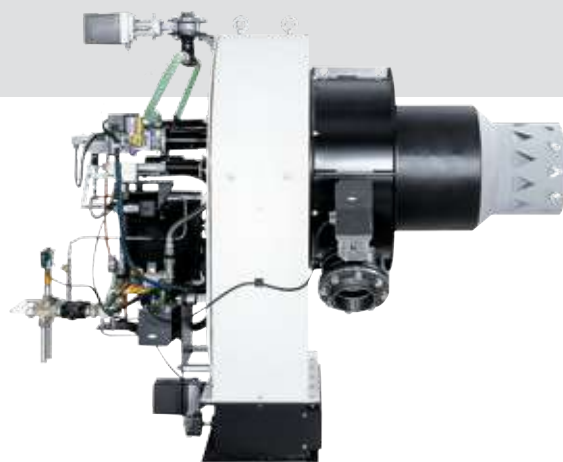

RANGE OVERVIEW

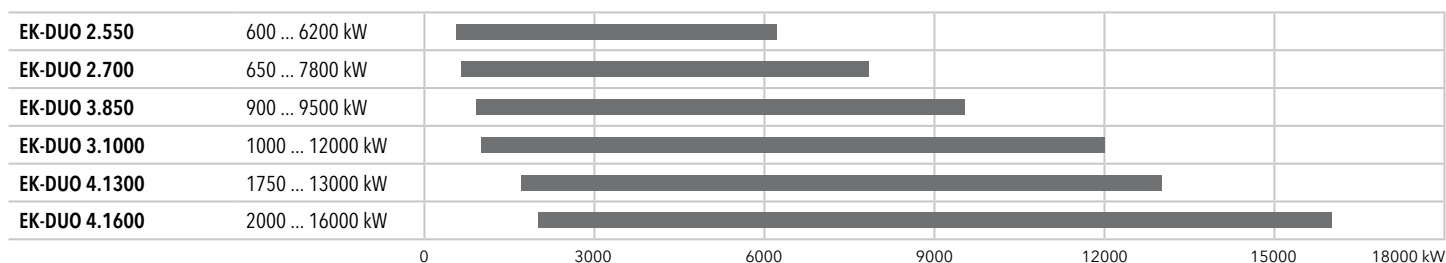

AVAILABLE CONFIGURATIONS

Model	Weight (kg)	Fuel					Operation	
		Gas	Gas/Light oil	Light oil	Heavy oil	Gas/Heavy oil	Mechanical	Electronic
EK-DUO 2.550	320 ... 400	●	●	●				●
EK-DUO 2.700	320 ... 400	●	●	●				●
EK-DUO 3.850	400 ... 470	●	●	●				●
EK-DUO 3.1000	400 ... 470	●	●	●				●
EK-DUO 4.1300	400 ... 420	●	●	●				●
EK-DUO 4.1600	400 ... 420	●	●	●				●



DIMENSIONS (mm)

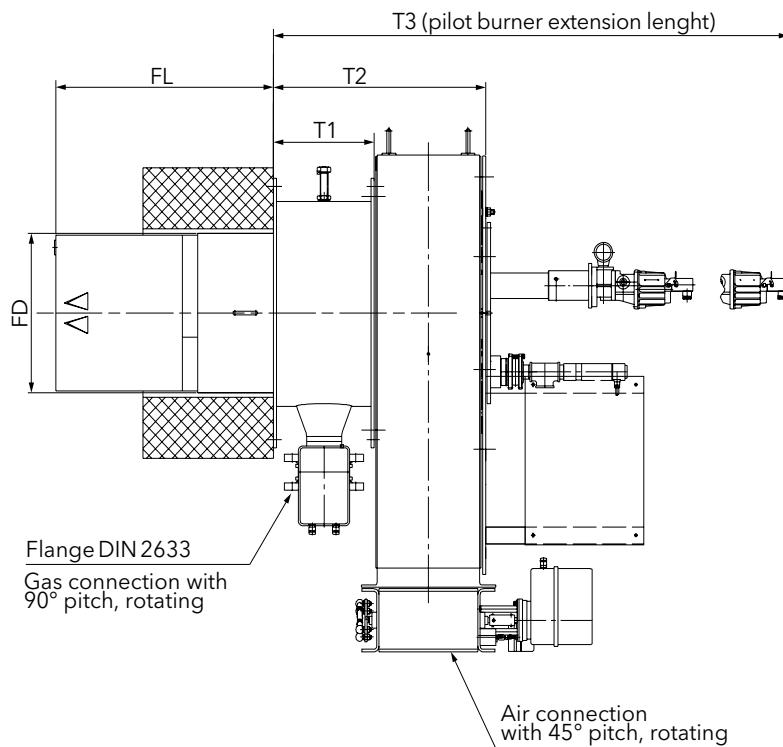
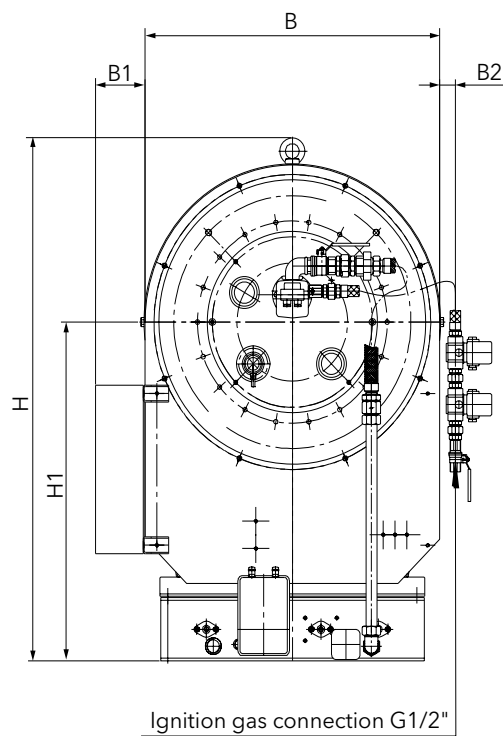

Air connection flange

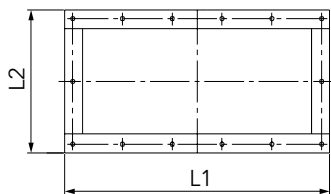

Details of boiler front plate

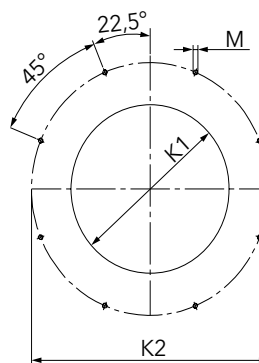

Model	Gas connection	H	H1	B	B1	B2*	T1	T2	T3*	FL*	FD*	L1	L2	K1	K2	M
EK-DUO 2.550	DN80	1241	804	750	125	40	255	537	2005 ... 2150	320 ... 570	378	670	340	400	600	M12
EK-DUO 2.700	DN80	1241	804	750	125	40	255	537	2005 ... 2150	320 ... 570	378	670	340	400	600	M12
EK-DUO 3.850	DN80	1481	944	950	120	40	290	622	1810 ... 2390	350 ... 590	441 ... 456	827	386	480	690	M12
EK-DUO 3.1000	DN80	1481	944	950	120	40	290	622	1810 ... 2390	350 ... 590	441 ... 456	827	386	480	690	M12
EK-DUO 4.1300	DN100	1491	929	1000	122	40	420	802	2600 ... 2770	350 ... 620	506	840	440	525	725	M20
EK-DUO 4.1600	DN100	1491	929	1000	122	40	420	802	2600 ... 2770	350 ... 620	506	840	440	525	725	M20

*: values are referred to standard burner versions and may vary in base of the configuration chosen

DUOBLOCK RANGE

RPD

500 ... 80000 kW

2 stage progressive/modulating mechanical or electronic

- **Fuels:** - natural gas, Hi = 6,99 ... 11,39 kWh/Nm³;
- light oil, viscosity 6 mm²/s at 20°C, Hi = 11,86 kWh/kg;
- heavy oil, viscosity 20...350 mm²/s at 50°C;
- other fuels on request;
- co-combustion of various fuels or to eliminate liquid waste on request
- **Emission class:** - Low NOx class 3 (≤80 mg/kWh) or class 2 (≤120 mg/kWh) according to EN676 in gas;
- Low NOx class 3 (≤120 mg/kWh) or class 2 (≤185 mg/kWh) according to EN267 in light oil
- **Protection level:** IP 41 (IP 54 and IP 65 on request)



RANGE OVERVIEW

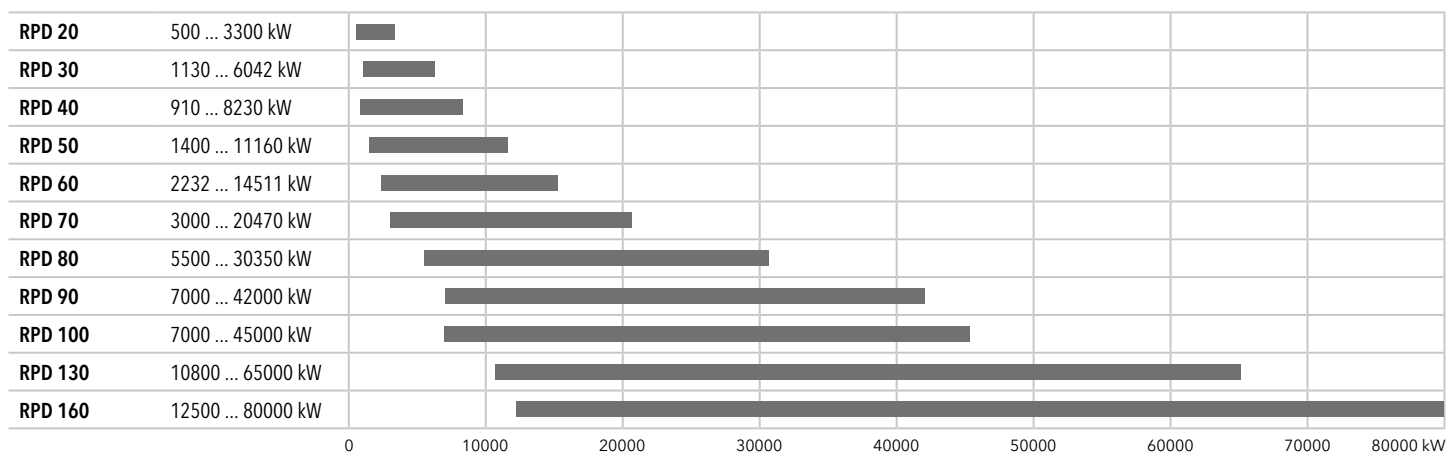

AVAILABLE CONFIGURATIONS

Model	Approx. weight (kg)	Fuel					Operation	
		Gas	Gas/Light oil	Light oil	Heavy oil	Gas/Heavy oil	Mechanical	Electronic
RPD 20	370	●	●	●	●	●	●	●
RPD 30	400	●	●	●	●	●	●	●
RPD 40	430	●	●	●	●	●	●	●
RPD 50	550	●	●	●	●	●	●	●
RPD 60	600	●	●	●	●	●	●	●
RPD 70	760	●	●	●	●	●	●	●
RPD 80	1060	●	●	●	●	●	●	●
RPD 90	1200	●	●	●	●	●	●	●
RPD 100	1250	●	●	●	●	●	●	●
RPD 130	2850	●	●	●	●	●	●	●
RPD 160	3080	●	●	●	●	●	●	●



DIMENSIONS (mm)

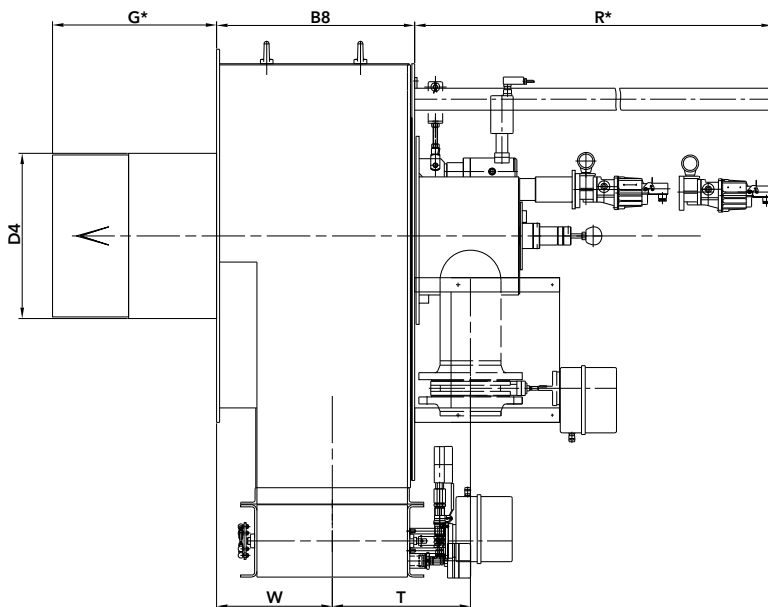
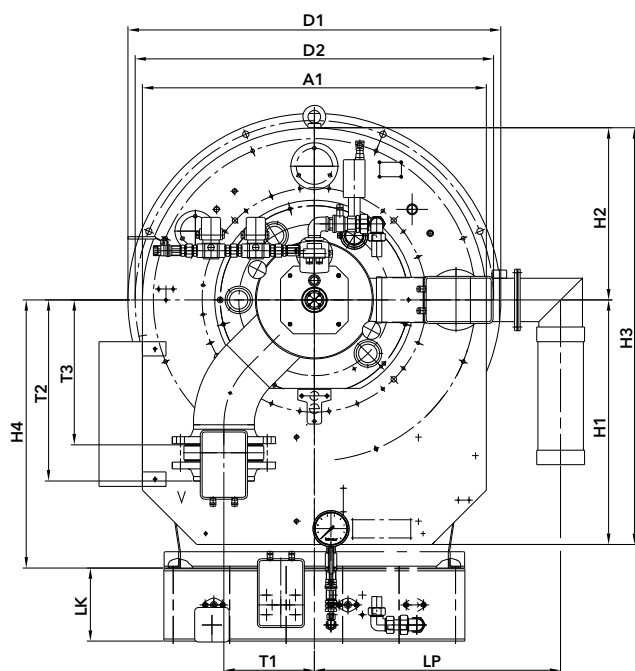

Air connection flange

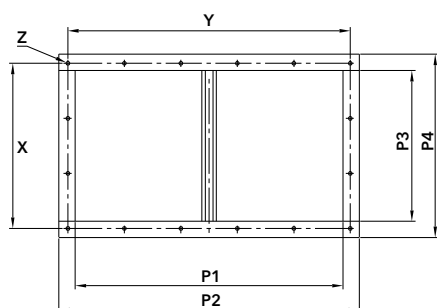

Details of boiler front plate

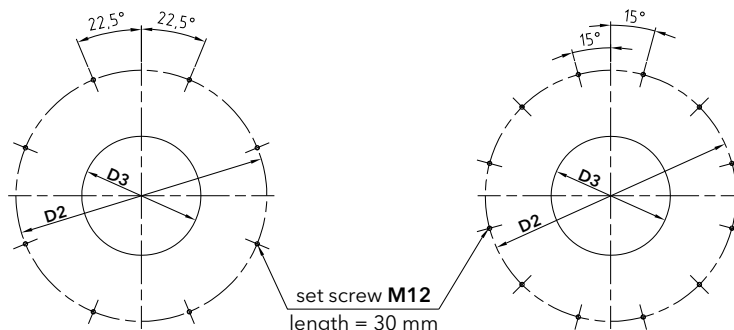

RPD 20 - 60

RPD 70 - 100

Model	A1	B8	D1	D2	D3	D4	D7	H1	H2	H3	H4	P1	P2	P3	P4	T	T1	T2	T3	V	W	X	Y	Z	LK	LP
RPD 20	values dependent on design variant																									
RPD 30	745	428	830	790	385	371	17,5	620	373	993	650	580	670	320	410	342	192	458	362	DN80	248	4x92	5x126	10	202	594
RPD 40	745	428	830	790	423	409	17,5	620	373	993	650	580	670	320	410	342	192	458	362	DN80	248	4x92	5x126	10	202	594
RPD 50	950	547	1030	990	470	456	17,5	675	475	1150	740	740	830	416	506	382	250	500	400	DN150	319	3x152	5x156	10	202	680
RPD 60	994	634	1080	1040	520	506	18	700	497	1197	825	750	840	470	560	439	270	520	420	DN150	379	4x129	5x160	10	202	704
RPD 70	1160	731	1240	1200	640	626	18	780	580	1360	900	936	1026	600	690	501	365	479	479	DN150	410	5x128	7x140	10	202	841
RPD 80	1350	860	1450	1400	740	710	18	820	675	1495	1000	1102	1192	700	790	561	310	647	547	DN150	489	6x125	9x128	10	202	909
RPD 90	1700	890	1800	1750	883	870	18	905	850	1755	1100	1300	1390	742	832	618	310	743	643	DN150	494	6x132	10x135	10	202	1043
RPD 100	1700	890	1800	1750	935	922	18	905	850	1755	1100	1300	1390	742	832	618	310	743	643	DN150	494	6x132	10x135	10	202	1043
RPD 130	values dependent on design variant																									
RPD 160	values dependent on design variant																									

*: value G and R are defined based on the coating of the boiler
 All values are referred to standard burner versions and may vary in base of the configuration chosen

GAS TRAINS

Gas train for EK EVO 6/7 and NEXTRON N6/N7 (EN676 configuration)

DUNGS

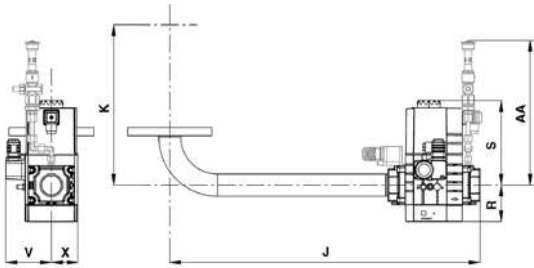

DUNGS basic gas trains delivery scope and description:

- gas compact unit MBC
- minimum gas pressure switch
- fittings between burner and gas train

DUNGS gas trains		
Designation	Type	Code
GT-d452-1"1/2 ⁽¹⁾	Threaded design	3750510
GT-d453-2" ⁽¹⁾	Basic version	3750511
GT-d454-65	Flanged design Basic version	3750512
GT-d455-80		3750513
GT-d456-100		3750514

⁽¹⁾: model with integrated filter

⁽²⁾: in PED configuration

Dimensions	J	K		R	S	V	X	AA ⁽²⁾
		EK6/N6	EK7/N7					
d1"1/2-Rp1"1/2	685	375	405	80	190	100	60	320
d2"-Rp2"	760	405	435	100	330	125	115	385
d65-DN65	795	355	385	185	250	110	100	385
d80-DN80	815	375	405	210	295	155	110	275
d100-DN100	875	375	405	250	330	165	115	275

SIEMENS

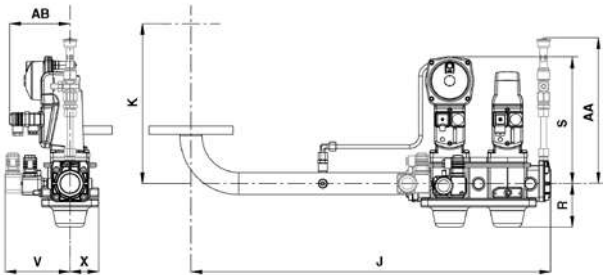

SIEMENS basic gas trains delivery scope and description:

- gas compact unit VGD20/40 including actuators SKP15 and SKP25
- minimum gas pressure switch
- fittings between burner and gas train

SIEMENS gas trains		
Designation	Type	Code
GT-s451-1"1/2	Threaded design	3750525
GT-s452-2"	Basic version	3750526
GT-s453-65	Flanged design Basic version	3750527
GT-s454-80		3750528
GT-s455-100		3750529
GT-s456-125		3750530

⁽²⁾: in PED configuration

Dimensions	J	K		R	S	V		X	AA ⁽²⁾	AB
		EK6/N6	EK7/N7			(2)	(2)			
s1"1/2-Rp1"1/2	795	375	405	100	285	105	145	65	320	135
s2"-Rp2"	805	405	435	105	285	105	145	100	325	140
s65-DN65	795	355	385	120	305	125	125	110	365	135
s80-dN80	815	375	405	135	315	125	125	110	375	135
s100-DN100	855	375	405	145	335	145	145	125	385	135
s125-DN125	905	375	405	180	350	160	160	140	400	135

i Gas trains are fully mounted, electrical connected and tested (electrical, hydraulic, leakage)
Additional components (filter and other options) in order to comply to the local regulation and codes of practise must be ordered separately

FILTERS

Gas filter with flange PN 16, with non-ferrous metal, max. working pressure 2 bar

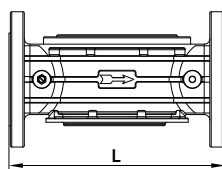

DN40	L = 160 mm	3757196
DN50	L = 160 mm	3757197
DN65	L = 290 mm	3757198
DN80	L = 310 mm	3757201
DN100	L = 350 mm	3757195
DN125	L = 480 mm	3757209
DN150	L = 480 mm	3757210

Gas train for EK EVO 8/9 and NEXTRON N8/N9 (EN676 configuration)

DUNGS

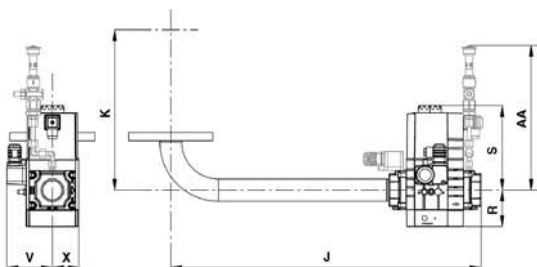

DUNGS basic gas trains delivery scope and description:

- gas compact unit MBC
- minimum gas pressure switch
- fittings between burner and gas train

DUNGS gas trains		
Designation	Type	Code
GT-d457-2" ⁽¹⁾	Threaded design	3750515
GT-d458-65	Flanged design Basic version	3750516
GT-d459-80		3750517
GT-d460-100		3750518

⁽¹⁾: model with integrated filter
⁽²⁾: in PED configuration

Dimensions	J	K		R	S	V	X	AA ⁽²⁾
		EK8/N8	EK9/N9					
d2"-Rp2"	760	598	623	100	330	125	115	385
d65-DN65	795	598	623	185	250	110	100	385
d80-DN80	815	598	623	210	295	155	110	275
d100-DN100	875	598	623	250	330	165	115	275

SIEMENS

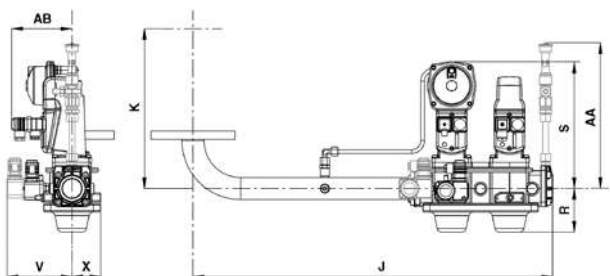

SIEMENS basic gas trains delivery scope and description:

- gas compact unit VGD20/40 including actuators SKP15 and SKP25
- minimum gas pressure switch
- fittings between burner and gas train

SIEMENS gas trains		
Designation	Type	Code
GT-s457-2"	Threaded design	3750537
GT-s458-65	Flanged design Basic version	3750538
GT-s459-80		3750539
GT-s460-100		3750540
GT-s461-125		3750541

⁽²⁾: in PED configuration

Dimensions	J	K		R	S	V		X	AA ⁽²⁾	AB
		EK8/N8	EK9/N9			(2)	(2)			
s2"-Rp2"	805	598	623	105	285	105	145	100	325	135
s65-DN65	795	598	623	120	305	125	125	110	365	135
s80-dN80	815	598	623	135	315	125	125	110	375	135
s100-DN100	855	598	623	145	335	145	145	125	385	135
s125-DN125	905	598	623	180	350	160	160	140	400	135

i Gas trains are fully mounted, electrical connected and tested (electrical, hydraulic, leakage)
 Additional components (filter and other options) in order to comply to the local regulation and codes of practise must be ordered separately

FILTERS

Gas filter with flange PN 16, with non-ferrous metal, max. working pressure 2 bar

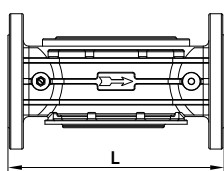

DN40	L = 160 mm	3757196
DN50	L = 160 mm	3757197
DN65	L = 290 mm	3757198
DN80	L = 310 mm	3757201
DN100	L = 350 mm	3757195
DN125	L = 480 mm	3757209
DN150	L = 480 mm	3757210

GAS TRAINS

Gas train for N10 (EN676 configuration)

DUNGS

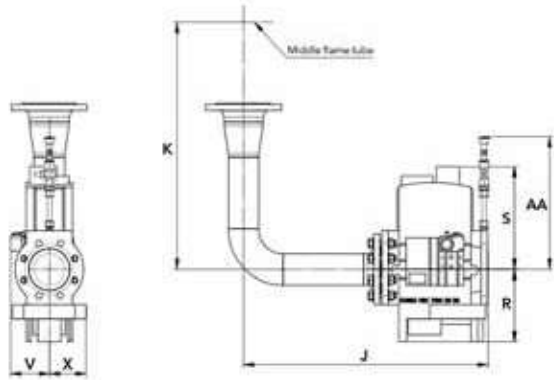

DUNGS basic gas trains delivery scope and description:

- gas compact unit MBC
- minimum gas pressure switch
- connecting piece between burner and gas train

i Other configurations: available on request

DUNGS gas trains		
Designation	Type	Code
d80	Flanged design Basic version	on request
d100		on request
d125		on request

⁽¹⁾: in PED configuration

Dimensions	J	K	R	S	V	X	AA ⁽¹⁾
d80	710	912	205	292	113	107	376
d100	754	912	250	329	124	125	395
d125	800	912	250	415	137	125	395

SIEMENS

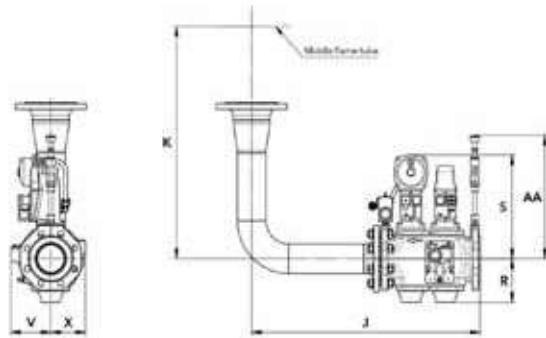

SIEMENS basic gas trains delivery scope and description:

- gas compact unit VGD20/40 including actuators SKP15 and SKP25
- minimum gas pressure switch
- connecting piece between burner and gas train

i Other configurations: available on request

SIEMENS gas trains		
Designation	Type	Code
s80	Basic configuration valve + connection pipe	3757394
s100		3757395
s125		3757396
s150		3757397

⁽¹⁾: in PED configuration

Dimensions	J	K	R	S	V	X	AA ⁽¹⁾
s80	710	912	132	312	125	108	372
s100	750	912	145	335	141	124	356
s125	800	912	175	348	155	138	392
s150	880	912	188	365	176	159	409

i Gas trains are fully mounted, electrical connected and tested (electrical, hydraulic, leakage)
Additional components (filter and other options) in order to comply to the local regulation and codes of practise must be ordered separately

FILTERS

Gas filter with flange PN 16, with non-ferrous metal, max. working pressure 2 bar	DN80	L = 310 mm	3757201
	DN100	L = 350 mm	3757195
	DN125	L = 480 mm	3757209
	DN150	L = 480 mm	3757210

Gas train for N11 (EN676 configuration)

DUNGS

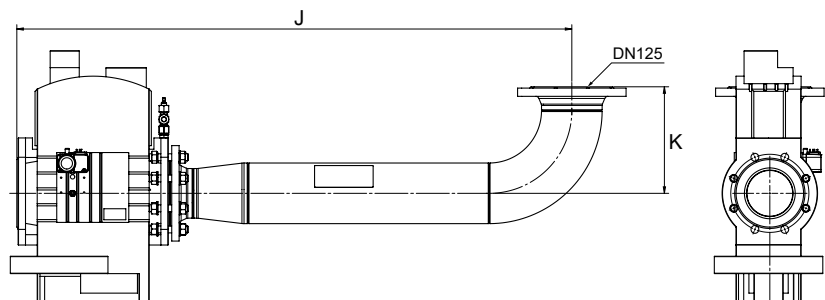

DUNGS basic gas trains description:

- gas train in standard configuration is mounted on the left side
- a support for the gas train is required additionally (code 3752216, see page 220)

i Other configurations: available on request

DUNGS gas trains		
Designation	Type	Code
d100	Flanged design	3758179
d125	Basic version	3758180

Dimensions	J	K
d100	1279	245,5
d125	1330	245,5

SIEMENS

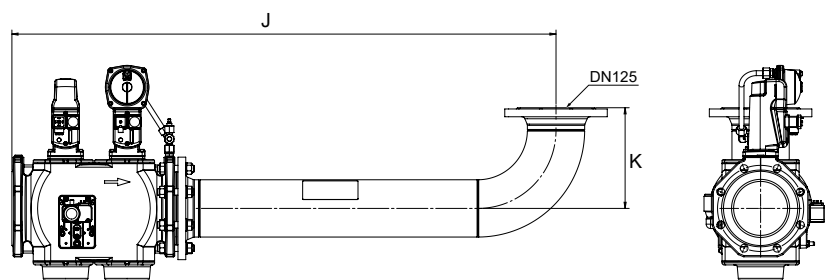

SIEMENS basic gas trains description:

- gas train in standard configuration is mounted on the left side
- a support for the gas train is required additionally (code 3752216, see page 220)

i Other configurations: available on request

SIEMENS gas trains		
Designation	Type	Code
s100	Basic configuration valve + connection pipe	3758176
s125		3758177
s150		3758178

Dimensions	J	K
s100	1277	245,5
s125	1327	245,5
s150	1407	245,5

i Gas trains are fully mounted, electrical connected and tested (electrical, hydraulic, leakage) Additional components (filter and other options) in order to comply to the local regulation and codes of practise must be ordered separately

FILTERS

Gas filter with flange PN 16, with non-ferrous metal, max. working pressure 2 bar	DN80	L = 310 mm	3757201
	DN100	L = 350 mm	3757195
	DN125	L = 480 mm	3757209
	DN150	L = 480 mm	3757210

GAS TRAINS

Gas train for GHO-TRON (EN676 configuration)

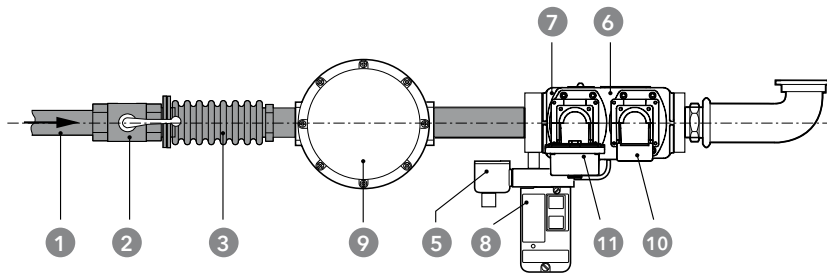

1. main gas pipe
2. ball valve*
3. anti-vibration coupling*
5. minimum gas pressure switch
6. safety gas valve
7. main gas valve
8. leakage control device*
9. gas filter* (governor included in the valve)
10. actuator SKP 15
11. actuator SKP 75

*: additional components to be ordered separately, e.g.: maximum gas pressure switch and other gas options in order to comply to the local regulation and codes of practise

Designation	Description	Code
GT-2"	VGD20.503	on request
GT-DN65	VGD40.065	on request
GT-DN80	VGD40.080	on request
GT-DN100	VGD40.100	on request
GT-DN125	VGD40.125	on request

GHO-TRON configuration:

gas ignition unit is included in the body of the burner, the price is included in the burner price.

i Gas trains are fully mounted, electrical connected and tested (electrical, hydraulic, leakage)
Additional components (filter and other options) in order to comply to the local regulation and codes of practise must be ordered separately

FILTERS

2"	on request
DN65 - 2"1/2	on request
DN80 - 3"	on request
DN100 - 4"	on request
DN125 - 5"	on request

GAS TRAIN CONNECTION PIPE

GTCP RP50 platform 2-3-4	GHO-TRON 2-3-4 with GT-2"	on request
GTCP reducer from DN80 to DN65 platform 2-3-4	GHO-TRON 2-3-4 with GT-DN65	on request
GTCP reducer from DN100 to DN80 platform 4-5	GHO-TRON 4-5 with GT-DN100	on request
GTCP reducer from DN125 to DN80 platform 5	GHO-TRON 5 with GT-DN125	on request

BT3

The device is composed of a control box for safety and for programming the parameters of mono- and dual fuel burners with intermittent or continuous operation through a step by step servomotor up to 10 Nm.

The BT300 combines the benefits of an electronic fuel-air ratio control system with up to three motorised actuating devices and an optional modules like an analogue output for speed control of the combustion air fan with an electronic burner control unit.

The device is equippable with the following modules:

- fan speed regulation;
- burner power regulation;
- control of combustion air excess;
- CO control (through simple or combined probe);
- communication via Bus system.

The BT300 is available in three designs with the following specific functions:

- **BT320** for single fuel burner and intermittent operation, with an output 0...10 V, 0/4...20 mA and the management of two servomotors;
- **BT330** for single fuel burner and continuous operation, using suitable flame detectors, with an output 0...10 V, 0/4...20 mA and the management of three servomotors;
- **BT340** for dual fuel burner and continuous operation, using suitable flame detectors, with an output 0...10 V, 0/4...20 mA and the management of three servomotors.

Main characteristics of the control box:

- power supply: 230 V -15...+10%, 50 Hz;
- servomotors from 1,2 to 10 Nm.

COMMUNICATION MODULE

BT300 module for electronic burners mounted in the switch cabinet of the burner (Note: one LCM module is required)	ModBus/BT3	3754081
	ProfiBus/BT3	3750142
	Ethernet/BT3	on request

LCM MODULE

Module required for O ₂ control, Variatron and communication buses connections	3752286
---	----------------

Note: only one LCM module is necessary for these 3 options; the module is already included on dual fuel burners

REMOTE SOFTWARE

Kit to connect a PC laptop to the BT300 for its parametrization	LSA100 + USB/CAN + CD-Rom	3751130
---	---------------------------	----------------

ETAMATIC AND ETAMATIC OEM

The Etamatic control units are available on request according to the configuration of the burner selected.

Electronic control **Etamatic** with 4 DPS-adjusting outputs for servodrives up to 50 mA of direct current with:

- incorporated tightness control of the valves;
- incorporated regulator of power;
- incorporated counter of working hours with pulse transducer;
- incorporated relay of flame;
- incorporated program of O₂ regulation, including the system Lamtec with connecting bus.

Electronic control **Etamatic S** with a steady adjusting output for the regulation of the number of revolutions of the fan supplying the air of burning and 4 DPS-adjusting outputs for the servodrives up to 50 mA of direct current with:

- incorporated tightness control of the valves;
- incorporated regulator of power;
- incorporated counter of working hours with pulse transducer;
- incorporated relay of flame;
- incorporated program of O₂ regulation, including the system Lamtec with connecting bus.

For the control of the number of revolutions it is required additionally:

- Static frequency converter;
- Switch Namur.

INTERFACE MODULES FOR ETAMATIC AND ETAMATIC OEM

Profibus module for ETA+OEM with 2 m cable	3752995
Modbus module RTU RS232 for ETA+OEM with 2m cable	3752467
Modbus module RTU RS422/484 for ETA+OEM with 2m cable	3756474
Ethernet module TCP/IP for ETA+OEM with 2m cable	3757955

ACCESSORIES FOR ETAMATIC OEM

Software for remote PC connection for Lamtec ETAMATIC OEM with all its accessories for the connection (available languages: English, German and French)	3753366
Customer interface (DISPLAY) for ETAMATIC OEM	3751683
Hand held programming unit for ETAMATIC OEM (languages: German and English) - Alternative to software 3753366 when PC is not available	1718850339
Hand held programming unit for ETAMATIC OEM (language: Russian) - Alternative to software 3753366 when PC is not available	3754519

Note: either customer interface or operation and display unit has to be included

O₂ TRIM FOR BT300, ETAMATIC AND ETAMATIC OEM

This device optimizes the combustion in order to keep the air excess as much stable as possible irrespective of the changings that can occur during operations, for instance slight calorific value variations, combustion air temperature and pressure. This improves the seasonal efficiency and therefore reduces the fuel consumption.

The kit includes all the fittings for the installation. Main components are:

- control unit with display;
- probe;
- intake pipe to be fixed to the stack (choose the proper length).

The control unit has to be installed close to the probe (max 20 m of cable)

The probe needs a calibration but no reference gas is necessary.

The display shows the O₂ content.

Maximum distance between the control unit and the burner control panel is 500 m.

	Output	Probe length	Code
Kit for O₂ trim (LT3 + LS2) - Flue temp max 300 °C - display for O₂ visualization (Note: for models equipped with BT3xx this kit needs a LCM module installed in the burner control panel)	1 x 4-20 mA	150 mm	3757433
	1 x 4-20 mA	300 mm	3757137
	1 x 4-20 mA	450 mm	3757138

O₂ TRIM WITH CO MEASURE FOR BT300, ETAMATIC AND ETAMATIC OEM

This device optimizes the combustion in order to keep the air excess as low as possible in order to maximize the seasonal efficiency and therefore minimize the fuel consumption.

In addition to the features of the O₂ trim only, this kit reduces the air excess to its minimum because this system continuously measures the CO content in the flue: should the air excess be reduced too much, the CO raises and the system reacts by increasing the air excess in order to keep firing in safe conditions.

The kit includes all the fittings for the installation. Main components are:

- control unit with display;
- probe;
- intake pipe to be fixed to the stack (choose the proper length).

The control unit has to be installed close to the probe (max 20 m of cable).

The probe needs a calibration but no reference gas is necessary.

The display shows the O₂ content.

Maximum distance between the control unit and the burner control panel is 500 m.

Note: this system is not suitable for GL-EUF and L-EUF burners

	Output	Probe length	Code
Kit for O₂ trim and CO control (LT3-F + KS1D) - Flue temp max 300 °C (Note: for models equipped with BT3xx this kit needs a LCM module installed in the burner control panel)	None	150 mm	3758001
	None	300 mm	3755046
	None	450 mm	3756533
	4 x 0/4-20mA	300 mm	3754549
	4 x 0/4-20mA	450 mm	3754550
	4 x 0/4-20mA & 4 x digital	300 mm	3754551
	4 x 0/4-20mA & 4 x digital	450 mm	3754552

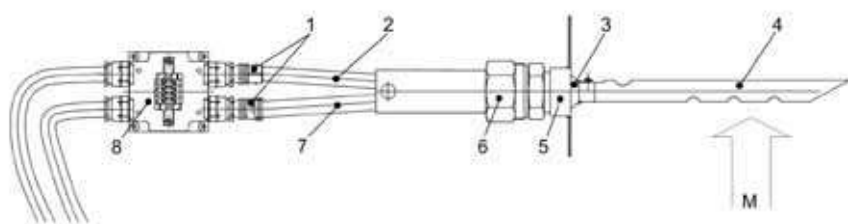

- M - measuring gas 300°C max
- 1 - plug
- 2 - probe signal
- 3 - Lambda Probe
- 4 - gas extraction device (GED)
- 5 - half-collar R1 1/4
- 6 - probe installation fitting (PIF)
- 7 - probe heater
- 8 - probe connection box (PCB)

FREQUENCY CONVERTER ABB FOR EXTERNAL INSTALLATION

IP21 with: <ul style="list-style-type: none"> • EMC filter • Inductor • Control panel 	3 kW	3757054
	4 kW	3757055
	5,5 kW	3757056
	7,5 kW	3757057
	11 kW	3757058
	15 kW	3757059
	18,5 kW	3757060
	22 kW	3757061
	30 kW	3757062
	37 kW	3757063
	45 kW	3757064
	55 kW	3757065
	75 kW	3757066
IP55 with: <ul style="list-style-type: none"> • EMC filter • Inductor • Control panel 	3 kW	3757067
	4 kW	3757068
	5,5 kW	3757069
	7,5 kW	3757070
	11 kW	3757071
	15 kW	3757072
	18,5 kW	3757073
	22 kW	3757074
	30 kW	3757075
	37 kW	3757076
	45 kW	3757077
	55 kW	3757078
	75 kW	3757079

ACOUSTIC SHROUDS FOR EK EVO AND N10

Product description:

- sound level reduction (sound pressure level): ca. 20 ... 30 dB(A)
- sheet metal casing, structured coating, isolation with temperature resistant mineral wool
- noise absorption material acc. DIN 4102, covered with a glass fibre layer, covered with perforated sheet metal, galvanised
- easily disassembled into elements: base plate, side covers, top cover, air inlet section
- all elements easily connected via quick locks
- height of noise reduction casing adjustable on wheels
- feed through for gas-, oil- and electrical connections integrated in side covers following the requirements
- air inlet via noise reduction line
- if required, an oil recuperation tub can be integrated on the base plate
- for some boiler types a supporting frame for the casing may be necessary, due to the height of the burner tube over the floor

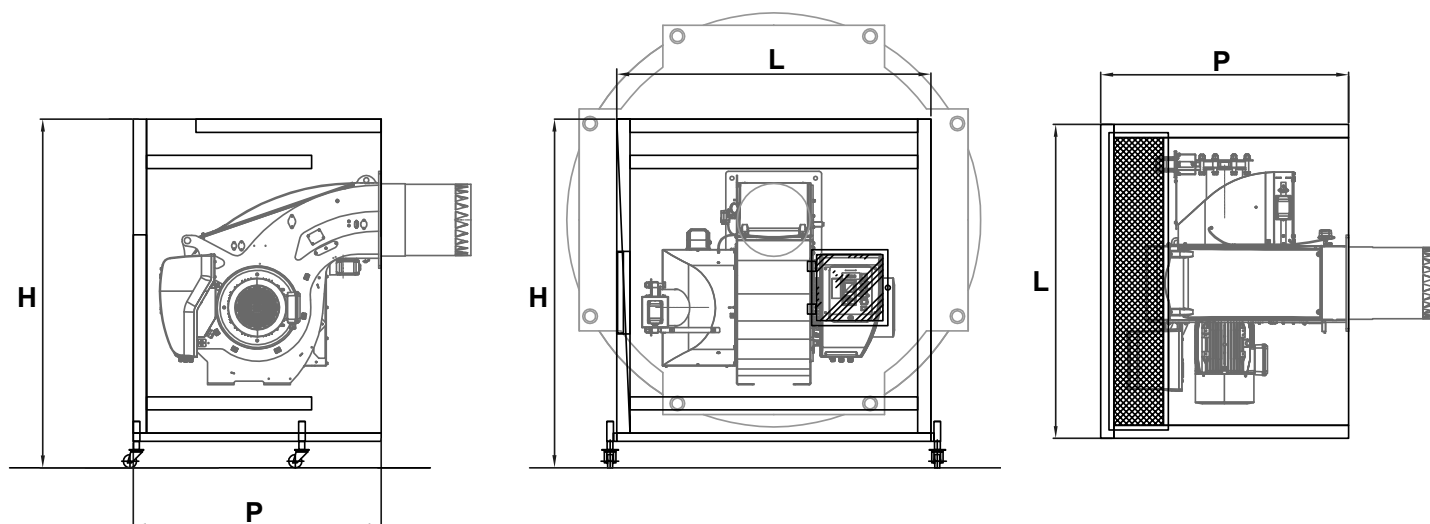

MODELS FOR EK EVO

Designation	L (mm)	P (mm)	H (mm)	Weight (kg)	Code
EKEVO 6.2400/2900 G-...	1450	1350	1200	200	3757453
EKEVO 7.3600/4500 G-...	1550	1400	1300	246	3757455
EKEVO 7.5800 G-...	1570	1850	1300	246	3757457
EKEVO 8.5800/7100 G-...	1760	1630	1580	325	3757458
EKEVO 9.8700/10400 G-...	1750	1630	1750	368	3757460
EKEVO 9.13000 G-...	1850	1750	1750	396	3757462
EKEVO 6.2400/2900 GL-.../L-...	1450	1350	1200	200	3757454
EKEVO 7.3600/4500 GL-.../L-...	1450	1350	1400	256	3757456
EKEVO 8.5800/7100 GL-.../L-...	1760	1630	1580	335	3757459
EKEVO 9.6500...10400 GL-.../L-...	1760	1630	1750	378	3757461

MODELS FOR N10

Designation	L (mm)	P (mm)	H (mm)	Weight (kg)	Code
N10 G-...	1900	1780	1900	478	3757463
N10 GL-...	1900	1780	1900	488	3757464
N10 L-...	1900	1780	1900	488	3757464

NOTE: Before submitting your order please provide information on the boiler model and the type of installation: floor standing boiler or boiler mounted on a base.

BALL VALVE

	Female threaded ball valve, max. working gas pressure: 1 bar	FRp1/2"	3751028
		FRp3/4"	3751029
		FRp1"	3751030
		FRp1"1/2	3751031
		FRp2"	3751032
	Flanged ball valve, max. working gas pressure: 16 bar	DN40	3751033
		DN50	3751034
		DN65	3751035
		DN80	3751036
		DN100	3751037
		DN125r	3751038
		DN150	3751039

ANTI-VIBRATION COUPLING (COMPENSATOR)

	Male-threaded anti-vibration coupling	MRp1"	3751018
		MRp1"1/2	3751019
		MRp2"	3751020
	Flanged anti-vibration coupling, max. working gas pressure: 10 bar	DN40	3751021
		DN50	3751022
		DN65	3751023
		DN80	3751024
		DN100	3751025
		DN125	3751026
		DN150	3751027

GAS FILTER

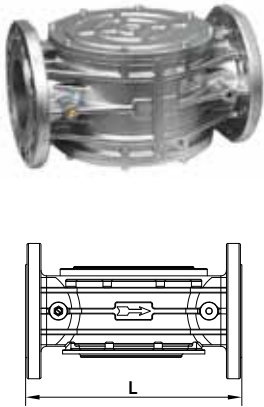
	Filter with non-ferrous metal, max. working pressure: 2 bar	Rp1"1/2	L = 160 mm	3757199
		Rp2"	L = 160 mm	3757200
	Filter with flange PN16, non-ferrous metal, max. working pressure: 2 bar	DN40	L = 230 mm	3757196
		DN50	L = 230 mm	3757197
		DN65	L = 290 mm	3757198
		DN80	L = 310 mm	3757201
		DN100	L = 350 mm	3757195
		DN125	L = 480 mm	3757209
		DN150	L = 480 mm	3757210
	Filter with flange PN16, non-ferrous metal, max. working pressure: 6 bar	DN40	L = 230 mm	3757205
		DN50	L = 230 mm	3757206
		DN65	L = 290 mm	3757207
		DN80	L = 310 mm	3757208
		DN100	L = 350 mm	3757202
		DN125	L = 480 mm	3757203
		DN150	L = 480 mm	3757204

PRESSURE REGULATOR

<p>Gas pressure regulator GDJ Max. working pressure 0,4 bar, non-ferrous metal</p> 	GDJ Rp1/2" x 100 mm	with spring 16 ... 28 mbar	3333123399
		spring for 10 ... 20 mbar	1478682742
		spring for 22 ... 40 mbar	1478781122
		spring for 40 ... 55 mbar	12001218
	GDJ Rp3/4" x 125 mm	with spring 12,5 ... 25 mbar	3333123400
		spring for 22,5 ... 35 mbar	3753834
		spring for 30 ... 50 mbar	3753835
	GDJ Rp1" x 125 mm	with spring 12,5 ... 25 mbar	3333123401
		spring for 22,5 ... 35 mbar	3753834
		spring for 30 ... 50 mbar	3753835
	GDJ Rp1 1/2 x 155 mm	with spring 12,5 ... 25 mbar	3333123402
		spring for 22,5 ... 35 mbar	3753840
		spring for 30 ... 50 mbar	3753841
	GDJ Rp2" x 200 mm	with spring 12,5 ... 25 mbar	3333123403
		spring for 22,5 ... 35 mbar	3753847
		spring for 30 ... 50 mbar	3753848
<p>Gas pressure regulator FRS Max. working pressure 0,4 bar, non-ferrous metal</p> 	FRS s40-DN40 x 200 mm	with spring 10 ... 30 mbar	1478490702
		red spring for 25 ... 55 mbar	1478435327
		yellow spring for 30 ... 70 mbar	1478435338
		black spring for 60 ... 110 mbar	1478435349
	FRS s50-DN50 x 230 mm	with spring 10 ... 30 mbar	1478490713
		red spring for 25 ... 55 mbar	1478435372
		yellow spring for 30 ... 70 mbar	1478435383
		black spring for 60 ... 110 mbar	1478435394
	FRS s65-DN65 x 290 mm	with spring 10 ... 30 mbar	1478490724
		red spring for 25 ... 55 mbar	1478435429
		yellow spring for 30 ... 70 mbar	1478435430
		black spring for 60 ... 110 mbar	1478435441
		pink spring for 100 ... 150 mbar	1478494328
	FRS s80-DN80 x 310 mm	with spring 10 ... 30 mbar	3750211
		red spring for 25 ... 55 mbar	1478435429
		yellow spring for 30 ... 70 mbar	1478435430
		black spring for 60 ... 110 mbar	1478435441
		pink spring for 100 ... 150 mbar	1478494328
	FRS s100-DN100 x 350 mm	with spring 10 ... 30 mbar	12001097
		red spring for 25 ... 55 mbar	1478435474
		yellow spring for 30 ... 70 mbar	1478435485
		black spring for 60 ... 110 mbar	1478435496
		pink spring for 100 ... 150 mbar	1478781519
	FRS s125-DN125 x 400 mm	with spring 10 ... 30 mbar	12001098
red spring for 25 ... 55 mbar		1478434982	
yellow spring for 30 ... 70 mbar		1478434993	
black spring for 60 ... 110 mbar		1478435009	
pink spring for 100 ... 150 mbar		1478740474	
FRS s150-DN150 x 480 mm	with spring 10 ... 30 mbar	12001099	
	red spring for 25 ... 55 mbar	1478435032	
	yellow spring for 30 ... 70 mbar	1478435043	
	black spring for 60 ... 110 mbar	1478435054	
	pink spring for 100 ... 150 mbar	1478781484	

PRESSURE REGULATOR

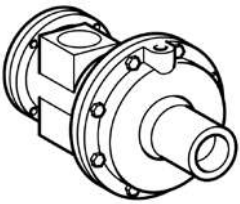
Gas pressure regulator RS 250	with safety valve and flange PN16, max. working pressure 6 bar	RS250 DN25 x 230 mm	1478541586
		RS250 DN50 x 230 mm	1478541597
		RS250 DN80 x 310 mm	1478541600
		RS250 DN100 x 350 mm	1478541611
		RS250 DN150 x 480 mm	1478541622
Gas pressure regulator RS 251	with safety valve and flange PN16, max. working pressure 4 bar	RS251 DN50 x 310 mm	1478548747
		RS251 DN80 x 410 mm	1478548758
Safety blow-off valve S10 	with internal thread Rp1", max. working pressure 1 bar	discharge pressure 80 mbar	1478687054
		discharge pressure 100 mbar	1478687065
		discharge pressure 120 mbar	1478687076
		discharge pressure 140 mbar	1478687087
		discharge pressure 160 mbar	1478687098
		discharge pressure 180 mbar	1478687101
		discharge pressure 200 mbar	1478687112
		discharge pressure 220 mbar	1478687123
		discharge pressure 240 mbar	1478687134
		discharge pressure 260 mbar	1478687145
		discharge pressure 280 mbar	1478687156
		discharge pressure 300 mbar	1478687167

GAS PRESSURE SWITCH

	For installation on double electromagnetic valves, max. working pressure 0,5 bar	GW50A5	3751554
		GW150A5	3751555
		GW500A5	3752190
	For installation on electromagnetic/motorized valves, max. working pressure 0,5 bar	GW50A6	3752189
		GW150A6	3751556
		GW500A6	3751557

MANOMETER

	Gas manometers with push-button valve, Rp1/2"	0 - 60 mbar	3751627
		0 - 100 mbar	3751546
		0 - 160 mbar	3751550
		0 - 250 mbar	3751551
		0 - 600 mbar	3751552
		0 - 1,6 bar	3751545
		0 - 6 bar	3751544

TEST BURNER

Test burner with push-button valve, Rp1/2"	max pressure 0,5 bar	3751553
---	----------------------	----------------

INSERT RING

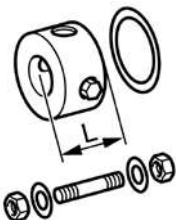
	Insert ring with connections Rp1/2" and Rp3/4" for manometer and test burner	DN40	L = 50 mm	3752194
		DN50	L = 50 mm	3752195
		DN65	L = 50 mm	3752196
		DN80	L = 50 mm	3752197
		DN100	L = 50 mm	3752198
		DN125	L = 50 mm	3752199
		DN150	L = 50 mm	3752200

FLOW COUNTER

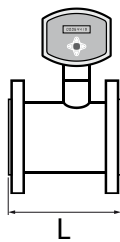
	TME 400-VM without 4-20mA output	DN50 - PN10	100 m³/h	L = 150 mm	3757525
		DN80 - PN10	250 m³/h	L = 120 mm	3757526
		DN80 - PN10	400 m³/h	L = 120 mm	3757527
		DN100 - PN10	400 m³/h	L = 150 mm	3757528
		DN100 - PN10	650 m³/h	L = 150 mm	3757529
		DN150 - PN10	1000 m³/h	L = 175 mm	3757530
		DN150 - PN10	1600 m³/h	L = 175 mm	3757531
		DN200 - PN16	1600 m³/h	L = 200 mm	3757532
		DN200 - PN16	2500 m³/h	L = 200 mm	3757533
	TME 400-VM-A with 4-20mA output	DN50 - PN10	100 m³/h	L = 150 mm	3757534
		DN80 - PN10	250 m³/h	L = 120 mm	3757535
		DN80 - PN10	400 m³/h	L = 120 mm	3757536
		DN100 - PN10	400 m³/h	L = 150 mm	3757537
		DN100 - PN10	650 m³/h	L = 150 mm	3757538
		DN150 - PN10	1000 m³/h	L = 175 mm	3757539
		DN150 - PN10	1600 m³/h	L = 175 mm	3757540
		DN200 - PN16	1600 m³/h	L = 200 mm	3757541
		DN200 - PN16	2500 m³/h	L = 200 mm	3757542

FLEXIBLE HOSE

	Stainless steel, max pressure 4 bar	Rp1/2"	L = 500 mm	4488681772
		Rp1/2"	L = 1000 mm	4488681783
		Rp3/4"	L = 500 mm	4488681794
		Rp3/4"	L = 1000 mm	4488682708
		Rp1"	L = 500 mm	4488682719
		Rp1"	L = 1000 mm	4488682720
	Stainless steel, max pressure 1 bar	Rp3/8"-Rp1/2"	L = 500 mm	4488696511
		Rp3/8"-Rp1/2"	L = 1000 mm	4488696522
		d2"-Rp2"	L = 500 mm	4488696533
		d2"-Rp2"	L = 1000 mm	4488696544

HOLDER

	<p>Holder for gas train</p>	<p>For gas train DN40...DN150 Support height: x = 545...935 mm</p>	<p>3752216</p>
---	------------------------------------	--	-----------------------

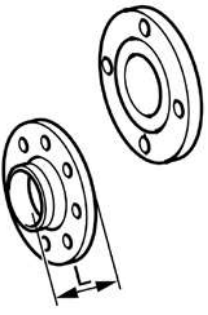

FLANGES

	<p>Threaded flange PN16</p>	<p>Rp3/4"</p>	<p>3333109195</p>
		<p>1"</p>	<p>3333109196</p>
		<p>Rp1"1/2</p>	<p>3333109197</p>
		<p>Rp2"</p>	<p>3333109198</p>
	<p>Welded flange PN16</p>	<p>DN40 x 42 mm</p>	<p>5318353048</p>
		<p>DN50 x 45 mm</p>	<p>5318428082</p>
		<p>DN65 x 45 mm</p>	<p>5318428093</p>
		<p>DN80 x 50 mm</p>	<p>5318428106</p>
		<p>DN100 x 52 mm</p>	<p>5318428117</p>
		<p>DN125 x 55 mm</p>	<p>5318428128</p>
		<p>DN150 x 55 mm</p>	<p>5318428139</p>

STRAIGHT PIPE

	<p>Flanged, PN16</p>	<p>DN40 x 500 mm</p>	<p>3752235</p>
		<p>DN50 x 250 mm</p>	<p>3752236</p>
		<p>DN50 x 500 mm</p>	<p>3752237</p>
		<p>DN65 x 250 mm</p>	<p>3752238</p>
		<p>DN65 x 500 mm</p>	<p>3752239</p>
		<p>DN80 x 250 mm</p>	<p>13019834</p>
		<p>DN80 x 500 mm</p>	<p>1688421230</p>
		<p>DN100 x 250 mm</p>	<p>3752240</p>
		<p>DN100 x 500 mm</p>	<p>1688421252</p>
		<p>DN125 x 250 mm</p>	<p>1688421525</p>
		<p>DN125 x 500 mm</p>	<p>1688421274</p>
		<p>DN150 x 250 mm</p>	<p>1688421536</p>
		<p>DN150 x 500 mm</p>	<p>1688421296</p>
		<p>Adapting, flanged PN16</p>	<p>DN25 - DN40 x 144 mm</p>
	<p>DN25 - DN50 x 159 mm</p>		<p>1688586714</p>
	<p>DN25 - DN65 x 173 mm</p>		<p>1688590469</p>
	<p>DN25 - DN80 x 254 mm</p>		<p>1688653209</p>
	<p>DN40 - DN50 x 163 mm</p>		<p>3752223</p>
	<p>DN40 - DN65 x 177 mm</p>		<p>3752224</p>
	<p>DN40 - DN80 x 182 mm</p>		<p>3752226</p>
	<p>DN50 - DN65 x 180 mm</p>		<p>3752225</p>
	<p>DN50 - DN80 x 185 mm</p>		<p>3752227</p>
	<p>DN50 - DN100 x 197 mm</p>		<p>1688590458</p>
	<p>DN65 - DN80 x 197 mm</p>		<p>1688421401</p>
	<p>DN65 - DN100 x 197 mm</p>		<p>1688421412</p>
	<p>DN80 - DN100 x 202 mm</p>		<p>1688421423</p>
	<p>DN80 - DN125 x 232 mm</p>		<p>1688421434</p>
	<p>DN80 - DN150 x 245 mm</p>		<p>1688602591</p>
	<p>DN100 - DN125 x 234 mm</p>		<p>1688421445</p>
	<p>DN100 - DN150 x 247 mm</p>	<p>1688421456</p>	
<p>DN125 - DN150 x 250 mm</p>	<p>1688421467</p>		

ELBOW PIPE

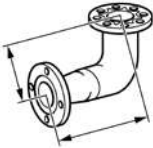
Angle 	90°, male/female	Rp3/4"	3333109257
		Rp1"	3333103790
		Rp1"1/4	3333116894
		Rp1"1/2	3333103791
		Rp2"	3333103792
	90°, female/female	Rp1"	3333109311
Elbow 	PN16, connection Rp1/2"	DN40 x 99 mm	3752182
		DN50 x 121 mm	3752183
		DN65 x 140 mm	3752184
		DN80 x 164,5 mm	3752185
		DN100 x 204,5 mm	1688421354
		DN125 x 245,5 mm	1688421365
		DN125 x 283,5 mm	1688421376
Connection piece 	90°, flanged PN16	DN65 - DN40 x 235 mm	1688551557
		DN65 - DN50 x 235 mm	1688551568
		DN80 - DN40 x 246,5 mm	1688421092
		DN80 - DN50 x 249,5 mm	1688421105
		DN80 - DN65 x 249,5 mm	1688421116
		DN80 - DN80 x 264,5 mm	1688421127
		DN80 - DN100 x 266,5 mm	1688590481
		DN100 - DN65 x 297,5 mm	3755875
		DN100 - DN80 x 302,5 mm	1688551615
		DN150 - DN65 x 503,5 mm	1688666166
		DN150 - DN80 x 418,5 mm	1688421138
		DN150 - DN100 x 420,5 mm	1688421149
		DN150 - DN125 x 423,5 mm	1688421150
		DN150 - DN150 x 423,5 mm	1688421161

GAS PIPE

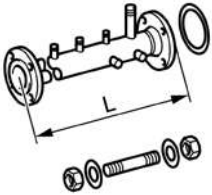
Connections	h3/8"-Rp1/2"x300 mm with two connections 1/2" and one connection 1/4" for DMV SE 512	3333212374	
	d2"-Rp2"x300 mm with two connections 1/2" and one connection 1/4" for DMV SE 520	3333212375	
	Connections for test burner, pressure switch, pressure valve, pressure release valve, ignition valve, safety valve	DN40 x 900 mm	14030405
		DN50 x 900 mm	14030449
		DN65 x 950 mm	code on request
		DN80 x 1100 mm	14030504
		DN100 x 1300 mm	14030537
		DN125 x 1550 mm	code on request
		DN150 x 1800 mm	14030570

SEALS AND CONNECTING KIT

	Screwing set: 1 seal, 4 bolts, 4 nuts, 4 washers	DN25	3751547
		DN40	3751040
		DN50	3751041
		DN65	3751042
		DN80	3751043
		DN100	3751044
		DN125	3751045
		DN150	3751046

VALVES GROUP, TYPE LBA...A

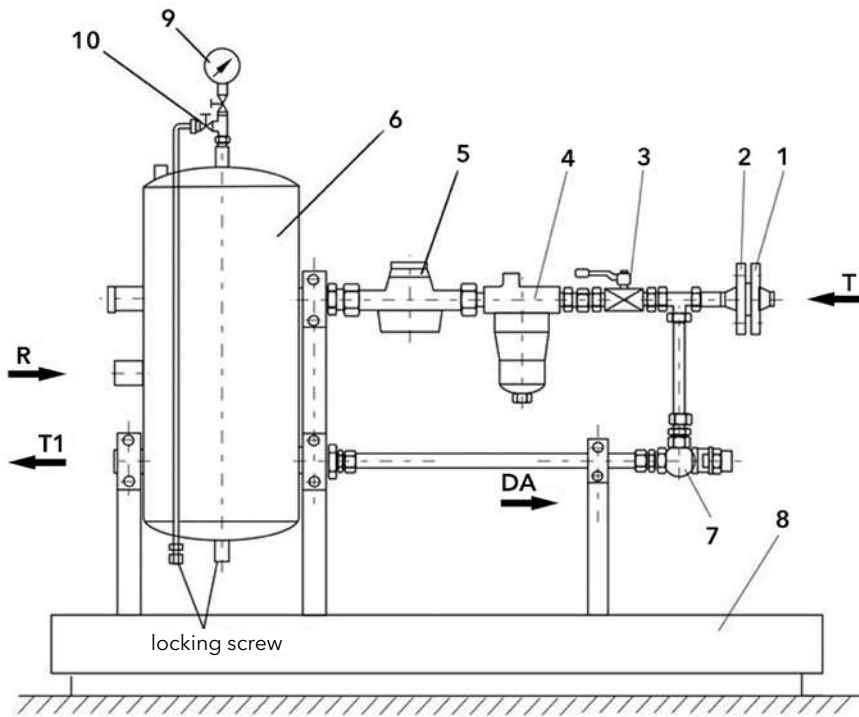

Base equipment

1. Welded flange PN16
2. Connecting flange PN16
3. Ball valve PN16
4. Fuel filter
5. Fuel rate counter with roller counter
6. Pressure tank
7. Relief valve
8. Fuel collector with holding
9. Glycerol manometer 0...10 bar
10. Air valve

		LBA 600 A	LBA 1200 A	LBA 2400 A	LBA 3000 A
Burner pump capacity	l/h	600	1200	2400	3000
Fuel rate for burner capacity "T"	l/h	10 ... 200	10 ... 400	30 ... 1000	75 ... 2000
Flange connection "T" on feed line	PN16	DN15	DN15	DN20	DN25
Burner connection "R" and "T1" (feed + return pipe)		Rp1/2"	Rp3/4"	Rp1"	Rp1"
Delivery pressure (depending on air venting way)	manual	min 1 bar / max 2,5 bar			
	automatic	1 bar			
Volume pressure tank	dm ³	6	12	22	22
Dimension L x B	mm	1050 x 360	1300 x 400	1300 x 400	1300 x 400
Code		on request	on request	on request	on request

Notes:

- oil supply pressure (pressure range) is created by separate force pump in ring pipeline or by lift of tank to greater height;
- for oil feed line of monoblock burners, operating with oil EL and L (heavy oil M and S on request);
- suits for equipment in accordance with DIN 4755/2, TRD 411, TRD 604.

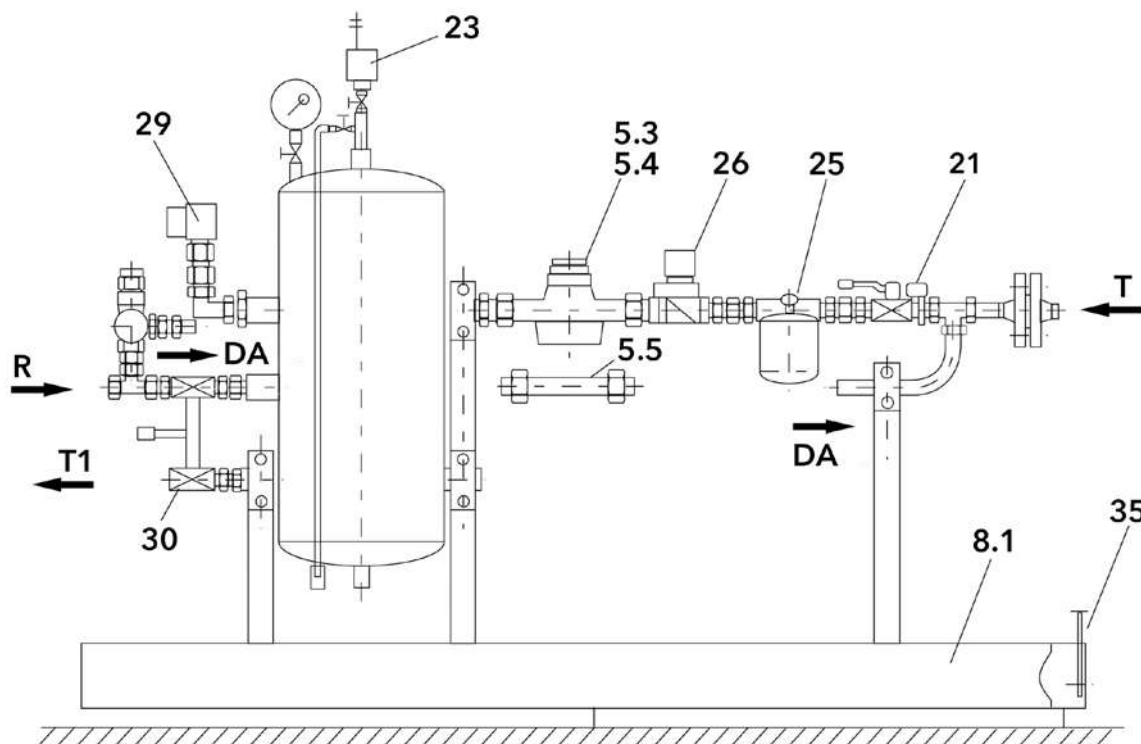

Ref.	Description	LBA 600 A	LBA 1200 A	LBA 2400 A	LBA 3000 A
5.3	Fuel rate counter with pulse transducer (Reed)	0,1 l / Imp	0,1 l / Imp	1 l / Imp	1 l / Imp
5.4	Fuel rate counter with inductive pulse transducer	0,01 l / Imp	0,01 l / Imp	0,01 l / Imp	0,1 l / Imp
5.5	Fitting for fuel rate counter (during maintenance)	Rp3/4"	Rp3/4"	Rp1"	Rp1"1/4
8.1	Extended fuel collector for options M, DM, DK	This option needs when choice od options M and/or DK			
21	Limit switch for ball valve (position 1)	230 V / 50 Hz / IP65, mounted onto ball valve. Tested at installation.			
23	Automatic air valve	Rp3/8", PN16, 150°C	Rp3/8", PN16, 150°C	Rp3/8", PN16, 150°C	Rp3/8", PN16, 150°C
25	Fuel filter	Rp1/2"	Rp1/2"	Rp3/4"	Rp1"
26	Safety electromagnetic valve	Rp1/2"	Rp1/2"	Rp3/4"	Rp1"
29	Oil pressure switch	Rp1/2", 230 V / 50 Hz / IP54, setting range 0,2...2,5 bar			
30	Two ball valves combination	Rp1/2"	Rp3/4"	Rp1"	Rp1"
35	Leakage control built in fuel collector	230 V / 50 Hz / IP65	230 V / 50 Hz / IP65	230 V / 50 Hz / IP65	230 V / 50 Hz / IP65

Codes on request.

OIL CONNECTION UNIT

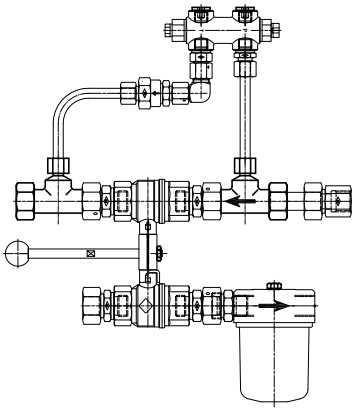

Unit consists of:
 - double ball valve (with or without limit switch);
 - oil filter
 - safety valve with relief valve, non return valve
 - pipes, threaded connections, seals

Unit with double ball valve with limit switch	Rp 1/2"	3755291
	Rp 3/4"	3754259
	Rp 1"	3755292
Unit with double ball valve without limit switch	Rp 1/2"	14037863
	Rp 3/4"	14037874
	Rp 1"	14037885

MANOMETER

	Manometer/vacuometer glycerine-filled Connection Rp1/2" A radial	-1...+3 bar	1098748467
		-1...+5 bar	1098748478
		0...4 bar	1098748489
		0...6 bar	3333116345
		0...10 bar	1098748490
		0...16 bar	1098585471
		0...25 bar	3333261128
		0...40 bar	1090160374
		0...60 bar	1098114290
	Kit manometer hydraulic block N6/N7		



LEAKAGE CONTROL DEVICE

	Signal device for oil for wall mounting LMW with 1 optoelectronic detector, signal part in housing HxBxT=140x85x60mm 230 V / 50-60 Hz / IP40	
	with cable 1,5 m	3755932
	with cable 15 m	3755933
	with cable 30 m	3755934

AIR VALVE

Automatic air valve with ball valve Rp3/8"	1478812577
--	------------

RELIEF/PRESSURE MAINTAINING VALVE

		Connection (DN)	Fuel rate	Pressure	
 <p>Threaded design, directly adjustable, with spring load for keeping adjusted working and max pressure, viscosity range 2,8...480 cSt</p>	1/4"	6...120 l/h	0,5...1,5 bar	1478812044	
			1...4 bar	1478730083	
			2...9 bar	1478731940	
		15...160 l/h	0,5...1,5 bar	1478812055	
			1...4 bar	1478812066	
			2...9 bar	1478812077	
	1/2"	30... 600 l/h	0,5...1,5 bar	1478812088	
			1...4 bar	1478720874	
	3/4"	100...2000 l/h	2...9 bar	1478812099	
			0,5...3,5 bar	1478812102	
	1"	300...6000 l/h	2...9 bar	1478812113	
			0,5...1,5 bar	1478812124	
			1...4 bar	1478812135	
	1"1/4	500...10000 l/h	2...9 bar	1478812146	
0,5...1,5 bar			1478812157		
1...4 bar			12001314		
 <p>Flanged design, directly adjustable, with spring load for keeping adjusted working and max pressure, viscosity range 2,8...480 cSt</p>	DN15	30...600 l/h	0,5...1,5 bar	1478812179	
			1...4 bar	1478729973	
			2...9 bar	1478812180	
	DN20	100...2000 l/h	0,5...3,5 bar	1478812191	
			2...9 bar	1478812204	
	DN25	300...6000 l/h	0,5...1,5 bar	1478812215	
			1...4 bar	1478785851	
	DN32	500...10000 l/h	2...9 bar	1478812226	
			0,5...1,5 bar	1478812237	
			1...4 bar	1478812248	
				2...9 bar	1478812259

WELDED FLANGE

	Welded flange PN 16 according to DIN 2633, form C from RSt 37-2 as external flange for oil mounting PN16	DN15	5318675203
		DN20	3333101876
		DN25	5318353059
		DN32	5318704652
		DN40 x 42 mm	5318353048
		DN50 x 45 mm	5318428082
	Welded flange PN40 according to DIN 2635, form C from C22 as external flange for oil mounting PN40	DN15	5318557486
		DN20	3333101916
		DN25	5318556494
		DN32	5318556507
		DN40 x 42 mm	5318556518
		DN50 x 45 mm	5318575308

SEALS AND CONNECTING KIT

Screwing set: 1 seal, pin screws, hexagon nuts, lining washer	DN15 PN16 / PN40	3752201
	DN20 PN16 / PN40	3752202
	DN25 PN16 / PN40	3752203

BALL VALVE

0...60°C for 64 bar, 0...120°C for 40 bar, 20...150°C for 30 bar	1/4"	1478736157
	1/2"	1478736168
	3/4"	1478736179
	1"	1478736180
-20...150°C for 16 bar	DN25	1478732910
	DN32	1478732921
	DN40	1478732932
	DN50	1478732943
	DN65	1478732954
	DN80	1478732965
-20...120°C for 40 bar, -20...150°C for 30 bar	DN15	1478734938
	DN20	1478734949
	DN25	1478734950
	DN32	1478734961
	DN40	1478734972
	DN50	1478734983

LIGHT OIL FILTER

100 ... 500 l/h	Rp3/8" male (burner side) / female - 70 µm - one pipe	3333110172
100 ... 500 l/h	Rp3/8" male (burner side) / female - 75 µm - one pipe	3333115482
200 ... 700 l/h	Rp1/2" male (burner side) / female - 75 µm - one pipe	3333115483
100 ... 500 l/h	Rp3/8" male (burner side) / female - 70 µm - two pipes	3333110175
100 ... 500 l/h	Rp3/8" male (burner side) / female - 75 µm - two pipes	3333110176
200 ... 700 l/h	Rp1/2" male (burner side) / female - 75 µm - two pipes	3333110174

OIL FILTER FD FOR SUCTION AND PRESSURE OPERATION

 Oil pressure max. 2 bar	Rp 1/2" - 700 l/h	3754100
	Rp 3/4" - 1700 l/h	3754101
	Rp 1" - 2000 l/h	3754102

LIGHT OIL FLOW COUNTER

Without pulse transducer	10 ... 400 l/h 16 bar Rp1/2"	1368746803
	10 ... 400 l/h 16 bar DN15	1368746892
	30 ... 1000 l/h 16 bar Rp3/4"	1368746836
	30 ... 1000 l/h 16 bar DN20	1368746927
	75 ... 2000 l/h 16 bar Rp1"	1368746869
	75 ... 2000 l/h 16 bar DN25	1368746950
With pulse transducer RV 0,1 (Reed)	10 ... 400 l/h 16 bar Rp1/2"	1368746814
	10 ... 400 l/h 16 bar DN15	1368746905
	30 ... 1000 l/h 16 bar Rp3/4"	1368746847
	30 ... 1000 l/h 16 bar DN20	1368746938
	75 ... 2000 l/h 16 bar Rp1"	1368746870
	75 ... 2000 l/h 16 bar DN25	1368746961
With pulse transducer IN 0,01 (Inductive)	10 ... 400 l/h 16 bar Rp1/2"	1368746825
	10 ... 400 l/h 16 bar DN15	1368746916
	30 ... 1000 l/h 16 bar Rp3/4"	1368746858
	30 ... 1000 l/h 16 bar DN20	1368746949
	75 ... 2000 l/h 16 bar Rp1"	1368746881
	75 ... 2000 l/h 16 bar DN25	1368746972
Threaded connection	VSR - Rp1/2"	3753933
	VSR - Rp3/4"	3754536
	VSR - Rp1"	3755097

Subsidiaries ELCO

GERMANY

ELCO GmbH
Dreieichstraße 10
Mörfelden-Walldorf
Tel. +49 (0)6105 287-287
Fax +49 (0)6105 287-199

NETHERLANDS

Elco Burners B.V.
Meerpaalweg, 1
1332 BB Almere
P.O. box 30048
1303 AA Almere
Tel. +31 088 69 573 11
Fax +31 088 69 573 90

FRANCE

14, rue du Saule Trapu
Parc d'activité du Moulin
91882 Massy
Tel. +33 01 60 13 64 64
Fax +33 01 60 13 64 65

SWITZERLAND

Elcotherm AG
Sarganserstrasse 100
7324 Vilters
Tel. +41 (0)81 725 25 25
Fax +41 (0)81 723 13 59

AUSTRIA

ELCO Austria GmbH
Aredstraße 16 - 18
2544 Leobersdorf
Tel. +43 (0)2256 639 99 32
Fax +43 (0)2256 644 11

ITALY

Via Roma, 64
31023 Resana (TV)
Tel. +39 0423 719 500
Fax +39 0423 719 580

UK & IRELAND

Ariston Thermo UK Ltd
Suite 3, The Crown House
Blackpole East, Blackpole Road,
Worcester WR3 8SG
Tel. +44 01905 788010
Fax +44 01905 788011

RUSSIA

Ariston Thermo RUS
Eniseyskaya str. 1, bld 1,
Office Center "LIRA" #438
129344 Moscow
Tel. +7 495 213 0300 #5700
Fax +7 495 213 0302

CHINA

Ariston Thermo (China) Co., Ltd.
F/15, V-Capital Bldg
No. 333 Xian Xia Road
200336 Shanghai
Tel. +86 21 6039 8691
Fax +86 21 6039 8620

Contact us to know more
about our products and solutions

www.elco-burners.com
contact@elco-burners.com