

HTC 105 S/30.60

CONCRETE CASTING BURNER CONE

HTC 105 S/30 - MV Ø60

Maximum output [kW]		105
Fuel pressure at maximum capacity [mbar] (measured at P _{1,F} - pag. 2)	Natural gas (8250 kcal/Nm ³)	35
	LPG (22500 kcal/Nm ³)	
Air pressure at maximum capacity [mbar] (measured at P _{1,A} - pag. 2)	Natural gas (8250 kcal/Nm ³)	38
	LPG (22500 kcal/Nm ³)	
Flame length at maximum capacity [mm] (measured from the end of the burner body)	Natural gas (8250 kcal/Nm ³)	650
	LPG (22500 kcal/Nm ³)	
Flame speed at maximum capacity [m/s] (with 20% excess of air)	Medium speed	65
Flame detection	Ionization flame detection electrode or UV cell	
Fuel	Natural gas, LPG	

All information is based on laboratory tests in a neutral pressure chamber. Different conditions and chamber sizes can affect the data.

All information is based on a standard combustor design. Modifications to the combustor will alter performance and pressures.

All data are based on gross calorific values.

All information is based on tests conducted on generally acceptable air and gas piping systems.

Data reported in this technical sheet are subject to change without notice.

Performance data and dimensions are guidelines only and are not binding.

ELCO reserves the right to modify the construction and / or configuration of its products at any time

CHARACTERISTICS OF THE BURNER

Fuel 1: CH₄
 Fuel 1 diaphragm: Ø8.5

Fuel 2: LPG
 Fuel 2 diaphragm: Ø7.25

Comburent: Air
 Comburent diap.: Gr.26%

Cone: Ø60

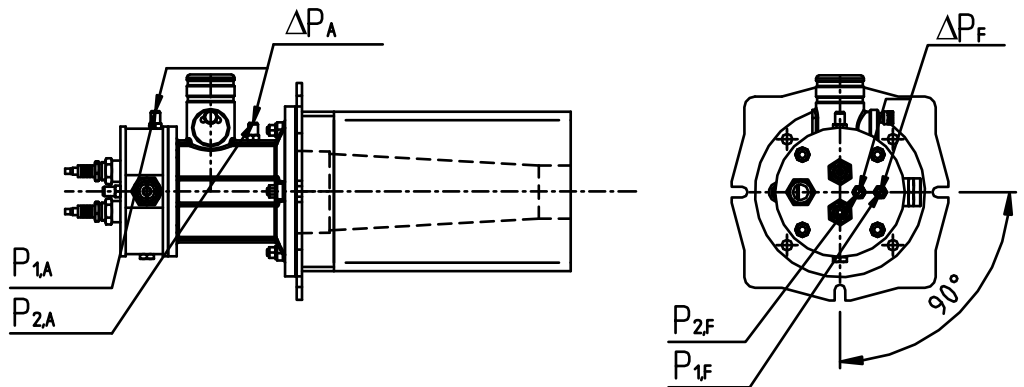

OPERATING RANGE

TYPICAL OPERATING RANGE

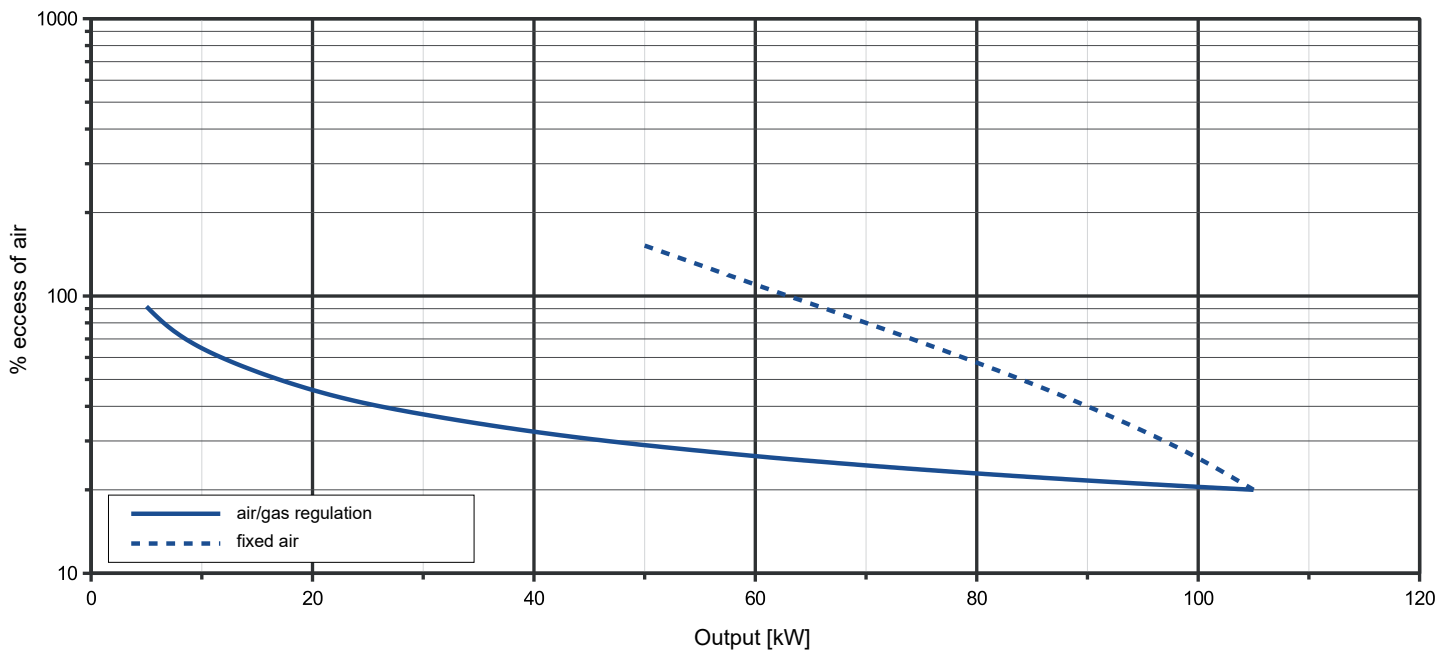

LEGENDA

Q_F Fuel flow
 Q_A Air flow

$P_{1,F}$ Fuel pressure upstream the diaphragm
 $P_{1,A}$ Air pressure upstream the diaphragm
 $P_{2,F}$ Fuel pressure downstream the diaphragm

$P_{2,A}$ Air pressure downstream the diaphragm
 ΔP_F Differential fuel pressure between ports 1 and 2
 ΔP_A Differential air pressure between ports 1 and 2

FLOW RATE CURVES

Q_F [Nm ³ /h]	FUEL	
	$P_{1,F}$ [mbar] Natural gas	ΔP_F [mbar] Natural gas
0.5	0.07	0.03
1	0.28	0.13
1.5	0.64	0.29
2	1.13	0.51
2.5	1.77	0.79
3	2.54	1.14
3.5	3.46	1.55
4	4.52	2.03
4.5	5.72	2.57
5	7.06	3.17
5.5	8.55	3.83
6	10.17	4.56
6.5	11.94	5.36
7	13.84	6.21
7.5	15.89	7.13
8	18.08	8.11
8.5	20.41	9.16
9	22.88	10.27
9.5	25.49	11.44
10	28.25	12.68
10.5	31.14	13.98
11	34.18	15.34
11.5	37.36	16.77
12	40.68	18.25

Q_A [Nm ³ /h]	AIR	
	$P_{1,A}$ [mbar]	ΔP_A [mbar]
5	0.06	0.03
10	0.22	0.11
15	0.50	0.24
20	0.88	0.43
30	1.99	0.96
40	3.54	1.71
50	5.53	2.67
55	6.69	3.23
60	7.96	3.84
65	9.34	4.51
70	10.84	5.23
75	12.44	6.00
80	14.15	6.83
85	15.98	7.71
90	17.91	8.64
95	19.96	9.63
100	22.11	10.67
105	24.38	11.76
110	26.76	12.91
115	29.25	14.11
120	31.84	15.37
125	34.55	16.67
130	37.37	18.03
135	40.30	19.45

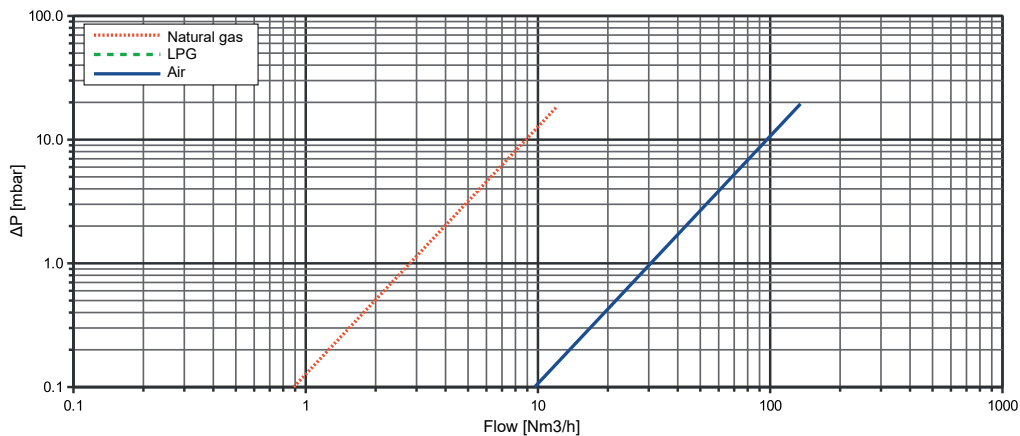
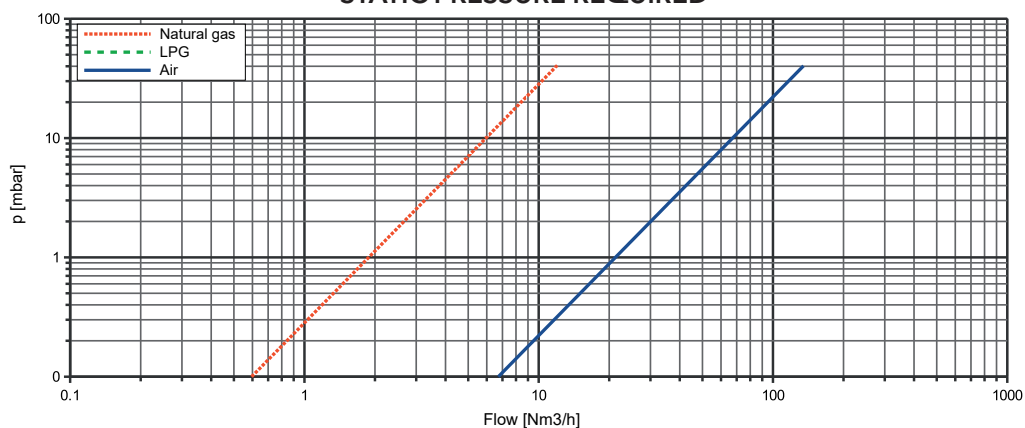
STATIC PRESSURE REQUIRED

DIMENSIONS [mm]

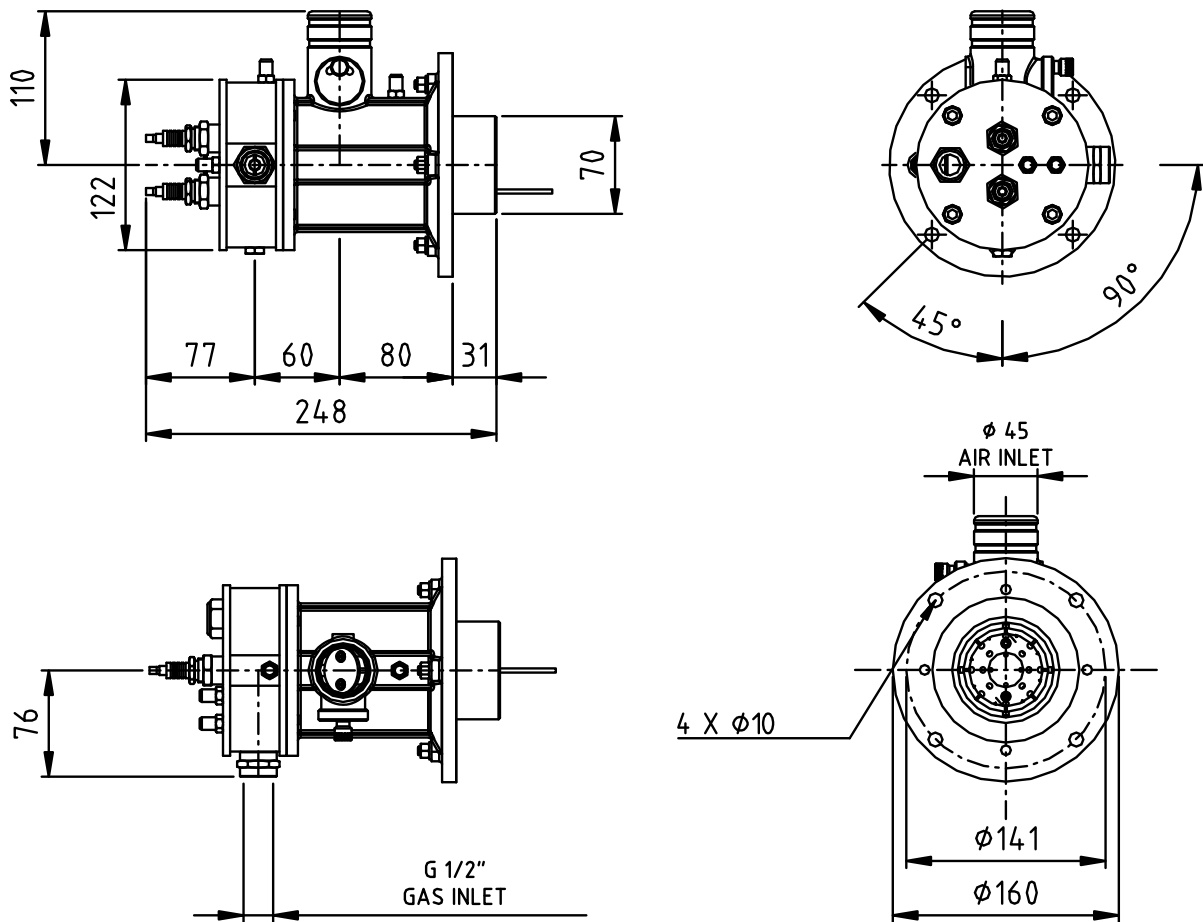

Concrete casting cone:

