

HTC 300 S0.150

CONCRETE CASTING BURNER CONE

HTC 300 S0 - LV Ø150

Maximum output [kW]		300
Fuel pressure at maximum capacity [mbar] (measured at P _{1,F} - pag. 2)	Natural gas (8250 kcal/Nm ³)	18
	LPG (22500 kcal/Nm ³)	20
Air pressure at maximum capacity [mbar] (measured at P _{1,A} - pag. 2)	Natural gas (8250 kcal/Nm ³)	22
	LPG (22500 kcal/Nm ³)	
Flame length at maximum capacity [mm] (measured from the end of the burner body)	Natural gas (8250 kcal/Nm ³)	500
	LPG (22500 kcal/Nm ³)	500
Flame speed at maximum capacity [m/s] (with 20% excess of air)	Low speed	29
Flame detection	Ionization flame detection electrode or UV cell	
Fuel	Natural gas, LPG	

All information is based on laboratory tests in a neutral pressure chamber. Different conditions and chamber sizes can affect the data.

All information is based on a standard combustor design. Modifications to the combustor will alter performance and pressures.

All data are based on gross calorific values.

All information is based on tests conducted on generally acceptable air and gas piping systems.

Data reported in this technical sheet are subject to change without notice.

Performance data and dimensions are guidelines only and are not binding.

ELCO reserves the right to modify the construction and / or configuration of its products at any time

CHARACTERISTICS OF THE BURNER

Fuel 1: CH₄
 Fuel 1 diaphragm: Ø20

Fuel 2: LPG
 Fuel 2 diaphragm: Ø15

Comburent: Air
 Comburent diap.: Ø100

Cone: Ø150

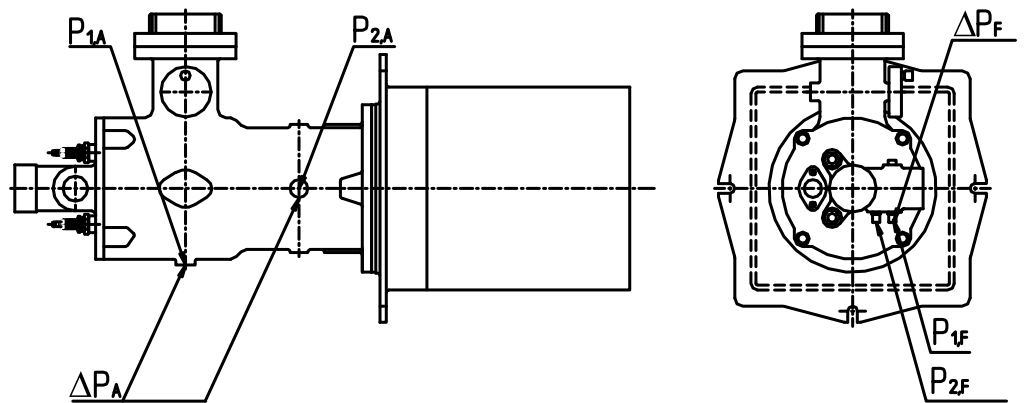

OPERATING RANGE

TYPICAL OPERATING RANGE

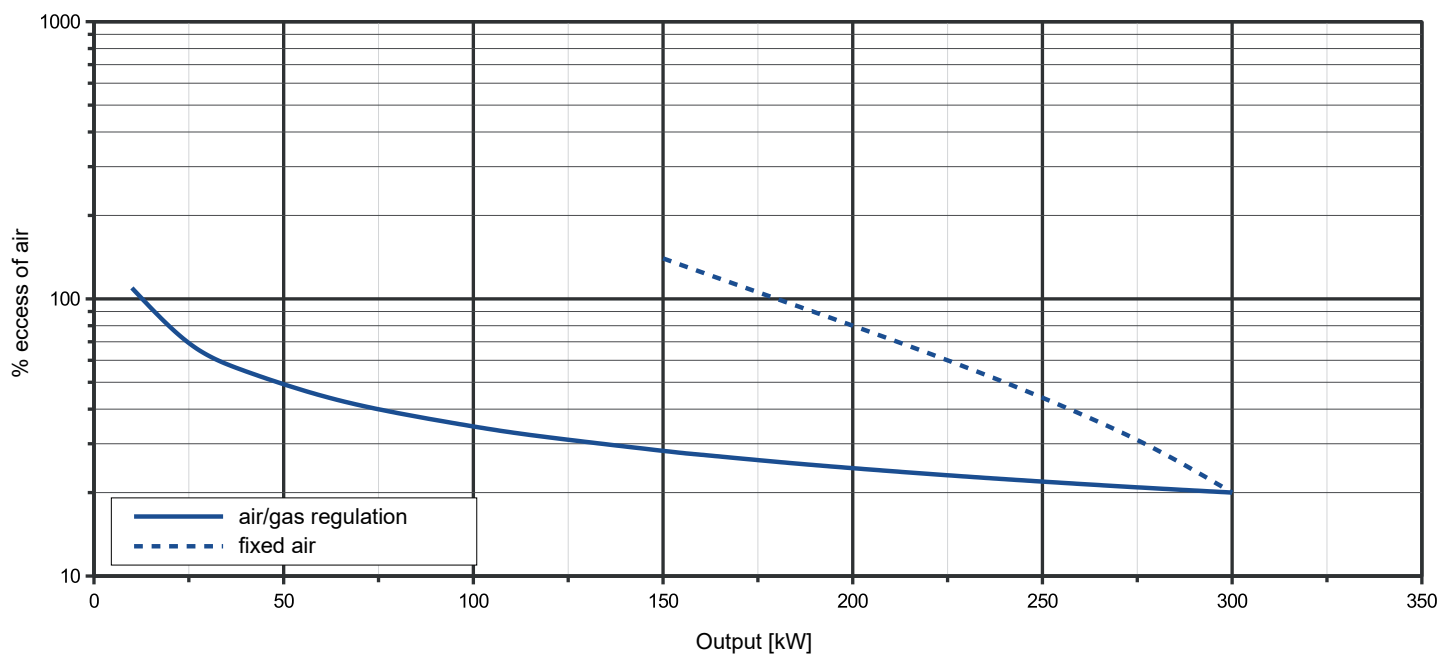

LEGENDA

Q_F Fuel flow
 Q_A Air flow

$P_{1,F}$ Fuel pressure upstream the diaphragm
 $P_{1,A}$ Air pressure upstream the diaphragm
 $P_{2,F}$ Fuel pressure downstream the diaphragm

$P_{2,A}$ Air pressure downstream the diaphragm
 ΔP_F Differential fuel pressure between ports 1 and 2
 ΔP_A Differential air pressure between ports 1 and 2

FLOW RATE CURVES

Q_F [Nm ³ /h]	FUEL			
	$P_{1,F}$ [mbar]		ΔP_F [mbar]	
	Natural gas	LPG	Natural gas	LPG
1	0.02	0.13	0.00	0.03
2	0.07	0.53	0.01	0.11
3	0.15	1.19	0.02	0.24
4	0.26	2.11	0.04	0.42
5	0.41	3.30	0.06	0.66
6	0.59	4.76	0.09	0.95
8	1.04	8.45	0.16	1.69
10	1.63	13.21	0.25	2.64
12	2.35	19.02	0.36	3.80
14	3.20		0.48	
16	4.18		0.63	
18	5.29		0.80	
20	6.53		0.99	
22	7.90		1.19	
23	8.64		1.30	
24	9.40		1.42	
25	10.21		1.54	
26	11.04		1.67	
27	11.90		1.80	
28	12.80		1.93	
29	13.73		2.07	
30	14.70		2.22	
31	15.69		2.37	
32	16.72		2.53	

Q_A [Nm ³ /h]	AIR	
	$P_{1,A}$ [mbar]	ΔP_A [mbar]
50	0.37	0.17
60	0.54	0.25
80	0.96	0.45
100	1.50	0.70
120	2.16	1.00
140	2.93	1.36
160	3.83	1.78
180	4.85	2.26
200	5.99	2.78
220	7.24	3.37
240	8.62	4.01
250	9.35	4.35
260	10.12	4.71
270	10.91	5.07
280	11.73	5.46
290	12.59	5.85
300	13.47	6.26
310	14.38	6.69
320	15.33	7.13
330	16.30	7.58
340	17.30	8.05
350	18.33	8.53
360	19.40	9.02
370	20.49	9.53

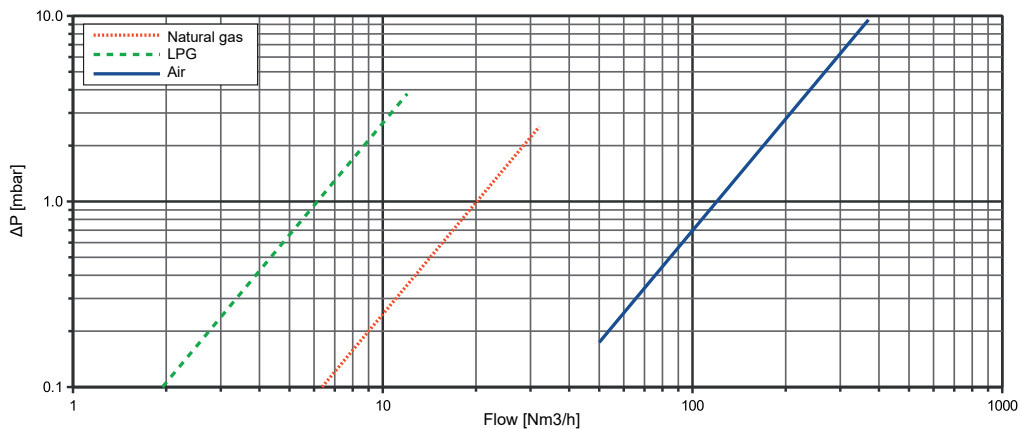

STATIC PRESSURE REQUIRED

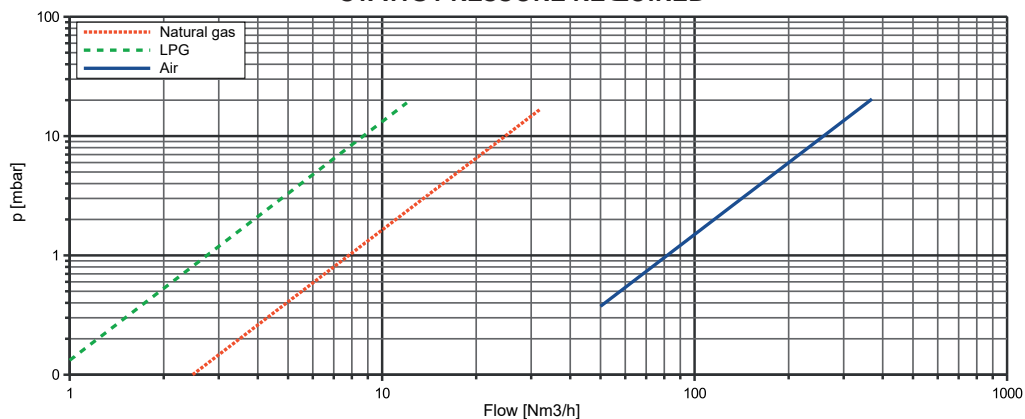

DIMENSIONS [mm]

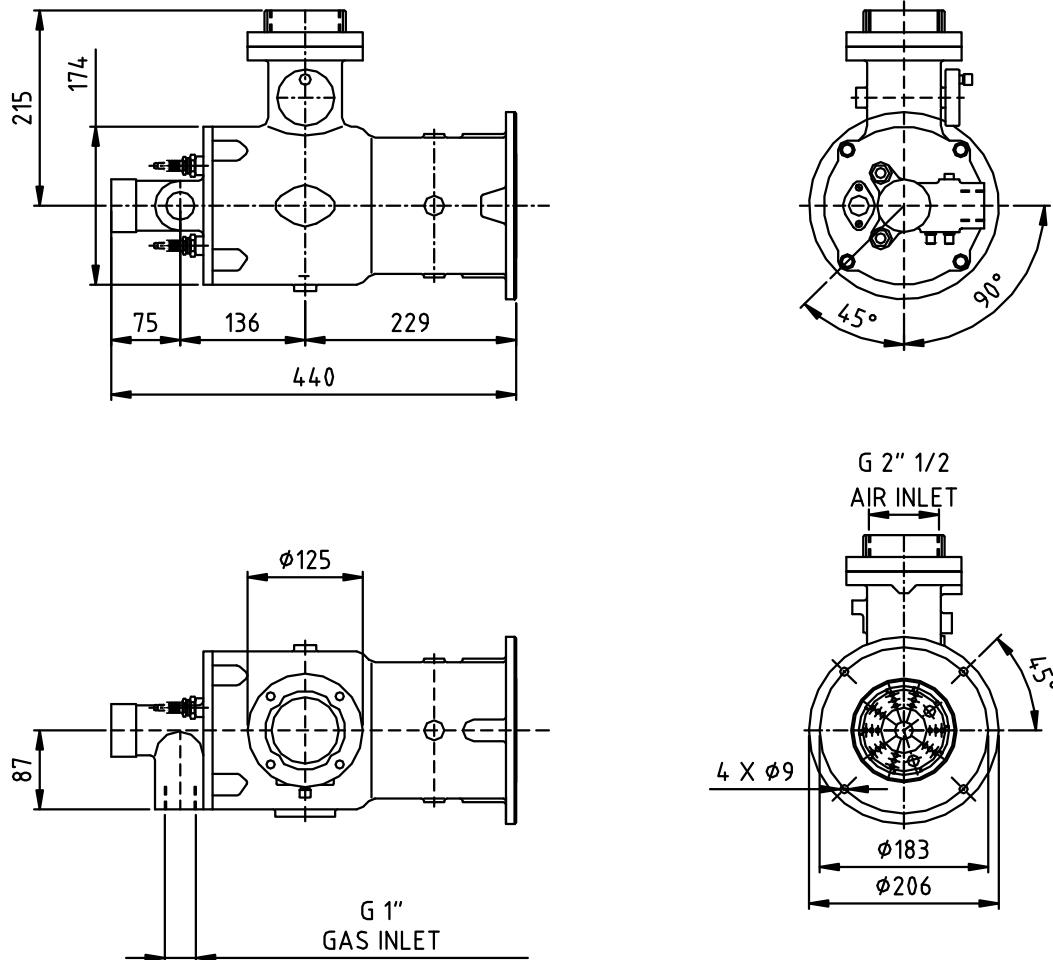

Concrete casting cone:

