

HTC 2325 S/O PC.225

CONCRETE CASTING BURNER CONE

HTC 2325 S/O PC - MV Ø225

Maximum output [kW]		2325
Fuel pressure at maximum capacity [mbar] (measured at P _{1,F} - pag. 2)	Natural gas (8250 kcal/Nm ³)	42
	LPG (22500 kcal/Nm ³)	
Air pressure at maximum capacity [mbar] (measured at P _{1,A} - pag. 2)	Natural gas (8250 kcal/Nm ³)	64
	LPG (22500 kcal/Nm ³)	
Flame length at maximum capacity [mm] (measured from the end of the burner body)	Natural gas (8250 kcal/Nm ³)	2000
	LPG (22500 kcal/Nm ³)	
Flame speed at maximum capacity [m/s] (with 20% excess of air)	Medium speed	95
Flame detection	Ionization flame detection electrode or UV cell	
Fuel	Natural gas, LPG	

All information is based on laboratory tests in a neutral pressure chamber. Different conditions and chamber sizes can affect the data.

All information is based on a standard combustor design. Modifications to the combustor will alter performance and pressures.

All data are based on gross calorific values.

All information is based on tests conducted on generally acceptable air and gas piping systems.

Data reported in this technical sheet are subject to change without notice.

Performance data and dimensions are guidelines only and are not binding.

ELCO reserves the right to modify the construction and / or configuration of its products at any time

CHARACTERISTICS OF THE BURNER

Fuel 1: CH₄
 Fuel 1 diaphragm: Ø42

Fuel 2: LPG
 Fuel 1 diaphragm: Ø26

Comburent: Air
 Comburent diap.: Ø170

Cone: Ø225

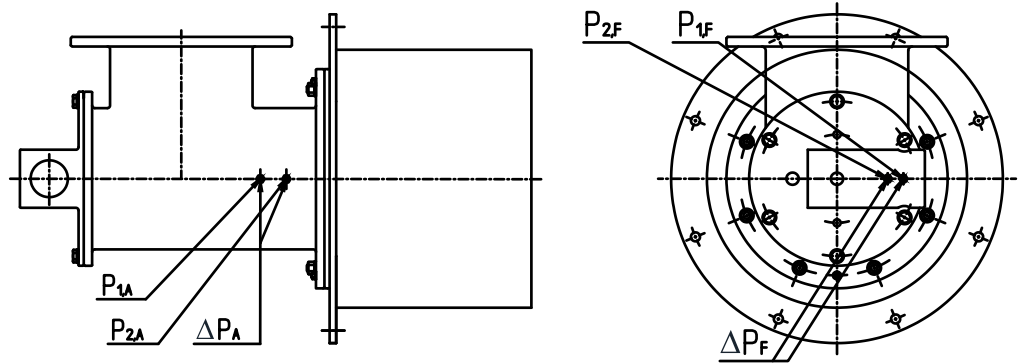

OPERATING RANGE

TYPICAL OPERATING RANGE

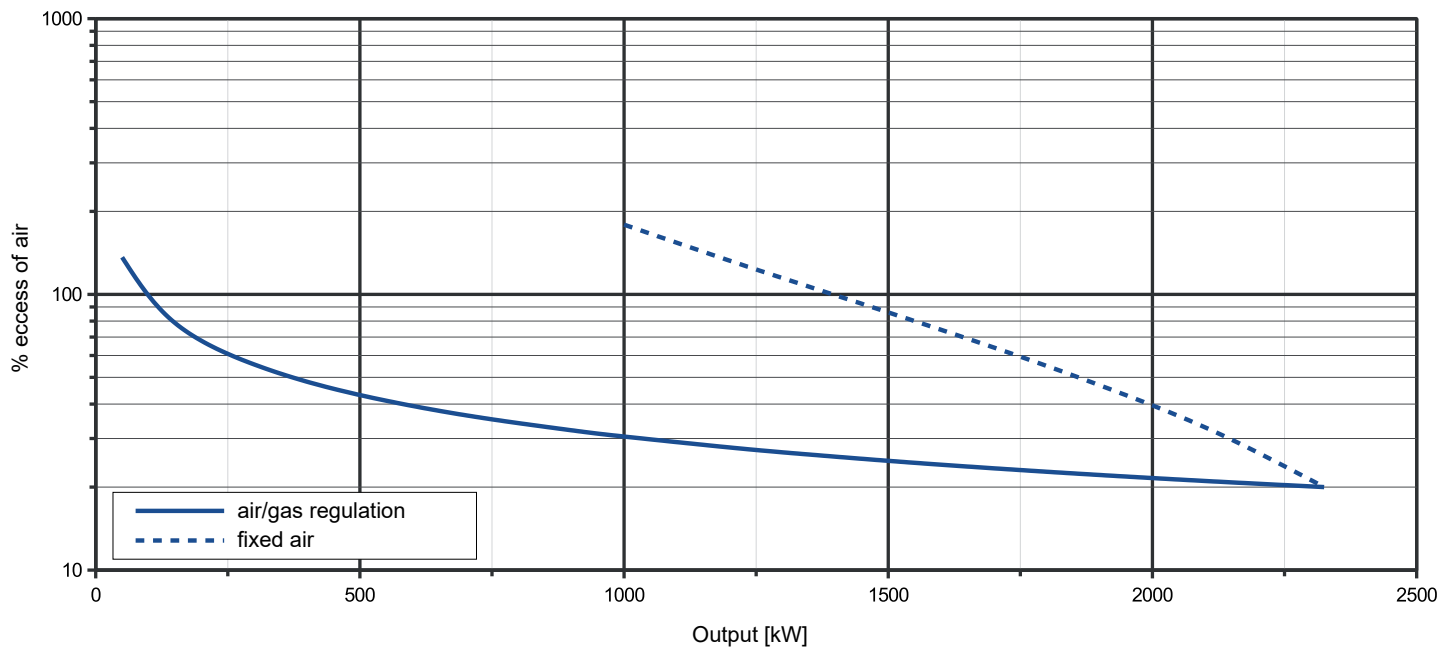

LEGENDA

Q_F Fuel flow
 Q_A Air flow

$P_{1,F}$ Fuel pressure upstream the diaphragm
 $P_{1,A}$ Air pressure upstream the diaphragm
 $P_{2,F}$ Fuel pressure downstream the diaphragm

$P_{2,A}$ Air pressure downstream the diaphragm
 ΔP_F Differential fuel pressure between ports 1 and 2
 ΔP_A Differential air pressure between ports 1 and 2

FLOW RATE CURVES

Q_F [Nm ³ /h]	FUEL			
	$P_{1,F}$ [mbar]		ΔP_F [mbar]	
	Natural gas	LPG	Natural gas	LPG
10	0.19		0.03	
20	0.46		0.08	
30	0.82		0.17	
40	1.26		0.28	
50	1.78		0.42	
60	2.38		0.59	
70	3.07		0.79	
80	3.83		1.01	
90	4.68		1.27	
100	5.61		1.55	
110	6.63		1.86	
120	7.72		2.20	
130	8.90		2.57	
140	10.16		2.97	
150	11.51		3.40	
160	12.93		3.85	
170	14.44		4.33	
180	16.03		4.85	
190	17.70		5.39	
200	19.46		5.95	
210	21.29		6.55	
220	23.21		7.18	
230	25.21		7.83	
242	27.72		8.65	

Q_A [Nm ³ /h]	AIR	
	$P_{1,A}$ [mbar]	ΔP_A [mbar]
120	0.06	0.02
240	0.26	0.10
360	0.58	0.22
480	1.27	0.57
600	2.19	1.06
720	3.35	1.70
840	4.76	2.47
960	6.41	3.38
1080	8.31	4.43
1200	10.44	5.61
1320	12.82	6.94
1440	15.44	8.41
1560	18.31	10.02
1680	21.42	11.76
1800	24.77	13.65
1920	28.36	15.68
2040	32.19	17.84
2160	36.27	20.14
2280	40.59	22.59
2400	45.15	25.17
2520	49.96	27.89
2640	55.01	30.75
2760	60.30	33.76
2900	66.78	37.43

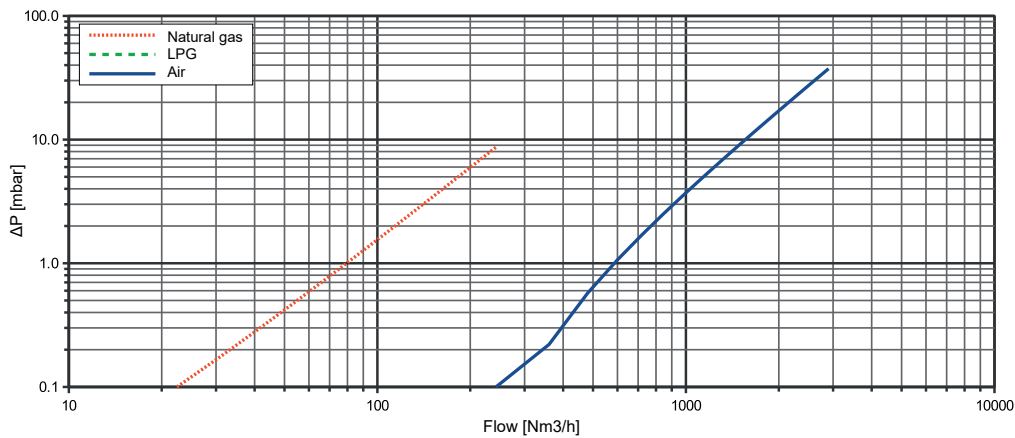

STATIC PRESSURE REQUIRED

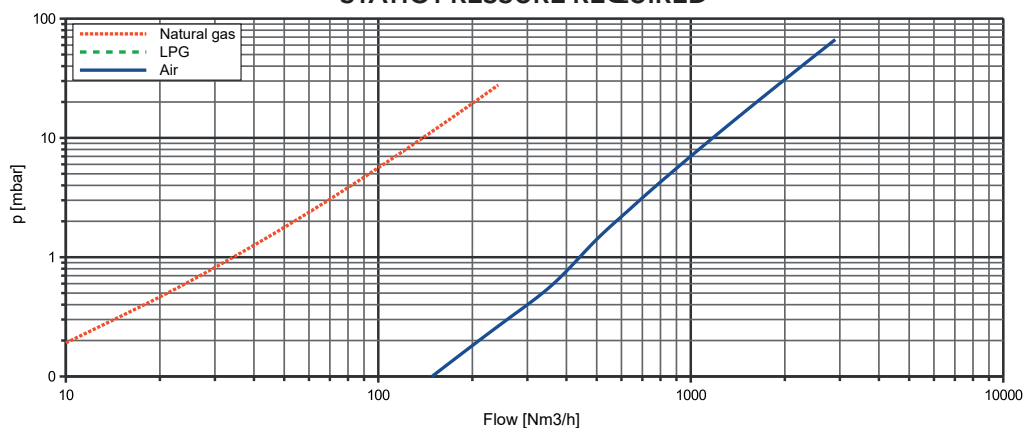

DIMENSIONS [mm]

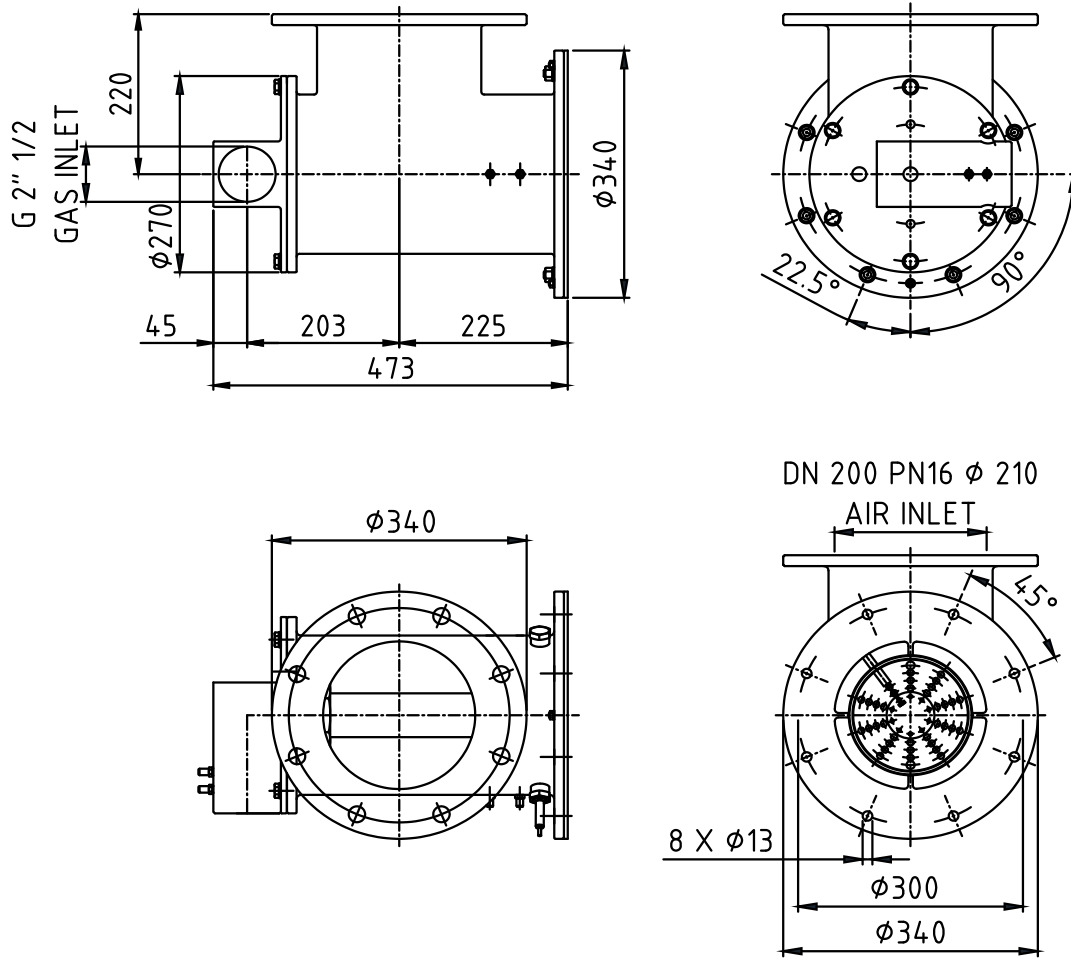

Concrete casting cone:

