

MB LMT 235

Monoblock High Ratio Regulation

THERMAL STEEL FLAME TUBE

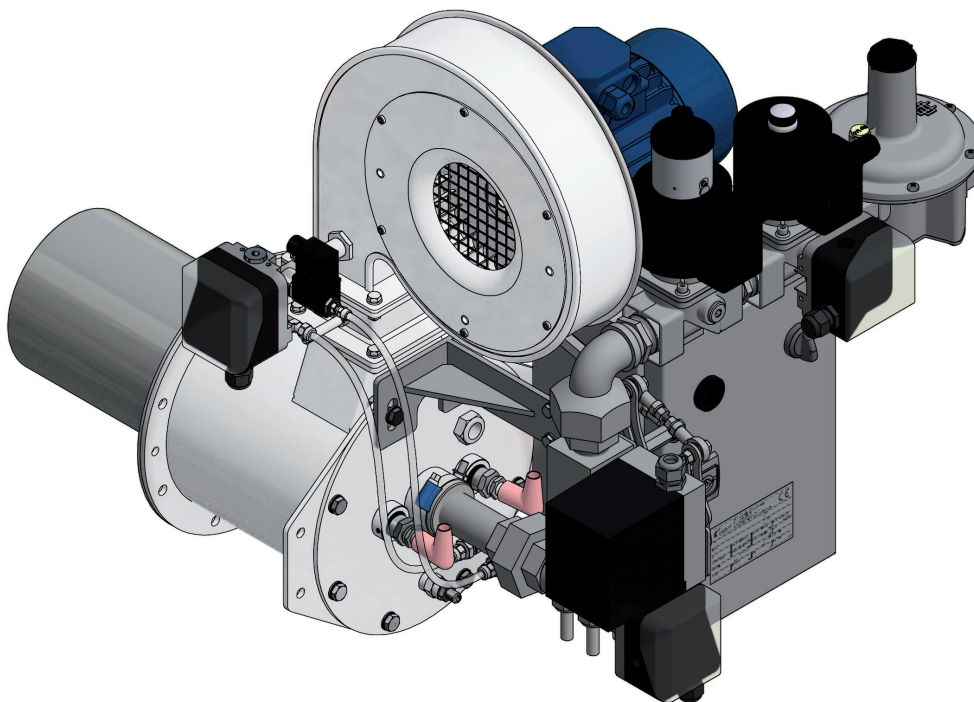

MB LMT 235

Maximum output [kW]		235
Minimum output (air/gas regulation) [kW]		8
Minimum output (fixed air) [kW]		10
Fuel pressure at maximum capacity (upstream of the stabilizer) [mbar]	Natural gas (8250 kcal/Nm ³)	35
	LPG (22500 kcal/Nm ³)	55
Operating conditions in the combustion chamber at maximum capacity [mbar]	Maximum back pressure	0
	Minimum depression	-8
Flame length at maximum capacity [mm] (measured at the end of the burner body)	Natural gas (8250 kcal/Nm ³)	850
	LPG (22500 kcal/Nm ³)	900
Flame detection	Ionization flame detection electrode (UV cell on request)	
Fuel	Natural gas (LPG and other gaseous fuel on request)	

All information is based on laboratory tests in a neutral pressure chamber. Different conditions and chamber sizes can affect the data.

All information is based on a standard combustor design. Modifications to the combustor will alter performance and pressures.

All data are based on gross calorific values.

All information is based on tests conducted on generally acceptable air and gas piping systems.

Data reported in this technical sheet are subject to change without notice.

Performance data and dimensions are guidelines only and are not binding.

ECOFLAM reserves the right to modify the construction and / or configuration of its products at any time

CHARACTERISTICS OF THE BURNER

Fuel 1: CH₄
 Fuel 1 diaphragm: Ø**

Fuel 2: LPG
 Fuel 2 diaphragm: Ø**

Comburent: Air
 Comburent diaphragm: Sp.15

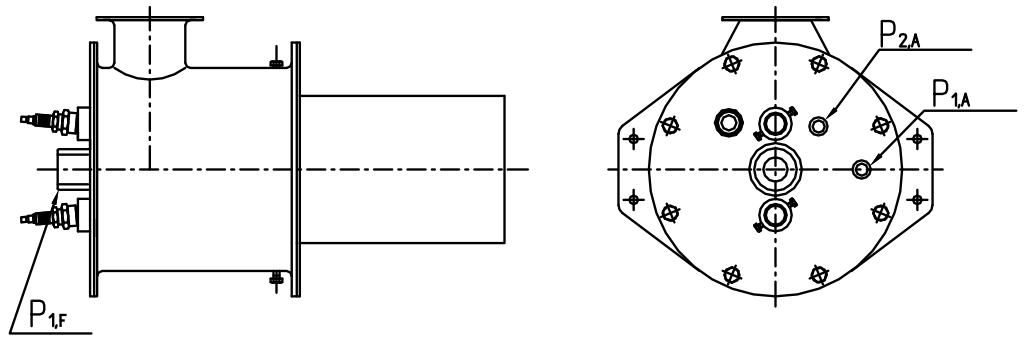

OPERATING RANGE

TYPICAL OPERATING RANGE

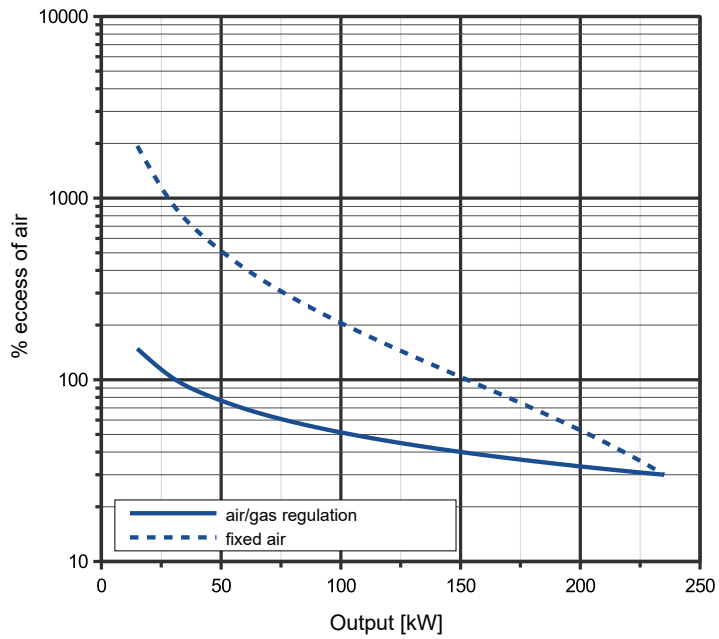

WORKING FIELD

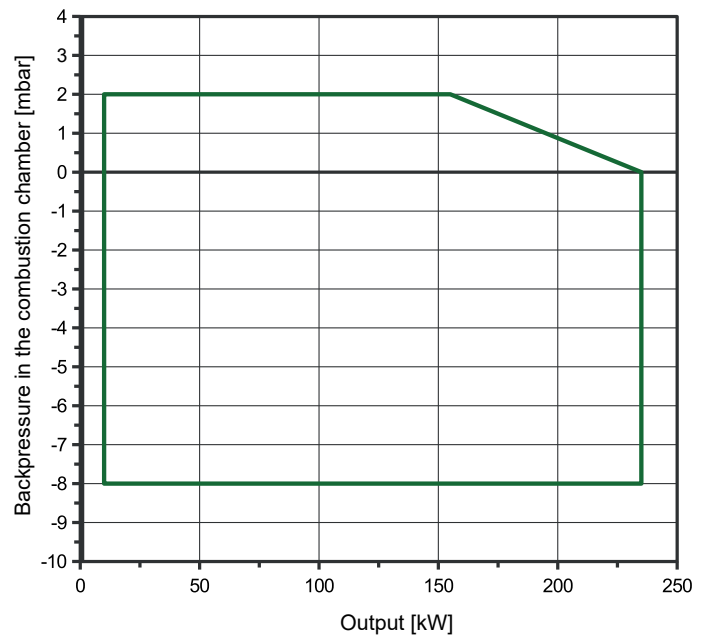

LEGENDA

Q_F Fuel flow

$P_{1,F}$ Fuel pressure

$P_{2,A}$ Air pressure downstream the diaphragm

Q_A Air flow

$P_{1,A}$ Air pressure upstream the diaphragm

ΔP_A Differential pressure between ports 1 and 2

FLOW RATE CURVES

Q_F [Nm ³ /h]	FUEL	
	$P_{1,F}$ [mbar]	
	Natural gas	LPG
1	0.02	0.46
2	0.09	1.85
3	0.21	4.17
4	0.38	7.41
5	0.59	11.58
6	0.84	16.67
7	1.15	22.69
8	1.50	29.64
9	1.90	37.51
10	2.35	
11	2.84	
12	3.38	
13	3.96	
14	4.60	
15	5.28	
16	6.00	
17	6.78	
18	7.60	
19	8.47	
20	9.38	
21	10.34	
22	11.35	
23	12.41	
24	13.51	

Q_A [Nm ³ /h]	AIR	
	$P_{1,A}$	ΔP_A
	[mbar]	[mbar]
20	0.04	0.02
30	0.08	0.05
40	0.14	0.08
50	0.22	0.13
60	0.32	0.18
70	0.43	0.25
80	0.56	0.32
90	0.71	0.41
100	0.88	0.50
115	1.16	0.66
130	1.48	0.85
145	1.84	1.06
160	2.24	1.29
175	2.68	1.54
190	3.16	1.81
205	3.68	2.11
220	4.24	2.43
235	4.84	2.78
250	5.48	3.14
265	6.15	3.53
280	6.87	3.94
290	7.37	4.23
300	7.89	4.52
310	8.42	4.83

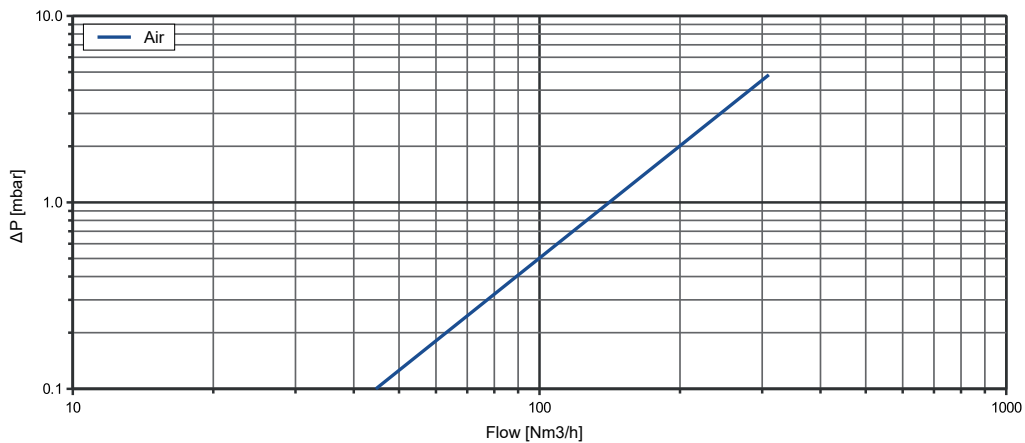

FUEL SUPPLY PRESSURE

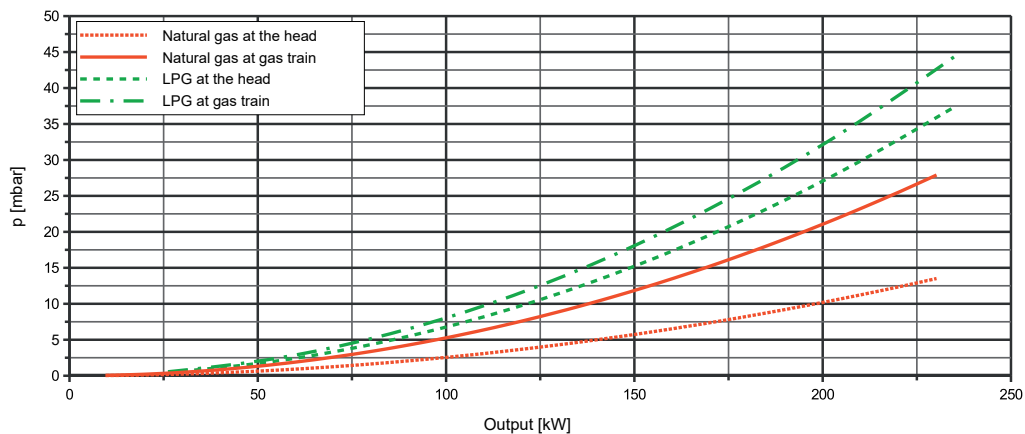

DIMENSIONS [mm]

