

HTC 220 S/0.62

CONCRETE CASTING BURNER CONE

HTC 220 S/0 - HV Ø62		
Maximum output [kW]		220
Fuel pressure at maximum capacity [mbar] (measured at P _{1,F} - pag. 2)	Natural gas (8250 kcal/Nm ³)	50
	LPG (22500 kcal/Nm ³)	
Air pressure at maximum capacity [mbar] (measured at P _{1,A} - pag. 2)	Natural gas (8250 kcal/Nm ³)	80
	LPG (22500 kcal/Nm ³)	
Flame length at maximum capacity [mm] (measured from the end of the burner body)	Natural gas (8250 kcal/Nm ³)	650
	LPG (22500 kcal/Nm ³)	
Flame speed at maximum capacity [m/s] (with 20% excess of air)	High speed	115
Flame detection	Ionization flame detection electrode or UV cell	
Fuel	Natural gas, LPG	

All information is based on laboratory tests in a neutral pressure chamber. Different conditions and chamber sizes can affect the data.

All information is based on a standard combustor design. Modifications to the combustor will alter performance and pressures.

All data are based on gross calorific values.

All information is based on tests conducted on generally acceptable air and gas piping systems.

Data reported in this technical sheet are subject to change without notice.

Performance data and dimensions are guidelines only and are not binding.

ECOFLAM reserves the right to modify the construction and / or configuration of its products at any time

CHARACTERISTICS OF THE BURNER

Fuel 1: CH₄
 Fuel 1 diaphragm: Ø13

Fuel 2: LPG
 Fuel 2 diaphragm: Ø10

Comburent: Air
 Comburent diap.: Ø78

Cone: Ø62

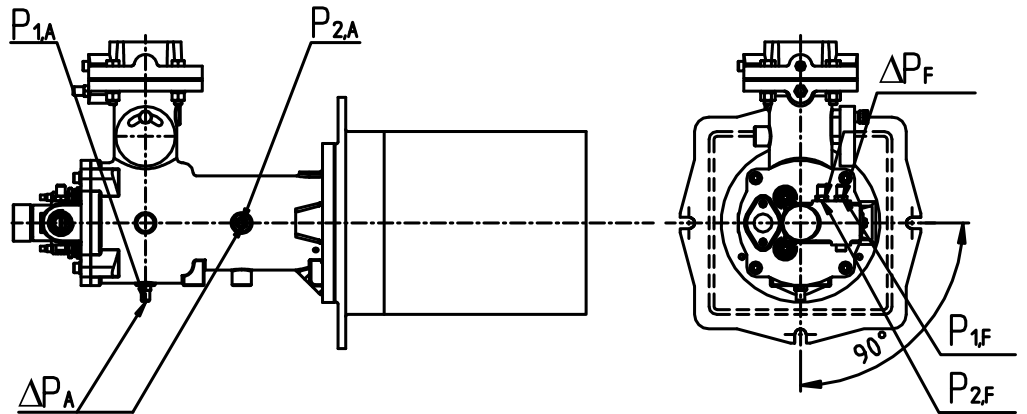

OPERATING RANGE

TYPICAL OPERATING RANGE

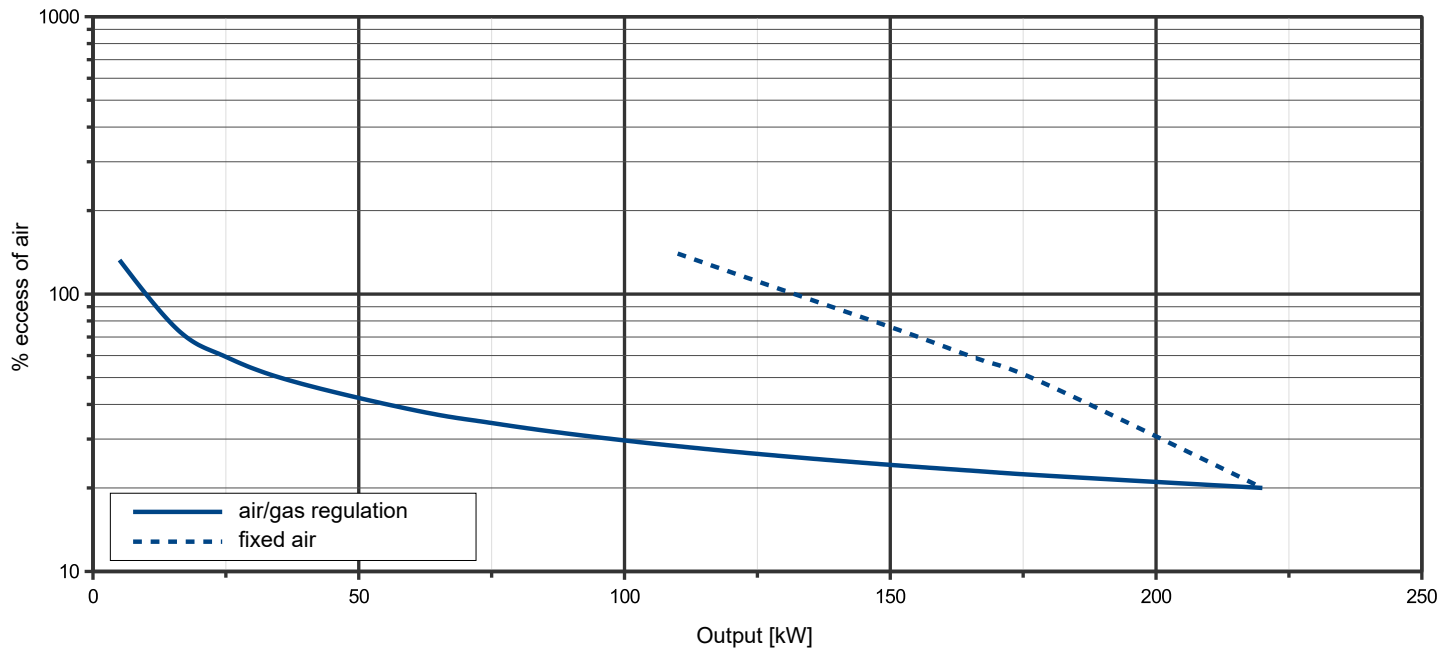

LEGENDA

Q_F Fuel flow
 Q_A Air flow

$P_{1,F}$ Fuel pressure upstream the diaphragm
 $P_{1,A}$ Air pressure upstream the diaphragm
 $P_{2,F}$ Fuel pressure downstream the diaphragm

$P_{2,A}$ Air pressure downstream the diaphragm
 ΔP_F Differential fuel pressure between ports 1 and 2
 ΔP_A Differential air pressure between ports 1 and 2

FLOW RATE CURVES

Q_F [Nm ³ /h]	FUEL	
	$P_{1,F}$ [mbar] Natural gas	ΔP_F [mbar] Natural gas
0.5	0.02	0.00
1	0.10	0.02
2	0.38	0.07
3	0.86	0.17
4	1.53	0.30
5	2.39	0.46
6	3.45	0.67
7	4.69	0.91
8	6.12	1.18
9	7.75	1.50
10	9.57	1.85
11	11.58	2.24
12	13.78	2.67
13	16.17	3.13
14	18.76	3.63
15	21.53	4.17
16	24.50	4.74
17	27.66	5.35
18	31.01	6.00
19	34.55	6.68
20	38.28	7.41
21	42.20	8.16
22	46.32	8.96
23	50.62	9.79

Q_A [Nm ³ /h]	AIR	
	$P_{1,A}$ [mbar]	ΔP_A [mbar]
15	0.24	0.06
30	0.98	0.23
45	2.20	0.52
60	3.91	0.92
75	6.11	1.44
90	8.80	2.07
100	10.87	2.56
110	13.15	3.10
120	15.65	3.68
130	18.37	4.32
140	21.30	5.01
150	24.45	5.76
160	27.82	6.55
170	31.41	7.39
180	35.21	8.29
190	39.23	9.23
200	43.47	10.23
210	47.93	11.28
220	52.60	12.38
230	57.49	13.53
240	62.60	14.73
250	67.93	15.99
260	73.47	17.29
270	79.23	18.65

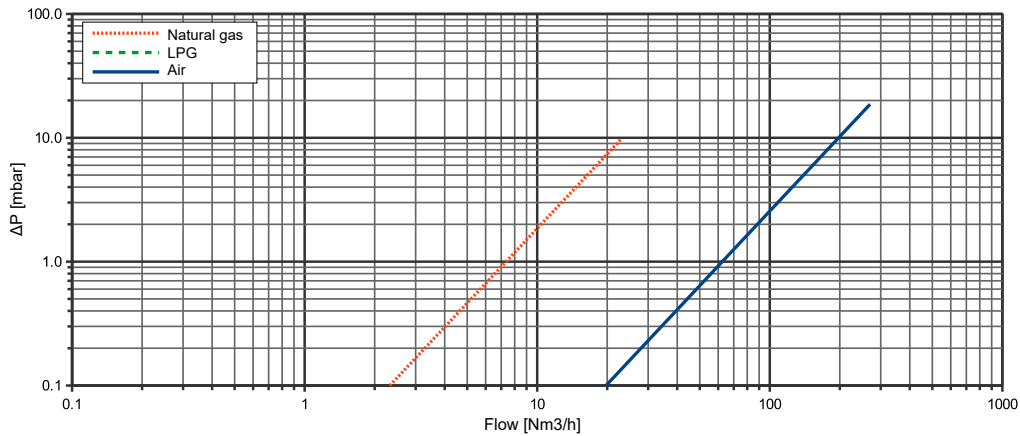

STATIC PRESSURE REQUIRED

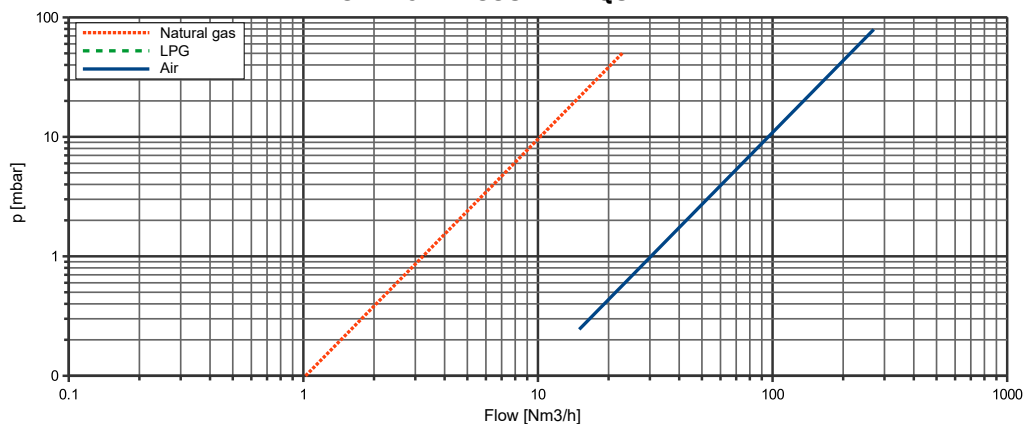

DIMENSIONS [mm]

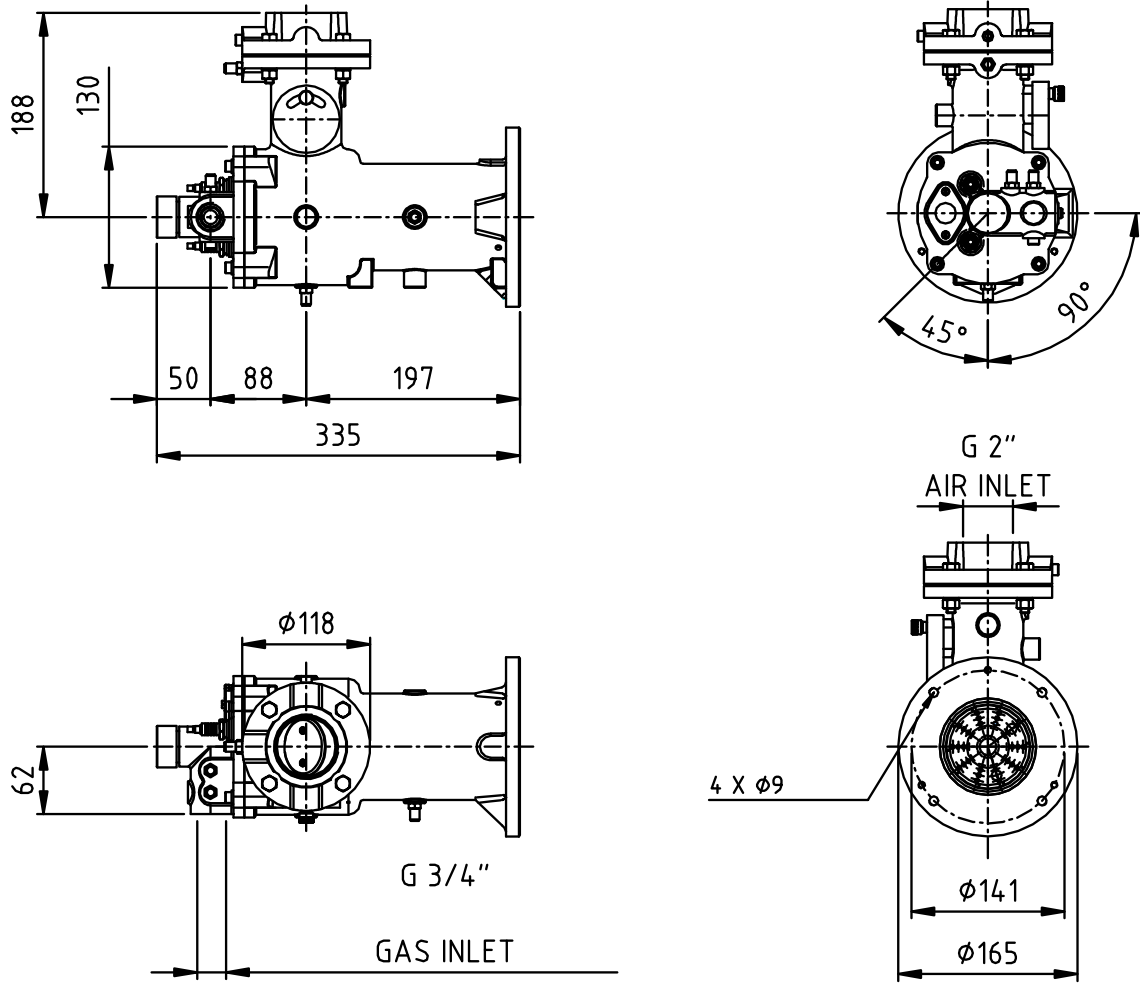

Concrete casting cone:

