

HTC 3500 S/O PC.330

CONCRETE CASTING BURNER CONE

HTC 3500 S/O PC - MV Ø330		
Maximum output [kW]		3500
Fuel pressure at maximum capacity [mbar] (measured at P _{1,F} - pag. 2)	Natural gas (8250 kcal/Nm ³)	35
	LPG (22500 kcal/Nm ³)	
Air pressure at maximum capacity [mbar] (measured at P _{1,A} - pag. 2)	Natural gas (8250 kcal/Nm ³)	35
	LPG (22500 kcal/Nm ³)	
Flame length at maximum capacity [mm] (measured from the end of the burner body)	Natural gas (8250 kcal/Nm ³)	3100
	LPG (22500 kcal/Nm ³)	3400
Flame speed at maximum capacity [m/s] (with 20% excess of air)	Medium speed	70
Flame detection	Ionization flame detection electrode or UV cell	
Fuel	Natural gas, LPG	

All information is based on laboratory tests in a neutral pressure chamber. Different conditions and chamber sizes can affect the data.

All information is based on a standard combustor design. Modifications to the combustor will alter performance and pressures.

All data are based on gross calorific values.

All information is based on tests conducted on generally acceptable air and gas piping systems.

Data reported in this technical sheet are subject to change without notice.

Performance data and dimensions are guidelines only and are not binding.

ECOFLAM reserves the right to modify the construction and / or configuration of its products at any time

CHARACTERISTICS OF THE BURNER

Fuel 1: CH₄
 Fuel 1 diaphragm: Ø55

Fuel 2: LPG
 Fuel 2 diaphragm: Ø42

Comburent: Air
 Comburent diap.: 40%

Cone: Ø330

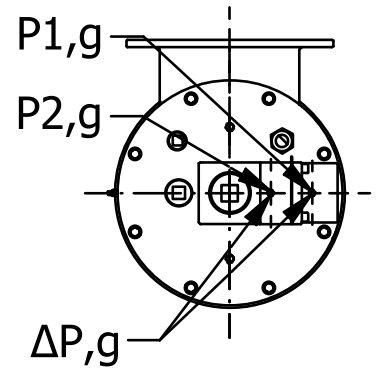
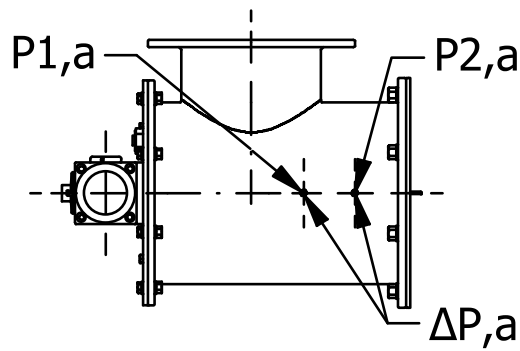

OPERATING RANGE

TYPICAL OPERATING RANGE

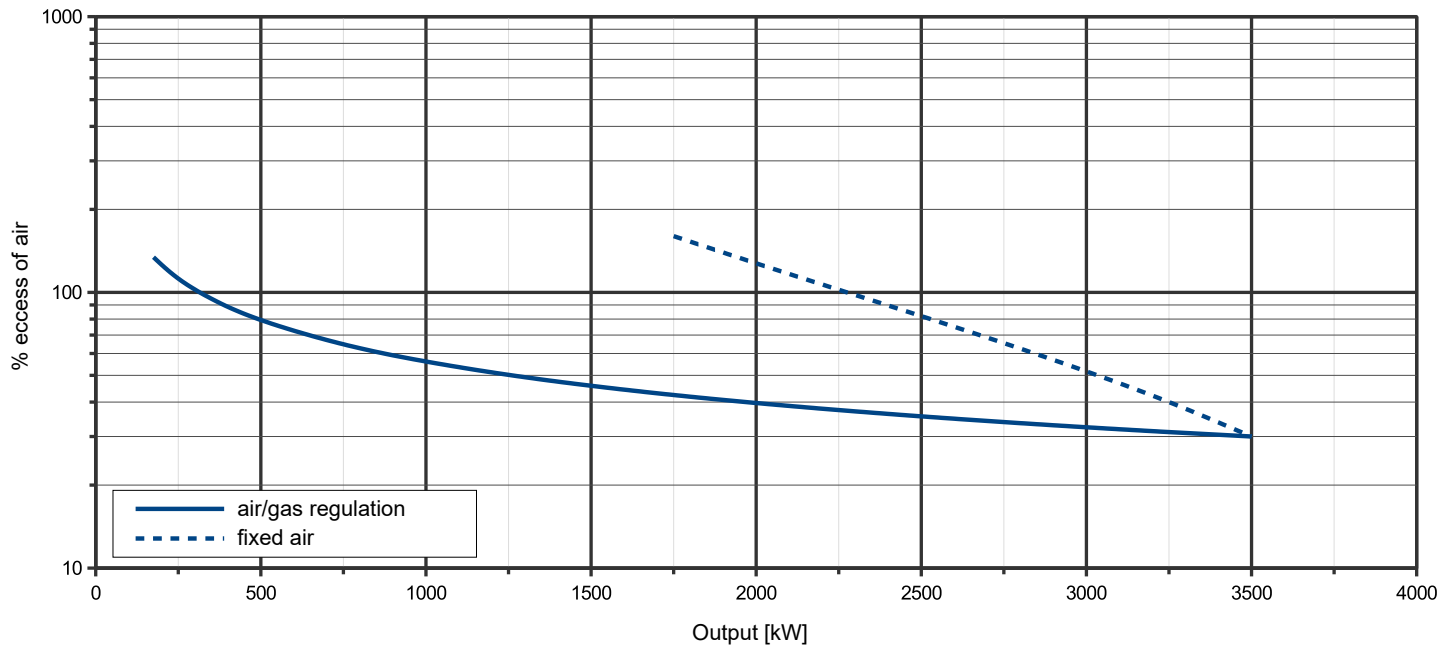

LEGENDA

Q_F Fuel flow
 Q_A Air flow

$P_{1,F}$ Fuel pressure upstream the diaphragm
 $P_{1,A}$ Air pressure upstream the diaphragm
 $P_{2,F}$ Fuel pressure downstream the diaphragm

$P_{2,A}$ Air pressure downstream the diaphragm
 ΔP_F Differential fuel pressure between ports 1 and 2
 ΔP_A Differential air pressure between ports 1 and 2

FLOW RATE CURVES

Q_F [Nm ³ /h]	FUEL			
	$P_{1,F}$ [mbar]		ΔP_F [mbar]	
	Natural gas	LPG	Natural gas	LPG
20	0.38		0.10	
40	0.91		0.22	
60	1.61		0.37	
75	2.25		0.51	
90	2.97		0.66	
105	3.78		0.82	
120	4.69		0.91	
135	5.68		1.04	
150	6.77		1.27	
165	7.95		1.64	
180	9.22		2.10	
195	10.58		2.61	
210	12.03		3.18	
225	13.57		3.79	
240	15.21		4.46	
255	16.93		5.18	
270	18.75		5.95	
285	20.65		6.77	
300	22.65		7.64	
315	24.74		8.57	
330	26.92		9.54	
345	29.19		10.57	
360	31.56		11.65	
375	34.01		12.78	

Q_A [Nm ³ /h]	AIR	
	$P_{1,A}$ [mbar]	ΔP_A [mbar]
600	0.35	0.10
800	0.75	0.21
1000	1.28	0.36
1200	1.96	0.55
1400	2.77	0.77
1600	3.72	1.03
1800	4.81	1.33
2000	6.04	1.67
2200	7.41	2.04
2400	8.92	2.45
2600	10.57	2.90
2800	12.35	3.39
3000	14.28	3.92
3200	16.34	4.48
3400	18.55	5.08
3600	20.89	5.72
3800	23.37	6.40
4000	25.99	7.12
4200	28.75	7.87
4400	31.65	8.66
4500	33.15	9.07
4600	34.68	9.49
4700	36.26	9.92
4800	37.86	10.36

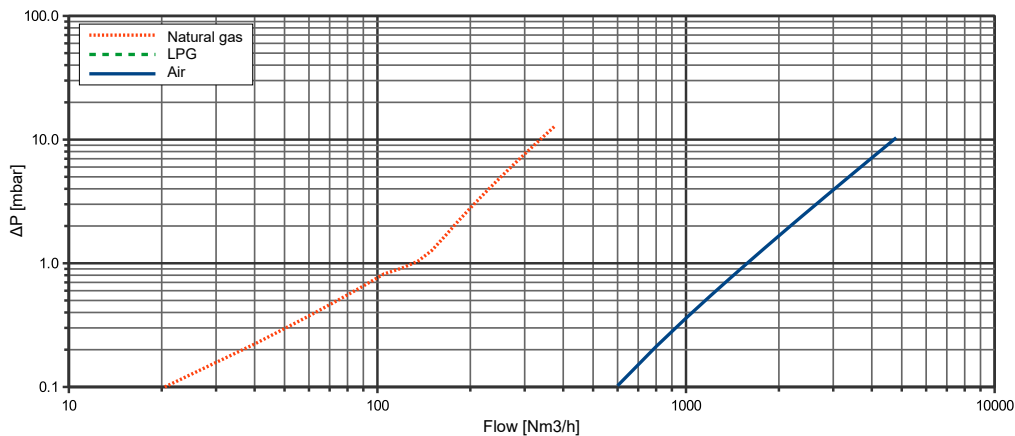

STATIC PRESSURE REQUIRED

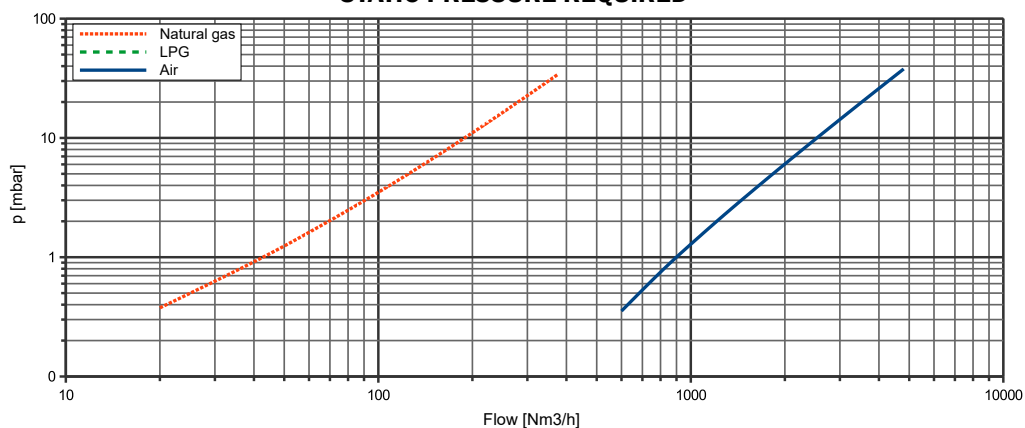

DIMENSIONS [mm]

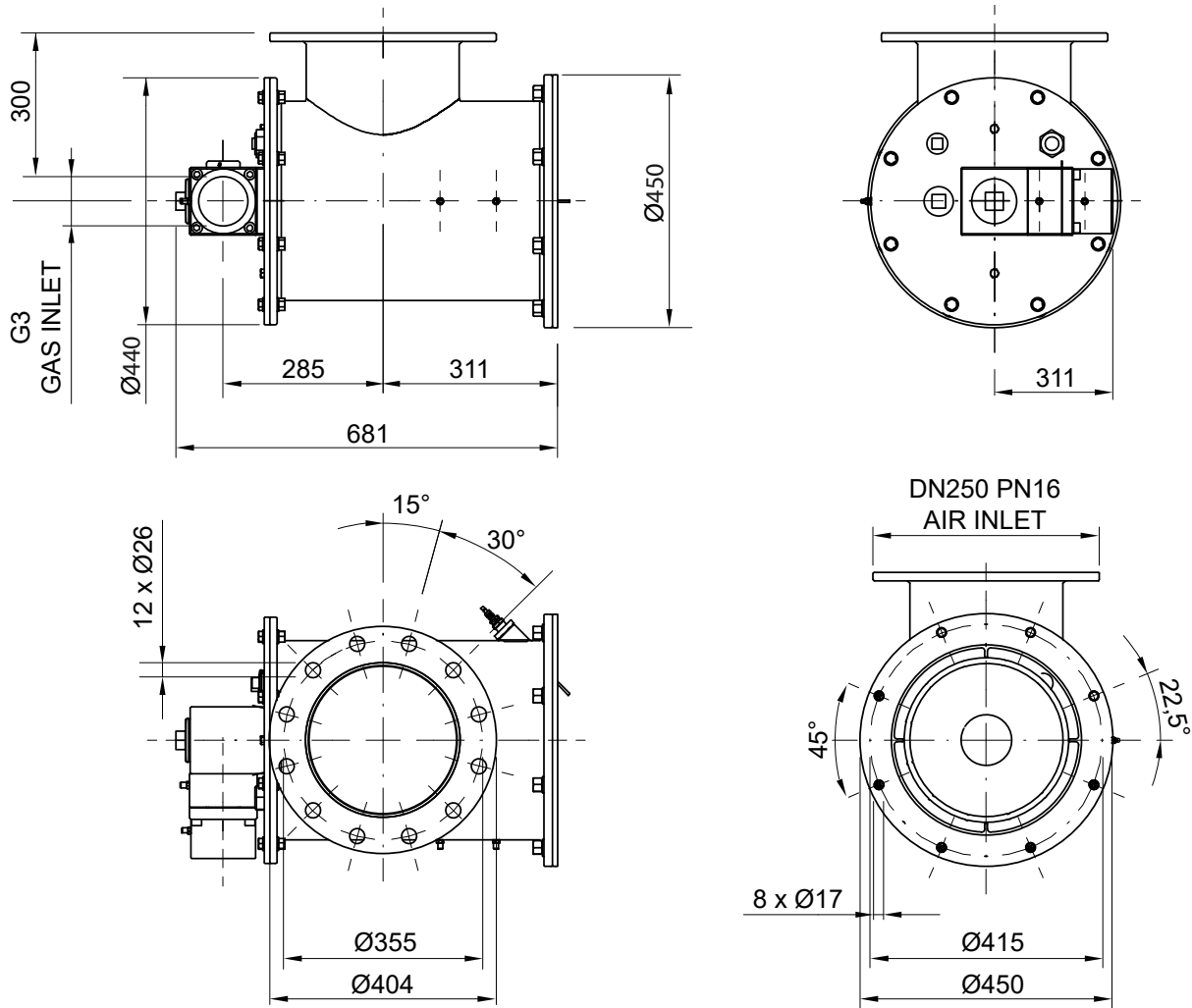

Concrete casting cone:

