

MVRT 140

METALLIC VOLUMETRIC FOR RADIANT TUBE

MVRT 140		
Maximum output [kW]		140
Minimum Power (air/gas modulating) [kW]		14
Fuel pressure at maximum power [mbar] (measured at tapping P _{1F} – pag. 2)	Natural gas (8250 kcal/Nm ³)	55
	LPG (22500 kcal/Nm ³)	130
Air inlet pressure at maximum power [mbar] (measured at tapping P _{1A} – pag. 2)	Natural gas (8250 kcal/Nm ³)	14
	LPG (22500 kcal/Nm ³)	
Flame length at maximum power [mm] (measured from the end of the burner body)	Natural gas (8250 kcal/Nm ³)	700
	LPG (22500 kcal/Nm ³)	
Flame speed at maximum power [m/s] (with 20% excess of air)	Medium speed	70
Flame detection	Ionization probe or UV cell	
Fuel	Natural Gas. LPG or other gaseous fuel upon request.	

All information is based on laboratory tests in a neutral pressure chamber. Different conditions and chamber sizes can affect the data.

All information is based on a standard combustor design. Modifications to the combustor will alter performance and pressures.

All data are based on gross calorific values.

All the information is based on tests undertaken using air and gas piping of generally acceptable design. Any deviation will affect the accuracy of orifice readings.

The information reported on this document may be subject to change without notice.

The data listed on this paper are purely for informational purposes and not binding.

ECOFLAM reserves the right to change the construction and/or configuration of its products in every moment without being obligated to alter previous supplies.

CHARACTERISTICS OF THE BURNER

Fuel 1: natural gas
 Fuel 1 orifice: $\varnothing 13$

Fuel 2: LPG
 Fuel 2 orifice: $\varnothing 10$

Comburent: air
 Comburent orifice: $\varnothing 78$

Stainless steel cone exit: $\varnothing 72$

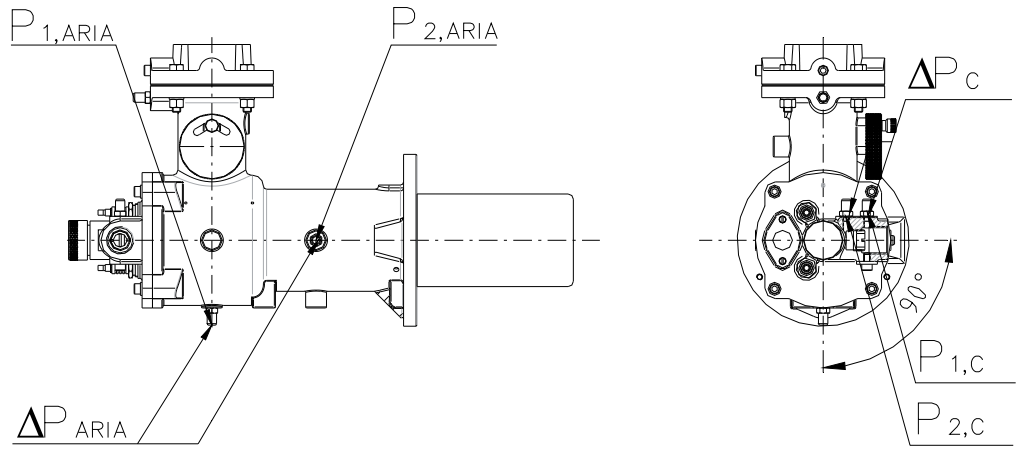

OPERATING RANGE

TYPICAL OPERATING RANGE

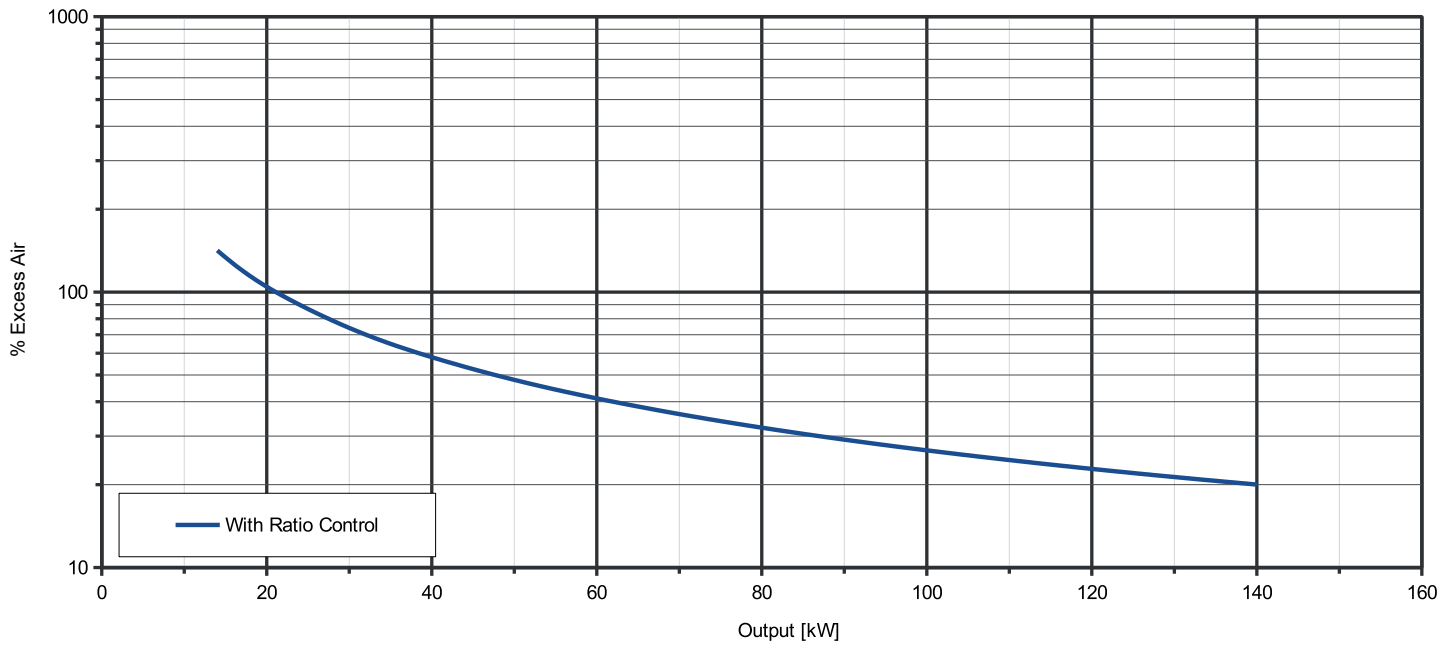

LEGENDA

Q_F Fuel flow
 Q_A Air flow

$P_{1,F}$ Fuel pressure before the diaphragm
 $P_{1,A}$ Air pressure before the diaphragm
 $P_{2,F}$ Fuel pressure after the diaphragm

$P_{2,A}$ Air pressure after the diaphragm
 ΔP_F Differential fuel pressure between tapping 1 and 2
 ΔP_A Differential air pressure between tapping 1 and 2

FLOW RATE CURVES

Q_F [Nm ³ /h]	FUEL			
	$P_{1,F}$ [mbar]		ΔP_F [mbar]	
	Natural gas	LPG	Natural gas	LPG
0.8	0.00	3.25	0.00	0.12
1	0.00	6.86	0.00	0.21
1.5	0.91	11.44	0.04	0.42
2	1.62	20.34	0.08	0.75
3	3.13	40.44	0.17	1.60
4	5.12	67.16	0.30	2.78
5	7.57	100.50	0.47	4.29
5.5	8.98	119.65	0.57	5.16
6	10.50		0.67	
7	13.90		0.92	
8	17.77		1.19	
9	22.11		1.51	
9.5	24.45		1.68	
10	26.92		1.86	
10.5	29.50		2.05	
11	32.20		2.25	
11.5	35.01		2.45	
12	37.95		2.67	
12.5	41.00		2.90	
13	44.17		3.13	
13.5	47.46		3.38	
14	50.86		3.63	
14.5	54.39		3.89	
15	58.03		4.17	

Q_A [Nm ³ /h]	AIR	
	$P_{1,A}$ [mbar]	ΔP_A [mbar]
30	0.47	0.20
40	0.84	0.35
50	1.31	0.55
60	1.88	0.80
70	2.56	1.08
80	3.35	1.41
90	4.23	1.79
95	4.72	1.99
100	5.23	2.21
105	5.76	2.44
110	6.32	2.67
115	6.91	2.92
120	7.53	3.18
125	8.17	3.45
130	8.83	3.73
135	9.53	4.03
140	10.24	4.33
145	10.99	4.65
150	11.76	4.97
155	12.56	5.31
160	13.38	5.66
165	14.23	6.02
170	15.11	6.39
180	16.93	7.16

Δp Vs. Flow Rate Curve

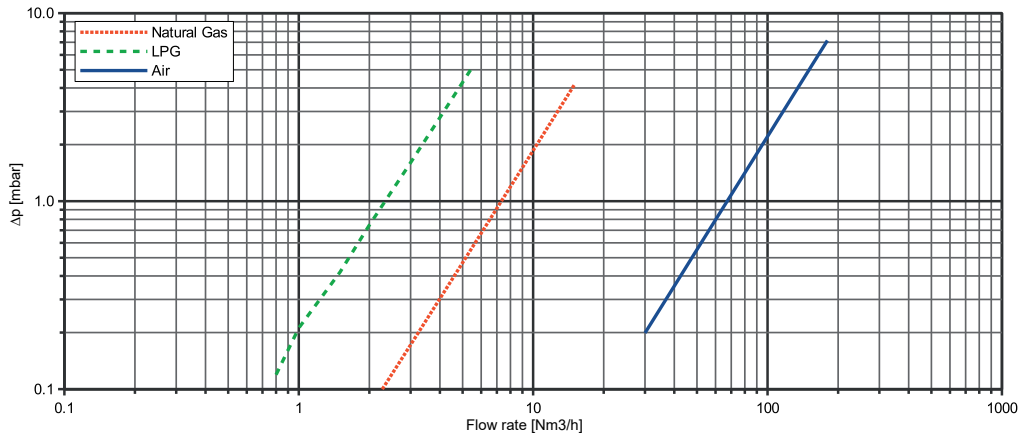

Inlet Static Pressure

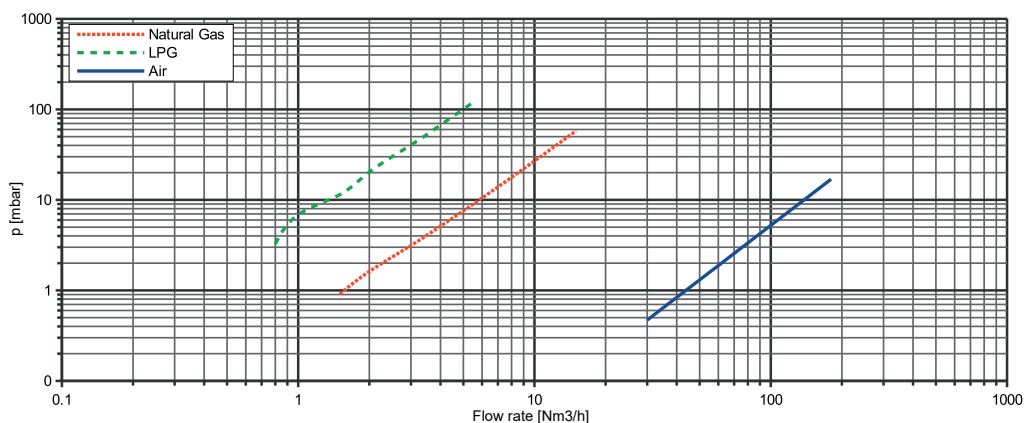

DIMENSIONS [mm]

