

elco

PRODUCT RANGE



OUR COMPANY

Since its foundation in 1928, ELCO has always been a specialist in burners conception and manufacturing. By linking a strong innovative ability to a continued developing drive, ELCO has designed high performing and reliable burners as well as corresponding services throughout the years, and is today one of the leaders in the field of combustion technology.



OUR MISSION

ELCO always looks for the best technologies and continues to develop new ones to improve the efficiency of its solutions.

Our R&D Laboratories are committed to develop innovative technological solutions allowing to:

- optimise the running of the installations lowering costs;
- offer service friendly products easy to maintain;
- preserve the environment lowering acoustic and pollutant emissions.



OUR PRODUCT RANGE

Our proposal provides power, accuracy and reliability in a complete range of burners from 11 kW to 80 MW:



VECTRON
11 - 2300 kW

[Page 4](#)

PROTRON
17 - 550 kW

[Page 5](#)

EK-TRON
320 - 6050 kW

[Page 6](#)

NEXTRON
250 - 11200 kW

[Page 7](#)

EK EVO
250 - 13500 kW

[Page 8](#)

N
1300 - 22000 kW

[Page 10](#)

CUTTING-EDGE BURNERS FOR HEATING AND INDUSTRIAL APPLICATIONS

OUR INNOVATIVE SOUL

The perfect combination of expertise and inventive spirit provides ELCO the drive to constantly improve its product lines and create new ones to meet market demands, in particular those related to the reduction of polluting emissions.

The growing attention to issues related to the environment has led to the development of advanced combustion technologies that allow NOx emissions to be drastically reduced and which use alternative fuels, as happens for example with hydrogen burners, a product of the future that ELCO is already able to offer today.



OUR WORLDWIDE NETWORK

Capitalising on almost 100 years of work experience, ELCO has been capable to build up loyal partnerships and today can count on reliable Partners all over the World.

Combining an instinctively global perspective with a genuinely multicultural approach ELCO today offers you skilled and experienced experts available in more than 70 Countries.

- 3 production plants
- 6 commercial branches
- Strong commercial presence through a network of reliable dealers and partners



HO-/GHO-TRON
68 - 17000 kW

Page 11

EK-DUO
600 - 16000 kW

Page 12

D-TRON
230 - 42000 kW

Page 13

RPD
500 - 80000 kW

Page 14

RPD N
3000 - 80000 kW

Page 15

VECTRON 1...6

MONOBLOCK BURNERS
FROM 11 TO 2300 kW
GAS, LIGHT OIL AND DUAL FUEL



AN OPTIMAL COMBINATION OF EXPERIENCE AND INNOVATION

With its gas, light oil and dual fuel VECTRON burner series, ELCO offers a product range capitalising on more than 90 years of experience in the development of combustion technologies. All VECTRON burners are characterized by ease of installation, adjustment and maintenance, resulting in a product of excellent design.

ENVIRONMENT: PREFER A CLEAN TECHNOLOGY

Thanks to innovative combustion technologies and the experience developed on the field, ELCO is able to offer a Low NOx range able to meet -or exceed- the highest requirements and comply with the European Emission Standards, as well as those of many other countries, such as the ErP Directive. Versions with FGR System able to reach NOx values below 30 mg/kWh are also available starting from the platform VG5.

MAINTENANCE: RAPID AND EASY

In order to grant cost benefits and high performance on all VECTRON models, ELCO implemented features that simplify commissioning and allow quick and efficient burner maintenance. To facilitate maintenance, the combustion parts can be quickly removed, cleaned and, even after being disassembled, reassembly is simple and trouble-free.

COMMUNICATION: AN INTUITIVE AND INTERACTIVE SYSTEM

VECTRON was the first range of ELCO burners to integrate the innovative MDE2 system and ELCOGRAM, a universal language composed of pictograms and numerical data, developed with the aim of providing an interactive interface that is easy to understand and use. This ensures that information is easier to read more than ever before, constantly giving real-time information to engineers during commissioning, operation and at each operation cycle.

RANGE OVERVIEW:



/ GAS RANGE
15 / 2300 kW

/ DUAL FUEL RANGE
35 / 2050 kW

/ LIGHT OIL RANGE
11 / 2080 kW

/ ErP / LOW NOx / ULTRA LOW NOx
up to 1900 kW

V1	ErP									
V2	ErP									
V3	ErP									
V4	ErP									
V5										
V6										
		0	300	600	900	1200	1500	1800	2100	2400 kW

PROTRON 1...3

MONOBLOCK BURNERS
FROM 17 TO 550 kW
GAS AND LIGHT OIL



THE PERFECT CHOICE FOR LIGHT INDUSTRY

The PROTRON range has been specially designed for light industry applications: better heat resistance, compact layout, easy maintenance, integral protective cover, graphic display, are the solutions that characterize these products. PROTRON burners provide high versatility allowing this range to be used in several installations within the process industry: ovens, dryers, spray booths, incinerators, hot air generators.

HIGH VERSATILITY IN ANY SITUATION

The range has been developed in order to fit to any installation requirement. PROTRON burners are available in two different models:

- cubic structure: fully enclosed burner with optimal accessibility and flexibility;
- gun structure: high performance ventilation and maximum compactness.

In addition to this, the maximum flexibility of the range is guaranteed by the wide choice of configurations available for each type of structure.

SOFTWARE PROGRAMMING FOR MAXIMUM FLEXIBILITY

Each burner is configured in the factory by our technicians according to the customer's needs through a series of parameters and options, such as quick start, tightness control, adjustable pre-purge and post-purge, permanent ventilation.

To meet further application requirements, 8 combinations software programming are possible.

RELIABILITY IN ALL CONDITIONS

Reliability is a necessary feature for process industry applications, and the PROTRON range guarantees it in any operating condition, even when at extremely high temperatures.

All PROTRON models have in fact been designed with metal parts that protect the burner in the parts most subject to extreme conditions, ensuring continuity of operation even in the most demanding situations.

RANGE OVERVIEW:



GUN / GAS RANGE
17 / 500 kW

GUN / LIGHT OIL RANGE
18 / 550 kW

CUBIC / GAS RANGE
33 / 210 kW

CUBIC / LIGHT OIL RANGE
30 / 210 kW

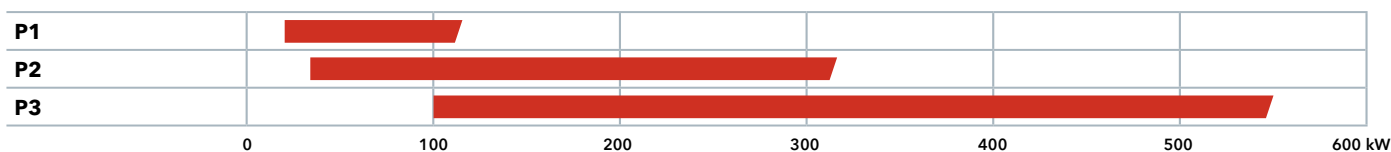

EK-TRON 5...7

MONOBLOCK BURNERS
FROM 320 TO 6050 kW
GAS AND DUAL FUEL

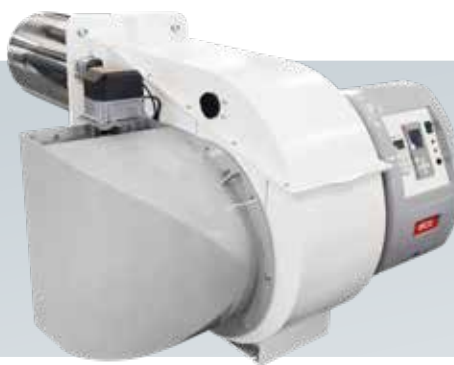

AN UNMATCHED OFFER OF SOLUTIONS

EK-TRON burners are available in a wide range of solutions to meet the NOx levels required by any type of boiler furnaces, even the most narrow ones, and to satisfy the most severe regulations in terms of polluting emissions:

- below 80 NOx mg/Nm³ (Low NOx class 3);
- below 30 or 50 mg/Nm³ at 3% of O₂ without the use of the external recirculation technology;
- below 30 mg/Nm³ with FGR System.

USER-FRIENDLY MAN-MACHINE INTERFACE

ELCOGRAM is a universal language developed by ELCO, based on symbols and numerical data.

This language makes the burner setup and the reading of the information on the burner operation available in real-time through a backlit display with a 5-buttons keyboard. This user-friendly interface assures quick commissioning operations and a total understanding of all the functionality of the burner.

EFFICIENT AND PRACTICAL OPERATION WITH ELECTRONIC CONTROL

All EK-TRON models are fully electronically controlled and they are equipped with the exclusive ELCO man-machine interface allowing simple and effective programming operations.

This results in smooth and performing operation and a quick and simple interaction between the user and the burner.

SIMPLE AND TIME-SAVING MAINTENANCE

The EK-TRON burners have been designed keeping in mind the comfort of the end user.

Maintenance operations can be carried out keeping the original setup of the combustion components. A wide opening above the housing allows easy access to all the components up to the fan.

In this way, maintenance operations are quick and time-saving, and efficient and reliable combustion is granted on the EK-TRON range year after year.

RANGE OVERVIEW:



/ GAS RANGE
340 / 6050 kW

/ DUAL FUEL RANGE
320 / 3900 kW

/ LOW NOx / ULTRA LOW NOx
up to 5800 kW

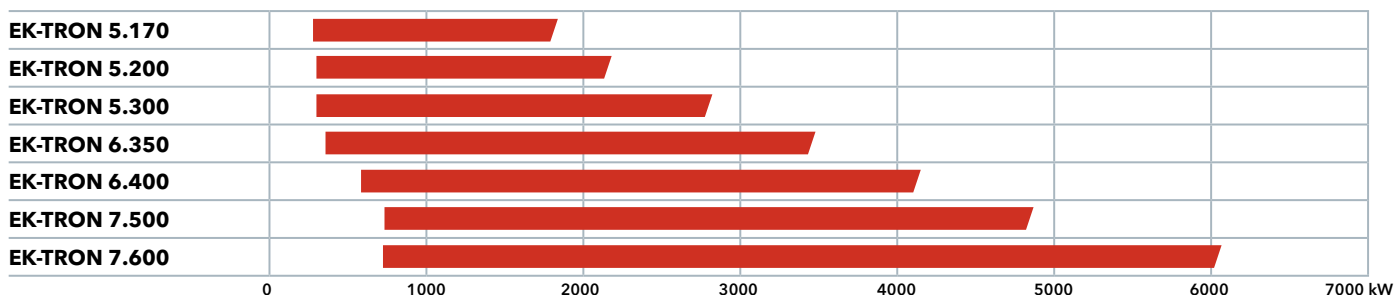

NEXTRON 6...9

MONOBLOCK BURNERS
FROM 250 TO 11200 kW
 GAS, LIGHT OIL AND DUAL FUEL



SMOOTH AND INTEGRAL DESIGN

The original and recognizable design of the NEXTRON® range is the result of a successful integration between the burner and ELCO technologies. NEXTRON® burners are able to perfectly integrate themselves in any installation and professionals will appreciate the innovative construction that makes these burners maintenance simple and time-saving.

HIGH ACOUSTIC COMFORT

The NEXTRON® burner range offers a high acoustic comfort thanks to the integration of the Low Noise System. The unique air intake channel is carefully designed to achieve an acoustic level significantly lower than 80 dB(A) on burners capable to reach power output above 10 MW. This integrated and patented system is definitely a good replacement of the traditional bulky and expensive sound proofing box.

UNIQUE LOW NO_x PERFORMANCE

Developed and improved by ELCO R&D department, the Free Flame and the Diamond Head technologies are unique combustion processes; the new Blue Triple Head allows you to reach even lower NO_x levels, guaranteeing values below 60 mg/kWh. These ELCO technologies are capable to reach the NO_x levels required by the most severe standards for all types of combustion chambers, whether they are 3-pass or reverse pass boilers.

MODULAR SWITCH CABINET BUILT-IN

All the NEXTRON® burners feature integrated switch cabinet and the ISC System provides a modular concept for control devices and accessories: adjusting and safety control box, EMC protected power circuit of fan motor, display with command keyboard within the front of the panel. The ISC System houses also options and accessories, such as the power regulator and the frequency inverter Variation.

RANGE OVERVIEW:



/ GAS RANGE
340 / 11200 kW

/ DUAL FUEL RANGE
250 / 10620 kW

/ LIGHT OIL RANGE
360 / 10620 kW

/ LOW NO_x / ULTRA LOW NO_x
up to 10200 kW

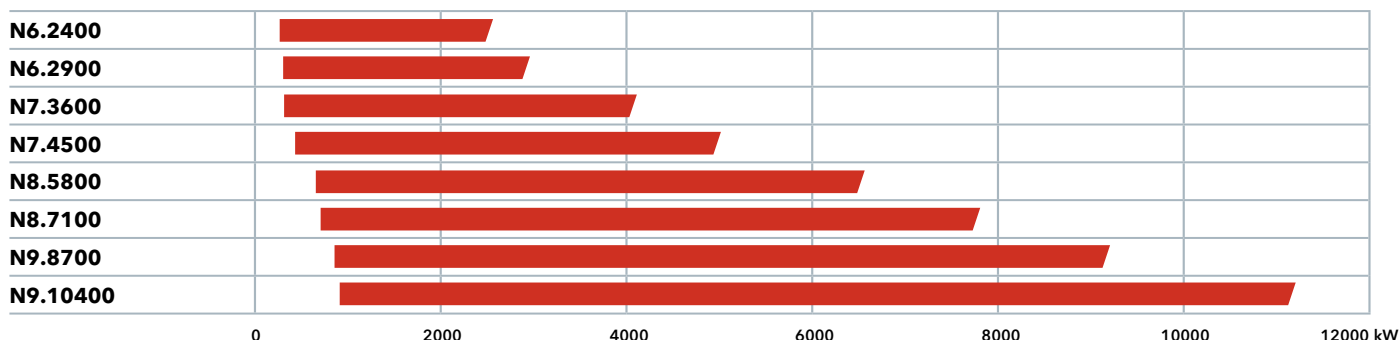

EK EVO 4 / 5

MONOBLOCK BURNERS
FROM 260 TO 1450 kW
 LIGHT OIL



ROBUST AND RELIABLE DESIGN

The structure of the EK EVO 4 and 5 is characterized by an essential e simple design, developed to meet the needs of any heating application and industrial process. This range has been specifically designed to adapt to any condition, combining resistant and reliable materials with extreme ease of use and great comfort during the daily operation.

FLEXIBILITY AND VERSATILITY

EK EVO 4 and 5 are characterized by a high flexibility of installation and operation. The easily adjustable sliding combustion head with dedicated servomotor guarantees high adaptability to varying boiler situations and required emission level. The simple and intuitive switch cabinet allows to easily meet the majority of the application requirements: burner control, power regulator and all other options can be installed on the switch cabinet thanks to a modular concept design.

EFFICIENT AND PRACTICAL OPERATIONS

All EK EVO models are fully electronically controlled and equipped with the highly appreciated ELCO man-machine interface, allowing simple and effective programming operations. This results in smooth and performing operation and a quick and simple interaction between the user and the burner.

ULTRA LOW NOx COMBUSTION HEAD

EK EVO 4 and 5 are two stage progressive/modulating forced draught burners, working with light oil and equipped with low emission combustion technology, that makes these burner series able to outperform the most rigid regulation in terms of pollutant emissions. The Ultra Low NOx combustion head of this range provides flame stability, excellent performance and NOx emissions below 80 mg/kWh, well below the limit of 120 mg/kWh imposed by the EN267/2020 Directive.

RANGE OVERVIEW:



/ LIGHT OIL RANGE / ULTRA LOW NOx
 260 / 1450 kW

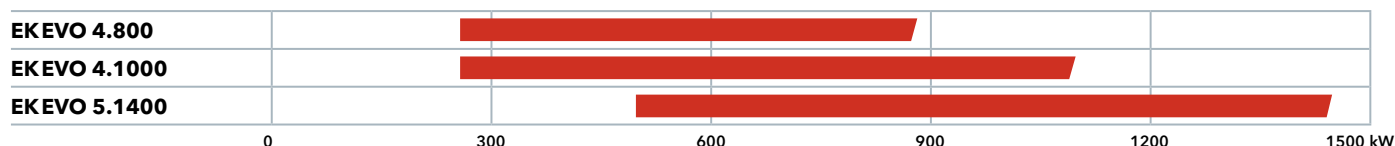

NOx EMISSIONS:

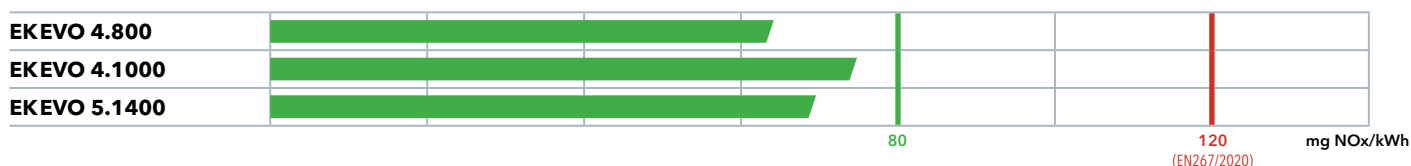

EK EVO 6...9

MONOBLOCK BURNERS
FROM 250 TO 13500 kW
 GAS, LIGHT OIL AND DUAL FUEL



ROBUST AND WELL ENGINEERED DESIGN

The design of EK EVO is the result of a successful synergy between the key features of ELCO technologies and an essential design, also achieved thanks to the introduction of a brand new aluminum machine structure. Professionals will appreciate the flexibility of a 180° orientable air inlet, the compact switch box and the easy to clean glossy paint.

SMART SOLUTIONS FOR EASY MAINTENANCE

The maintenance of the EKEVO burners can comfortably be carried out thanks to a wide opening above the housing, allowing easy access to the combustion components, and thanks to the choice of the material: aluminium, lightweight to handle and resistant at the same time. Maintenance operations are possible without affecting the adjustment of the burner head.

A TOTAL ADVANTAGE IN TERMS OF FLEXIBILITY AND EASE OF USE

The EKEVO burners are characterized by their extreme flexibility of installation; they have been designed to be installed in different ways: up-firing, down-firing, upside-down or side-to-side (twin chamber boilers). All EKEVO models are fully electronically controlled and equipped with the exclusive ELCO interface, allowing simple and effective communication between burner and technician.

ULTRA LOW NO_x VERSIONS WITH AND WITHOUT FGR SYSTEM

ELCO implements the internal and external flue gas recirculation technology to reduce pollutant emissions and satisfy even the most stringent regulations. This technology allows ELCO to guarantee emissions well below 60 mg/kWh with its EK EVO class 4 models equipped with the new Blue Triple Head, and below 30 mg/kWh with the implementation of the FGR System.

RANGE OVERVIEW:



/ GAS RANGE
340 / 13500 kW

/ DUAL FUEL RANGE
250 / 10620 kW

/ LIGHT OIL RANGE
360 / 10620 kW

/ LOW NO_x / ULTRA LOW NO_x
up to 13500 kW

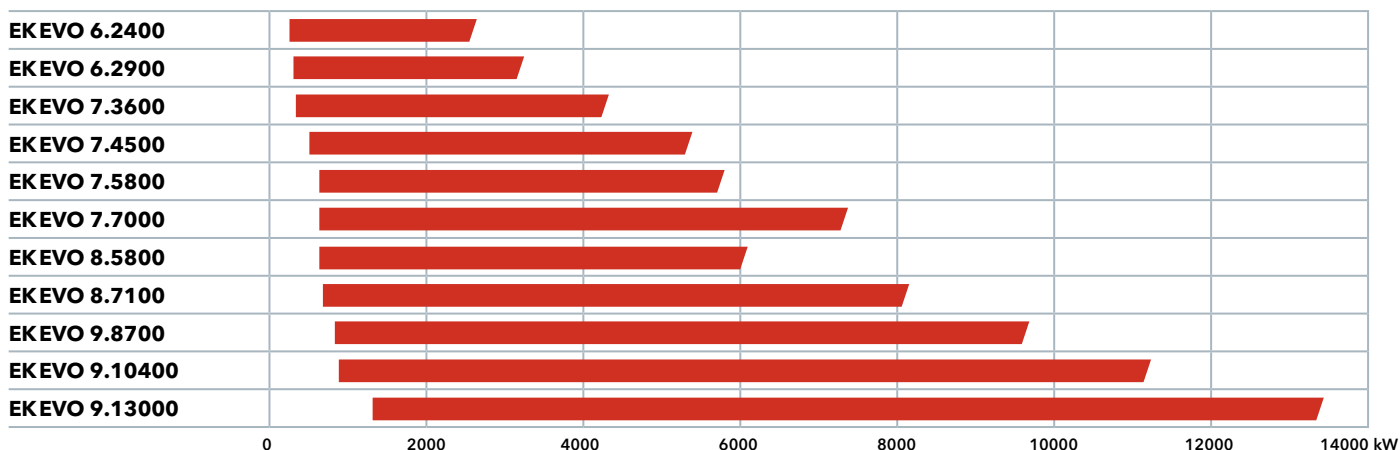

N 10 / 11

MONOBLOCK BURNERS
FROM 1300 TO 22000 kW
GAS, LIGHT OIL AND DUAL FUEL



HIGH POWER AND EASE OF USE

Where a compact solution is needed, a monoblock burner offers advantages over individual components. However, above a power output of 10 MW, the conventional burner becomes too heavy: handling during installation and maintenance works is affected, the strain on the boiler door is too high.

The N burners solve this problem with innovative and weight-saving technology. The key feature is the physical division of the burner into a support frame and a separate air-routing housing.

SIMPLIFIED STRUCTURE TO IMPROVE USABILITY

The burner head and housing have been almost completely separated to allow enough space to easily remove the combustion components. The air pipe between the housing and the burner head is simply closed by a removable cover. It is no longer necessary to pivot the entire burner body to one side or the other.

A further advantage is the possibility of fixing the frame to the ground, depending on the application, thus relieving the boiler door from any mechanical stress.

ULTRA LOW NOx TECHNOLOGY, UP TO 22 MW

Thanks to the introduction of the N11 platform and the innovative solutions of this range, ELCO is able to provide high performance and ease of use on its monoblock range up to 22 MW.

Models capable of guaranteeing NOx emissions well below 60 mg/kWh and 30 mg/kWh with the implementation of the FGR System are available to satisfy any installation requirement.

ADVANCED DESIGN FOR LOW NOISE LEVELS

Particular attention was paid to the design of the fan. The burner sound level meets industry standards, providing a more comfortable working environment.

The two main characteristics that limit the noise emitted by a fan are a high and constant static pressure and the use of a wheel with rear facing blades. The result is stable combustion and reduced noise at the air inlet.

RANGE OVERVIEW:



/ GAS RANGE
1300 / 22000 kW

/ DUAL FUEL RANGE
1300 / 22000 kW

/ LIGHT OIL RANGE
3000 / 22000 kW

/ LOW NOx / ULTRA LOW NOx
up to 22000 kW

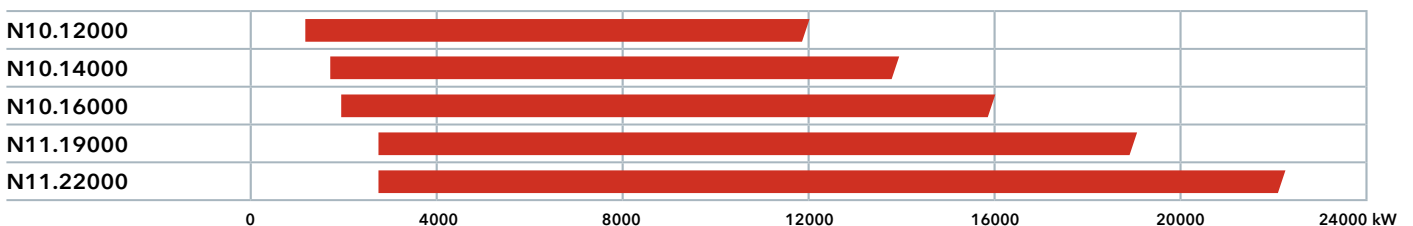

HO-TRON 0...7 / GHO-TRON 3...7

MONOBLOCK BURNERS
FROM 68 TO 17000 kW
HEAVY OIL AND DUAL FUEL
(GAS/HEAVY OIL)



HEAVY OIL BURNERS UP TO 17 MW

ELCO offers a wide range of burners suitable to work with heavy oil (or in dual fuel operation, gas/heavy oil) designed for traditional applications and industrial process applications.

The HO-TRON and GHO-TRON series include several models available in different configurations with a power output covering a range up to 17 MW.

All burners are suitable to work with heavy oil up to 50°C at 50°C.

BURNER VERSIONS TO SUIT ANY NEED

In order to optimize the performance and the ease of use, the HO-TRON and GHO-TRON burners are available in the following versions:

- one stage for HO-TRON 0 and HO-TRON 1 models (up to 340 kW);
- two stages, up to HO-TRON 4 and GHO-TRON 3 models;
- two stage progressive mechanical operation and, on request, also with electrical configuration, for all models up to 17 MW.

EASY MAINTENANCE SOLUTIONS

All models feature easy access to the combustion component in order to simplify the maintenance operations.

The maintenance activities are simplified also thanks to the sliding bar system, which allows easy access to the combustion components, available on all models up to HO-TRON 6.

FLEXIBILITY AND CUSTOMIZATION

All burners are fitted with heavy oil electric heating system on board and integrated electrical panel complete with pre-heater management system.

Ring system components for oil preparation can be designed and supply on request.

For a large extent of applications customized solutions can be offered in order to meet plants requirements.

RANGE OVERVIEW:



/ HEAVY OIL RANGE
68 / 17000 kW



/ DUAL FUEL (GAS/HEAVY OIL) RANGE
414 / 17000 kW

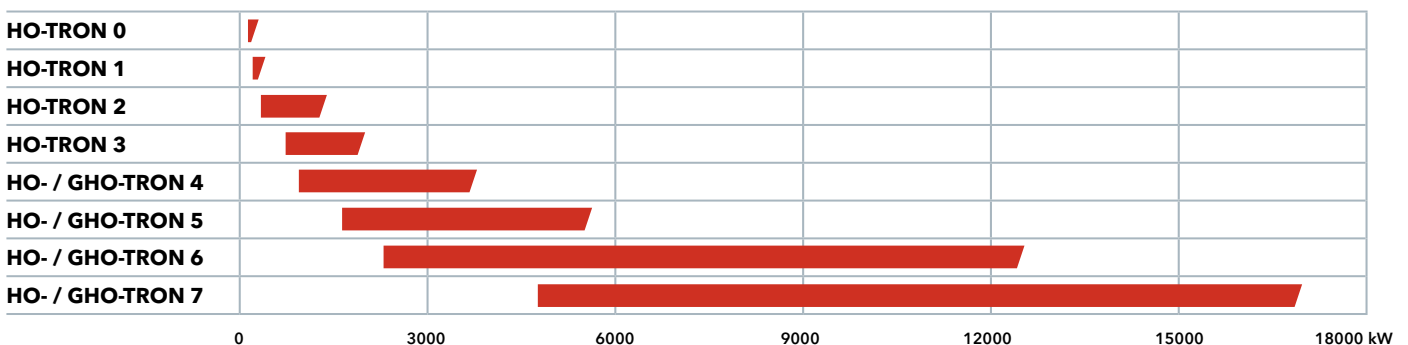

EK-DUO 2...4

DUOBLOCK BURNERS
FROM 600 TO 16000 kW
GAS, LIGHT OIL AND DUAL FUEL



ALL THE BENEFITS OF THE SEPARATE VENTILATION

In contrast to monoblock burners, duoblock burners are made up of two units, or blocks, as the name implies: the burner head with the air inlet, and the separately-installed fan; the two units are connected via an air duct.

The separate installation of the fan offers several benefits:

- the fan can be installed in a separate room, for instance in the cellar; this results in considerably lower noise levels in the boiler room; when the fan is installed in the same room, a fan enclosure can be used to achieve optimum sound absorption, without inhibiting access to the burner;
- less space required in front of the boiler and in the combustion chamber;
- individual fan layout with optimum adaptation of the fan characteristic curve to suit the pressure ratio of the heat generator; this guarantees pulsation-free and stable burner behaviour, even on heat generators with high resistance on the exhaust side;
- combustion air can be pre-heated to increase installation efficiency;
- lower weight loading on the boiler front.

HIGH PERFORMANCE BURNERS IN DUOBLOCK CONFIGURATION

The EK-DUO models are high-performance burners offering well-engineered duoblock technology at an affordable price.

These burners are predominantly used to burn standard fuels (i.e. domestic light oil and natural gas), and represent a perfect choice for shell boilers, water tube boilers and thermal oil boilers.

The separate fan installation of the burner allows to overcome high combustion chamber resistance and provide the customer with a high level of comfort of use thanks to the characteristics of this type of installation.

CLEAN COMBUSTION WITH NO COMPROMISE ON PERFORMANCE

The EK-DUO range is equipped with combustion heads and technical solutions to provide the perfect balance between high performance and maximum attention to the emissions produced by the burner.

The tried-and-tested Diamond burner head for gas models and the Free Flame burner head for oil and dual fuel versions grant high performance and low emissions, meeting the most stringent Low NOx requirements.

The FGR System provide further options to reduce the emissions, reaching NOx values below 30 mg/kWh. The fuel-air mixture is adjusted solely using a modern electronic compound controller.

RANGE OVERVIEW:



D-TRON 2...9

DUOBLOCK BURNERS
FROM 230 TO 42000 kW
 GAS, LIGHT OIL, HEAVY OIL AND DUAL FUEL



EFFICIENCY AND FLEXIBILITY UP TO 42 MW

D-TRON range includes duoblock burners available in a range of powers from 340 kW to 42 MW. These burners are suitable to work with any type of fuel: standard versions are available in gas, light oil, heavy oil and dual fuel operation; all models can also be configured to work with alternative fuels and to satisfy any technical requirement of the customer. D-TRON burners can run in standard configuration with air up to 60°C; versions suitable to work with pre-heated combustion air up to 200°C can be used in order to achieve higher efficiency values.

LOW NO_x AND ULTRA LOW NO_x VERSIONS

All D-TRON in gas and dual fuel (gas/light oil) operation are available in Low NO_x class 3 and in class 2 configuration, in order to provide the customer with a choice that is perfectly suited to the requirements of his installation. These burners also offer the opportunity to be fitted with the FGR System in order to reach NO_x emissions below 30 mg/kWh and comply even with the most stringent regulations.

HIGHLY CUSTOMIZABLE SOLUTIONS TO SUIT ANY APPLICATION

Thanks to a wide range of models up to 42 MW and their extreme flexibility and ease of use, the D-TRON burners ensure high compatibility with any type of installation. Burners can be assembled with air duct connection in different layouts in order to meet a wide range of specifications in terms of performance and overall dimensions. Terminal block configuration is provided as standard; versions with integrated control panel are available on request.

LOW MAINTENANCE, HIGH RELIABILITY

All D-TRON models feature easy maintenance. Access to the combustion head and to the internal components is allowed from the housing top cover with a single operation, without removing the burner from the boiler. The clear layout allows rapid cleaning of the mechanical components, keeping the installation always in good conditions.

RANGE OVERVIEW:

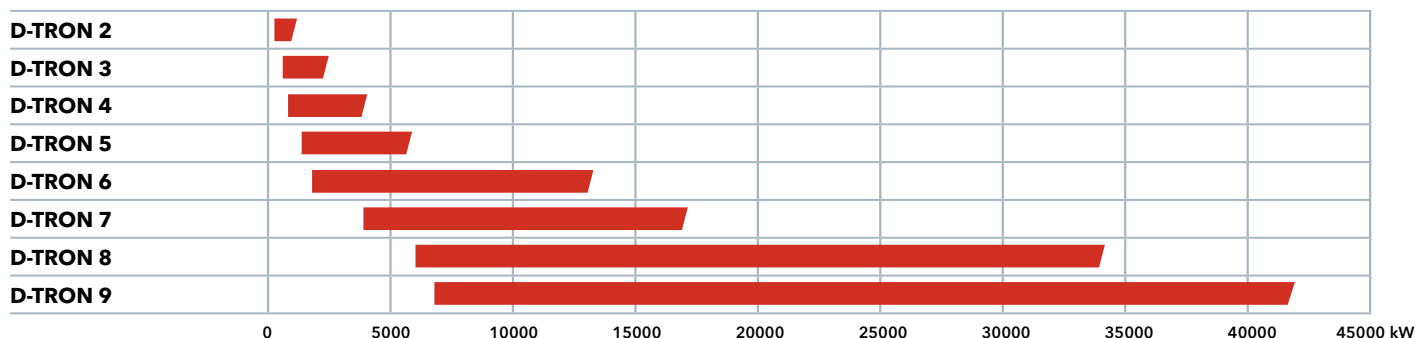

RPD 20...160

DUOBLOCK BURNERS
FROM 500 TO 80000 kW
 GAS, LIGHT OIL, HEAVY OIL AND DUAL FUEL



THE PINNACLE OF ELCO BURNER TECHNOLOGY IN A RANGE UP TO 80 MW

The RPD range offers high power duoblock burners up to 80 MW which represent the pinnacle of the technology of the ELCO industrial range.

Thanks to their extreme flexibility, RPD burners are suitable for almost any firing-related task.

All RPD models are fitted with adjustable air deflector plates, which can be used to swirl the combustion air.

The flame configuration can hereby be directly influenced according to the geometry of the combustion chamber.

The combustion head features optimised internal geometry to reduce head loss and the power demand of the fan motor.

ADVANCED TECHNOLOGIES, LOW EMISSIONS AND FUTURE-READY SOLUTIONS

The extreme versatility of the RPD range also derives from the availability of models suitable to work with any type of fuel or combination of fuels.

In addition to traditional fuels, such as gas, light oil or heavy oil, the burners of this series are highly configurable in order to also adapt to work with alternative fuels, and in particular with hydrogen, thanks to the experience that ELCO has developed over the last few decades in the study of technologies suitable for this type of fuel.

The Low NO_x versions and the application of the FGR System allow to reduce polluting emissions, making this range of burners an excellent choice also in terms of environmental sustainability.

MAXIMUM FLEXIBILITY FOR HIGHLY CUSTOMIZED SOLUTIONS

This range of burners is able to fulfill high capacity and high turndown needs and allows installation in very high pressurized combustion chambers.

Burner control regulation may be designed in accordance with the task and is, where possible, implemented via digital combustion manager as well as an electronic compound for a precise fuel-air ratio. For simpler tasks, mechanical compound systems are also available.

All RPD models can work with pre-heated combustion air up to 200°C and can be used in order to achieve greater values of efficiency.

CUTTING-EDGE BURNERS TO MEET ANY CUSTOMER REQUIREMENT

The flexible and modular design of the RPD range, combined to the fact that it is based on a wide range of solutions that have proved effective in practice, makes this burners suitable to be used in all those cases where complex tasks and high technical requirements demand customised heating installation solutions.

Typical examples of use include:

- use with multiple gases and/or multiple liquid fuels, simultaneously;
- applications where the use of special fuels is required, such as hydrogen
- water tube boilers used in big heating installations and industrial processes with a remarkable thermal demand;
- refinery processes and chemical industry applications;
- waste incineration plants.

RANGE OVERVIEW:

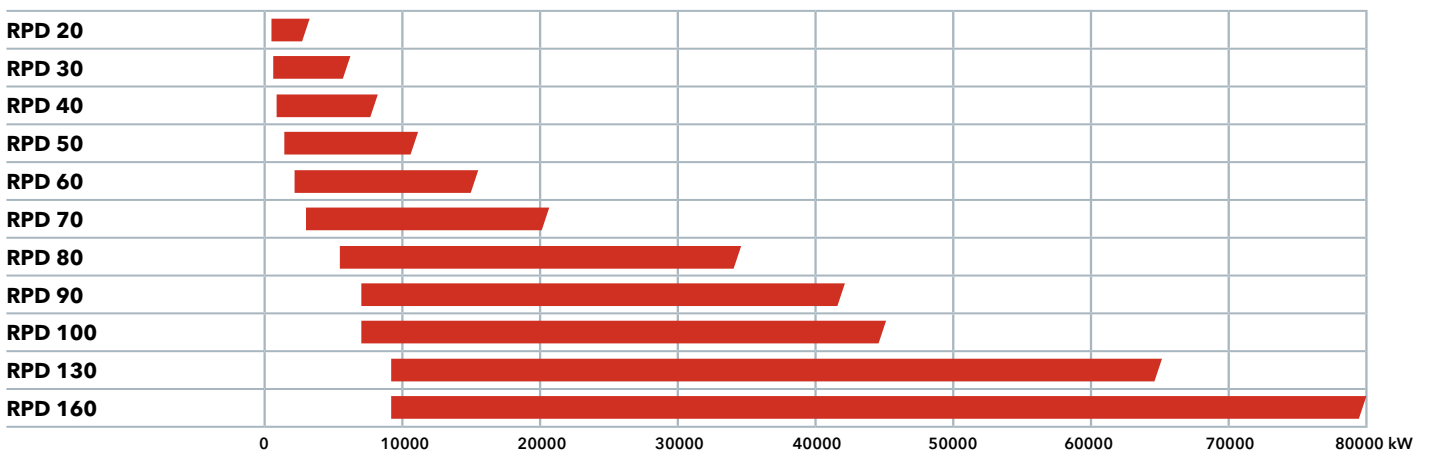

RPD N 70...160

DUOBLOCK BURNERS
FROM 3000 TO 80000 kW
GAS



IMPROVED AND OPTIMIZED BURNER CONCEPT

The RPD N range is an evolution of the successful RPD duoblock series.

The flexible and modular design of the range has been improved in almost any area, from the burner housing design to the combustion head.

The result is a range of products from 3 to 80 MW suitable for an extremely wide range of applications, especially in all those cases where complex tasks and high technical requirements demand customised heating installation solutions.

LOW NO_x AND ULTRA LOW NO_x CONFIGURATIONS

RPD N burners are available with different combustion heads to provide a perfect match between burner performance and required NO_x emission level:

- models equipped with U1 and U2 combustion heads are Low NO_x Class 3 according to the EN676 Standard (NO_x<80 mg/Nm³);
- the new FX Blue Triple head reaches NO_x values far below 50 mg/Nm³ thanks to the new head configuration;
- for installations requiring even lower emission values, the RPD N burners can be equipped with the FGR System, which allows to operate below 30 mg/Nm³

SIMPLIFIED AND HARMONIZED BURNER STRUCTURE

The housing of the burner has been harmonized to reduce the product complexity, reduce the weight of the burner and improve the setting during the commissioning.

The air flap system has been redesigned and now includes a lever that allows adjustment of the angle of all flaps, providing a positive impact on the air swirl.

Thanks to the CFD simulation the air flow has been optimized, avoiding turbulence and providing a better distribution of the air. The result is a reduction of the pressure drop and an important contribution to lowering the NO_x emission.

FLEXIBLE AND EASILY ADJUSTABLE COMBUSTION HEAD

In the U1 and U2 versions the head has been redesigned in order to adapt its length to the boiler characteristics: this new concept allows the combustion components to slide and modify the length of the head:

- up to 300 mm for RPD 70 N and 80 N;
 - up to 400 mm for models from RPD 90 N to RPD 160 N.
- Even if the short length is ordered the user can modify the length of the combustion head to the long version.

This enlarged flexibility of head setting allows to fit all the most requested boiler lining depths.

Also the head pull-out slider has been improved to give a perfect alignment of the head with the housing of the burner and ease the maintenance operation.

RANGE OVERVIEW:

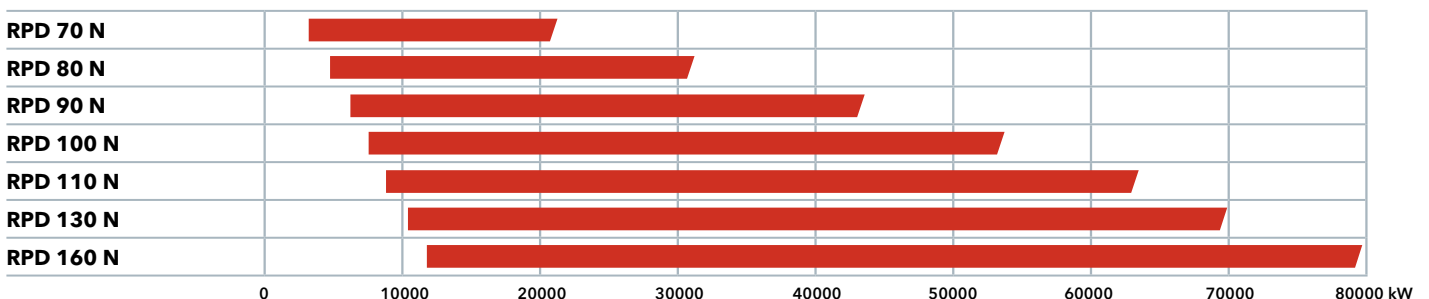

TECHNOLOGIES AND SYSTEMS

To constantly improve its products, ELCO is committed to develop innovative technological solutions allowing to optimise the running of the installations, to ease technicians work, and naturally to preserve the environment. In order to provide quick responses to its market's demands, the range of ELCO burners is entirely conceived around a consistent combination of Systems.

MDE2 SYSTEM

Permanent communication of information easy to use



Equipped with the MDE2 System, the universal language Elcogram and the 5-button keypad, ELCO burners adjust themselves and constantly communicate to the technicians and operators:

- real time information about each ignition and during the running;
- statistical information about the burner operations recorded during the whole year before the maintenance operations.

Elcogram, a universal language

As ELCO products are distributed worldwide, the company has developed a universal language composed of pictograms and numerical data. The pictograms use the majority of the symbols used on the wiring diagrams which are recognised and understood by all Nations. This ensures that information is easier to read than ever before.

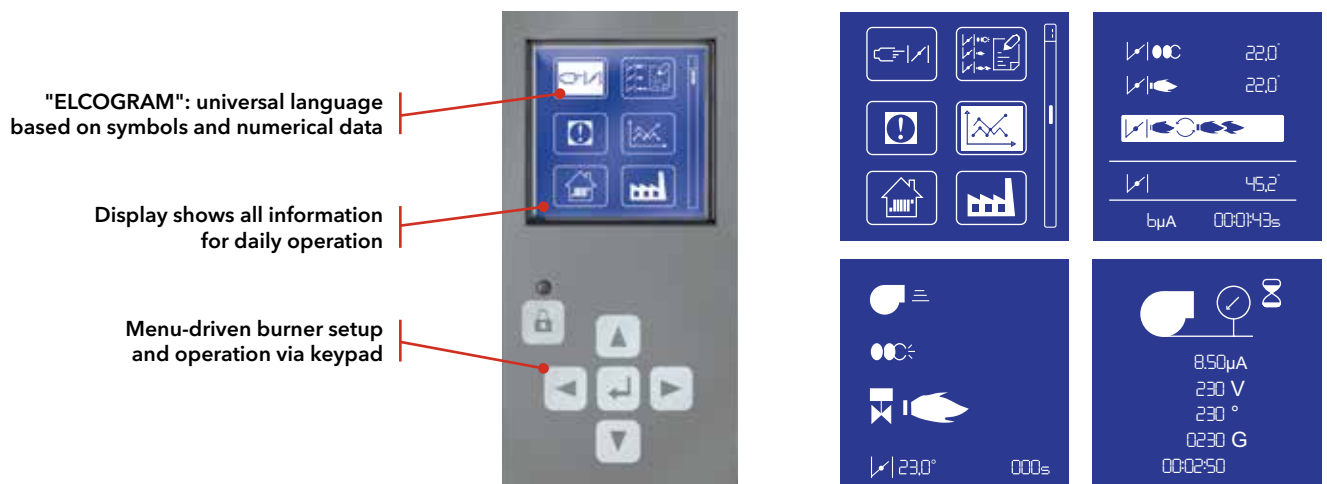

CMS SYSTEM

The evolution of combustion management systems



CMS is a state of the art system for burner management that sets new standards in control automation. The system provides a full combustion management solution that meets all relevant safety standards, and is certified for all main markets and Standards.

CMS system is simple and easily configurable to meet a wide range of application requirements, from low cost to high end solutions, for industrial or residential applications.

The CMS grants efficient communication via BUS and is extremely flexible due to the fact that is fully configurable, fully compatible with external devices/systems and fully scalable, allowing additional functions, such as VSD fan control, oxygen trim and CO control. A wide number of interfaces are available, from low-cost keypad to high-resolution touchscreens, allowing intuitive and easy interaction between user and machine.



TECHNOLOGIES AND SYSTEMS

GEM SYSTEM

Electronic burner control: high safety and low costs



The use of electronic technologies in burner control systems helps to reduce running costs, improve reliability of operation and lower pollutant emissions. The electronic combustion manager used on ELCO burners are responsible not only for the burner control (formerly the task of the traditional automatic combustion control unit) but also for fuel/air regulation. Data stored electronically has replaced the mechanical characteristic curve and help to achieve an unprecedented level of precision in air/fuel ratio regulation across the burner's entire control range, a prerequisite for efficient, energy- and cost-saving operation.

The GEM System controls the position of one or more activators simultaneously.

The servomotors of the air flow and oil components are controlled by a microprocessor which contains set points defined for each load curve. An additional advantage of the GEM is that it provides specific information on all the commands and current situation of the overall system: these can be accessed directly or by remote control.

The digital programming is user-friendly, it is carried out through the display of the MDE2 System or through a PC by using a simple procedure facilitated by easy instructions in a clear language.

VARIATRON

Speed regulation: noise reduction and energy saving



To improve the performance of heating or industrial systems, ELCO applies Variatron (fan speed control).

Conventionally, the air in modulating burners is regulated by an air flap. In the partial load range, a large amount of the air pressure generated by the ventilator goes to waste.

With speed regulation, the speed of the combustion-air fan is varied continuously depending on the burner output required. Full speed is reached only at maximum burner output. In the predominant partial load range, lower speed translates into significant reductions in power consumption and noise emissions.

The Variatron operates in step with the air damper both with the GEM System and with the AGP System, which guarantees a combustion with minimum air excess by continuously monitoring all operating conditions.

Application of the Variatron to ELCO burners results in:

- electrical consumption savings in the order of 50%;
- turndown ratio of up to 1:10, resulting in perfect adaptation to system requirements and improvement in average seasonal efficiency, in particular with condensing or low-temperature boilers or specific processes;
- silent start-up and average overall noise reduction between 2 dB(A) (at maximum power) and 12 dB(A) (at minimum power).

RTC SYSTEM

Rapid and easy maintenance solutions



The functional housing design of all ELCO burners, combined with the innovative combustion head technologies, creates the RTC System (Retained Head Adjustment) and provides the user with several advantages:

- full access to all components, by simply removing the upper cover;
- complete removal of the combustion head and access to its internal components with a single operation, without removing the burner from the boiler or disconnecting the gas train;
- maintenance of the adjustments made to the combustion head, which are not changed during service operations;
- quick cleaning of mechanical components, thanks to their optimized arrangement;
- reduced servicing times through the use of standard nuts, bolts, screws and pipe fittings, which can be adjusted using only a few tools.

The combination of all these technical solutions makes it possible to simplify and speed up all the operations carried out on the burner, reducing downtime and cost of maintenance.

COMBUSTION TECHNOLOGIES

DIAMOND HEAD

Low emissions and reliable operation



The principle of Diamond Head combustion technology is based on the internal recirculation of the combustion flue gases. The gases are partially drawn into the base of the flame via triangular openings placed at the end of the combustion head.

The position and geometry of the gas injectors are such that a significant quantity of combustion flue gas is drawn in and rapidly mixed with air and gas at the root of the flame.

This mixture crosses the main reaction area, slowing the combustion, which resulted in lowering the main flame temperature. The result of this staging combustion is a significant reduction in the formation of thermal nitrogen oxides.



FREE FLAME TECHNOLOGY

The pinnacle of low-polluting burner engineering



The Free Flame combustion technology is based on the internal recirculation of the flue gas, combined with high speed flow of the fuel air mixture. The flame stabilizes at a certain distance from the combustion head, thus leaving space for the mixture of reagents and flue gas.

This phenomenon greatly reduces NO_x emissions. The flame seems to float in the furnace, thus giving the system its name: «Free Flame».



MULTI-STAGE HEAD

Clean emissions and flame stability



The principle of the Multi-Stage combustion head is based on the separation of the flame in multiple areas. The result of this process is a significant reduction of the temperature of the flame and, as a direct consequence of this, a drop of the NO_x emission.

The implementation of this technology does not result only in lowering the pollutant emissions but also assure a very stable flame in all operation conditions.

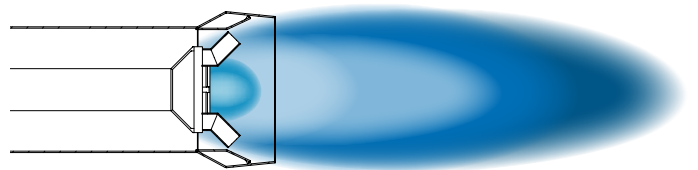

BLUE TRIPLE HEAD

Extreme low NO_x values and high flame stability



The principle of the "Blue Triple Head" is based on a stage combustion combined with an internal recirculation of the combustion flue gases.

Multi-Stage Combustion allows stable nucleus flame and highest internal flue gas recirculation in next stage.

The result is a very low NO_x value, a CO tending to 0 and a high stability that guarantee the limits even in standard combustion chambers.



CUSTOMER CARE

COMMISSIONING, MAINTENANCE AND INSPECTION

For safe and efficient operation of your burner system it is very important that the burner is commissioned by a competent person.

The combustion will be optimally adjusted over the whole power range of the burner, and all the safety devices will be tested.

To keep your installation in good conditions, it is important to maintain the burner periodically.

It is also very important to inspect all the safety devices to ensure that your system operates safely.

Fortunately, you can rely on the professional services of ELCO which can perform this service for you.



RELIABLE SUPPLY OF SPARE PARTS

Spare parts have always had a great importance inside the ELCO world. Considering the high amount of parts involved in every single product, some of these parts might naturally need to be replaced.

ELCO can count on an International network offering original spare parts in order to guarantee the highest quality, reliability and safe continued operation of the appliance.

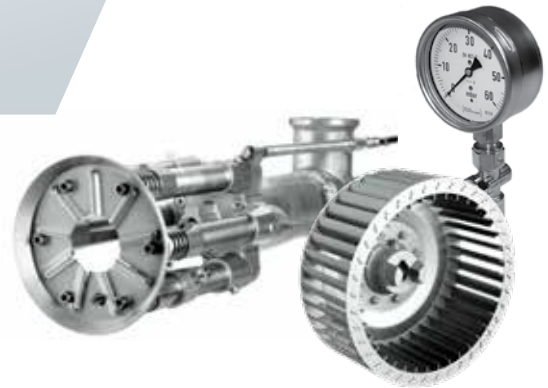

THE BURNER ACADEMY

In order to respond to the needs of our customers we created a Burner Academy, a real training school where the knowledge of our technicians is passed on to our trainees.

We provide the opportunity for boiler room personnel, operators and engineers to attend a series of training sessions carried out on our test bench by highly qualified instructors.

The Burner Academy uses various training locations where boilers are installed and where people can be trained in theory and in practice. We offer courses at different levels and also the possibility to handle all your needs in a customer-specific training.



WORLDWIDE SERVICE NETWORK

In Western Europe, ELCO has a well organised service network. Outside Western Europe ELCO uses a network of partners, consisting of well-trained local engineers, to carry out its service operations.

These technicians are able to perform both commissioning and local service and they do it in a very professional and efficient way.



Subsidiaries ELCO

GERMANY

ELCO GmbH
Dreieichstraße 10
Mörfelden-Walldorf
Tel.: +49 (0) 6105 287-287
Fax: +49 (0) 6105 287-199

NETHERLANDS

Elco Burners B.V.
Meerpaalweg, 1 - 1332 BB Almere
P.O. box 30048 - 1303 AA Almere
Tel. +31 088 69 573 11
Fax +31 088 69 573 90

SWITZERLAND

Elcotherm AG
Sarganserstrasse 100
7324 Vilters
Tel. +41 (0)81 725 25 25
Fax +41 (0)81 723 13 59

AUSTRIA

ELCO Austria GmbH
Aredstraße 16 - 18
2544 Leobersdorf
Tel. +43 (0)2256 639 99 32
Fax +43 (0)2256 644 11

FRANCE

14, rue du Saule Trapu
Parc d'activité du Moulin
91882 Massy
Tel. +33 01 60 13 64 64
Fax +33 01 60 13 64 65

ITALY

Via Roma, 64
31023 Resana (TV)
Tel. +39 0423 719500
Fax +39 0423 719580

UK & IRELAND

Ariston Thermo UK Ltd
Suite 3, The Crown House
Blackpole East, Blackpole Road,
Worcester WR3 8SG
Tel. +44 01905 788010

CHINA

Ariston Heating Solutions (China) Co., Ltd.
25th floor, T1, Shanghai T-Center
No. 1428 Daduhe Road, Putuo District, Shanghai
Tel. +86 21 6039 8691
Fax +86 21 6039 8620

Contact us to know more
about our products and solutions

www.elco-burners.com
contact@elco-burners.com