

elco

EK-TRON

CATALOGUE





EK-TRON

CATALOGUE

THE COMPANY	_____	p. 4
ELCO SYSTEMS AND TECHNOLOGIES	_____	p. 8
RANGE OVERVIEW	_____	p. 12
GAS RANGE	_____	p. 14
DUAL FUEL RANGE	_____	p. 38
GAS TRAINS	_____	p. 46
OPTIONS AND ACCESSORIES	_____	p. 50



CUTTING-EDGE BURNERS FOR HEATING AND INDUSTRIAL APPLICATIONS

OUR COMPANY

Since its foundation in 1928, ELCO has always been a specialist in burners conception and manufacturing. By linking a strong innovative ability to a continued developing drive, ELCO has designed high performing and reliable burners as well as corresponding services throughout the years, and is today one of the leaders in the field of combustion technology.

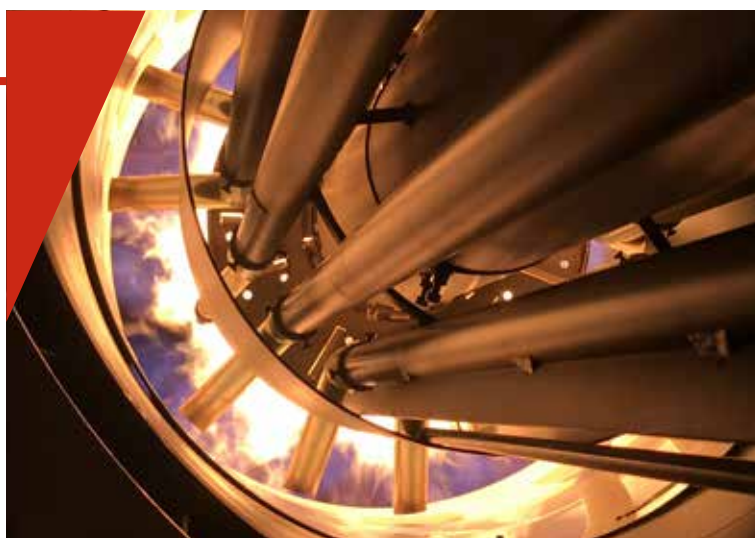

OUR MISSION

ELCO always looks for the best technologies and continues to develop new ones to improve the efficiency of its solutions.

Our R&D Laboratories are committed to develop innovative technological solutions allowing to:

- optimise the running of the installations lowering costs;
- offer service friendly products easy to maintain;
- preserve the environment lowering acoustic and pollutant emissions.



OUR KNOWLEDGE

Your contacts at ELCO and its partners are recognised experts with years of experience. Our worldwide support starts from concept creation to planning, design and project management up to commissioning and on-going operation of the plant throughout its life cycle.

As an ELCO customer, you can count on us for products that guarantee reliability, quality and high performance in any application and working condition.



OUR SERVICE NETWORK

Taking advantage of a staff composed of technicians and engineers with a long experience, ELCO is able to provide professional support to the customer in order to define together the best solution and to develop and manage the project through its entire life-cycle.

ELCO Service activities define the standards in the market and each customer can rely on high performance and reliable products.



OUR INNOVATIVE SOUL

A right mix of experience and spirit of innovation gives ELCO the push to constantly refine its products and develop new ones to respond to market demands, in particular those related to the reduction of polluting emissions.

The growing attention to issues related to the environment has led to the development of advanced combustion technologies that use alternative fuels, as happens for example with hydrogen burners, a product of the future that ELCO is already able to offer today.



TECHNICAL ASSISTANCE

For safe and efficient operation of your burner system it is very important that the burner is commissioned by a competent person. The combustion will be optimally adjusted over the whole power range of the burner, and all the safety devices will be tested.

To keep your installation in good conditions, it is important to maintain the burner periodically. It is also very important to inspect all the safety devices to ensure that your system operates safely.

Fortunately, you can rely on the professional services of ELCO which can perform this service for you.



BURNER ACADEMY

In order to respond to the needs of our customers we created a Burner Academy, a real training school where the knowledge of our technicians is passed on to our trainees.

We provide the opportunity for boiler room personnel, operators and engineers to attend a series of training sessions carried out on our test bench by highly qualified instructors, who hold the courses in English, German, French, Italian and Dutch language.

The Burner Academy uses various training locations where boilers are installed and where people can be trained in theory and in practice. We offer courses at different levels and also the possibility to handle all your needs in a customer-specific training.



RELIABLE SUPPLY OF SPARE PARTS

Spare parts have always had a great importance inside the ELCO world. Considering the high amount of parts involved in every single product, some of these parts might naturally need to be replaced. ELCO can count on an International network offering original spare parts in order to guarantee the highest quality, reliability and safe continued operation of the appliance.

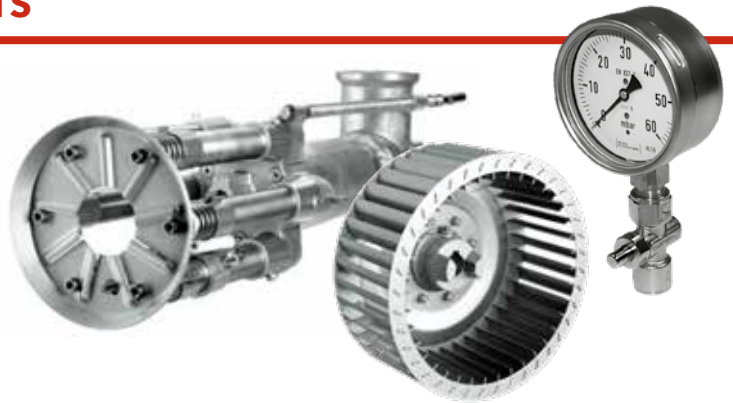

WORLDWIDE NETWORK

Capitalising on more than 90 years of work experience, ELCO has been capable to build up loyal partnerships and today can count on reliable Partners all over the World.

Combining an instinctively global perspective with a genuinely multicultural approach ELCO today offers you skilled and experienced experts available in more than 70 Countries.

- 3 production plants
- 6 commercial branches
- Strong commercial presence through a network of reliable dealers and partners

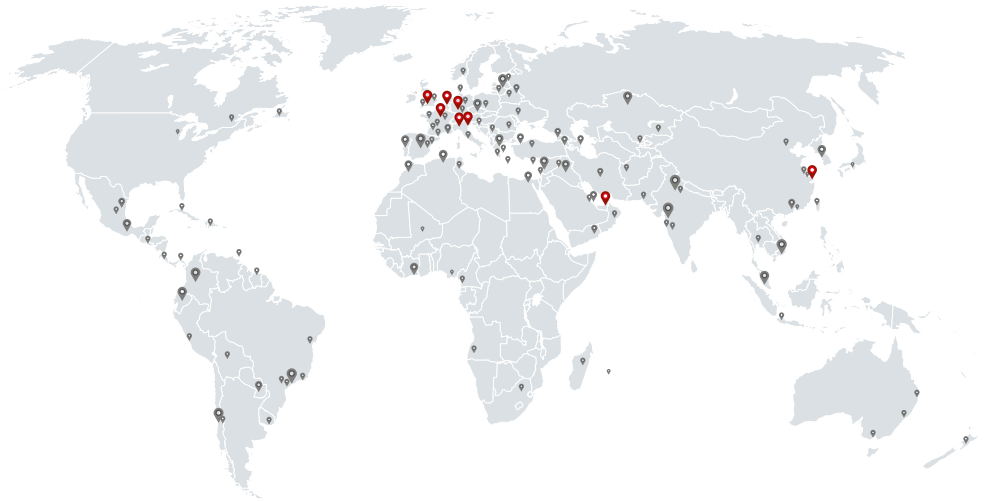

Service Network

In Western Europe, ELCO has a well organised service network. Outside Western Europe ELCO uses a network of partners, consisting of well-trained local engineers, to carry out its service operations.

These technicians are able to perform both commissioning and local service and they do it in a very professional and efficient way.

ELCO ON THE WEB

We are constantly looking forward to provide to our customers new technologies, products and services. Stay always up to date on the latest news from the ELCO World visiting our website:

www.elco-burners.com

Navigate to explore the ELCO proposal and choose the perfect product to fit your needs, and follow us to know more about our new activities and projects.

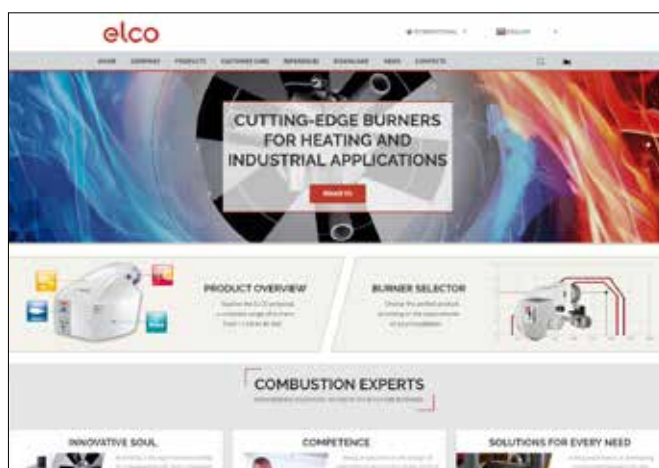

ELCO SYSTEMS AND TECHNOLOGIES

To constantly improve its products, ELCO is committed to develop innovative technological solutions allowing to optimise the running of the installations, to ease technicians work, and naturally to preserve the environment. In order to provide quick responses to its market's demands, the range of ELCO burners is entirely conceived around a consistent combination of Systems.

MDE2 SYSTEM

Permanent communication of information easy to use



Equipped with the MDE2 System, the universal language Elcogram and the 5-button keyboard, ELCO burners adjust themselves and constantly communicate to the technicians and operators:

- real time information about each ignition and during the running;
- statistical information about the burner operations recorded during the whole year before the maintenance operations.

"ELCOGRAM":
universal language
based on symbols
and numerical data

Display shows
all information for
daily operation

Menu-driven burner
setup and operation
via keypad

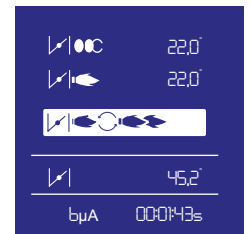
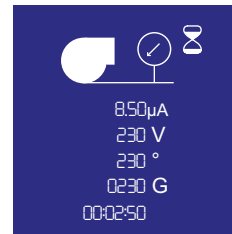
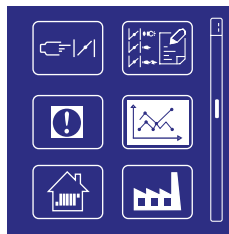

Elcogram, a universal language

As ELCO products are distributed worldwide, the company has developed a universal language composed of pictograms and numerical data. The pictograms use the majority of the symbols used on the wiring diagrams which are recognised and understood by all Nations. This ensures that information is easier to read than ever before.

CMS SYSTEM

The evolution of combustion management systems



CMS is a state of the art system for burner management that sets new standards in control automation. The system provides a full combustion management solution that meets all relevant safety standards, and is certified for all main markets and Standards.

CMS system is simple and easily configurable to meet a wide range of application requirements, from low cost to high end solutions, for industrial or residential applications.

The CMS grants efficient communication via BUS and is extremely flexible due to the fact that is fully configurable, fully compatible with external devices/systems and fully scalable, allowing additional functions, such as VSD fan control, oxygen trim and CO control.

A wide number of interfaces are available, from low-cost keypad to high-resolution touchscreens, allowing intuitive and easy interaction between user and machine.



ELCO SYSTEMS AND TECHNOLOGIES

GEM SYSTEM

Electronic burner control: high safety and low costs



The use of electronic technologies in burner control systems helps to reduce running costs, improve reliability of operation and lower pollutant emissions.

The electronic combustion manager used on ELCO burners are responsible not only for the burner control but also for the fuel/air regulation. Data stored electronically has replaced the mechanical characteristic curve and help to achieve an unprecedented level of precision in air/fuel ratio regulation across the burner's entire control range, a pre-requisite for efficient, energy- and cost-saving operation.

An additional advantage of the GEM is that it provides specific information on all the commands and current situation of the overall system: these can be accessed directly or by remote control.

The digital programming is user-friendly, it is carried out through the display of the MDE2 System or through a PC by using a simple procedure facilitated by easy instructions in a clear language.

VARIATRON

Speed regulation: noise reduction and energy saving



To improve the performance of heating or industrial systems, ELCO applies Variatron (fan speed control).

Conventionally, the air in modulating burners is regulated by an air flap. In the partial load range, a large amount of the air pressure generated by the ventilator goes to waste. With speed regulation, the speed of the combustion/air fan is varied continuously depending on the burner output required: full speed is reached only at maximum burner output. In the predominant partial load range, lower speed translates into significant reductions in power consumption and noise emissions.

The Variatron operates in step with the air damper both with the GEM System, which guarantees a combustion with minimum air excess by continuously monitoring all operating conditions.

Application of the Variatron to ELCO burners results in:

- electrical consumption savings in the order of 50%;
- turndown ratio of up to 1:10, resulting in perfect adaptation to system requirements and improvement in average seasonal efficiency, in particular with condensing or low-temperature boilers or specific processes;
- silent start-up and average overall noise reduction between 2 and 12 dB(A) (at minimum and maximum power).

RTC SYSTEM

Rapid and easy maintenance solutions



The functional housing design of all ELCO burners, combined with the innovative combustion head technologies, creates the RTC System (Retained Head Adjustment) and provides the user with several advantages:

- full access to all components, by simply removing the upper cover;
- complete removal of the combustion head and access to its internal components with a single operation, without removing the burner from the boiler or disconnecting the gas train;
- maintenance of the adjustments made to the combustion head, which are not changed during service operations;
- quick cleaning of mechanical components, thanks to their optimized arrangement;
- reduced servicing times through the use of standard nuts, bolts, screws and pipe fittings, which can be adjusted using only a few tools.

The combination of all these technical solutions makes it possible to simplify and speed up all the operations carried out on the burner, reducing downtime and cost of maintenance.

COMBUSTION TECHNOLOGIES

MULTI-STAGE HEAD (X2)

Clean emissions and flame stability



The principle of the Multi-Stage combustion head is based on the separation of the flame in multiple areas. The result of this process is a significant reduction of the temperature of the flame and, as a direct consequence of this, a drop of the NO_x emission.

The implementation of this technology does not result only in lowering the pollutant emissions but also assure a very stable flame in all operation conditions.

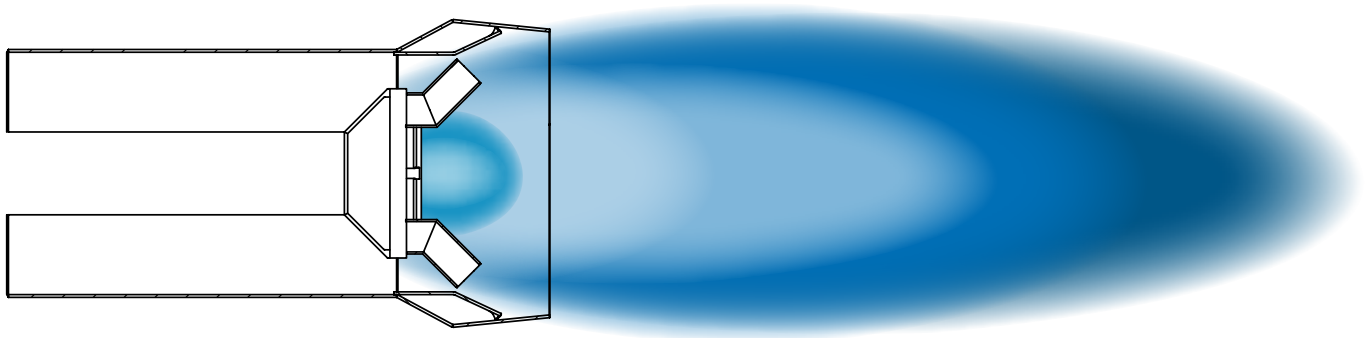

FREE FLAME (F3, F4)

The pinnacle of low-polluting burner engineering



The Free Flame combustion technology is based on the internal recirculation of the flue gas, combined with high speed flow of the fuel air mixture.

The flame stabilizes at a certain distance from the combustion head, thus leaving space for the mixture of reagents and flue gas. This phenomenon greatly reduces NO_x emissions.

The flame seems to float in the furnace, thus giving the system its name: "Free Flame".

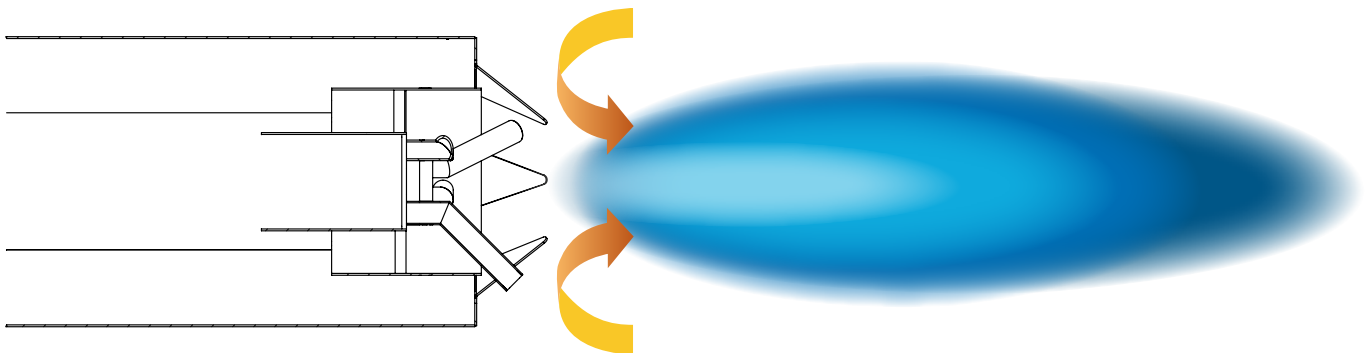

FGR SYSTEM

Ultra low NOx solutions to reach emissions of less than 30 mg/kWh



ELCO has an enormous experience in the application of low emissions systems, going back to the early 90s, when the first Low NOx installation have been successfully commissioned. Thanks to this experience and the technologies developed over the years, ELCO offers a wide range of products which use the external FGR technology to reduce NOx emissions and satisfy even the most stringent regulations. The external recirculation sends a mixture of air and flue gas to the burner combustion head. The gases are mixed upline of the combustion process by the burner fan (for monoblock units) or by the external fan (in case of duoblock burners).

Functional scheme on monoblock burners

The FGR system on monoblock burners provides that the flue gas is drawn in by the burner fan. The installer must therefore install a line connecting the flue gas outlet to the burner fan inlet.

The extraction point is generally at the base of the flue pipe, where the pressure is close to zero. A suction is generated in the burner intake box which is a function of the fan curve and the air damper position.

In order to ensure an adequate rate of flue gas from the stack and thus to provide the required NOx reduction, the pipeline between the flue and the burner must be sized to minimise the pressure drop.

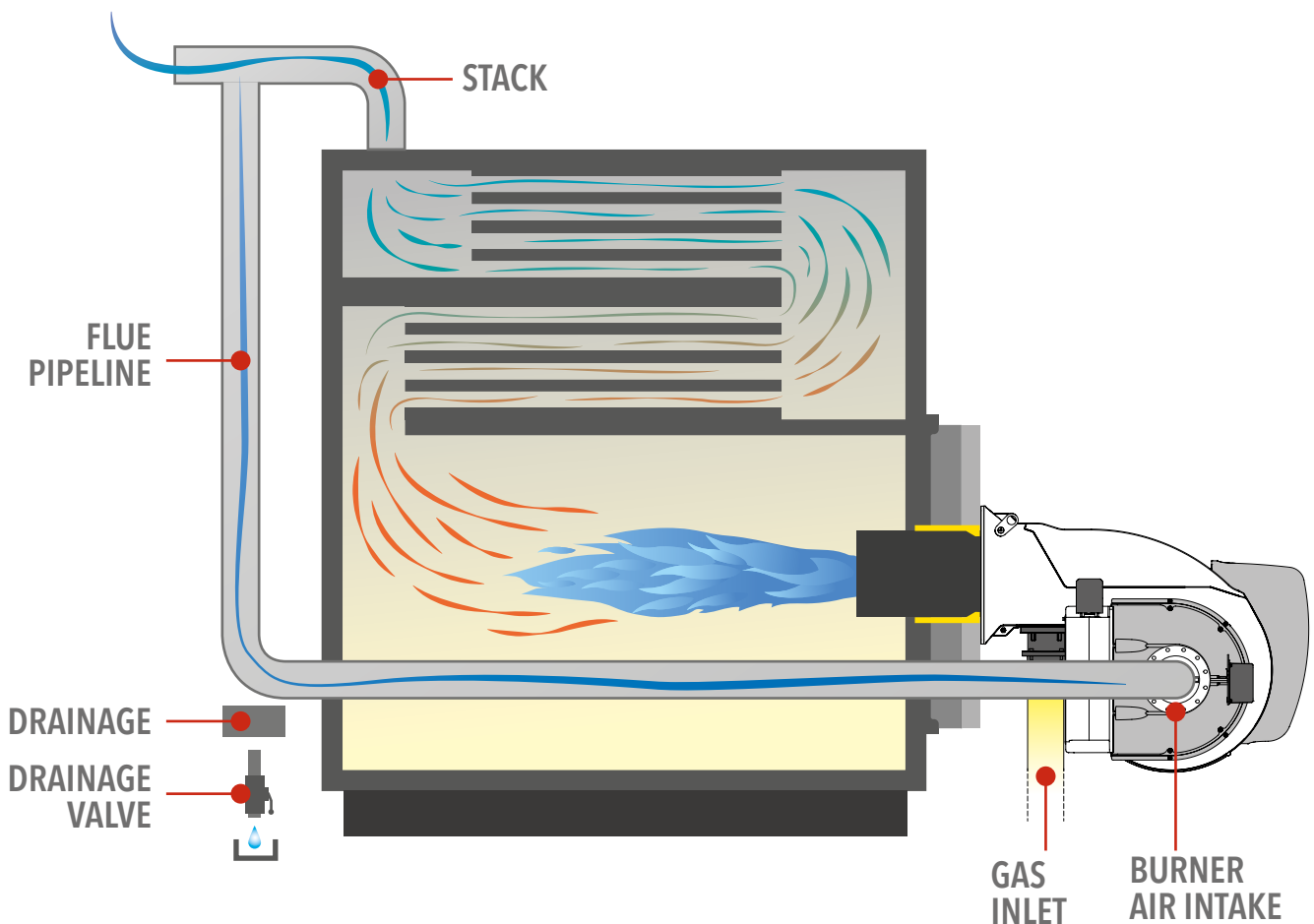

EK-TRON

**MONOBLOCK BURNERS
FROM 320 TO 6050 kW
GAS AND DUAL FUEL**



ROBUST AND RELIABLE DESIGN

The structure of the EK-TRON is the result of a successful synergy between ELCO key features and technologies, developed to meet the needs of any heating application and industrial process.

The essential and simple design of the EK-TRON allows perfect adaptation to any conditions, thanks to the optimal combination of resistant and reliable materials, extreme ease of use and great comfort during daily operation.

FLEXIBILITY AND VERSATILITY

The EK-TRON are characterized by a high flexibility of installation and operation.

They have been designed to be installed in different ways: up-firing, down-firing, upside-down or side-to-side (twin chamber boilers).

Options and configurations have been foreseen in order to fulfill any application need.

CLEAN AND STEADY COMBUSTION

The ELCO combustion technologies are capable to reach the NO_x levels required by the most severe standards for all types of boiler furnaces, even the most narrow ones.

The combination of internal and external recirculation, studied in our laboratories, allows EK-TRON burners to reach extremely low emissions value (between 25 and 28 NO_x mg/kWh at 3% of O₂).

EFFICIENT AND PRACTICAL OPERATIONS

All the models in the series are available with mechanical operation or in a fully electronic configuration.

The electronic versions are equipped with the exclusive ELCO man-machine interface allowing simple and effective programming operations. This results in smooth and performing operation and a quick and simple interaction between the user and the burner.

RANGE OVERVIEW

GAS



/ LOW NO_x CLASS 3
350 / 5500 kW
Page 14

/ LOW NO_x CLASS 2
340 / 6050 kW
Page 22

/ ULTRA LOW NO_x
420 / 3600 kW
Page 30

DUAL FUEL



/ LOW NO_x CLASS 3 in gas
320 / 3900 kW
Page 38

MAIN TECHNICAL FEATURES

- Two stage progressive/modulating forced draught burner
- Fully electronic modulation system or mechanical configuration available for each model
- Different combustion technologies available to reduce NOx emissions without compromising the performance and capable to satisfy even the most difficult conditions in terms of combustion chamber dimension:
 - Low NOx class 2 (<120 mg/kWh) according to EN676 Directive
 - Low NOx class 3 (<80 mg/kWh) according to EN676 Directive
 - Ultra Low NOx versions equipped with FGR system to reach NOx values well below 30 mg/kWh
- Simplified switch cabinet to meet the majority of the application requirements
- Redesigned ventilation system for a more compact structure
- Easily adjustable combustion head to adapt to different boiler specifications and emission level requirements
- Flame tube available in different lengths
- Secured burner head adjustments during maintenance (RTC System)
- Closing of the air damper on burner shut-down
- Multiple gas train matching according to the inlet gas pressure
- Gas train factory assembled and tested for tightness and electrical security
- Products are in compliance with EN676 and EN267 European standards and with the following directives:
 - 2014/35/UE Low Voltage Directive
 - 2014/30/UE EMC Directive
 - 2016/426/UE Gas Appliances Regulation
 - 2006/42/EC Machinery Directive
 - 2011/65/EU RoHS2 Directive

DESIGNATION

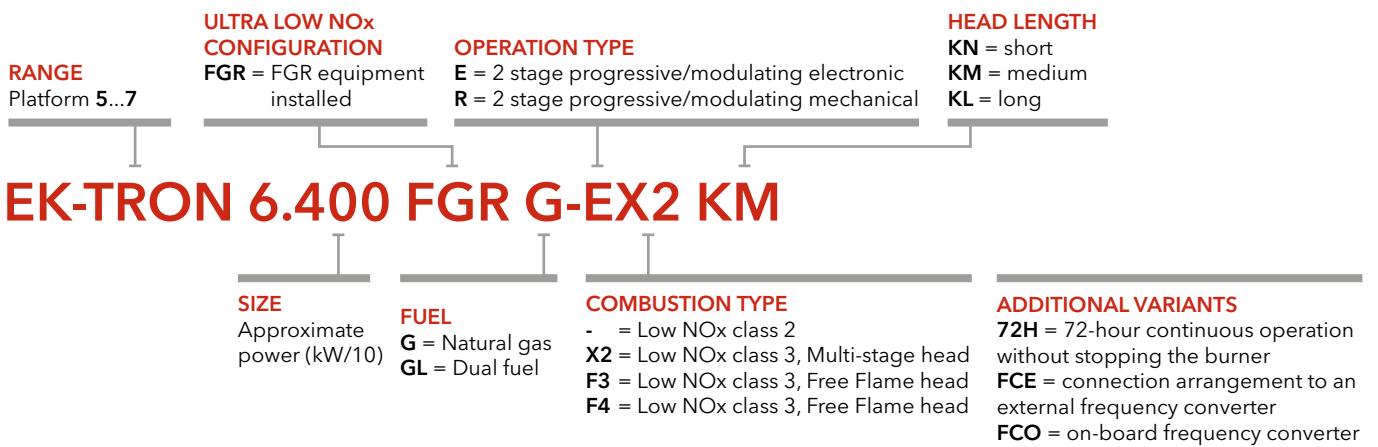

AVAILABLE CONFIGURATIONS

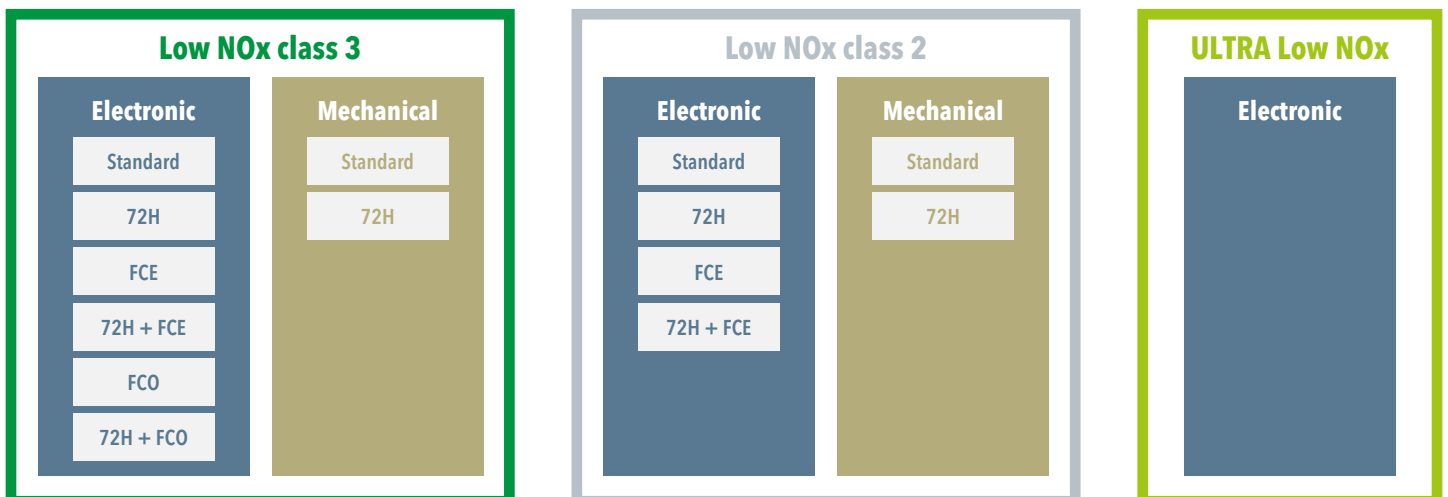

EK-TRON 5 G-EF3, EK-TRON 6 G-EF3, EK-TRON 7 G-EF3

400 ... 5800 kW

Two stage progressive/modulating electronic



- **Fuel:** natural gas, Hi = 6,99 ... 11,39 kWh/Nm³
- **Emissions:** Low NOx class 3 burners (≤80 mg/kWh) according to EN676 Directive equipped with Low NOx Free Flame combustion head
- **Protection level:** IP 40

TECHNICAL DATA

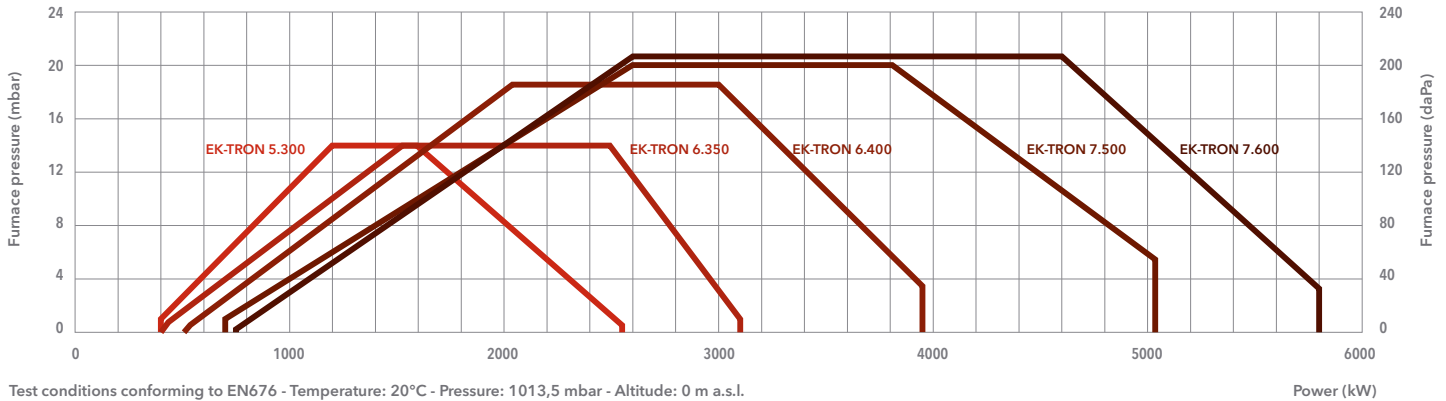

Test conditions conforming to EN676 - Temperature: 20°C - Pressure: 1013,5 mbar - Altitude: 0 m a.s.l.

	EK-TRON 5.300 G-EF3	EK-TRON 6.350 G-EF3	EK-TRON 6.400 G-EF3	EK-TRON 7.500 G-EF3	EK-TRON 7.600 G-EF3
Operating range	400 – 2550 kW	400 – 3100 kW	510 – 3950 kW	700 – 5030 kW	750 – 5800 kW
Gas connection	DN50	DN50	DN65	DN65	DN65
Control box / flame detector	BT320 / QRA2*	BT320 / QRA2*	BT320 / QRA2*	BT320 / QRA2*	BT320 / QRA2*
Auxiliary voltage	1NPE AC 230 V - 50 Hz TN-S	1NPE AC 230 V - 50 Hz TN-S	1NPE AC 230 V - 50 Hz TN-S	1NPE AC 230 V - 50 Hz TN-S	1NPE AC 230 V - 50 Hz TN-S
Power supply	3NPE AC 400 V - 50 Hz	3NPE AC 400 V - 50 Hz	3NPE AC 400 V - 50 Hz	3NPE AC 400 V - 50 Hz	3NPE AC 400 V - 50 Hz
Fan motor	4 kW	5,5 kW	7,5 kW	11 kW	15 kW
Acoustic level	<83 dB(A)	<84 dB(A)	<85 dB(A)	<85 dB(A)	<85 dB(A)
Burner codes (body + head)	KM 3148195	KM 3148425	KM 3148197	KM 3148199	KM 3148201
	KL 3148196	KL 3148426	KL 3148198	KL 3148200	KL 3148202

*: BT330 / FFS08 for 72H versions

OTHER AVAILABLE VERSIONS

Variant		EK-TRON 5.300 G-EF3	EK-TRON 6.350 G-EF3	EK-TRON 6.400 G-EF3	EK-TRON 7.500 G-EF3	EK-TRON 7.600 G-EF3
72H	KM	3148450	3148452	3148454	3148456	3148458
	KL	3148451	3148453	3148455	3148457	3148459
FCE	KM	3148474	3148476	3148478	3148480	3148482
	KL	3148475	3148477	3148479	3148481	3148483
72H + FCE	KM	3148486	3148488	3148490	3148492	3148494
	KL	3148487	3148489	3148491	3148493	3148495
FCO	KM	3148920	3148922	3148924	3148926	3148928
	KL	3148921	3148923	3148925	3148927	3148929
72H + FCO	KM	3148930	3148932	3148934	3148936	3148938
	KL	3148931	3148933	3148935	3148937	3148939

GAS TRAINS AND FILTERS

DUNGS models	Code	SIEMENS models	Code	Filters	Code
GT-D1-MBEVB-RP50-PS2	3148693	GT-S1-VGD20-RP50-PS2	3148683	FG-Rp2"	3757200
GT-D1-MBEVB-DN65-PS2	3148694	GT-S1-VGD40-DN65-PS2	3148684	FG-DN65	3757198
GT-D1-MBEVB-DN80-PS2	3148695	GT-S1-VGD40-DN80-PS2	3148685	FG-DN80	3757201
GT-D1-MBEVB-DN100-PS2	3148696	GT-S1-VGD40-DN100-PS2	3148686	FG-DN100	3757195
		GT-S1-VGD40-DN125-PS2	3148687	FG-DN125	3757209



DIMENSIONS (mm)

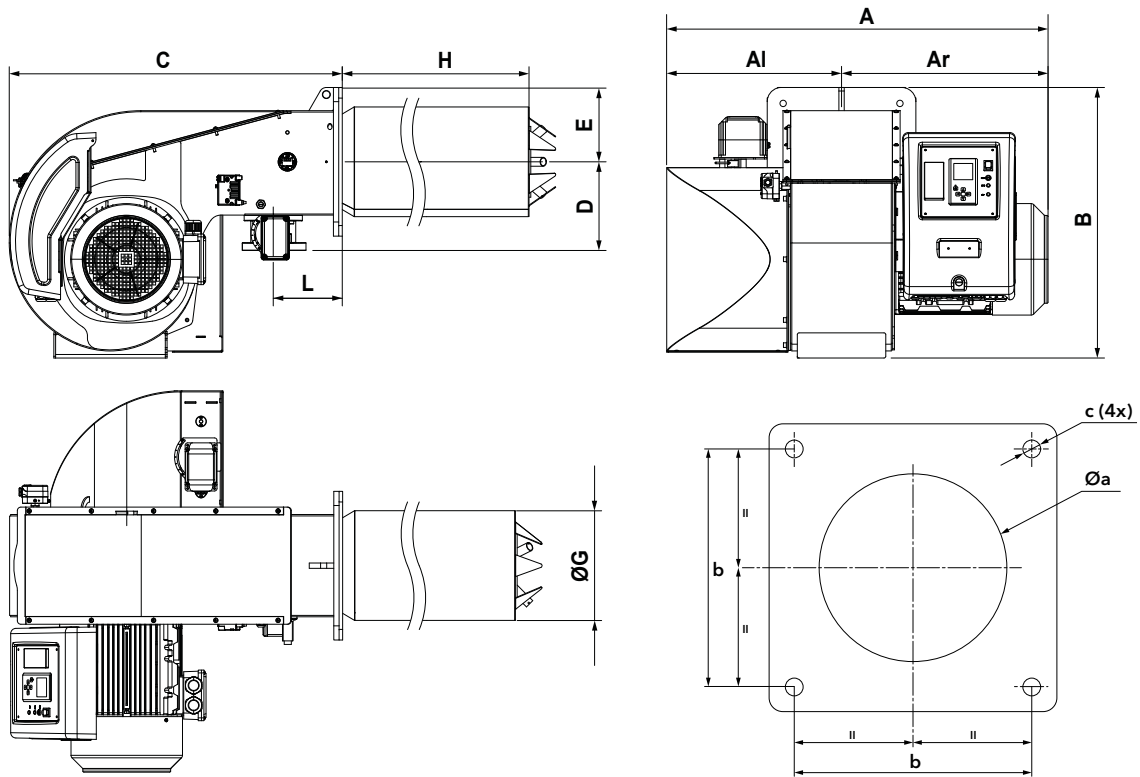

Model	A	Al	Ar	B	C	D	E	ØG	H		L	Øa	b	c
									KM	KL				
EK-TRON 5.300 G-EF3	813	356	457	606	724	245	190	263	540	640	125	278-288	315	M16
EK-TRON 6.350 G-EF3	875	387	488	684	828	250	190	263	550	650	195	278-288	315	M16
EK-TRON 6.400 G-EF3	875	387	488	684	828	250	190	310	548	638	195	325-335	315	M16
EK-TRON 7.500 G-EF3	1083	494	589	780	943	250	210	310	558	688	195	325-335	330	M16
EK-TRON 7.600 G-EF3	1083	494	589	780	943	250	210	323	558	688	195	338-348	330	M16

Note: dimensions may vary depending on the configuration chosen

PACKAGING

The burner is delivered on a pallet with:

- burner body and combustion head (to be mounted by the installer)
- gas train and filter
- boiler fixing accessories
- technical documentation

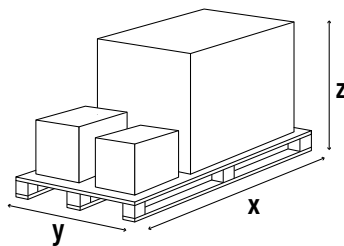

Model	Dimensions (mm)		
	X	Y	Z
EK-TRON 5.300 G-EF3	1100	900	720
EK-TRON 6.350 G-EF3	1100	900	720
EK-TRON 6.400 G-EF3	1100	900	720
EK-TRON 7.500 G-EF3	1300	1050	900
EK-TRON 7.600 G-EF3	1300	1050	900

EK-TRON 5 G-EF3, EK-TRON 6 G-EF3, EK-TRON 7 G-EF3

400 ... 5800 kW

Two stage progressive/modulating electronic

PRESSURE LOSS [BURNER HEAD + GAS TRAIN] (mbar)

EK-TRON 5.300 G-EF3

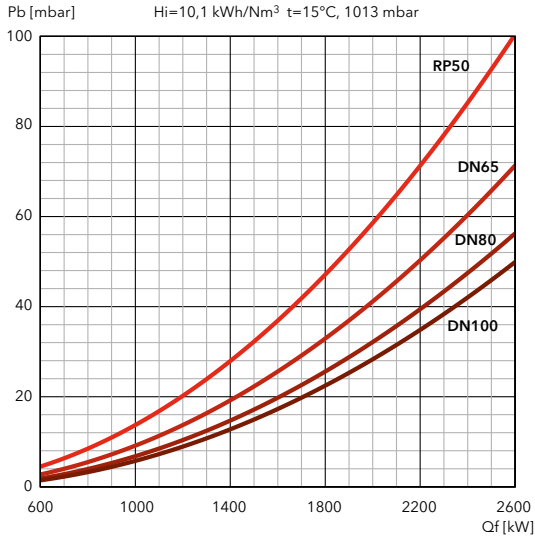

i Each gas train must be installed with its own **connection pipe**, to be selected from the following table:

Gas train model	Code	Connection pipe
GT-S1-VGD20-RP50-PS2	3148683	3144686
GT-S1-VGD40-DN65-PS2	3148684	3148771
GT-S1-VGD40-DN80-PS2	3148685	3148772
GT-S1-VGD40-DN100-PS2	3148686	3148773
GT-D1-MBEVB-RP50-PS2	3148693	3144686
GT-D1-MBEVB-DN65-PS2	3148694	3148771
GT-D1-MBEVB-DN80-PS2	3148695	3148772
GT-D1-MBEVB-DN100-PS2	3148696	3148773

EK-TRON 6.350 G-EF3

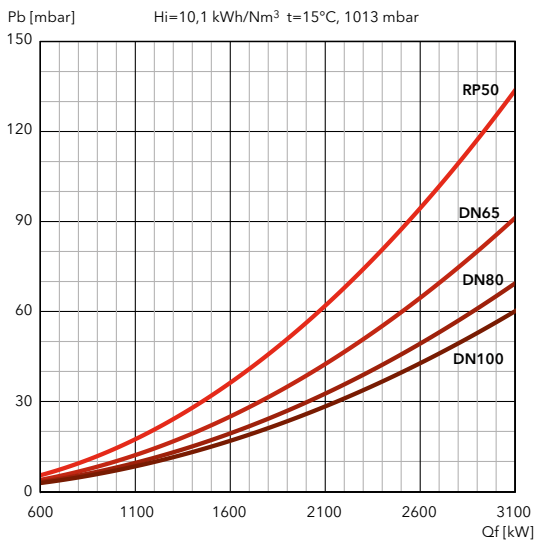

i Each gas train must be installed with its own **connection pipe**, to be selected from the following table:

Gas train model	Code	Connection pipe
GT-S1-VGD20-RP50-PS2	3148683	3144686
GT-S1-VGD40-DN65-PS2	3148684	3148771
GT-S1-VGD40-DN80-PS2	3148685	3148772
GT-S1-VGD40-DN100-PS2	3148686	3148773
GT-D1-MBEVB-RP50-PS2	3148693	3144686
GT-D1-MBEVB-DN65-PS2	3148694	3148771
GT-D1-MBEVB-DN80-PS2	3148695	3148772
GT-D1-MBEVB-DN100-PS2	3148696	3148773

EK-TRON 6.400 G-EF3

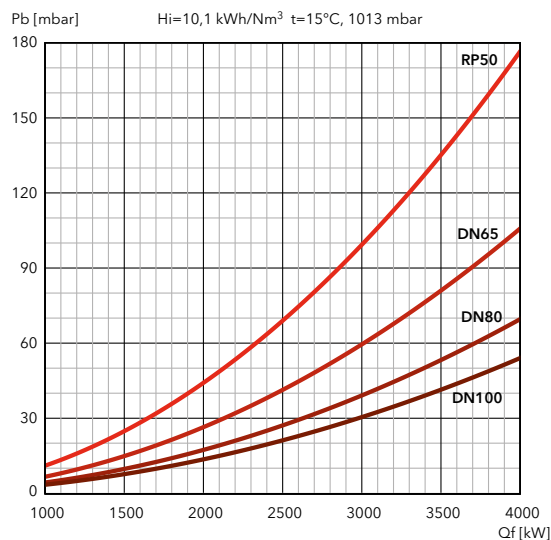

i Each gas train must be installed with its own **connection pipe**, to be selected from the following table:

Gas train model	Code	Connection pipe
GT-S1-VGD20-RP50-PS2	3148683	3148770
GT-S1-VGD40-DN65-PS2	3148684	3145997
GT-S1-VGD40-DN80-PS2	3148685	3145864
GT-S1-VGD40-DN100-PS2	3148686	3145821
GT-D1-MBEVB-RP50-PS2	3148693	3148770
GT-D1-MBEVB-DN65-PS2	3148694	3145997
GT-D1-MBEVB-DN80-PS2	3148695	3145864
GT-D1-MBEVB-DN100-PS2	3148696	3145821



PRESSURE LOSS [BURNER HEAD + GAS TRAIN] (mbar)

EK-TRON 7.500 G-EF3

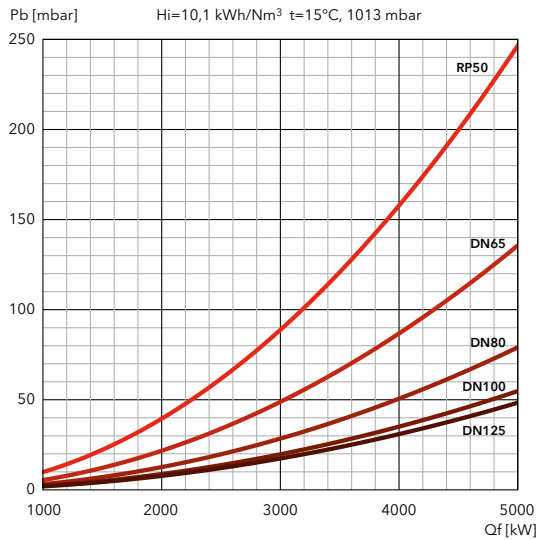

i Each gas train must be installed with its own **connection pipe**, to be selected from the following table:

Gas train model	Code	Connection pipe
GT-S1-VGD20-RP50-PS2	3148683	3148770
GT-S1-VGD40-DN65-PS2	3148684	3148766
GT-S1-VGD40-DN80-PS2	3148685	3148767
GT-S1-VGD40-DN100-PS2	3148686	3148768
GT-S1-VGD40-DN125-PS2	3148687	3148769
GT-D1-MBEVB-RP50-PS2	3148693	3148770
GT-D1-MBEVB-DN65-PS2	3148694	3148766
GT-D1-MBEVB-DN80-PS2	3148695	3148767
GT-D1-MBEVB-DN100-PS2	3148696	3148768

EK-TRON 7.600 G-EF3

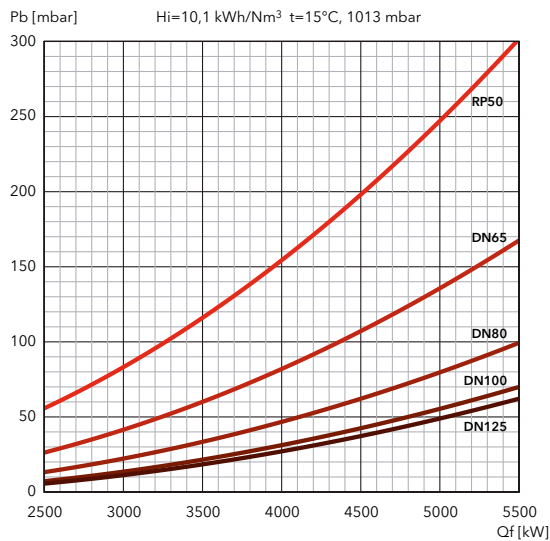

i Each gas train must be installed with its own **connection pipe**, to be selected from the following table:

Gas train model	Code	Connection pipe
GT-S1-VGD20-RP50-PS2	3148683	3148770
GT-S1-VGD40-DN65-PS2	3148684	3148766
GT-S1-VGD40-DN80-PS2	3148685	3148767
GT-S1-VGD40-DN100-PS2	3148686	3148768
GT-S1-VGD40-DN125-PS2	3148687	3148769
GT-D1-MBEVB-RP50-PS2	3148693	3148770
GT-D1-MBEVB-DN65-PS2	3148694	3148766
GT-D1-MBEVB-DN80-PS2	3148695	3148767
GT-D1-MBEVB-DN100-PS2	3148696	3148768

FILTERS

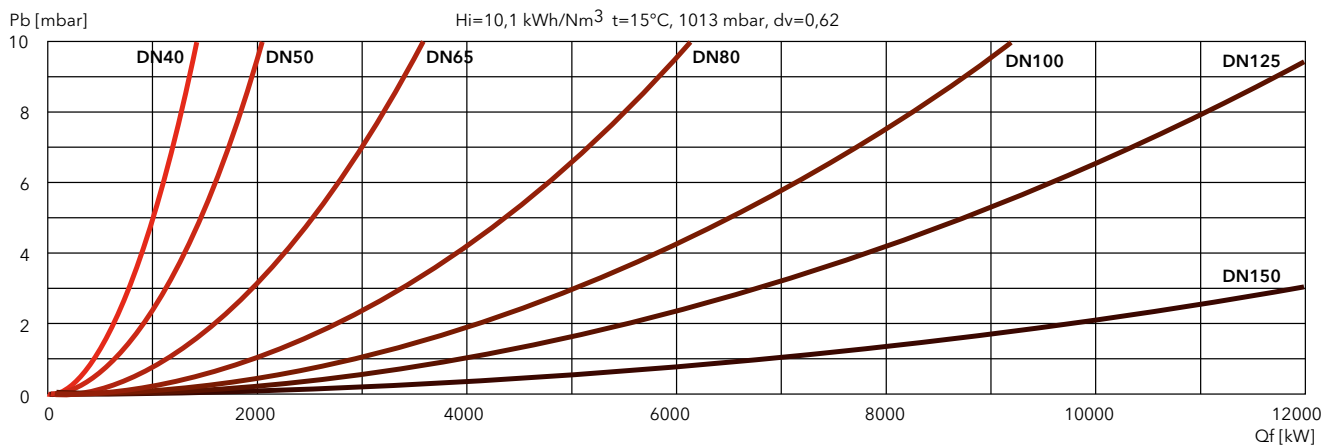

EK-TRON 5 G-RF3, EK-TRON 6 G-RF3, EK-TRON 7 G-RF3

400 ... 5800 kW

Two stage progressive/modulating mechanical



- **Fuel:** natural gas, Hi = 6,99 ... 11,39 kWh/Nm³
- **Emissions:** Low NOx class 3 burners (≤80 mg/kWh) according to EN676 Directive equipped with Low NOx Free Flame combustion head
- **Protection level:** IP 40

TECHNICAL DATA

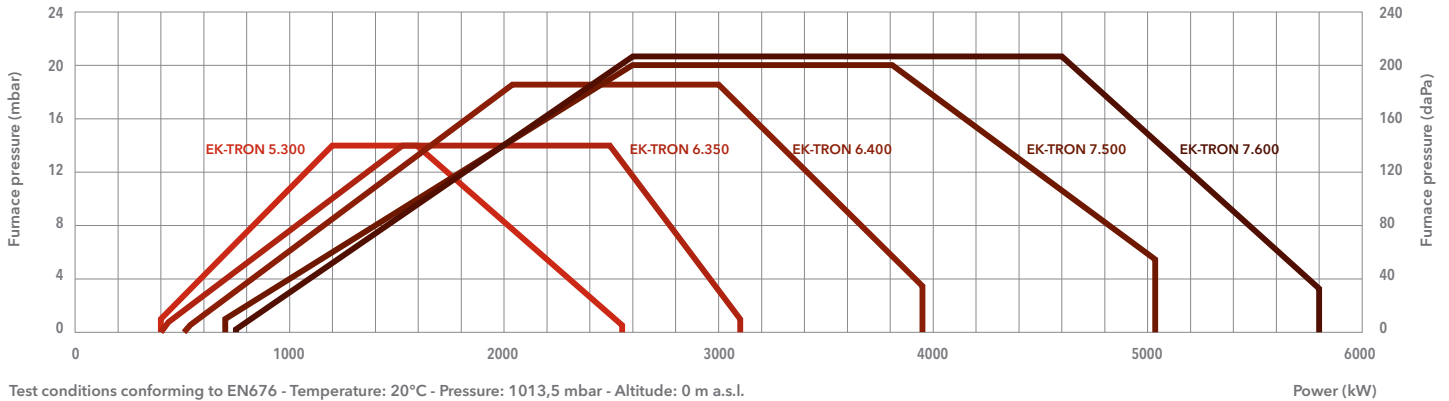

Test conditions conforming to EN676 - Temperature: 20°C - Pressure: 1013,5 mbar - Altitude: 0 m a.s.l.

	EK-TRON 5.300 G-RF3	EK-TRON 6.350 G-RF3	EK-TRON 6.400 G-RF3	EK-TRON 7.500 G-RF3	EK-TRON 7.600 G-RF3
Operating range	400 – 2550 kW	400 – 3100 kW	510 – 3950 kW	700 – 5030 kW	750 – 5800 kW
Gas connection	DN50	DN50	DN65	DN65	DN65
Control box / flame detector	LME73 / QRA2*	LME73 / QRA2*	LME73 / QRA2*	LME73 / QRA2*	LME73 / QRA2*
Auxiliary voltage	1NPE AC 230 V - 50 Hz TN-S	1NPE AC 230 V - 50 Hz TN-S	1NPE AC 230 V - 50 Hz TN-S	1NPE AC 230 V - 50 Hz TN-S	1NPE AC 230 V - 50 Hz TN-S
Power supply	3NPE AC 400 V - 50 Hz	3NPE AC 400 V - 50 Hz	3NPE AC 400 V - 50 Hz	3NPE AC 400 V - 50 Hz	3NPE AC 400 V - 50 Hz
Fan motor	4 kW	5,5 kW	7,5 kW	11 kW	15 kW
Acoustic level	<83 dB(A)	<84 dB(A)	<85 dB(A)	<85 dB(A)	<85 dB(A)
Burner codes (body + head)	KM 3148297	KM 3148427	KM 3148299	KM 3148301	KM 3148303
	KL 3148298	KL 3148428	KL 3148300	KL 3148302	KL 3148304

*: LME75 / QRA73 for 72H versions

OTHER AVAILABLE VERSIONS

Variant		EK-TRON 5.300 G-RF3	EK-TRON 6.350 G-RF3	EK-TRON 6.400 G-RF3	EK-TRON 7.500 G-RF3	EK-TRON 7.600 G-RF3
72H	KM	3148462	3148464	3148466	3148468	3148470
	KL	3148463	3148465	3148467	3148469	3148471

GAS TRAINS AND FILTERS

DUNGS models	Code
GT-D1-MBEVB-RP50-PS3	3148697
GT-D1-MBEVB-DN65-PS3	3148698
GT-D1-MBEVB-DN80-PS3	3148699
GT-D1-MBEVB-DN100-PS3	3148700

SIEMENS models	Code
GT-S1-VGD20-RP50-PS3	3148688
GT-S1-VGD40-DN65-PS3	3148689
GT-S1-VGD40-DN80-PS3	3148690
GT-S1-VGD40-DN100-PS3	3148691
GT-S1-VGD40-DN125-PS3	3148692

Filters	Code
FG-Rp2"	3757200
FG-DN65	3757198
FG-DN80	3757201
FG-DN100	3757195
FG-DN125	3757209

DIMENSIONS (mm)

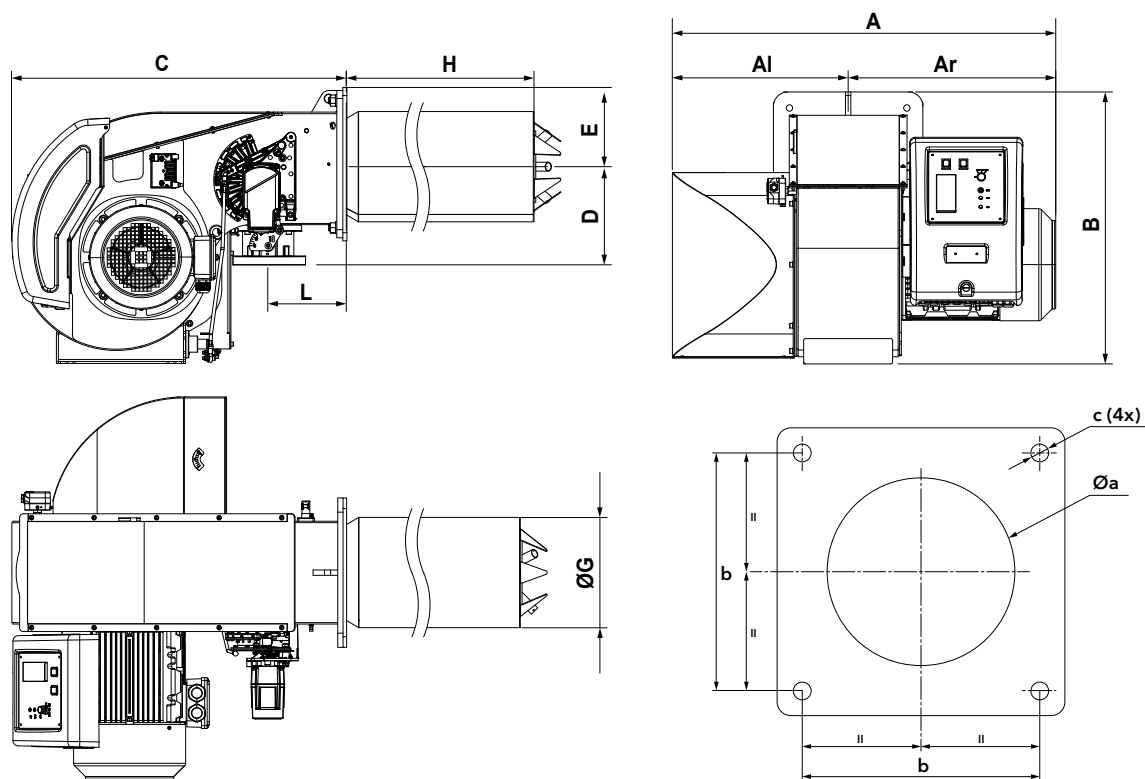

Model	A	Al	Ar	B	C	D	E	ØG	H		L	Øa	b	c
									KM	KL				
EK-TRON 5.300 G-RF3	813	356	457	606	724	245	190	263	540	640	125	278-288	315	M16
EK-TRON 6.350 G-RF3	875	387	488	684	828	250	190	263	550	650	195	278-288	315	M16
EK-TRON 6.400 G-RF3	875	387	488	684	828	250	190	310	548	638	195	325-335	315	M16
EK-TRON 7.500 G-RF3	1083	494	589	780	943	250	210	310	558	688	195	325-335	330	M16
EK-TRON 7.600 G-RF3	1083	494	589	780	943	250	210	323	558	688	195	338-348	330	M16

PACKAGING

The burner is delivered on a pallet with:

- burner body and combustion head (to be mounted by the installer)
- gas train and filter
- boiler fixing accessories
- technical documentation

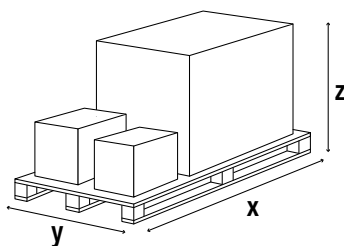

Model	Dimensions (mm)		
	X	Y	Z
EK-TRON 5.300 G-RF3	1100	900	720
EK-TRON 6.350 G-RF3	1100	900	720
EK-TRON 6.400 G-RF3	1100	900	720
EK-TRON 7.500 G-RF3	1300	1050	900
EK-TRON 7.600 G-RF3	1300	1050	900

EK-TRON 5 G-RF3, EK-TRON 6 G-RF3, EK-TRON 7 G-RF3

400 ... 5800 kW

Two stage progressive/modulating mechanical

PRESSURE LOSS [BURNER HEAD + GAS TRAIN] (mbar)

EK-TRON 5.300 G-RF3

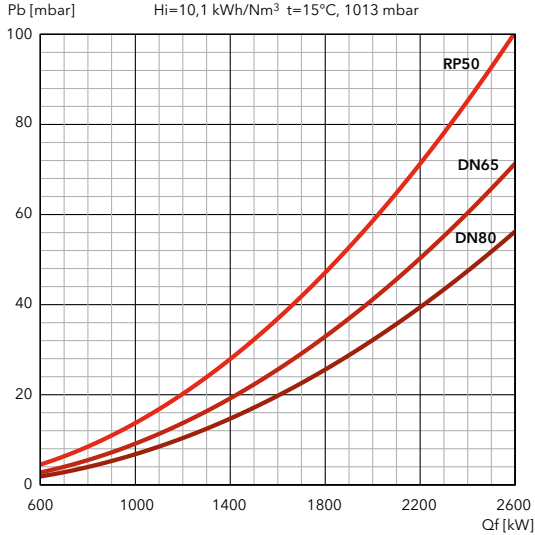

i Each gas train must be installed with its own **connection pipe**, to be selected from the following table:

Gas train model	Code	Connection pipe
GT-S1-VGD20-RP50-PS3	3148688	3144686
GT-S1-VGD40-DN65-PS3	3148689	3148771
GT-S1-VGD40-DN80-PS3	3148690	3148772
GT-D1-MBEVB-RP50-PS3	3148697	3144686
GT-D1-MBEVB-DN65-PS3	3148698	3148771
GT-D1-MBEVB-DN80-PS3	3148699	3148772

EK-TRON 6.350 G-RF3

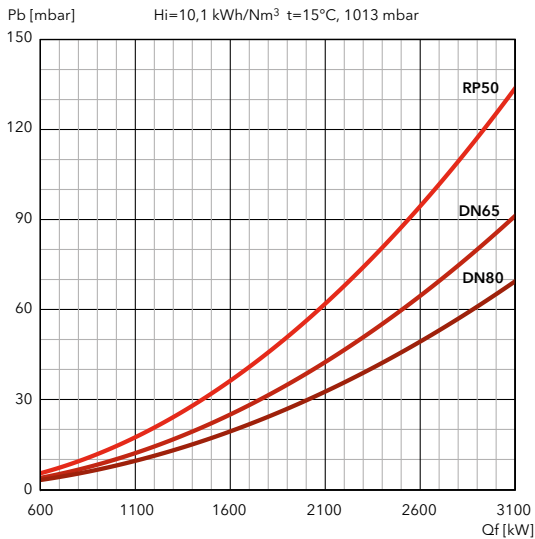

i Each gas train must be installed with its own **connection pipe**, to be selected from the following table:

Gas train model	Code	Connection pipe
GT-S1-VGD20-RP50-PS3	3148688	3144686
GT-S1-VGD40-DN65-PS3	3148689	3148771
GT-S1-VGD40-DN80-PS3	3148690	3148772
GT-D1-MBEVB-RP50-PS3	3148697	3144686
GT-D1-MBEVB-DN65-PS3	3148698	3148771
GT-D1-MBEVB-DN80-PS3	3148699	3148772

EK-TRON 6.400 G-RF3

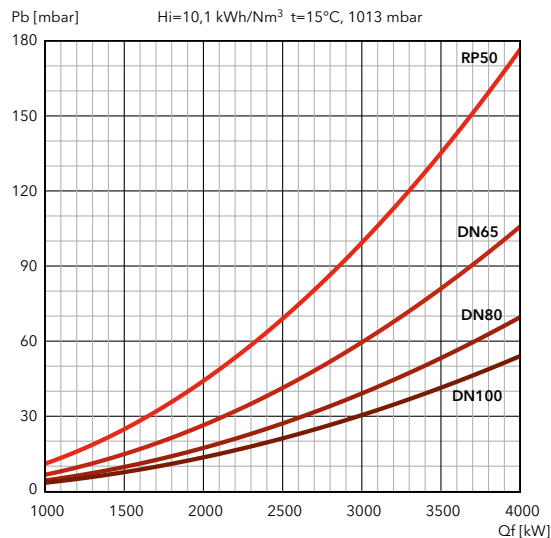

i Each gas train must be installed with its own **connection pipe**, to be selected from the following table:

Gas train model	Code	Connection pipe
GT-S1-VGD20-RP50-PS3	3148688	3148770
GT-S1-VGD40-DN65-PS3	3148689	3145997
GT-S1-VGD40-DN80-PS3	3148690	3145864
GT-S1-VGD40-DN100-PS3	3148691	3145821
GT-D1-MBEVB-RP50-PS3	3148697	3148770
GT-D1-MBEVB-DN65-PS3	3148698	3145997
GT-D1-MBEVB-DN80-PS3	3148699	3145864
GT-D1-MBEVB-DN100-PS3	3148700	3145821

PRESSURE LOSS [BURNER HEAD + GAS TRAIN] (mbar)

EK-TRON 7.500 G-RF3

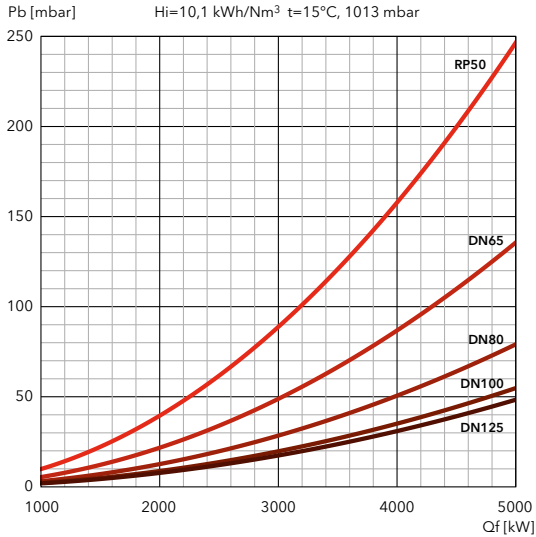

i Each gas train must be installed with its own **connection pipe**, to be selected from the following table:

Gas train model	Code	Connection pipe
GT-S1-VGD20-RP50-PS3	3148688	3148770
GT-S1-VGD40-DN65-PS3	3148689	3148766
GT-S1-VGD40-DN80-PS3	3148690	3148767
GT-S1-VGD40-DN100-PS3	3148691	3148768
GT-S1-VGD40-DN125-PS3	3148692	3148769
GT-D1-MBEVB-RP50-PS3	3148697	3148770
GT-D1-MBEVB-DN65-PS3	3148698	3148766
GT-D1-MBEVB-DN80-PS3	3148699	3148767
GT-D1-MBEVB-DN100-PS3	3148700	3148768

EK-TRON 7.600 G-RF3

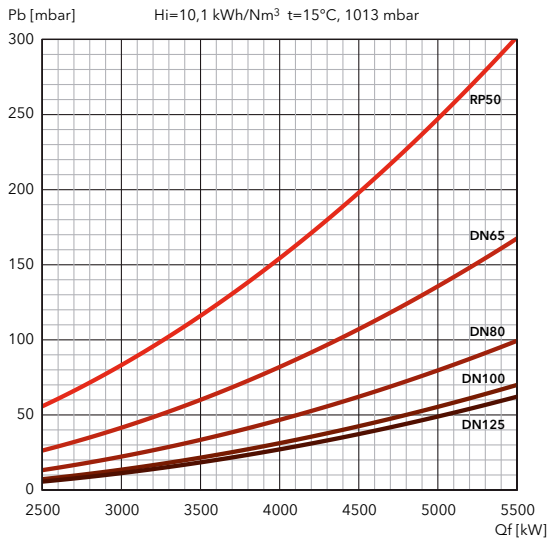

i Each gas train must be installed with its own **connection pipe**, to be selected from the following table:

Gas train model	Code	Connection pipe
GT-S1-VGD20-RP50-PS3	3148688	3148770
GT-S1-VGD40-DN65-PS3	3148689	3148766
GT-S1-VGD40-DN80-PS3	3148690	3148767
GT-S1-VGD40-DN100-PS3	3148691	3148768
GT-S1-VGD40-DN125-PS3	3148692	3148769
GT-D1-MBEVB-RP50-PS3	3148697	3148770
GT-D1-MBEVB-DN65-PS3	3148698	3148766
GT-D1-MBEVB-DN80-PS3	3148699	3148767
GT-D1-MBEVB-DN100-PS3	3148700	3148768

FILTERS

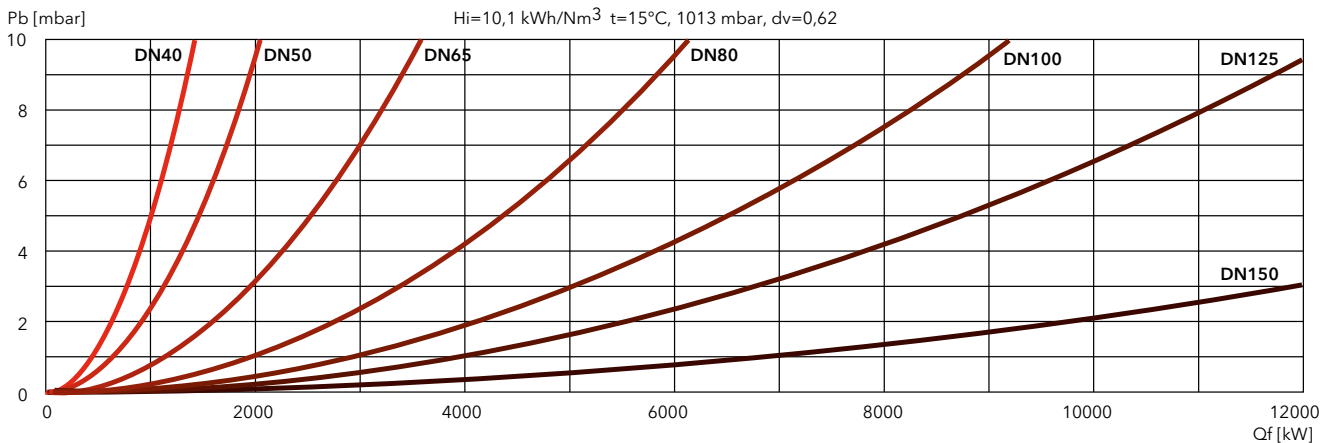

EK-TRON 5 G-E, EK-TRON 6 G-E, EK-TRON 7 G-E

340 ... 6050 kW

Two stage progressive/modulating electronic



- **Fuel:** natural gas, Hi = 6,99 ... 11,39 kWh/Nm³
- **Emissions:** Low NOx class 2 burners (≤120 mg/kWh) according to EN676 Directive
- **Protection level:** IP 40

TECHNICAL DATA

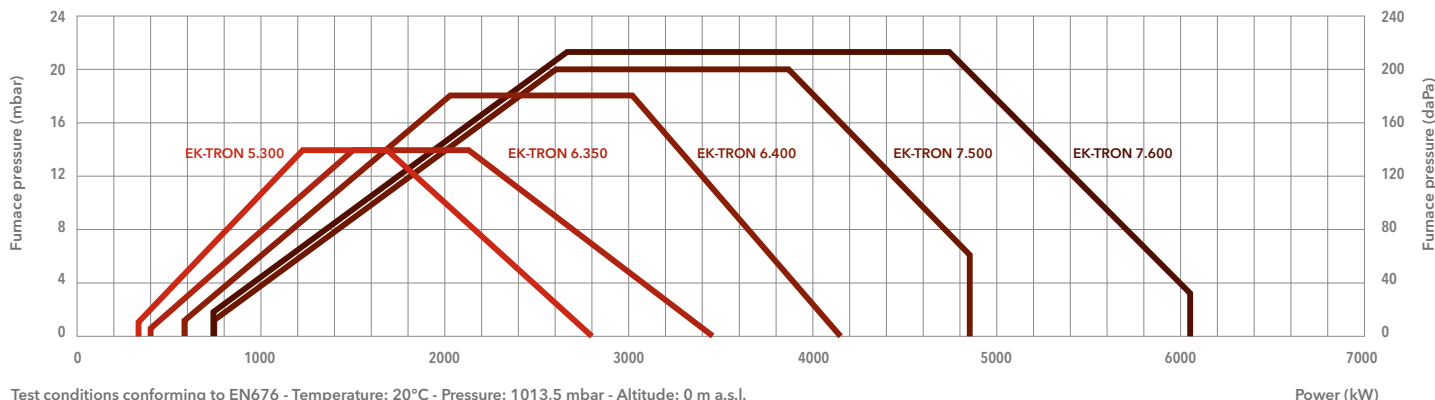

Test conditions conforming to EN676 - Temperature: 20°C - Pressure: 1013,5 mbar - Altitude: 0 m a.s.l.

	EK-TRON 5.300 G-E	EK-TRON 6.350 G-E	EK-TRON 6.400 G-E	EK-TRON 7.500 G-E	EK-TRON 7.600 G-E
Operating range	340 - 2800 kW	400 - 3450 kW	590 - 4150 kW	750 - 4850 kW	740 - 6050 kW
Gas connection	DN50	DN50	DN65	DN65	DN65
Control box / flame detector	BT320* / ionization	BT320* / ionization	BT320* / ionization	BT320* / ionization	BT320* / ionization
Auxiliary voltage	1NPE AC 230 V - 50 Hz TN-S	1NPE AC 230 V - 50 Hz TN-S	1NPE AC 230 V - 50 Hz TN-S	1NPE AC 230 V - 50 Hz TN-S	1NPE AC 230 V - 50 Hz TN-S
Power supply	3NPE AC 400 V - 50 Hz	3NPE AC 400 V - 50 Hz	3NPE AC 400 V - 50 Hz	3NPE AC 400 V - 50 Hz	3NPE AC 400 V - 50 Hz
Fan motor	4 kW	5,5 kW	7,5 kW	11 kW	15 kW
Acoustic level	<83 dB(A)	<84 dB(A)	<85 dB(A)	<85 dB(A)	<85 dB(A)
Burner codes (body + head)	KN	3148784	3148785	3148786	3148787
	KM	3148325	3148327	3148329	3148331
	KL	3148326	3148328	3148330	3148332

*: BT330 for 72H versions

OTHER AVAILABLE VERSIONS

Variant		EK-TRON 5.300 G-E	EK-TRON 6.350 G-E	EK-TRON 6.400 G-E	EK-TRON 7.500 G-E	EK-TRON 7.600 G-E
72H	KN	3148794	3148795	3148796	3148797	3148798
	KM	3148498	3148500	3148502	3148504	3148506
	KL	3148499	3148501	3148503	3148505	3148507
FCE	KN	3148804	3148805	3148806	3148807	3148808
	KM	3148522	3148524	3148526	3148528	3148530
	KL	3148523	3148525	3148527	3148529	3148531
72H + FCE	KN	3148809	3148810	3148811	3148812	3148813
	KM	3148534	3148536	3148538	3148540	3148542
	KL	3148535	3148537	3148539	3148541	3148543

GAS TRAINS AND FILTERS

DUNGS models	Code	SIEMENS models	Code	Filters	Code
GT-D1-MBEVB-RP50-PS2	3148693	GT-S1-VGD20-RP50-PS2	3148683	FG-Rp2"	3757200
GT-D1-MBEVB-DN65-PS2	3148694	GT-S1-VGD40-DN65-PS2	3148684	FG-DN65	3757198
GT-D1-MBEVB-DN80-PS2	3148695	GT-S1-VGD40-DN80-PS2	3148685	FG-DN80	3757201
GT-D1-MBEVB-DN100-PS2	3148696	GT-S1-VGD40-DN100-PS2	3148686	FG-DN100	3757195
		GT-S1-VGD40-DN125-PS2	3148687	FG-DN125	3757209



DIMENSIONS (mm)

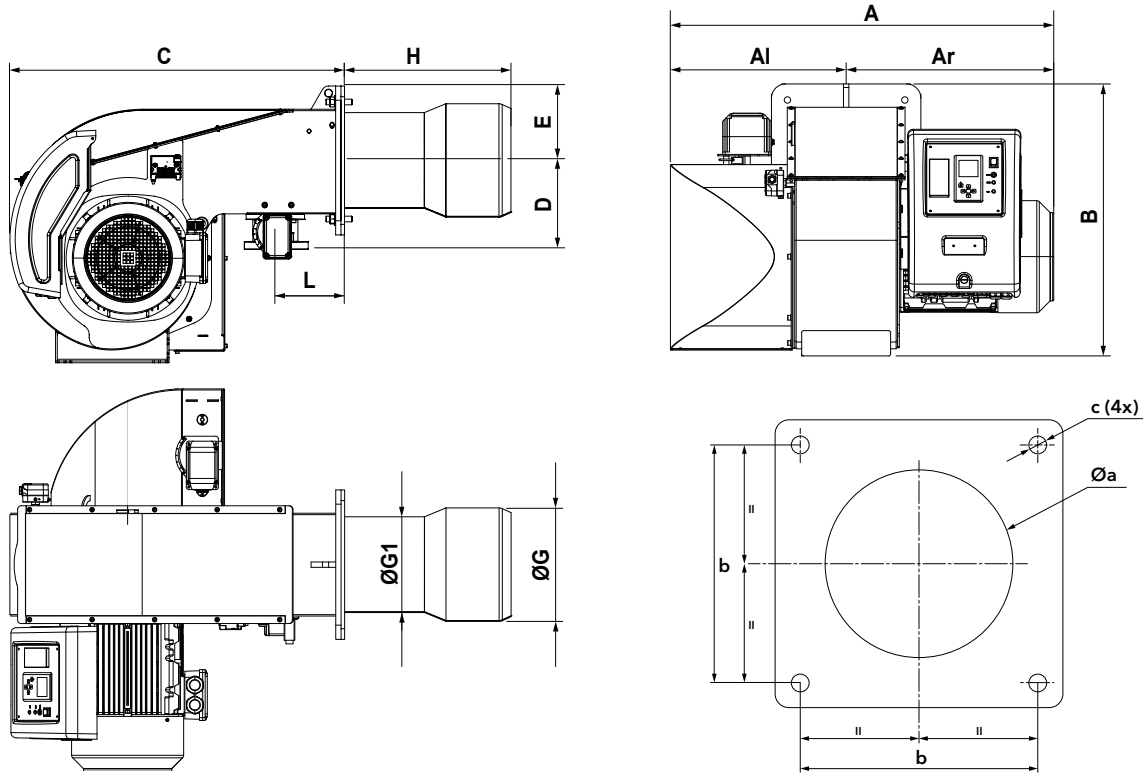

Model	A	A1	Ar	B	C	D	E	ØG	ØG1	H			L	Øa	b	c
										KN	KM	KL				
EK-TRON 5.300 G-E	813	356	457	606	714	245	190	300	216	385	485	585	125	315-325	315	M16
EK-TRON 6.350 G-E	875	387	488	684	828	245	190	290	240	328	428	528	195	305-315	315	M16
EK-TRON 6.400 G-E	875	387	488	684	828	250	190	320	270	392	448	563	195	335-345	315	M16
EK-TRON 7.500 G-E	1083	494	589	780	943	251	210	320	270	373	470	573	195	335-345	330	M16
EK-TRON 7.600 G-E	1083	494	589	780	943	251	210	360	270	373	470	573	195	375-385	330	M16

PACKAGING

The burner is delivered on a pallet with:

- burner body and combustion head (to be mounted by the installer)
- gas train and filter
- boiler fixing accessories
- technical documentation

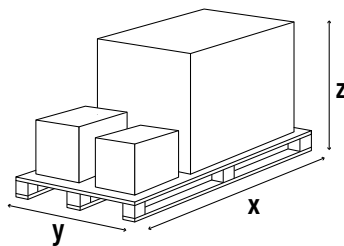

Model	Dimensions (mm)		
	X	Y	Z
EK-TRON 5.300 G-E	1100	900	720
EK-TRON 6.350 G-E	1100	900	720
EK-TRON 6.400 G-E	1100	900	720
EK-TRON 7.500 G-E	1300	1050	900
EK-TRON 7.600 G-E	1300	1050	900

EK-TRON 5 G-E, EK-TRON 6 G-E, EK-TRON 7 G-E

340 ... 6050 kW

Two stage progressive/modulating electronic

PRESSURE LOSS [BURNER HEAD + GAS TRAIN] (mbar)

EK-TRON 5.300 G-E

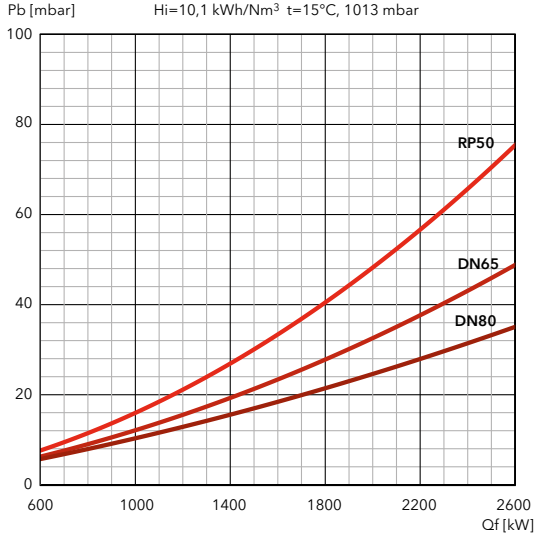

i Each gas train must be installed with its own **connection pipe**, to be selected from the following table:

Gas train model	Code	Connection pipe
GT-S1-VGD20-RP50-PS2	3148683	3144686
GT-S1-VGD40-DN65-PS2	3148684	3148771
GT-S1-VGD40-DN80-PS2	3148685	3148772
GT-D1-MBEVB-RP50-PS2	3148693	3144686
GT-D1-MBEVB-DN65-PS2	3148694	3148771
GT-D1-MBEVB-DN80-PS2	3148695	3148772

EK-TRON 6.350 G-E

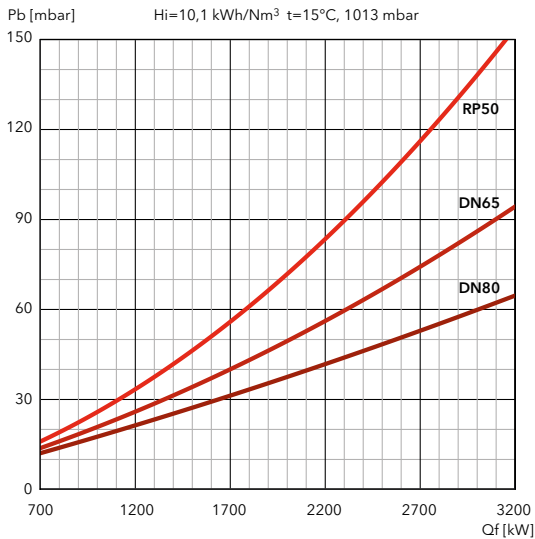

i Each gas train must be installed with its own **connection pipe**, to be selected from the following table:

Gas train model	Code	Connection pipe
GT-S1-VGD20-RP50-PS2	3148683	3144686
GT-S1-VGD40-DN65-PS2	3148684	3148771
GT-S1-VGD40-DN80-PS2	3148685	3148772
GT-D1-MBEVB-RP50-PS2	3148693	3144686
GT-D1-MBEVB-DN65-PS2	3148694	3148771
GT-D1-MBEVB-DN80-PS2	3148695	3148772

EK-TRON 6.400 G-E

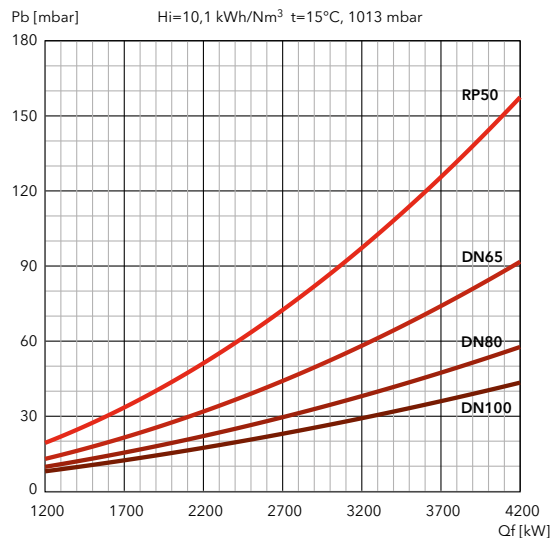

i Each gas train must be installed with its own **connection pipe**, to be selected from the following table:

Gas train model	Code	Connection pipe
GT-S1-VGD20-RP50-PS2	3148683	3148770
GT-S1-VGD40-DN65-PS2	3148684	3145997
GT-S1-VGD40-DN80-PS2	3148685	3145864
GT-S1-VGD40-DN100-PS2	3148686	3145821
GT-D1-MBEVB-RP50-PS2	3148693	3148770
GT-D1-MBEVB-DN65-PS2	3148694	3145997
GT-D1-MBEVB-DN80-PS2	3148695	3145864
GT-D1-MBEVB-DN100-PS2	3148696	3145821



PRESSURE LOSS [BURNER HEAD + GAS TRAIN] (mbar)

EK-TRON 7.500 G-E

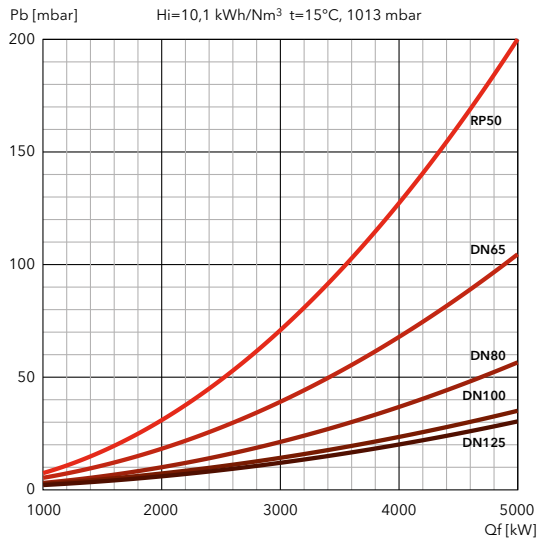

i Each gas train must be installed with its own **connection pipe**, to be selected from the following table:

Gas train model	Code	Connection pipe
GT-S1-VGD20-RP50-PS2	3148683	3148770
GT-S1-VGD40-DN65-PS2	3148684	3148766
GT-S1-VGD40-DN80-PS2	3148685	3148767
GT-S1-VGD40-DN100-PS2	3148686	3148768
GT-S1-VGD40-DN125-PS2	3148687	3148769
GT-D1-MBEVB-RP50-PS2	3148693	3148770
GT-D1-MBEVB-DN65-PS2	3148694	3148766
GT-D1-MBEVB-DN80-PS2	3148695	3148767
GT-D1-MBEVB-DN100-PS2	3148696	3148768

EK-TRON 7.600 G-E

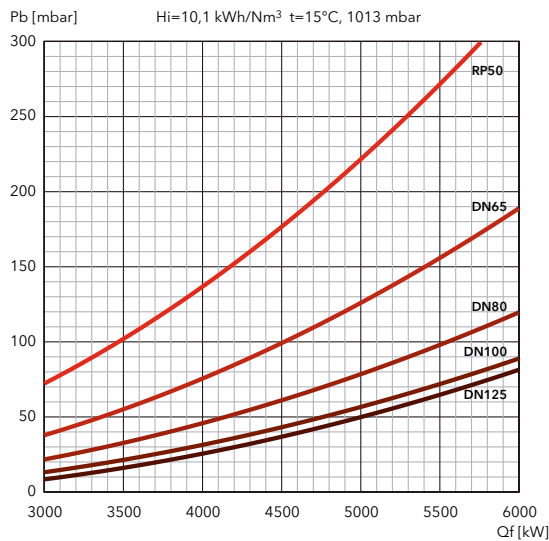

i Each gas train must be installed with its own **connection pipe**, to be selected from the following table:

Gas train model	Code	Connection pipe
GT-S1-VGD20-RP50-PS2	3148683	3148770
GT-S1-VGD40-DN65-PS2	3148684	3148766
GT-S1-VGD40-DN80-PS2	3148685	3148767
GT-S1-VGD40-DN100-PS2	3148686	3148768
GT-S1-VGD40-DN125-PS2	3148687	3148769
GT-D1-MBEVB-RP50-PS2	3148693	3148770
GT-D1-MBEVB-DN65-PS2	3148694	3148766
GT-D1-MBEVB-DN80-PS2	3148695	3148767
GT-D1-MBEVB-DN100-PS2	3148696	3148768

FILTERS

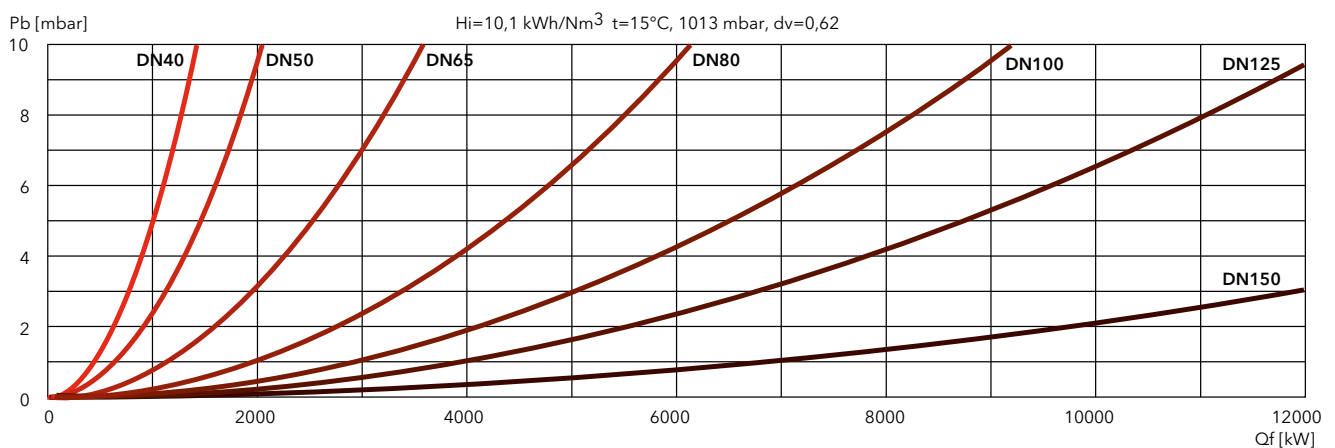

EK-TRON 5 G-R, EK-TRON 6 G-R, EK-TRON 7 G-R

340 ... 6050 kW

Two stage progressive/modulating mechanical



- **Fuel:** natural gas, Hi = 6,99 ... 11,39 kWh/Nm³
- **Emissions:** Low NOx class 2 burners (≤120 mg/kWh) according to EN676 Directive
- **Protection level:** IP 40

TECHNICAL DATA

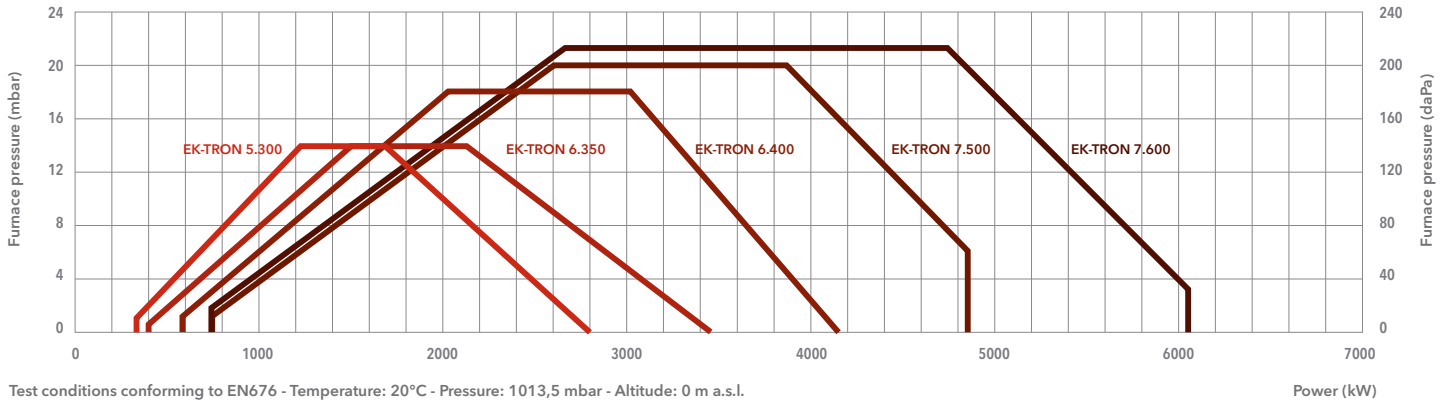

Test conditions conforming to EN676 - Temperature: 20°C - Pressure: 1013,5 mbar - Altitude: 0 m a.s.l.

	EK-TRON 5.300 G-R	EK-TRON 6.350 G-R	EK-TRON 6.400 G-R	EK-TRON 7.500 G-R	EK-TRON 7.600 G-R
Operating range	340 – 2800 kW	400 – 3450 kW	590 – 4150 kW	750 – 4850 kW	740 – 6050 kW
Gas connection	DN50	DN50	DN65	DN65	DN65
Control box / flame detector	LME73* / ionization	LME73* / ionization	LME73* / ionization	LME73* / ionization	LME73* / ionization
Auxiliary voltage	1NPE AC 230 V - 50 Hz TN-S	1NPE AC 230 V - 50 Hz TN-S	1NPE AC 230 V - 50 Hz TN-S	1NPE AC 230 V - 50 Hz TN-S	1NPE AC 230 V - 50 Hz TN-S
Power supply	3NPE AC 400 V - 50 Hz	3NPE AC 400 V - 50 Hz	3NPE AC 400 V - 50 Hz	3NPE AC 400 V - 50 Hz	3NPE AC 400 V - 50 Hz
Fan motor	4 kW	5,5 kW	7,5 kW	11 kW	15 kW
Acoustic level	<83 dB(A)	<84 dB(A)	<85 dB(A)	<85 dB(A)	<85 dB(A)
Burner codes (body + head)	KN	3148789	3148790	3148791	3148793
	KM	3148337	3148339	3148341	3148345
	KL	3148338	3148340	3148342	3148346

*: LME75 for 72H versions

OTHER AVAILABLE VERSIONS

Variant	EK-TRON 5.300 G-R	EK-TRON 6.350 G-R	EK-TRON 6.400 G-R	EK-TRON 7.500 G-R	EK-TRON 7.600 G-R
72H	KN	3148799	3148800	3148801	3148803
	KM	3148510	3148512	3148514	3148518
	KL	3148511	3148513	3148515	3148519

GAS TRAINS AND FILTERS

DUNGS models	Code	SIEMENS models	Code	Filters	Code
GT-D1-MBEVB-RP50-PS3	3148697	GT-S1-VGD20-RP50-PS3	3148688	FG-Rp2"	3757200
GT-D1-MBEVB-DN65-PS3	3148698	GT-S1-VGD40-DN65-PS3	3148689	FG-DN65	3757198
GT-D1-MBEVB-DN80-PS3	3148699	GT-S1-VGD40-DN80-PS3	3148690	FG-DN80	3757201
GT-D1-MBEVB-DN100-PS3	3148700	GT-S1-VGD40-DN100-PS3	3148691	FG-DN100	3757195
		GT-S1-VGD40-DN125-PS3	3148692	FG-DN125	3757209

DIMENSIONS (mm)

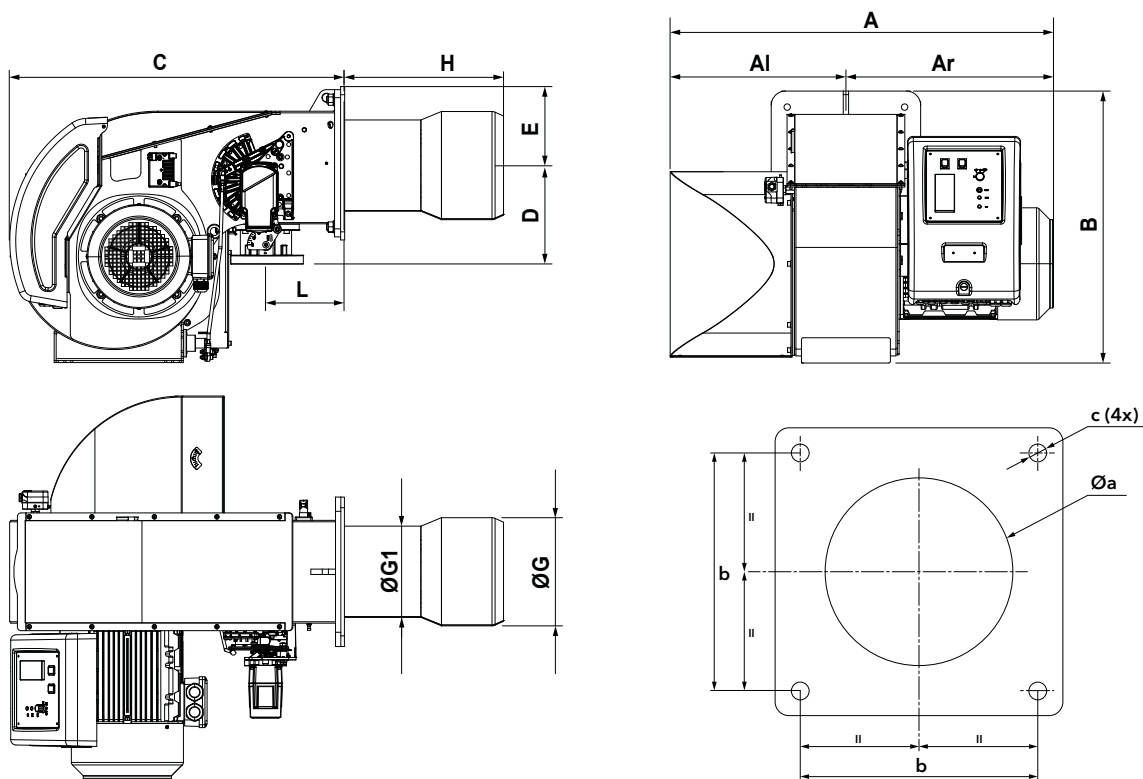

Model	A	AI	Ar	B	C	D	E	ØG	ØG1	H			L	Øa	b	c
										KN	KM	KL				
EK-TRON 5.300 G-R	813	356	457	606	714	245	190	300	216	385	485	585	125	315-325	315	M16
EK-TRON 6.350 G-R	875	387	488	684	828	245	190	290	240	328	428	528	195	305-315	315	M16
EK-TRON 6.400 G-R	875	387	488	684	828	250	190	320	270	392	448	563	195	335-345	315	M16
EK-TRON 7.500 G-R	1083	494	589	780	943	251	210	320	270	373	470	573	195	335-345	330	M16
EK-TRON 7.600 G-R	1083	494	589	780	943	251	210	360	270	373	470	573	195	375-385	330	M16

PACKAGING

The burner is delivered on a pallet with:

- burner body and combustion head (to be mounted by the installer)
- gas train and filter
- boiler fixing accessories
- technical documentation

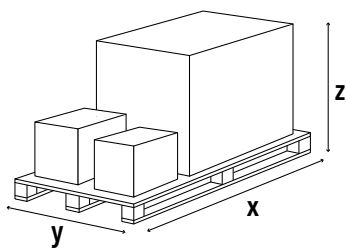

Model	Dimensions (mm)		
	X	Y	Z
EK-TRON 5.300 G-R	1100	900	720
EK-TRON 6.350 G-R	1100	900	720
EK-TRON 6.400 G-R	1100	900	720
EK-TRON 7.500 G-R	1300	1050	900
EK-TRON 7.600 G-R	1300	1050	900

EK-TRON 5 G-R, EK-TRON 6 G-R, EK-TRON 7 G-R

340 ... 6050 kW

Two stage progressive/modulating mechanical

PRESSURE LOSS [BURNER HEAD + GAS TRAIN] (mbar)

EK-TRON 5.300 G-R

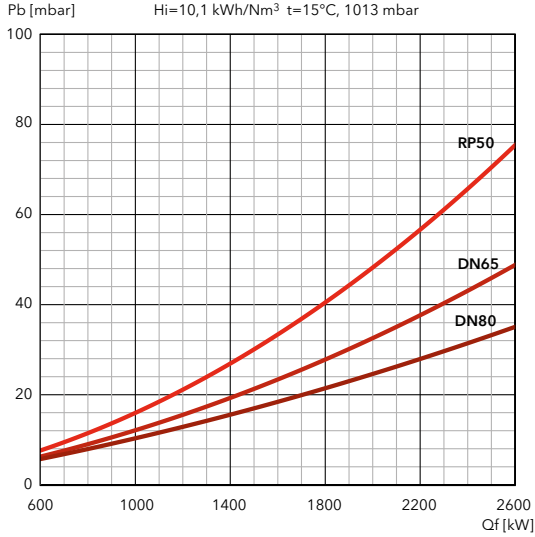

i Each gas train must be installed with its own **connection pipe**, to be selected from the following table:

Gas train model	Code	Connection pipe
GT-S1-VGD20-RP50-PS3	3148688	3144686
GT-S1-VGD40-DN65-PS3	3148689	3148771
GT-S1-VGD40-DN80-PS3	3148690	3148772
GT-D1-MBEVB-RP50-PS3	3148697	3144686
GT-D1-MBEVB-DN65-PS3	3148698	3148771
GT-D1-MBEVB-DN80-PS3	3148699	3148772

EK-TRON 6.350 G-R

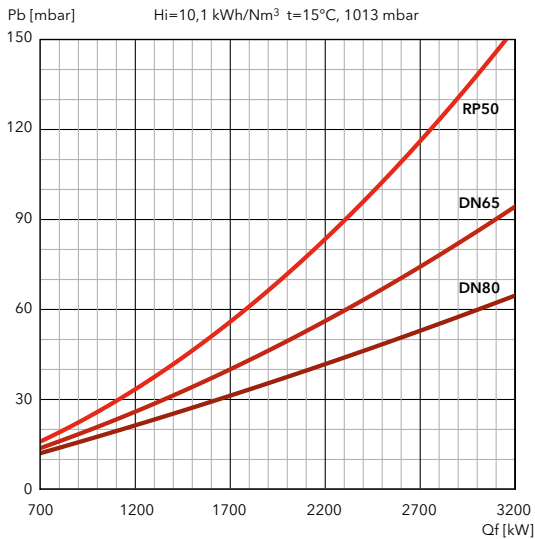

i Each gas train must be installed with its own **connection pipe**, to be selected from the following table:

Gas train model	Code	Connection pipe
GT-S1-VGD20-RP50-PS3	3148688	3144686
GT-S1-VGD40-DN65-PS3	3148689	3148771
GT-S1-VGD40-DN80-PS3	3148690	3148772
GT-D1-MBEVB-RP50-PS3	3148697	3144686
GT-D1-MBEVB-DN65-PS3	3148698	3148771
GT-D1-MBEVB-DN80-PS3	3148699	3148772

EK-TRON 6.400 G-R

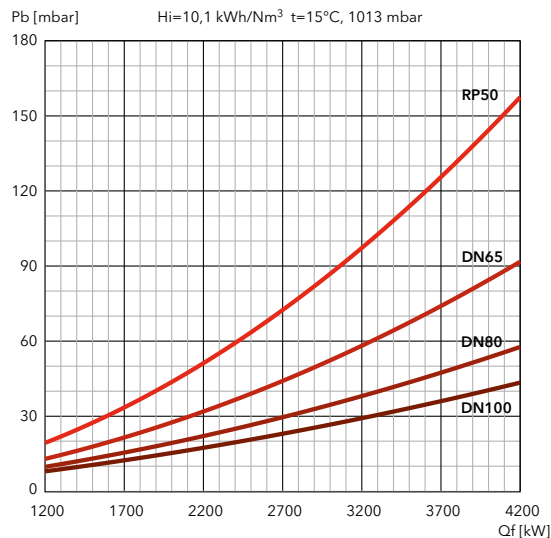

i Each gas train must be installed with its own **connection pipe**, to be selected from the following table:

Gas train model	Code	Connection pipe
GT-S1-VGD20-RP50-PS3	3148688	3148770
GT-S1-VGD40-DN65-PS3	3148689	3145997
GT-S1-VGD40-DN80-PS3	3148690	3145864
GT-S1-VGD40-DN100-PS3	3148691	3145821
GT-D1-MBEVB-RP50-PS3	3148697	3148770
GT-D1-MBEVB-DN65-PS3	3148698	3145997
GT-D1-MBEVB-DN80-PS3	3148699	3145864
GT-D1-MBEVB-DN100-PS3	3148700	3145821

PRESSURE LOSS [BURNER HEAD + GAS TRAIN] (mbar)

EK-TRON 7.500 G-R

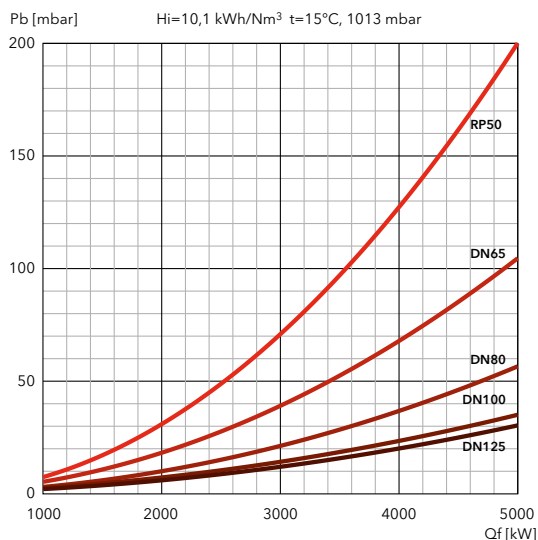

i Each gas train must be installed with its own **connection pipe**, to be selected from the following table:

Gas train model	Code	Connection pipe
GT-S1-VGD20-RP50-PS3	3148688	3148770
GT-S1-VGD40-DN65-PS3	3148689	3148766
GT-S1-VGD40-DN80-PS3	3148690	3148767
GT-S1-VGD40-DN100-PS3	3148691	3148768
GT-S1-VGD40-DN125-PS3	3148692	3148769
GT-D1-MBEVB-RP50-PS3	3148697	3148770
GT-D1-MBEVB-DN65-PS3	3148698	3148766
GT-D1-MBEVB-DN80-PS3	3148699	3148767
GT-D1-MBEVB-DN100-PS3	3148700	3148768

EK-TRON 7.600 G-R

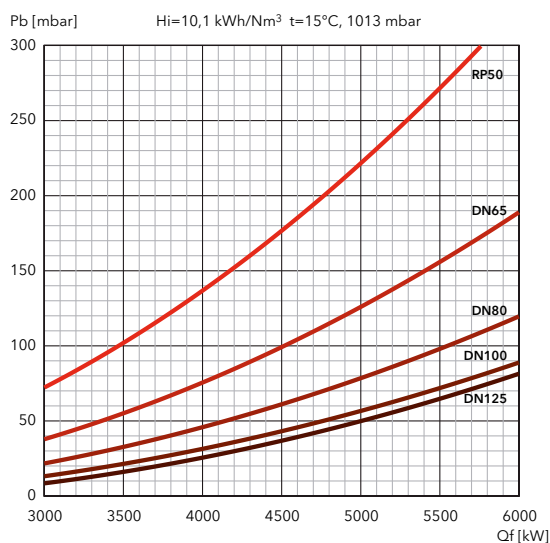

i Each gas train must be installed with its own **connection pipe**, to be selected from the following table:

Gas train model	Code	Connection pipe
GT-S1-VGD20-RP50-PS3	3148688	3148770
GT-S1-VGD40-DN65-PS3	3148689	3148766
GT-S1-VGD40-DN80-PS3	3148690	3148767
GT-S1-VGD40-DN100-PS3	3148691	3148768
GT-S1-VGD40-DN125-PS3	3148692	3148769
GT-D1-MBEVB-RP50-PS3	3148697	3148770
GT-D1-MBEVB-DN65-PS3	3148698	3148766
GT-D1-MBEVB-DN80-PS3	3148699	3148767
GT-D1-MBEVB-DN100-PS3	3148700	3148768

FILTERS

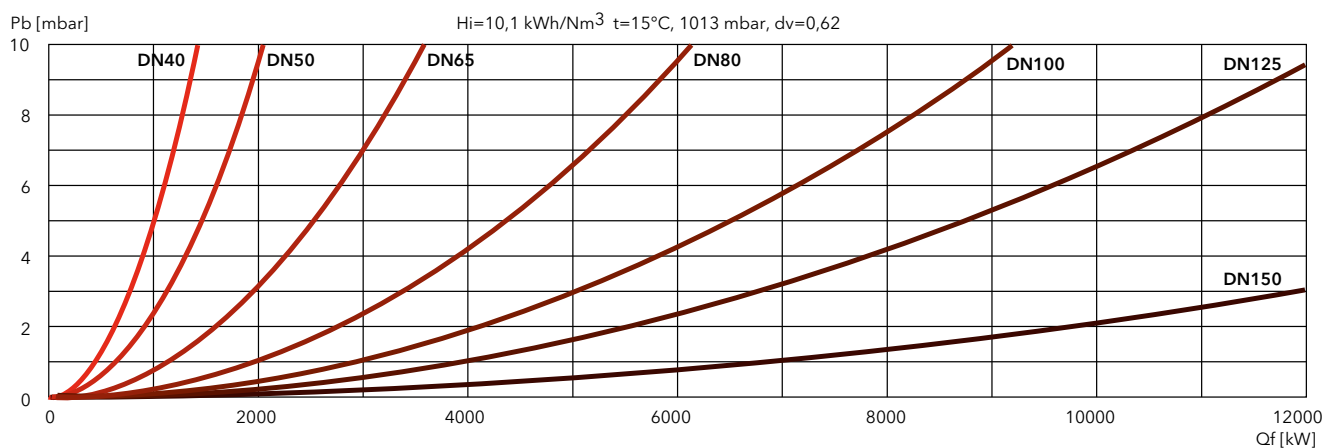

EK-TRON 6 FGR G-EX2

420 ... 3600 kW

Two stage progressive/modulating electronic



- **Fuel:** natural gas, Hi = 6,99 ... 11,39 kWh/Nm³
- **Emissions:** burners equipped with Low NOx Multi-Stage combustion head and with FGR System to reach Ultra Low NOx emissions (≤30 mg/kWh);
- **Protection level:** IP 40

TECHNICAL DATA

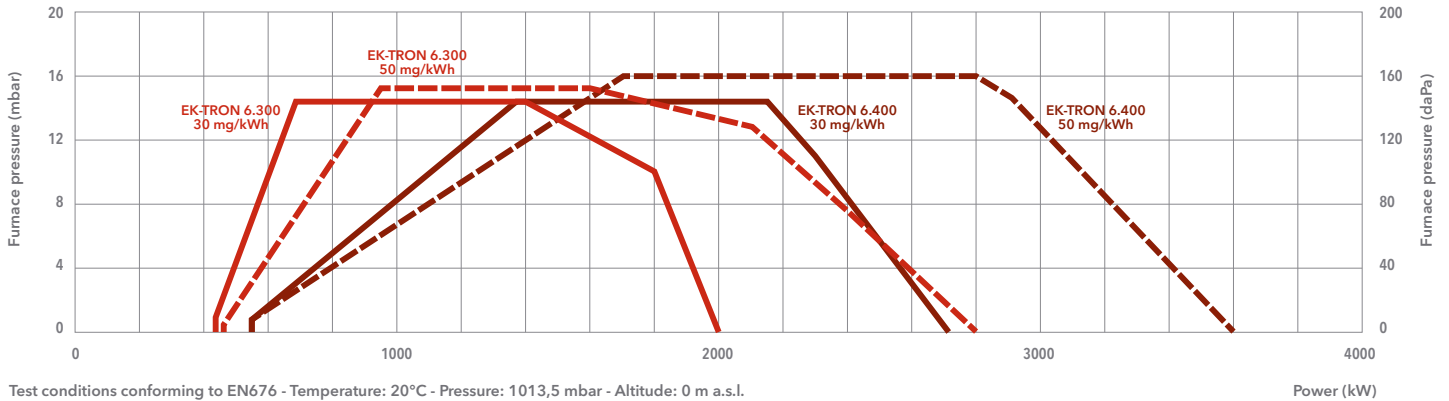

Test conditions conforming to EN676 - Temperature: 20°C - Pressure: 1013,5 mbar - Altitude: 0 m a.s.l.

	EK-TRON 6.300 FGR G-EX2		EK-TRON 6.400 FGR G-EX2	
	NOx < 30mg/Nm ³	NOx < 50mg/Nm ³	NOx < 30mg/Nm ³	NOx < 50mg/Nm ³
Operating range	420 - 2000 kW	460 - 2800 kW	560 - 2700 kW	560 - 3600 kW
Gas connection	DN50		DN65	
FGR connection	DN100		DN125	
Control box / flame detector	BT300 / Ionization		BT300 / Ionization	
Auxiliary voltage	1NPE AC 230 V - 50 Hz TN-S		1NPE AC 230 V - 50 Hz TN-S	
Power supply	3NPE AC 400 V - 50 Hz		3NPE AC 400 V - 50 Hz	
Fan motor	50 Hz - 5,5 kW		50 Hz - 7,5 kW	
Acoustic level	84 dB(A)		85 dB(A)	
Burner codes (body + head)	KM	3147118	3147120	
	KL	3147119	3147121	

GAS TRAINS AND FILTERS

DUNGS models	Code	SIEMENS models	Code	Filters	Code
GT-D1-MBEVB-RP50-PS2	3148693	GT-S1-VGD20-RP50-PS2	3148683	FG-Rp2"	3757200
GT-D1-MBEVB-DN65-PS2	3148694	GT-S1-VGD40-DN65-PS2	3148684	FG-DN65	3757198



DIMENSIONS (mm)

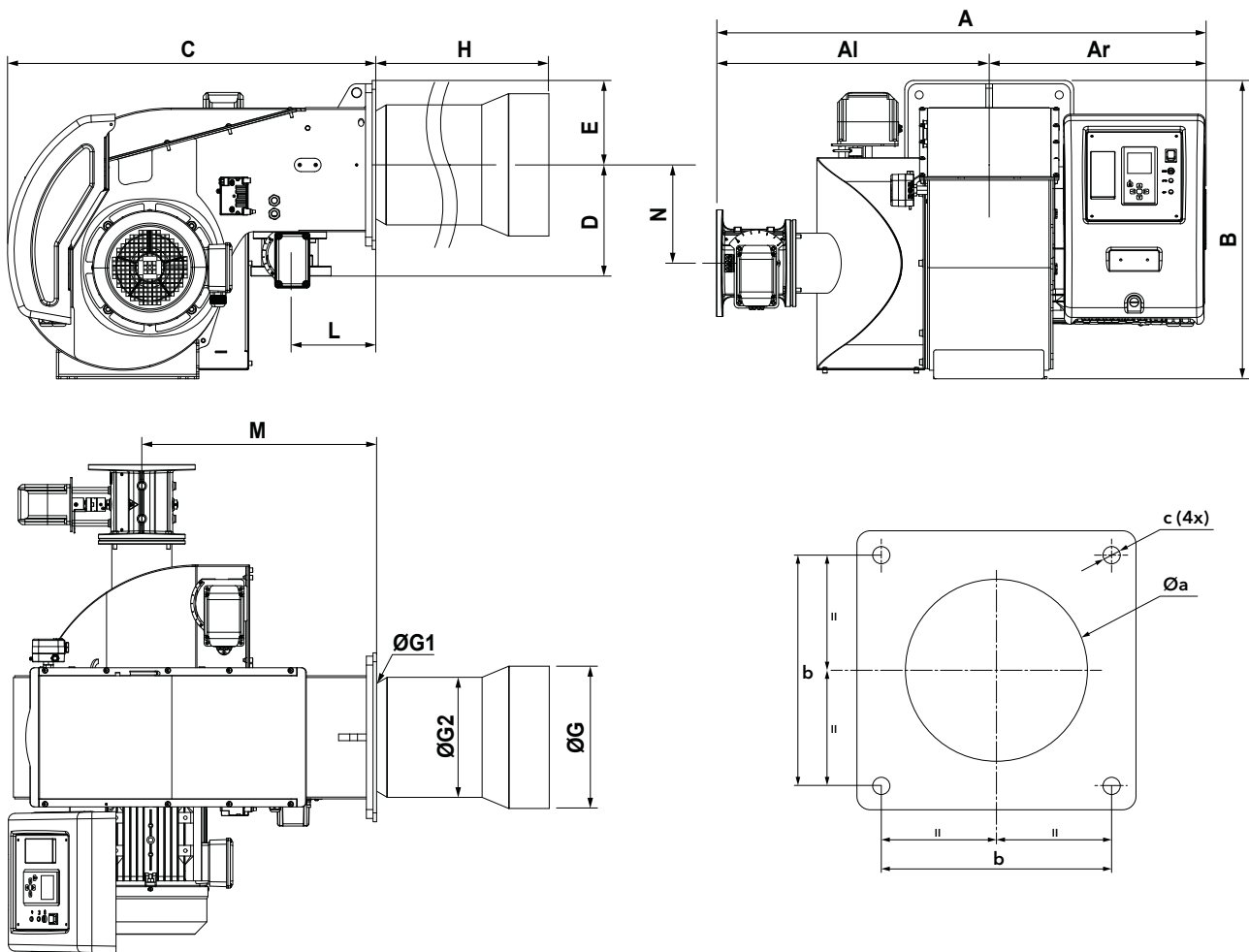

Model	A	Al	Ar	B	C	D	E	ØG	ØG1	ØG2	H		L	M	N	Øa	b	c
											KM	KL						
EK-TRON 6.300	1079	591	488	671	828	245	190	223	240	180	447	547	191	528	221	250-270	315	M16
EK-TRON 6.400	1100	612	488	671	828	250	190	320	240	270	387	487	191	528	221	330-350	315	M16

PACKAGING

The burner is delivered on a pallet with:

- burner body and combustion head (to be mounted by the installer)
- gas train and filter
- FGR valve
- boiler fixing accessories
- technical documentation

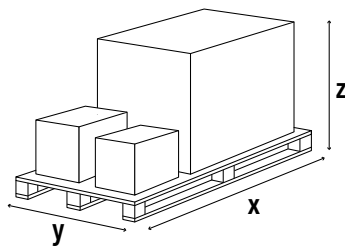

Model	Dimensions (mm)		
	X	Y	Z
EK-TRON 6.300	1100	900	720
EK-TRON 6.400	1100	900	720

EK-TRON 6 FGR G-EX2

420 ... 3600 kW

Two stage progressive/modulating electronic

PRESSURE LOSS [BURNER HEAD + GAS TRAIN] (mbar)

EK-TRON 6.300 FGR G-EX2

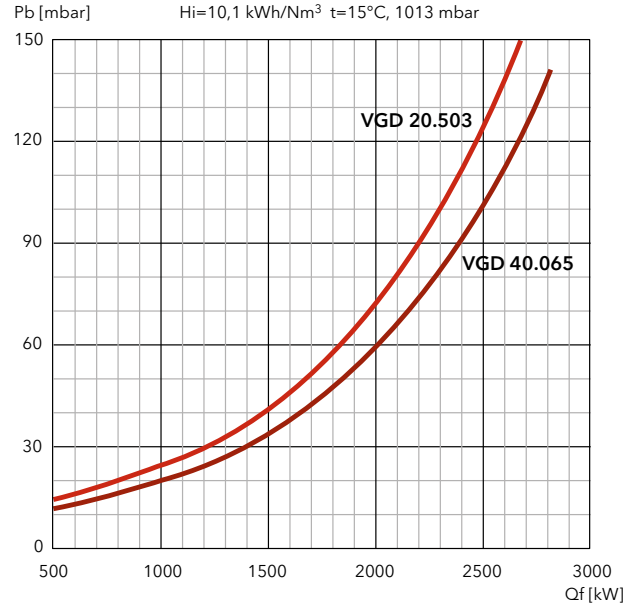
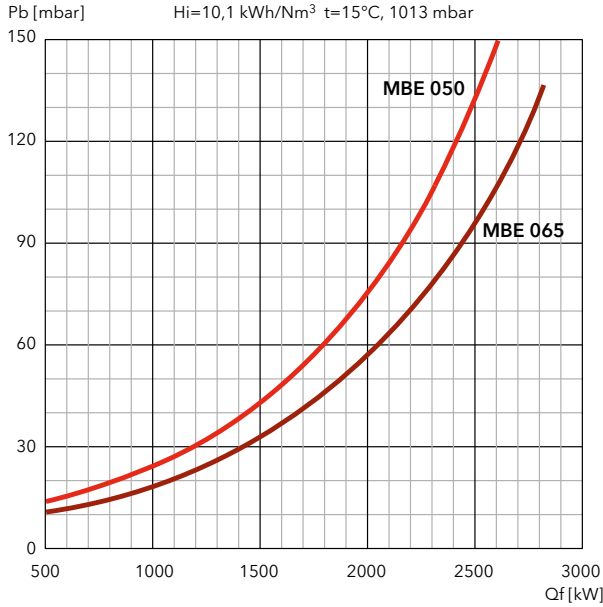

i Each gas train must be installed with its own **connection pipe**, to be selected from the following table:

Gas train model	Code	Connection pipe
GT-S1-VGD20-RP50-PS2	3148683	3144686
GT-S1-VGD40-DN65-PS2	3148684	3148771
GT-D1-MBEVB-RP50-PS2	3148693	3144686
GT-D1-MBEVB-DN65-PS2	3148694	3148771

FILTERS

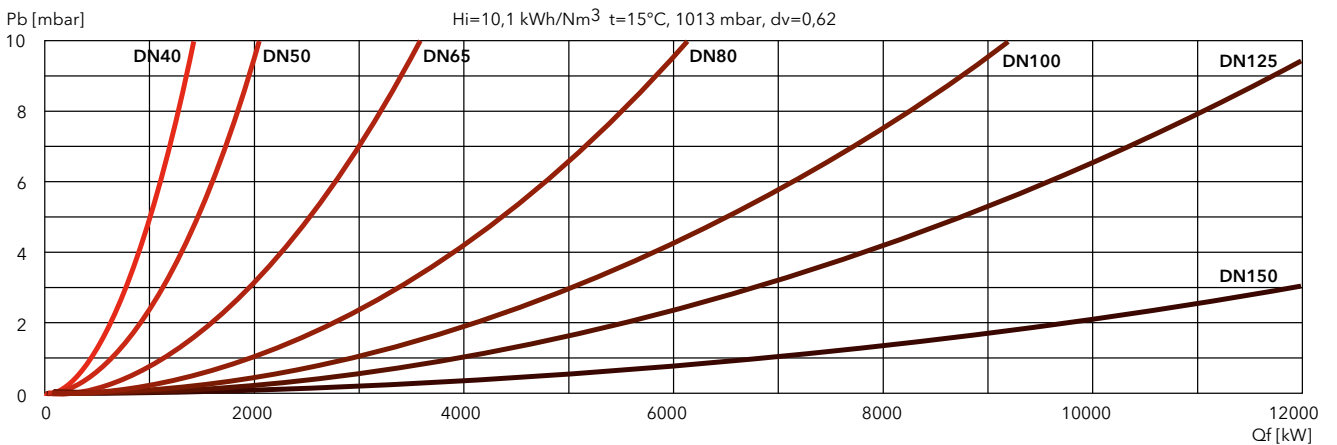



PRESSURE LOSS [BURNER HEAD + GAS TRAIN] (mbar)

EK-TRON 6.400 FGR G-EX2

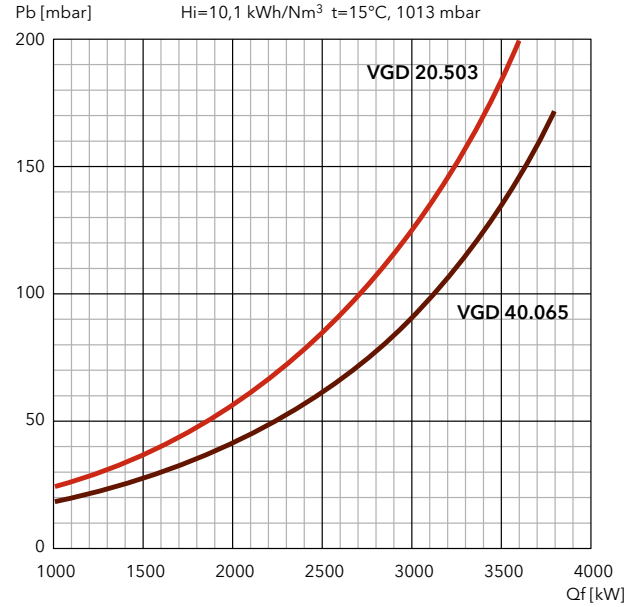
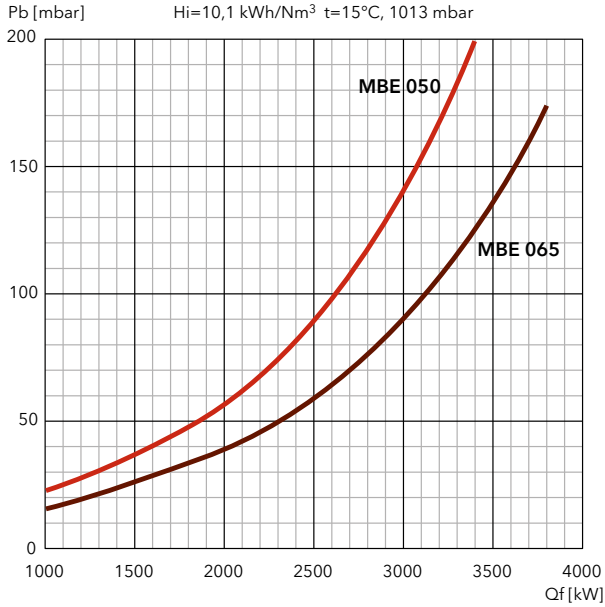

i Each gas train must be installed with its own **connection pipe**, to be selected from the following table:

Gas train model	Code	Connection pipe
GT-S1-VGD20-RP50-PS2	3148683	3148770
GT-S1-VGD40-DN65-PS2	3148684	3145997
GT-D1-MBEVB-RP50-PS2	3148693	3148770
GT-D1-MBEVB-DN65-PS2	3148694	3145997

FILTERS

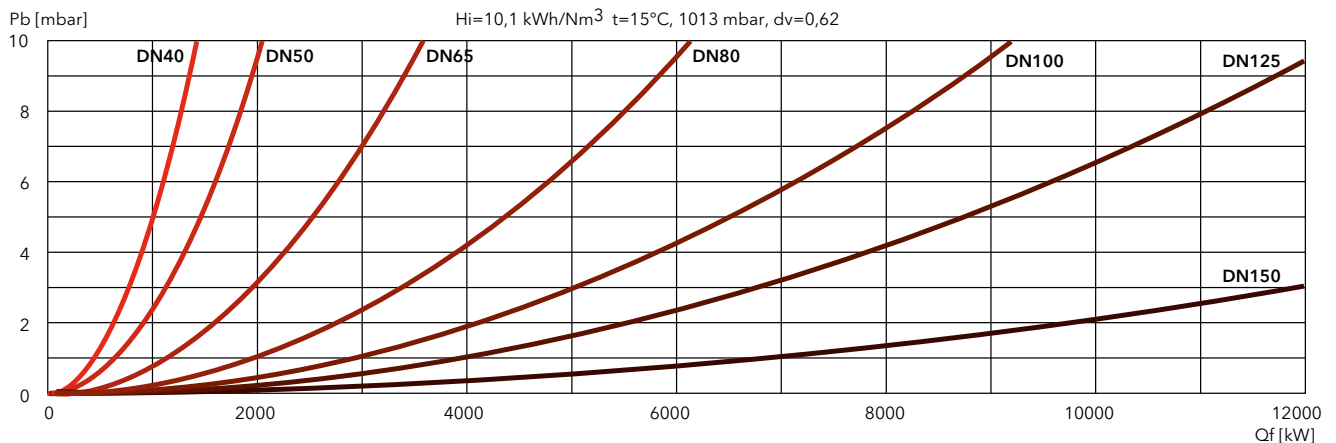

EK-TRON 7 FGR G-EF4

720 ... 4700 kW

Two stage progressive/modulating electronic



- **Fuel:** natural gas, Hi = 6,99 ... 11,39 kWh/Nm³
- **Emissions:** burners equipped with Low NOx Free Flame combustion head and with FGR System to reach Ultra Low NOx emissions (≤30 mg/kWh)
- **Protection level:** IP 40

TECHNICAL DATA

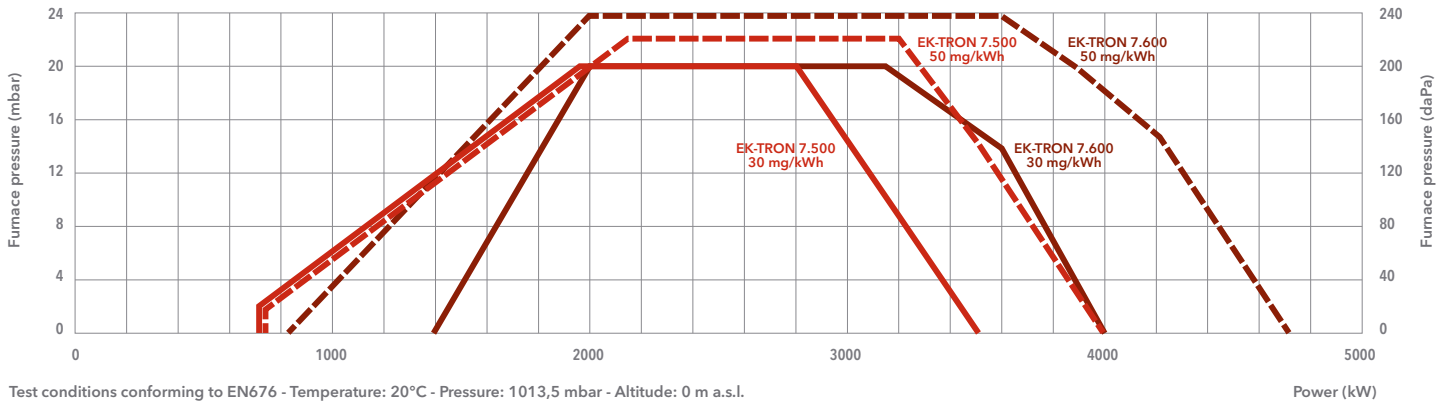

Test conditions conforming to EN676 - Temperature: 20°C - Pressure: 1013,5 mbar - Altitude: 0 m a.s.l.

	EK-TRON 7.500 FGR G-EF4		EK-TRON 7.600 FGR G-EF4	
	NOx < 30mg/Nm ³	NOx < 50mg/Nm ³	NOx < 30mg/Nm ³	NOx < 50mg/Nm ³
Operating range	720 - 3500 kW	750 - 4000 kW	1400 - 4000 kW	820 - 4700 kW
Gas connection	DN65		DN65	
FGR connection	DN150		DN150	
Control box / flame detector	BT300 / KLC		BT300 / KLC	
Auxiliary voltage	1NPE AC 230 V - 50 Hz TN-S		1NPE AC 230 V - 50 Hz TN-S	
Power supply	3NPE AC 400 V - 50 Hz		3NPE AC 400 V - 50 Hz	
Fan motor	50 Hz - 11 kW		50 Hz - 15 kW	
Acoustic level	84 dB(A)		85 dB(A)	
Burner codes (body + head)	KM	3147122	3147124	3147125
	KL	3147123	3147125	

GAS TRAINS AND FILTERS

DUNGS models	Code	SIEMENS models	Code	Filters	Code
GT-D1-MBEVB-RP50-PS2	3148693	GT-S1-VGD20-RP50-PS2	3148683	FG-Rp2"	3757200
GT-D1-MBEVB-DN65-PS2	3148694	GT-S1-VGD40-DN65-PS2	3148684	FG-DN65	3757198
GT-D1-MBEVB-DN80-PS2	3148695	GT-S1-VGD40-DN80-PS2	3148685	FG-DN80	3757201



DIMENSIONS (mm)

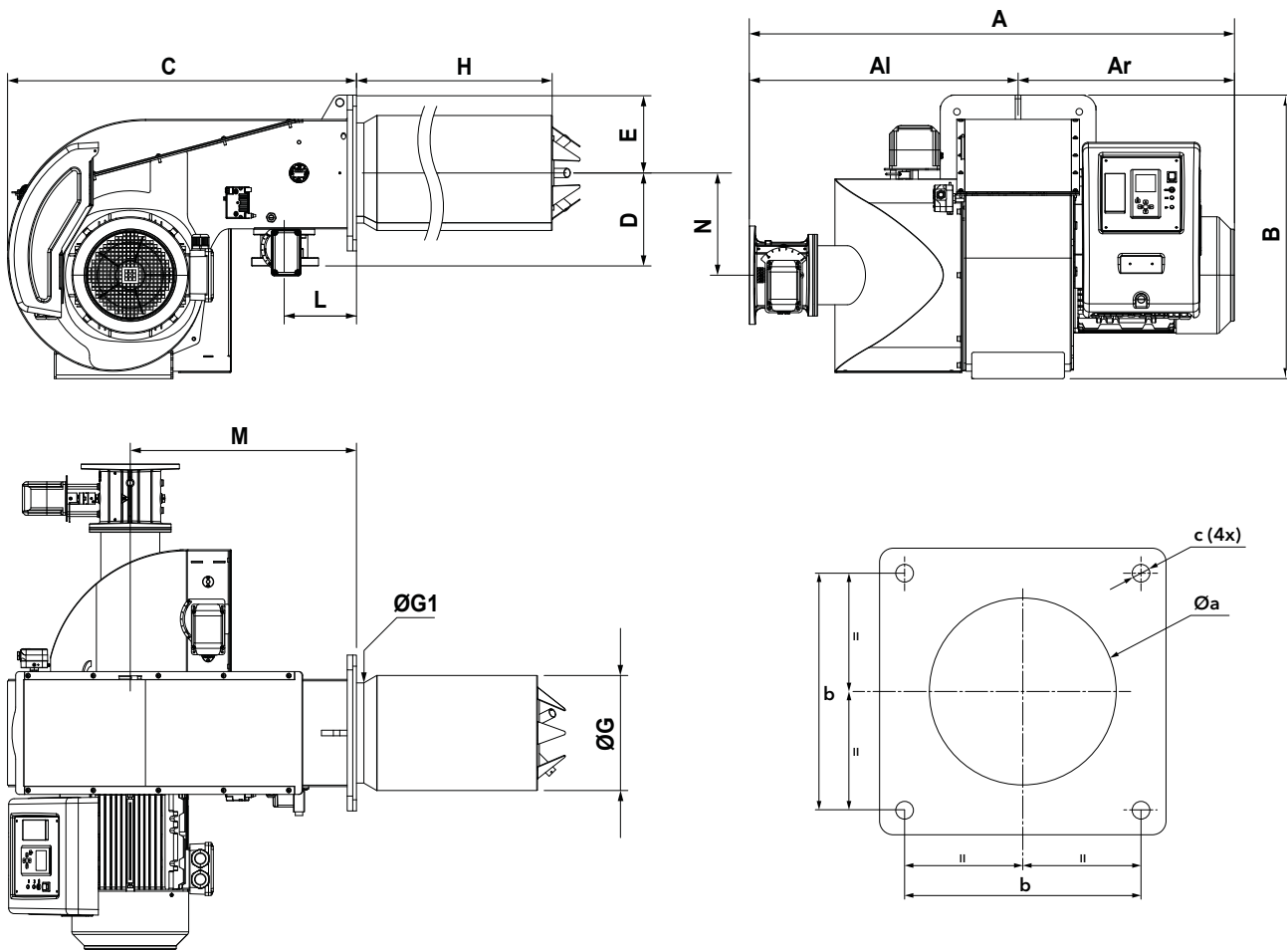

Model	A	Al	Ar	B	C	D	E	ØG	ØG1	H		L	M	N	Øa	b	c
										KM	KL						
EK-TRON 7.500	1309	725	584	764	941	251	210	310	270	558	688	195	610	251	330-350	330	M16
EK-TRON 7.600	1309	725	584	764	941	251	210	325	270	558	688	195	610	251	350-370	330	M16

PACKAGING

The burner is delivered on a pallet with:

- burner body and combustion head (to be mounted by the installer)
- gas train and filter
- FGR valve
- boiler fixing accessories
- technical documentation

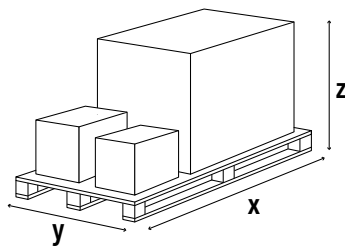

Model	Dimensions (mm)		
	X	Y	Z
EK-TRON 7.500	1300	1050	900
EK-TRON 7.600	1300	1050	900

EK-TRON 7 FGR G-EF4

720 ... 4700 kW

Two stage progressive/modulating electronic

PRESSURE LOSS [BURNER HEAD + GAS TRAIN] (mbar)

EK-TRON 7.500 FGR G-EF4

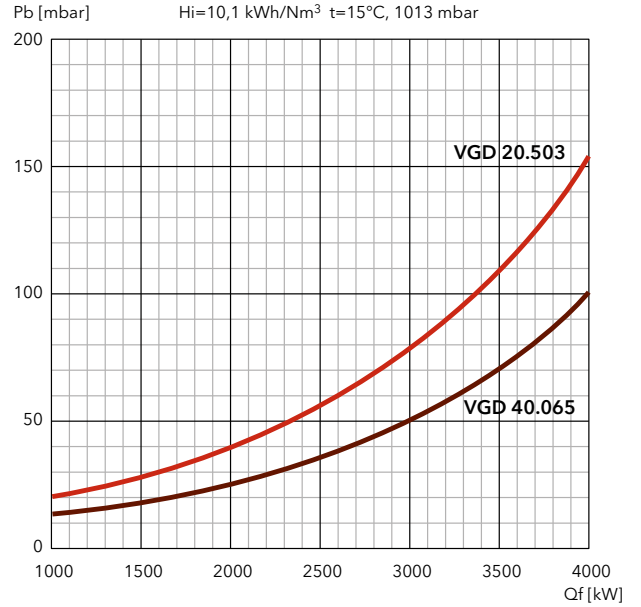
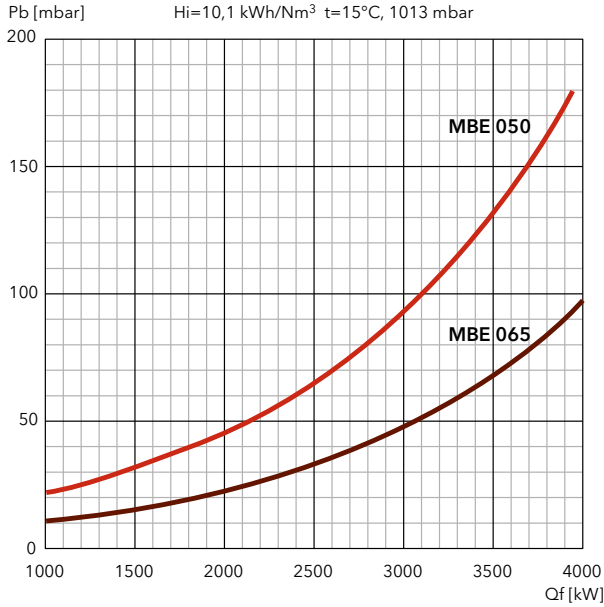

i Each gas train must be installed with its own **connection pipe**, to be selected from the following table:

Gas train model	Code	Connection pipe
GT-S1-VGD20-RP50-PS2	3148683	3148770
GT-S1-VGD40-DN65-PS2	3148684	3148766
GT-D1-MBEVB-RP50-PS2	3148693	3148770
GT-D1-MBEVB-DN65-PS2	3148694	3148766

FILTERS

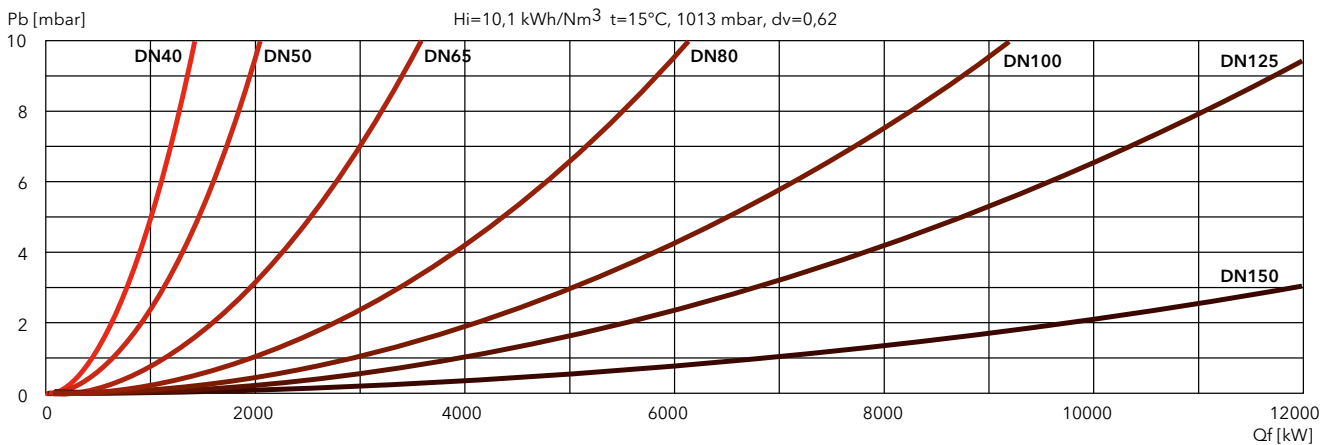



PRESSURE LOSS [BURNER HEAD + GAS TRAIN] (mbar)

EK-TRON 7.600 FGR G-EF4

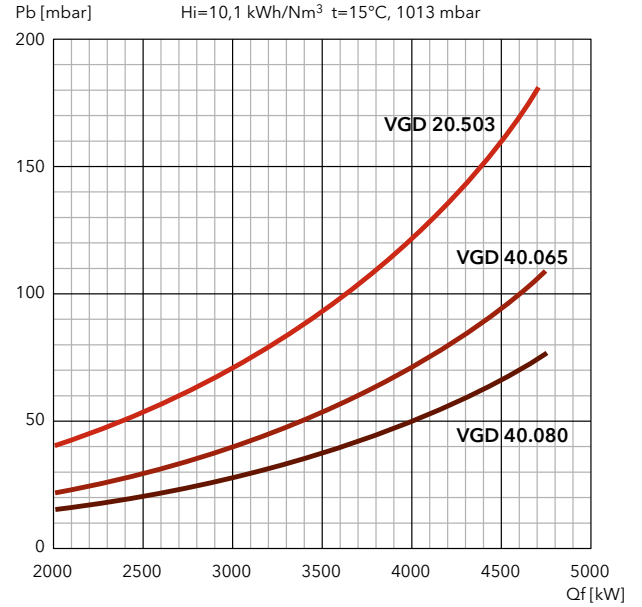
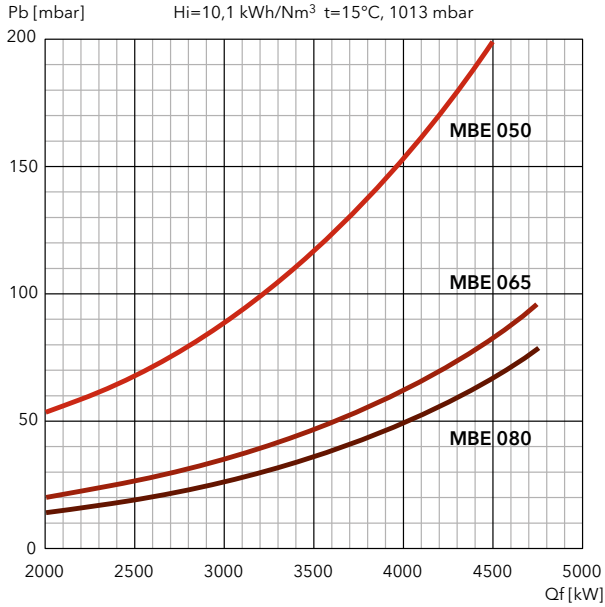

i Each gas train must be installed with its own **connection pipe**, to be selected from the following table:

Gas train model	Code	Connection pipe
GT-S1-VGD20-RP50-PS2	3148683	3148770
GT-S1-VGD40-DN65-PS2	3148684	3148766
GT-S1-VGD40-DN80-PS2	3148685	3148767
GT-D1-MBEVB-RP50-PS2	3148693	3148770
GT-D1-MBEVB-DN65-PS2	3148694	3148766
GT-D1-MBEVB-DN80-PS2	3148695	3148767

FILTERS

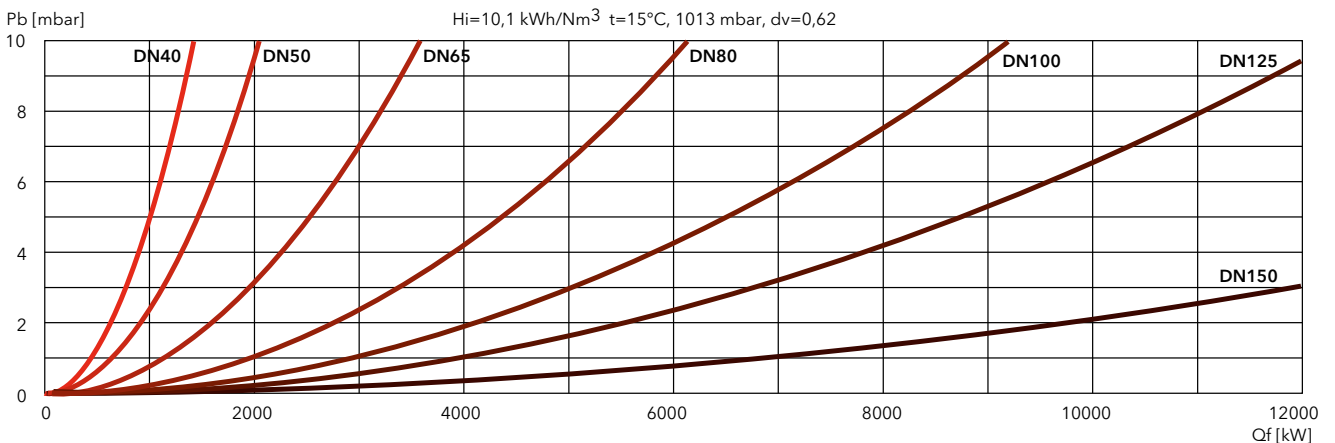

EK-TRON 5 GL-EX2

320 ... 2160 kW

Two stage progressive/modulating electronic



- **Fuels:** natural gas, Hi = 6,99 ... 11,39 kWh/Nm³
light oil, viscosity 6 mm²/s at 20°C, Hi = 11,86 kWh/kg
- **Emissions:** Low NOx class 3 (≤80 mg/kWh) according to EN676 in gas
Low NOx class 2 (≤185 mg/kWh) according to EN267 in light oil
- **Protection level:** IP 40

TECHNICAL DATA

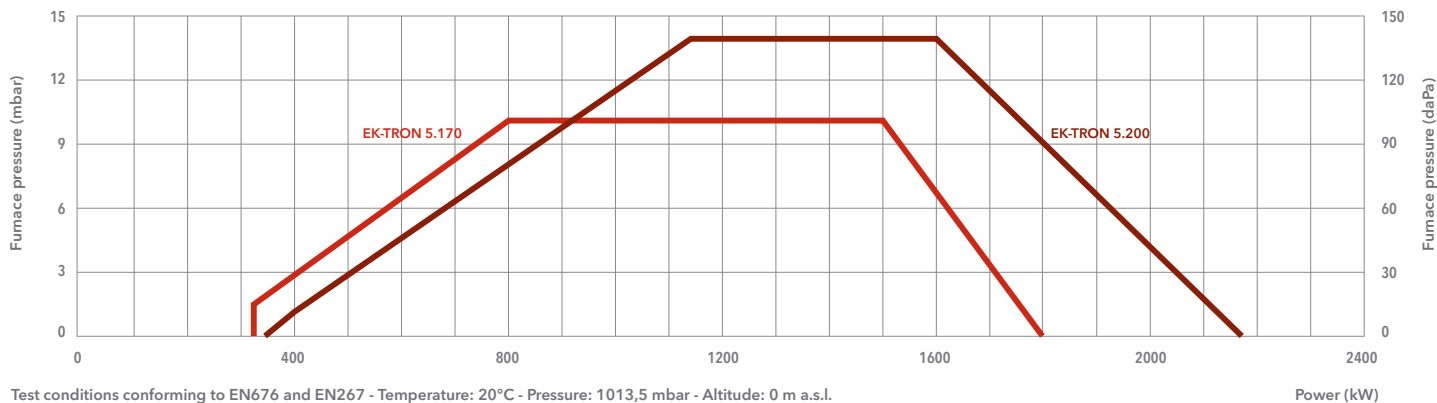

Test conditions conforming to EN676 and EN267 - Temperature: 20°C - Pressure: 1013,5 mbar - Altitude: 0 m a.s.l.

		EK-TRON 5.170 GL-EX2	EK-TRON 5.200 GL-EX2
Operating range		320 - 1800 kW	340 - 2160 kW
Gas connection		DN50	DN50
Control box / flame detector		BT335 / UV cell	BT335 / UV cell
Auxiliary voltage		1NPE AC 230 V - 50 Hz TN-S	1NPE AC 230 V - 50 Hz TN-S
Power supply		3NPE AC 400 V - 50 Hz	3NPE AC 400 V - 50 Hz
Fan motor		50 Hz - 3 kW	50 Hz - 4 kW
Acoustic level		< 75 dB(A)	< 80 dB(A)
Burner codes (body + head)	KN	3149001	3149003
	KL	3149002	3149004

OTHER AVAILABLE VERSIONS

Variant		EK-TRON 5.170 GL-EX2	EK-TRON 5.200 GL-EX2
72H	KM	3149105	3149107
	KL	3149106	3149108
FCE	KM	3149119	3149121
	KL	3149120	3149122
72H + FCE	KM	3149133	3149135
	KL	3149134	3149136
FCO	KM	3149147	3149149
	KL	3149148	3149150
72H + FCO	KM	3149161	3149163
	KL	3149162	3149164

GAS TRAINS AND FILTERS

DUNGS models	Code	SIEMENS models	Code	Filters	Code
GT-D1-MBDLE415-RP40-PS2	3149611	GT-S1-VGD20-RP50-PS2	3148683	FG-Rp1"1/2	3757199
GT-D1-MBDLE420-RP50-PS2	3149612	GT-S1-VGD40-DN65-PS2	3148684	FG-Rp2"	3757200
		GT-S1-VGD40-DN80-PS2	3148685	FG-DN65	3757198
				FG-DN80	3757201



DIMENSIONS (mm)

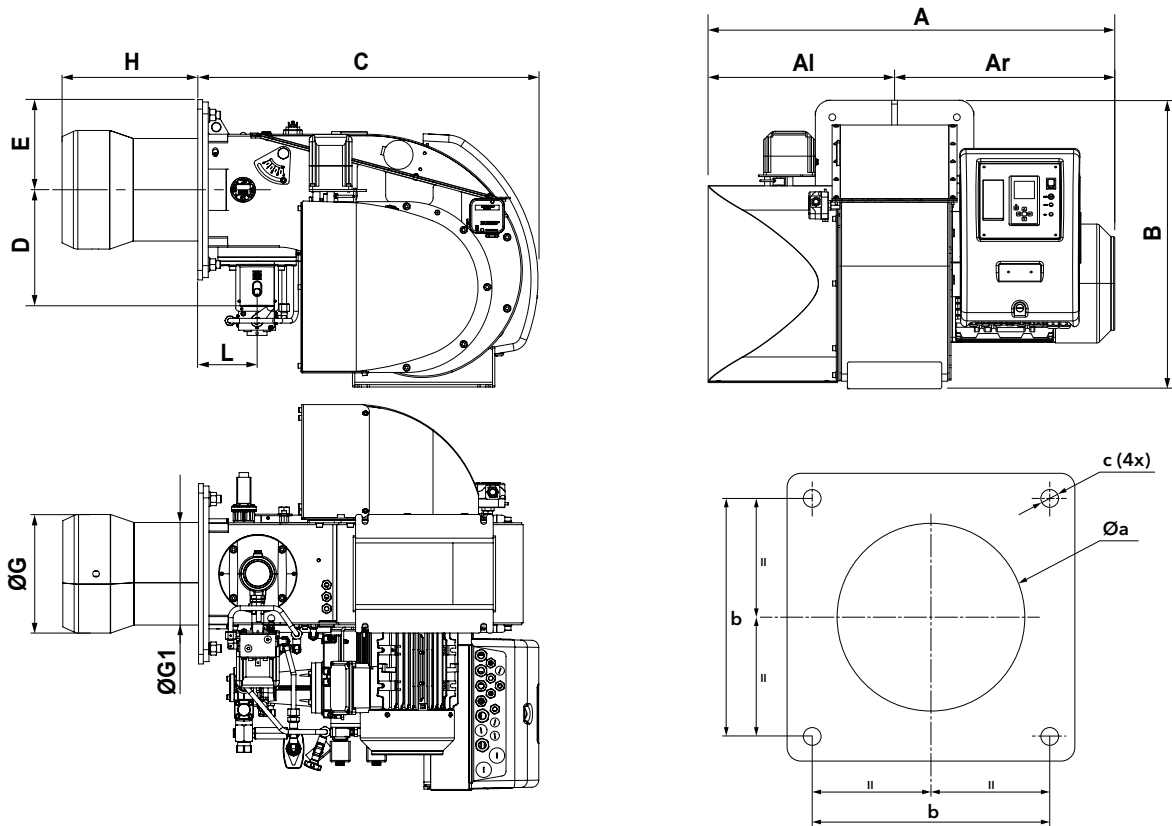

Model	A	Al	Ar	B	C	D	E	ØG	ØG1	H		L	Øa	b	c
										KN	KL				
EK-TRON 5.170	813	356	457	606	717	245	190	250	216	286	486	125	265-275	315	M16
EK-TRON 5.200	813	356	457	606	717	245	190	270	216	286	486	125	265-275	315	M16

PACKAGING

The burner is delivered on a pallet with:

- burner body and combustion head (to be mounted by the installer)
- gas train and filter
- boiler fixing accessories
- technical documentation

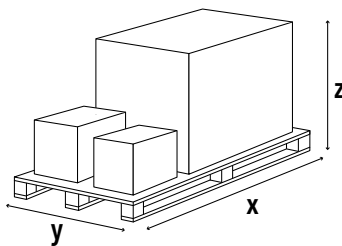

Model	Dimensions (mm)		
	X	Y	Z
EK-TRON 5.170	1100	900	720
EK-TRON 5.200	1100	900	720

i Nozzles not included, to be added in case of order: see page 51

EK-TRON 5 GL-EX2

320 ... 2160 kW

Two stage progressive/modulating electronic

PRESSURE LOSS [BURNER HEAD + GAS TRAIN] (mbar)

EK-TRON 5.170 GL-EX2

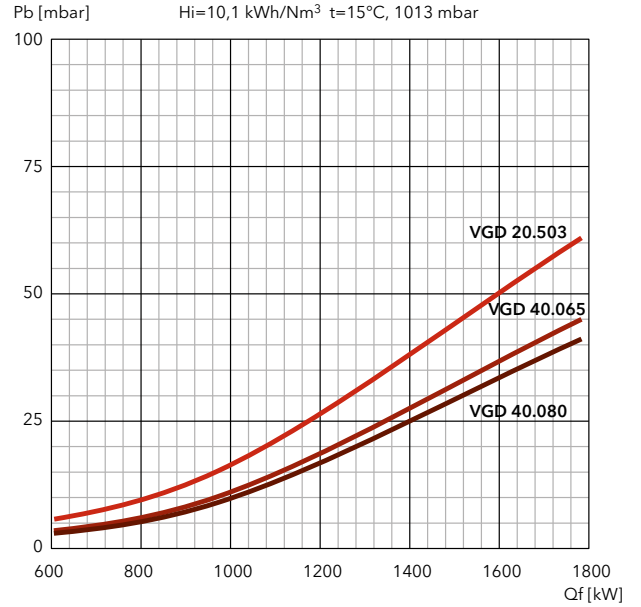
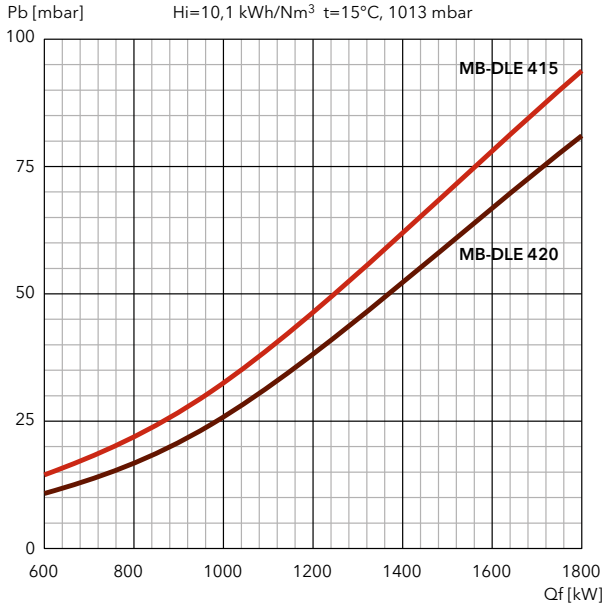

i Each gas train must be installed with its own **connection pipe**, to be selected from the following table:

Gas train model	Code	Connection pipe
GT-D1-MBDLE415-RP40-PS2	3149611	3144686
GT-D1-MBDLE420-RP50-PS2	3149612	3144686
GT-S1-VGD20-RP50-PS2	3148683	3144686
GT-S1-VGD40-DN65-PS2	3148684	3148771
GT-S1-VGD40-DN80-PS2	3148685	3148772

FILTERS

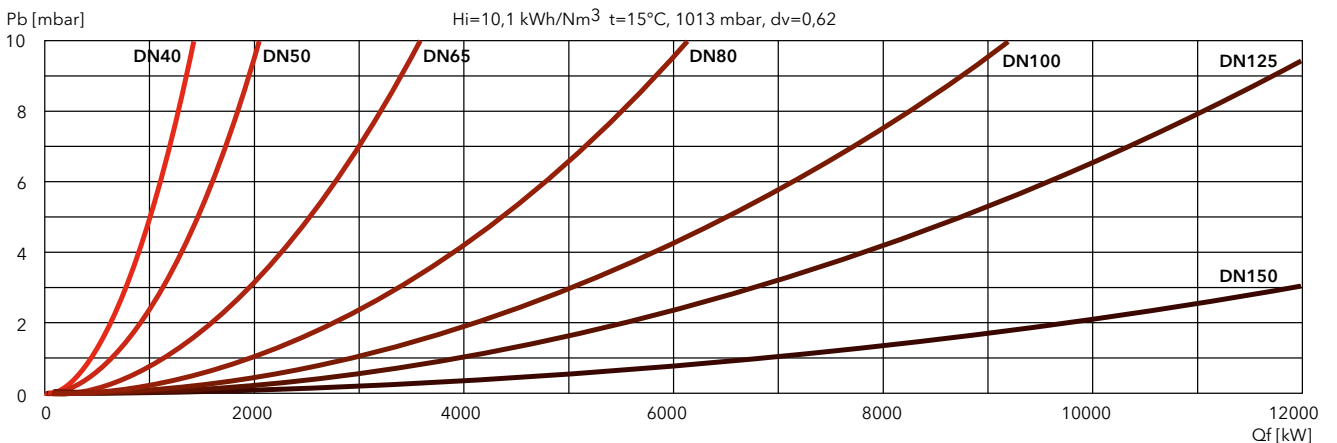



PRESSURE LOSS [BURNER HEAD + GAS TRAIN] (mbar)

EK-TRON 5.200 GL-EX2

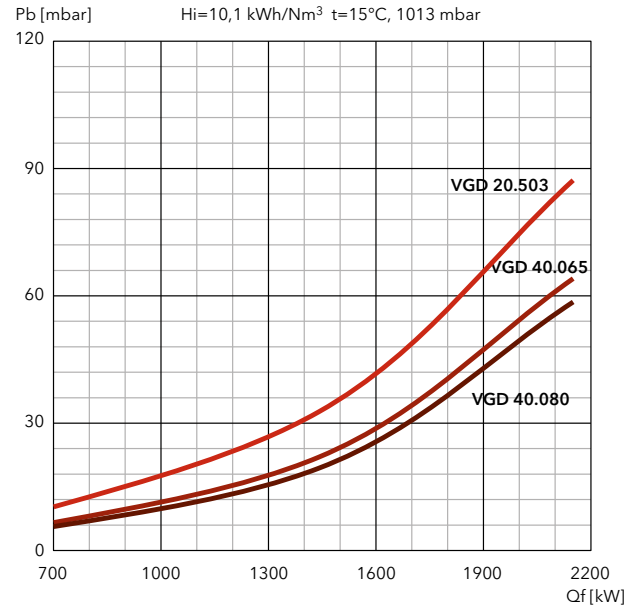
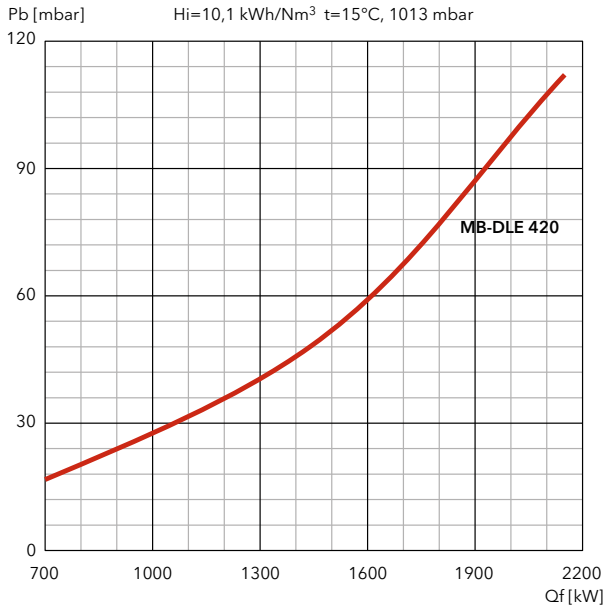

i Each gas train must be installed with its own **connection pipe**, to be selected from the following table:

Gas train model	Code	Connection pipe
GT-D1-MBDLE420-RP50-PS2	3149612	3144686
GT-S1-VGD20-RP50-PS2	3148683	3144686
GT-S1-VGD40-DN65-PS2	3148684	3148771
GT-S1-VGD40-DN80-PS2	3148685	3148772

FILTERS

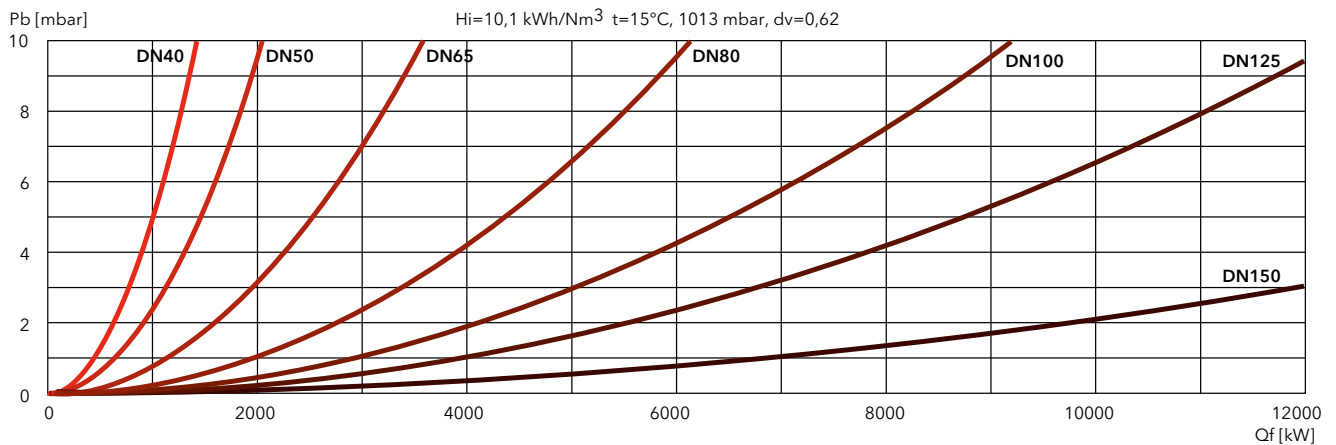

EK-TRON 6 GL-EX2

600 ... 3900 kW

Two stage progressive/modulating electronic



- **Fuels:** natural gas, Hi = 6,99 ... 11,39 kWh/Nm³
light oil, viscosity 6 mm²/s at 20°C, Hi = 11,86 kWh/kg
- **Emissions:** Low NOx class 3 (≤80 mg/kWh) according to EN676 in gas
Low NOx class 2 (≤185 mg/kWh) according to EN267 in light oil
- **Protection level:** IP 40

TECHNICAL DATA

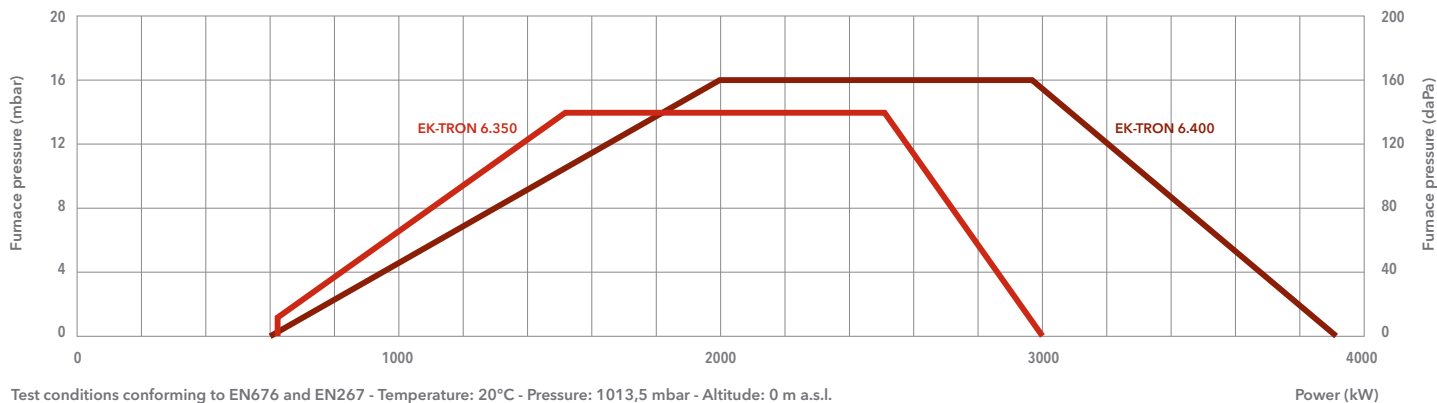

Test conditions conforming to EN676 and EN267 - Temperature: 20°C - Pressure: 1013,5 mbar - Altitude: 0 m a.s.l.

	EK-TRON 6.350 GL-EX2	EK-TRON 6.400 GL-EX2								
Operating range	610 – 3200 kW	600 – 3900 kW								
Gas connection	DN50	DN65								
Control box / flame detector	BT335 / KLC20	BT335 / KLC20								
Auxiliary voltage	1NPE AC 230 V - 50 Hz TN-S	1NPE AC 230 V - 50 Hz TN-S								
Power supply	3NPE AC 400 V - 50 Hz	3NPE AC 400 V - 50 Hz								
Fan motor	50 Hz - 5,5 kW	50 Hz - 7,5 kW								
Acoustic level	< 84 dB(A)	< 85 dB(A)								
Burner codes (body + head)	<table border="0"> <tr> <td>KN</td> <td>3149007</td> </tr> <tr> <td>KL</td> <td>3149008</td> </tr> </table>	KN	3149007	KL	3149008	<table border="0"> <tr> <td>KN</td> <td>3149009</td> </tr> <tr> <td>KL</td> <td>3149010</td> </tr> </table>	KN	3149009	KL	3149010
KN	3149007									
KL	3149008									
KN	3149009									
KL	3149010									

OTHER AVAILABLE VERSIONS

Variant		EK-TRON 6.350 GL-EX2	EK-TRON 6.400 GL-EX2
72H	KN	3149111	3149112
	KL	3149113	3149114
FCE	KN	3149125	3149126
	KL	3149127	3149128
72H + FCE	KN	3149139	3149140
	KL	3149141	3149142
FCO	KN	3149153	3149154
	KL	3149155	3149156
72H + FCO	KN	3149167	3149168
	KL	3149169	3149170

GAS TRAINS AND FILTERS

DUNGS models	Code	SIEMENS models	Code	Filters	Code
GT-D1-MBEVB-RP50-PS2	3148693	GT-S1-VGD20-RP50-PS2	3148683	FG-Rp2"	3757200
GT-D1-MBEVB-DN65-PS2	3148694	GT-S1-VGD40-DN65-PS2	3148684	FG-DN65	3757198
GT-D1-MBEVB-DN80-PS2	3148695	GT-S1-VGD40-DN80-PS2	3148685	FG-DN80	3757201
GT-D1-MBEVB-DN100-PS2	3148696	GT-S1-VGD40-DN100-PS2	3148686	FG-DN100	3757195



DIMENSIONS (mm)

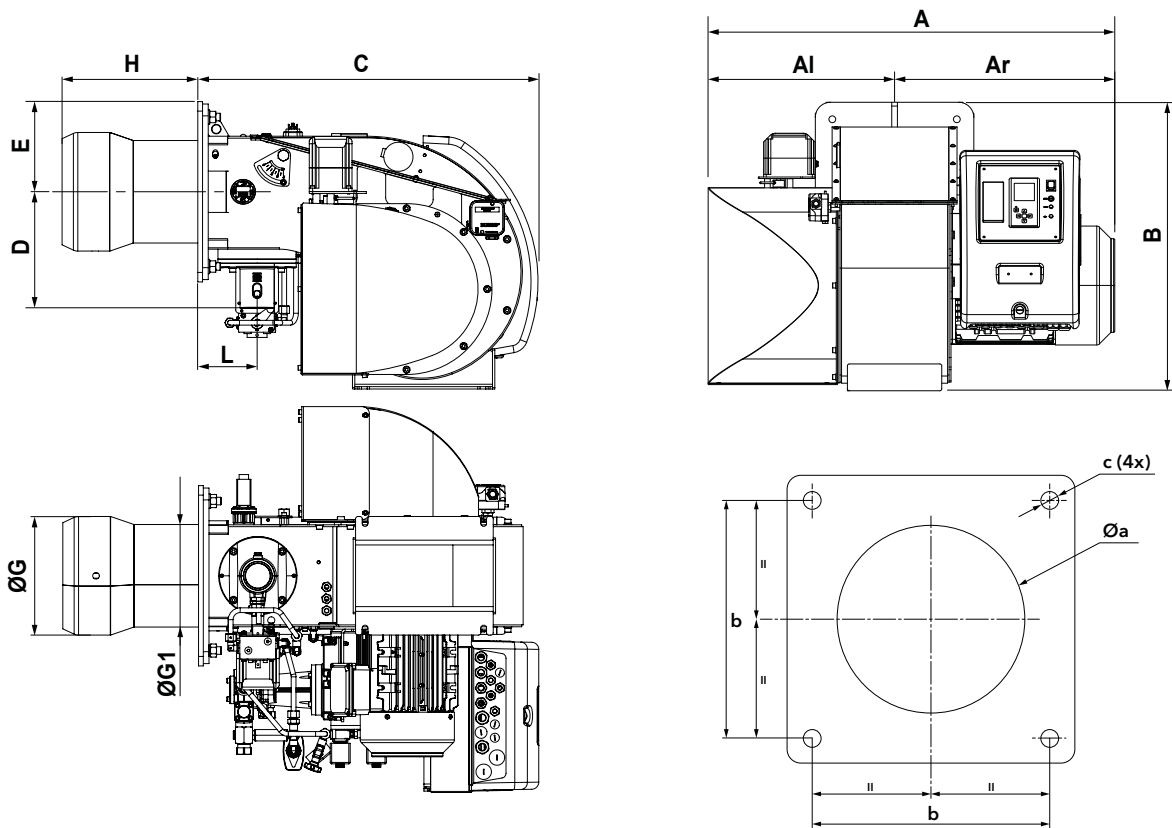

Model	A	Al	Ar	B	C	D	E	ØG	ØG1	H		L	Øa	b	c
										KN	KL				
EK-TRON 6.350	876	388	488	684	830	245	190	290	241	328	528	195	305-315	315	M16
EK-TRON 6.400	876	388	488	684	830	250	190	320	270	344	544	195	335-345	315	M16

PACKAGING

The burner is delivered on a pallet with:

- burner body and combustion head (to be mounted by the installer)
- gas train and filter
- boiler fixing accessories
- technical documentation

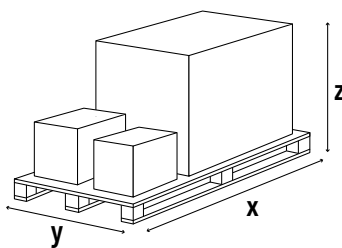

Model	Dimensions (mm)		
	X	Y	Z
EK-TRON 6.350	1100	900	720
EK-TRON 6.400	1100	900	720

i Nozzles not included, to be added in case of order: see page 51

EK-TRON 6 GL-EX2

600 ... 3900 kW

Two stage progressive/modulating electronic

PRESSURE LOSS [BURNER HEAD + GAS TRAIN] (mbar)

EK-TRON 6.350 GL-EX2

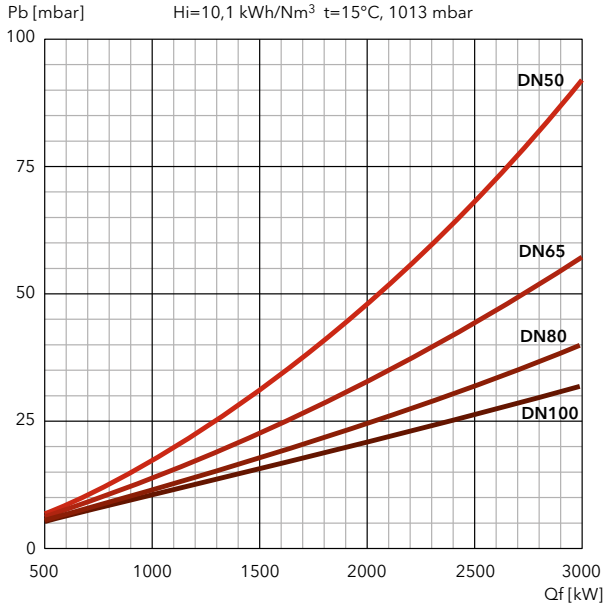

i Each gas train must be installed with its own **connection pipe**, to be selected from the following table:

Gas train model	Code	Connection pipe
GT-S1-VGD20-RP50-PS2	3148683	3144686
GT-S1-VGD40-DN65-PS2	3148684	3148771
GT-S1-VGD40-DN80-PS2	3148685	3148772
GT-S1-VGD40-DN100-PS2	3148686	3148773
GT-D1-MBEVB-RP50-PS2	3148693	3144686
GT-D1-MBEVB-DN65-PS2	3148694	3148771
GT-D1-MBEVB-DN80-PS2	3148695	3148772
GT-D1-MBEVB-DN100-PS2	3148696	3148773

FILTERS

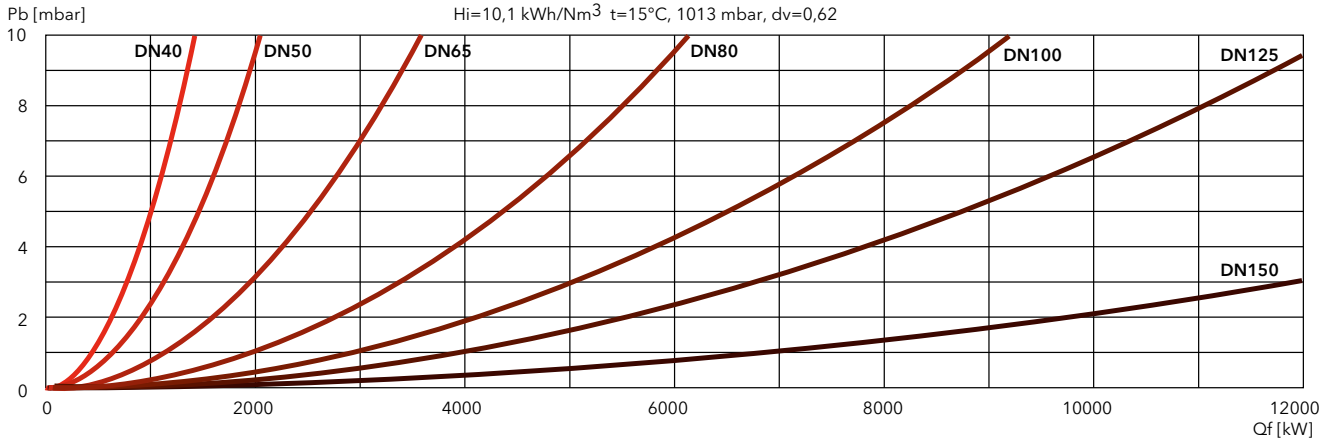



PRESSURE LOSS [BURNER HEAD + GAS TRAIN] (mbar)

EK-TRON 6.400 GL-EX2

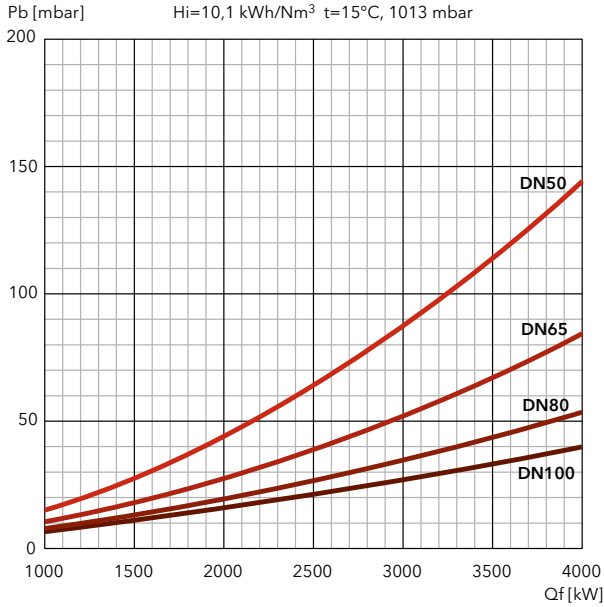

i Each gas train must be installed with its own **connection pipe**, to be selected from the following table:

Gas train model	Code	Connection pipe
GT-S1-VGD20-RP50-PS2	3148683	3148770
GT-S1-VGD40-DN65-PS2	3148684	3148766
GT-S1-VGD40-DN80-PS2	3148685	3148767
GT-S1-VGD40-DN100-PS2	3148686	3148768
GT-D1-MBEVB-RP50-PS2	3148693	3148770
GT-D1-MBEVB-DN65-PS2	3148694	3148766
GT-D1-MBEVB-DN80-PS2	3148695	3148767
GT-D1-MBEVB-DN100-PS2	3148696	3148768

FILTERS

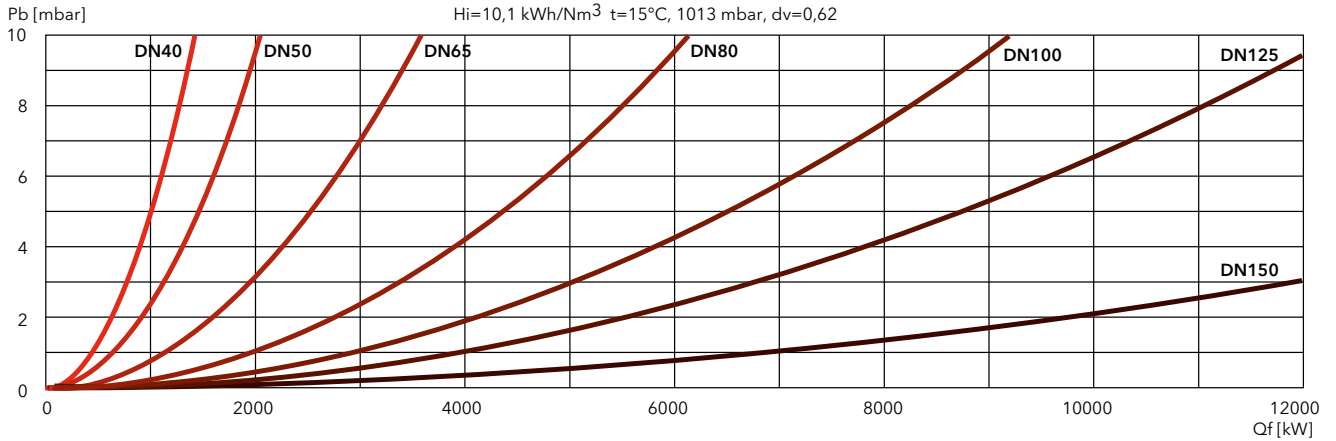

GAS VALVE AND CONNECTION PIPE

PIC. 1A

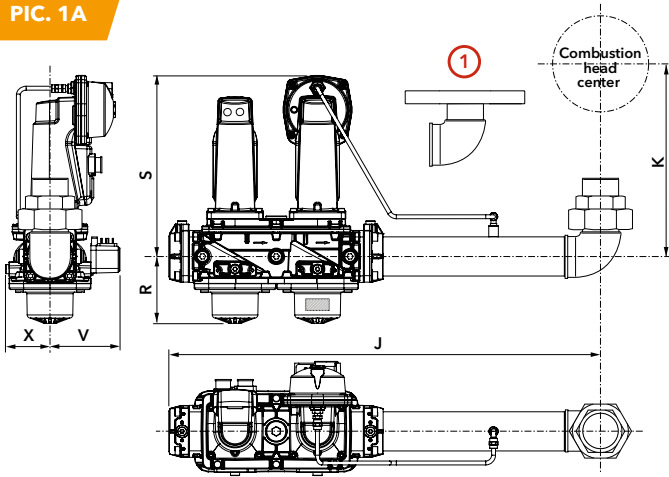

PIC. 1B

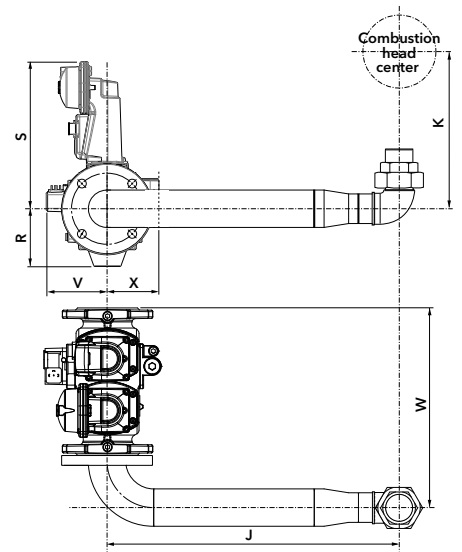

PIC. 1C

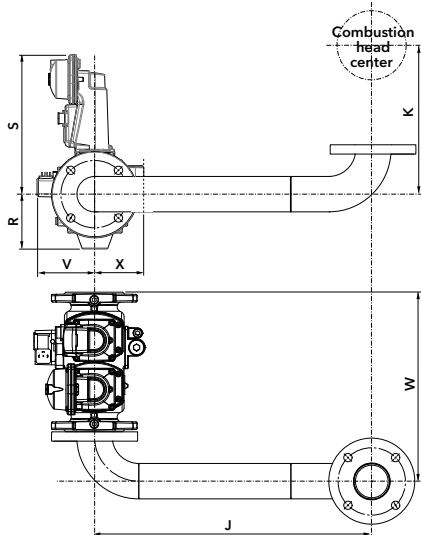

PIC. 2A

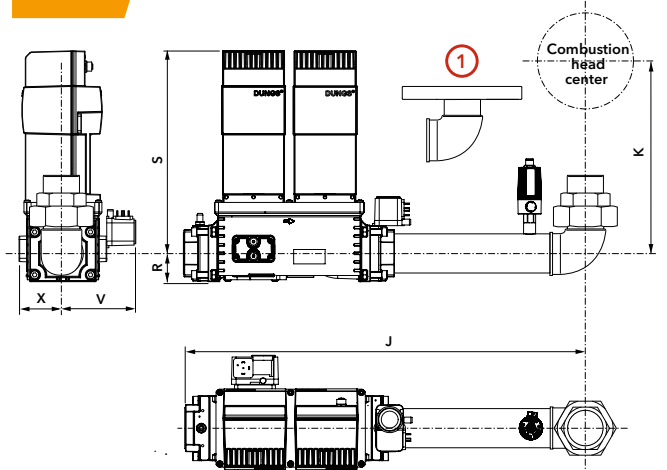

PIC. 2B

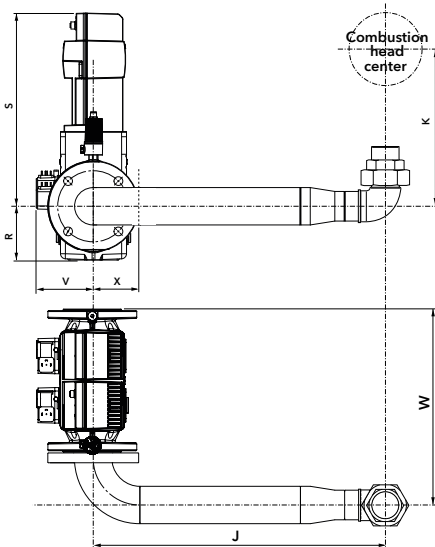

PIC. 2C

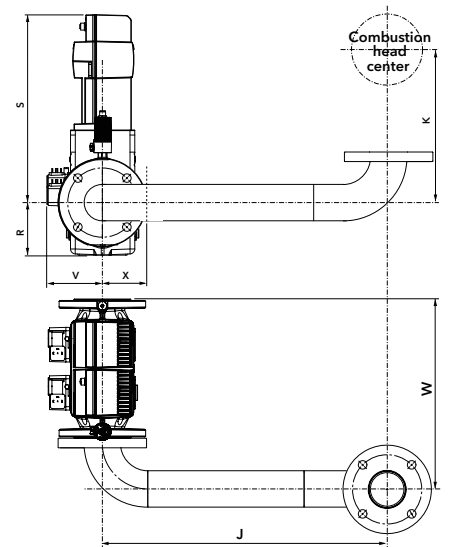

DIMENSIONS

Burner model	Gas valve model	Gas train code	Connection pipe code	Ø	Pic.	J	K	W	R	S	V	X
EK-TRON 5.300 G-E... EK-TRON 6.350 G-E...	VGD20.503	3148683	3144686	d2"	1A	650	355	-	103	279	108	68
	VGD40.065	3148684	3148771	DN65	1B	605	355	400	118	303	151	81
	VGD40.080	3148685	3148772	DN80	1B	605	355	440	132	313	148	88
	VGD40.100	3148686	3148773	DN100	1B	605	355	480	145	331	137	131
	MBE 050	3148693	3144686	d2"	2A	630	355	-	44	313	115	60
	MBE 065	3148694	3148771	DN65	2B	605	355	400	106	382	113	90
	MBE 080	3148695	3148772	DN80	2B	605	355	420	106	382	118	97
	MBE 100	3148696	3148773	DN100	2B	605	355	460	106	382	134	113
EK-TRON 6.400 G-E...	VGD20.503	3148683	3148770	s2"	1A Ⓢ	650	370	-	103	279	108	68
	VGD40.065	3148684	3145997	DN65	1C	670	370	410	118	303	151	81
	VGD40.080	3148685	3145864	DN80	1C	670	370	435	132	313	148	88
	VGD40.100	3148686	3145821	DN100	1C	670	370	480	145	331	137	131
	MBE 050	3148693	3148770	d2"	2A Ⓢ	630	355	-	44	313	115	60
	MBE 065	3148694	3145997	DN65	2C	670	370	415	106	382	113	90
	MBE 080	3148695	3145864	DN80	2C	670	370	435	106	382	118	97
	MBE 100	3148696	3145821	DN100	2C	670	370	475	106	382	134	113
EK-TRON 7.500 G-E... EK-TRON 7.600 G-E...	VGD20.503	3148683	3148770	s2"	1A Ⓢ	650	370	-	103	279	108	68
	VGD40.065	3148684	3148766	DN65	1C	780	375	420	118	303	151	81
	VGD40.080	3148685	3148767	DN80	1C	780	375	435	132	313	148	88
	VGD40.100	3148686	3148768	DN100	1C	780	375	480	145	331	137	131
	VGD40.125	3148687	3148769	DN125	1C	790	375	565	175	345	159	137
	MBE 050	3148693	3148770	d2"	2A Ⓢ	630	355	-	44	313	115	60
	MBE 065	3148694	3145997	DN65	2C	780	375	415	106	382	113	90
	MBE 100	3148696	3145821	DN100	2C	780	375	480	106	382	134	113
EK-TRON 5.300 G-R... EK-TRON 6.350 G-R...	VGD20.503	3148688	3144686	d2"	1A	650	355	-	103	279	108	68
	VGD40.065	3148689	3148771	DN65	1B	605	355	400	118	303	151	81
	VGD40.080	3148690	3148772	DN80	1B	605	355	440	132	313	148	88
	VGD40.100	3148691	3148773	DN100	1B	605	355	480	145	331	137	131
	MBE 050	3148697	3144686	d2"	2A	630	355	-	44	313	115	60
	MBE 065	3148698	3148771	DN65	2B	605	355	400	106	382	113	90
	MBE 080	3148699	3148772	DN80	2B	605	355	420	106	382	118	97
	MBE 100	3148700	3148773	DN100	2B	605	355	460	106	382	134	113
EK-TRON 6.400 G-R...	VGD20.503	3148688	3148770	s2"	1A Ⓢ	650	370	-	103	279	108	68
	VGD40.065	3148689	3145997	DN65	1C	670	370	410	118	303	151	81
	VGD40.080	3148690	3145864	DN80	1C	670	370	435	132	313	148	88
	VGD40.100	3148691	3145821	DN100	1C	670	370	480	145	331	137	131
	MBE 050	3148697	3148770	d2"	2A Ⓢ	630	355	-	44	313	115	60
	MBE 065	3148698	3145997	DN65	2C	670	370	415	106	382	113	90
	MBE 080	3148699	3145864	DN80	2C	670	370	435	106	382	118	97
	MBE 100	3148700	3145821	DN100	2C	670	370	475	106	382	134	113
EK-TRON 7.500 G-R... EK-TRON 7.600 G-R...	VGD20.503	3148688	3148770	s2"	1A Ⓢ	650	370	-	103	279	108	68
	VGD40.065	3148689	3148766	DN65	1C	780	375	420	118	303	151	81
	VGD40.080	3148690	3148767	DN80	1C	780	375	435	132	313	148	88
	VGD40.100	3148691	3148768	DN100	1C	780	375	480	145	331	137	131
	VGD40.125	3148692	3148769	DN125	1C	790	375	565	175	345	159	137
	MBE 050	3148697	3148770	d2"	2A Ⓢ	630	355	-	44	313	115	60
	MBE 065	3148698	3145997	DN65	2C	780	375	415	106	382	113	90
	MBE 100	3148700	3145821	DN100	2C	780	375	480	106	382	134	113

GAS VALVE AND CONNECTION PIPE

PIC. 1A

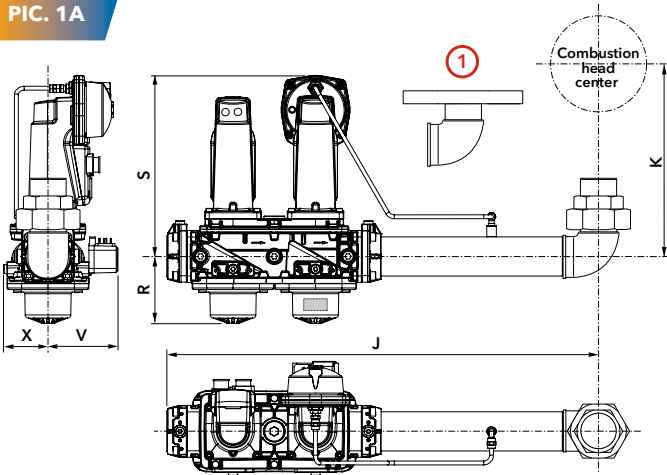

PIC. 1B

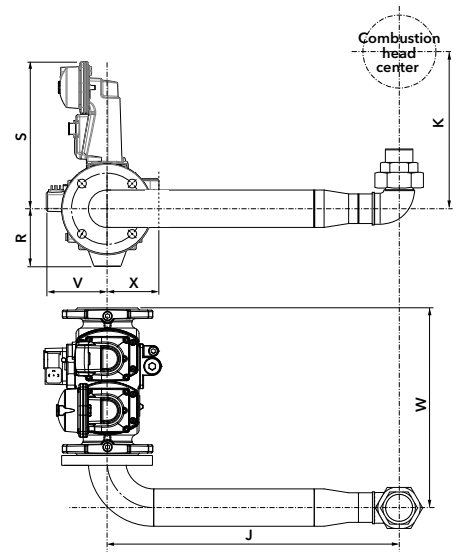

PIC. 1C

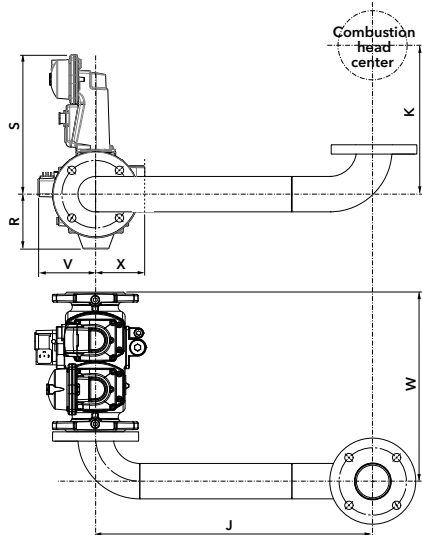

PIC. 2A

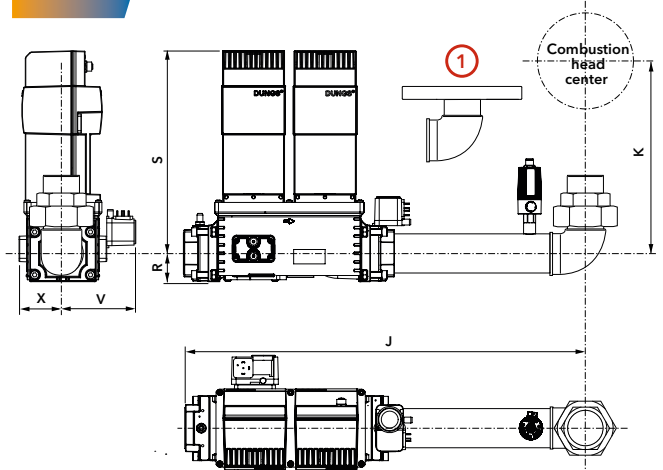

PIC. 2B

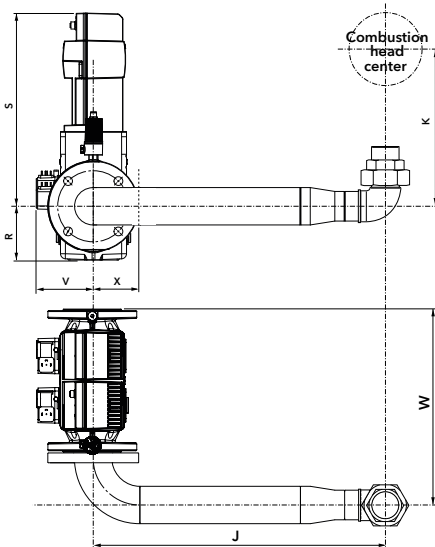

PIC. 2C

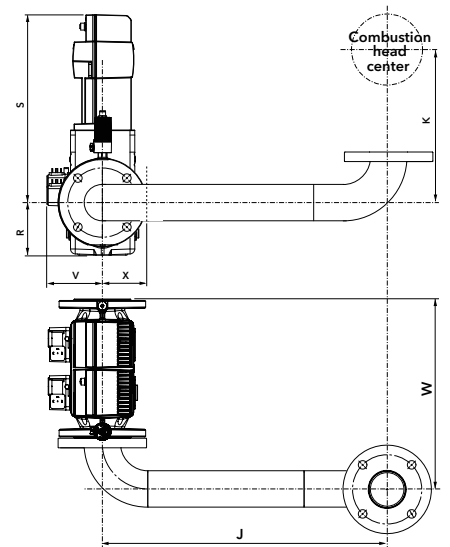

DIMENSIONS

Burner model	Gas valve model	Gas train code	Connection pipe code	Ø	Pic.	J	K	W	R	S	V	X
EK-TRON 5.170 GL-EX2	VGD20.503	3148683	3144686	d2"	1A	650	355	-	103	279	108	68
	VGD40.065	3148684	3148771	DN65	1B	605	355	400	118	303	151	81
	VGD40.080	3148685	3148772	DN80	1B	605	355	440	132	313	148	88
	MB-DLE 415	3149611	3144686	d1"1/2	2D	629	355		79	169	94	56
	MB-DLE 420	3149612	3144686	d2"	2D	629	355	-	76	220	94	56
EK-TRON 5.200 GL-EX2	VGD20.503	3148683	3144686	s2"	1A	650	355	-	103	279	108	68
	VGD40.065	3148684	3148771	DN65	1B	605	355	400	118	303	151	81
	VGD40.080	3148685	3148772	DN80	1B	605	355	440	132	313	148	88
	MB-DLE 420	3149612	3144686	d2"	2D	629	355	-	76	220	94	56
EK-TRON 6.350 GL-EX2	VGD20.503	3148683	3144686	s2"	1A	650	355	-	103	279	108	68
	VGD40.065	3148684	3148771	DN65	1B	605	355	400	118	303	151	81
	VGD40.080	3148685	3148772	DN80	1B	605	355	440	132	313	148	88
	VGD40.100	3148686	3148773	DN100	1B	605	355	480	145	331	137	131
	MBE 050	3148693	3144686	d2"	2A	630	355	-	44	313	115	60
	MBE 065	3148694	3148771	DN65	2B	605	355	400	106	382	113	90
	MBE 080	3148695	3148772	DN80	2B	605	355	420	106	382	118	97
MBE 100	3148696	3148773	DN100	2B	605	355	460	106	382	134	113	
EK-TRON 6.400 GL-EX2	VGD20.503	3148683	3148770	s2"	1A ①	650	370	-	103	279	108	68
	VGD40.065	3148684	3148766	DN65	1C	670	370	410	118	303	151	81
	VGD40.080	3148685	3148767	DN80	1C	670	370	435	132	313	148	88
	VGD40.100	3148686	3148768	DN100	1C	670	370	480	145	331	137	131
	MBE 050	3148693	3148770	d2"	2A ①	630	355	-	44	313	115	60
	MBE 065	3148694	3148766	DN65	2C	670	370	415	106	382	113	90
	MBE 080	3148695	3148767	DN80	2C	670	370	435	106	382	118	97
	MBE 100	3148696	3148768	DN100	2C	670	370	475	106	382	134	113

LCM MODULE

Module required for O ₂ control, frequency converter and communication buses connections	3147726
---	---------

COMMUNICATION MODULES

ModBus/BT3 (EBM100) to be mounted on the burner	3147727
ProfiBus/BT3 (PBM100) to be mounted on the burner	3147728

FREQUENCY CONVERTER FOR EXTERNAL INSTALLATION

IP55 with: • EMC filter • Inductor • Control panel	3 kW	3757067
	4 kW	3757068
	5,5 kW	3757069
	7,5 kW	3757070
	11 kW	3757071
	15 kW	3757072

POWER REGULATOR

Power regulator RWF55 stand-alone and kit wiring	3147730
--	---------

PROBES

Temperature probe	Pt100, temperature range: -50° ... 400°C (100 mm) + pocket tube (76 mm)	3750070
Water probe	Temperature range: 0 ... 130°C	3148819
Steam probe	Pressure range: 0 ... 2 bar	3148820
	Pressure range: 0 ... 4 bar	3148821
	Pressure range: 0 ... 10 bar	3148822
	Pressure range: 0 ... 16 bar	3148823
	Pressure range: 0 ... 25 bar	3148824
	Pressure range: 0 ... 40 bar	3148825
Hot air / liquid probe	Temperature range: 0 ... 450°C	3148826
Thermocouple	J type, temperature up to 750°C	3148827

MAX GAS PRESSURE SWITCH

Kit supplied loose Note: this kit is not required for Dungs MBE gas trains, where it is already included	3148675
---	---------

KIT LPG

Kit LPG for EK-TRON G-E and G-R	for EK-TRON 5.300	3149283
	for EK-TRON 6.350, 6.400 and 7.500	3149268
	for EK-TRON 7.600	3149269
Kit LPG for EK-TRON G-EF3 and G-RF3	for EK-TRON 5.300 and 6.350	3149097
	for EK-TRON 6.400	3149098
	for EK-TRON 7.500 and 7.600	3149099

OIL SPILL BACK NOZZLES

Fluidics W2 50° Threaded connection, 7/8"	40 kg/h	3145231
	50 kg/h	3145232
	60 kg/h	3142763
	70 kg/h	3145233
	80 kg/h	3145234
	90 kg/h	3145235
	100 kg/h	3142704
	115 kg/h	3142564
	130 kg/h	3142515
	145 kg/h	3142516
	160 kg/h	3142421
	180 kg/h	3142492
	200 kg/h	3142690
	225 kg/h	3142489
	250 kg/h	3142768
	275 kg/h	3142805
	300 kg/h	3142490
	330 kg/h	3142703
	360 kg/h	3142513
	400 kg/h	3142497
450 kg/h	3142483	
500 kg/h	3142699	
550 kg/h	3142416	
600 kg/h	3142506	

ACOUSTIC SHROUDS

<ul style="list-style-type: none"> • sound level reduction (sound pressure level): ca. 20 ... 30 dB(A) • sheet metal casing, structured coating, isolation with temperature resistant mineral wool • noise absorption material acc. DIN 4102, covered with a glass fibre layer, covered with perforated sheet metal, galvanised • easily disassembled into elements: base plate, side covers, top cover, air inlet section • all elements easily connected via quick locks • height of noise reduction casing adjustable on wheels • feed through for gas, oil and electrical connections integrated in side covers following the requirements • air inlet via noise reduction line • if required, an oil recuperation tub can be integrated on the base plate • for some boiler types a supporting frame for the casing may be necessary, due to the height of the burner tube over the floor <p>Before submitting your order please provide information on the boiler model and the type of installation</p>	Codes on request
--	------------------

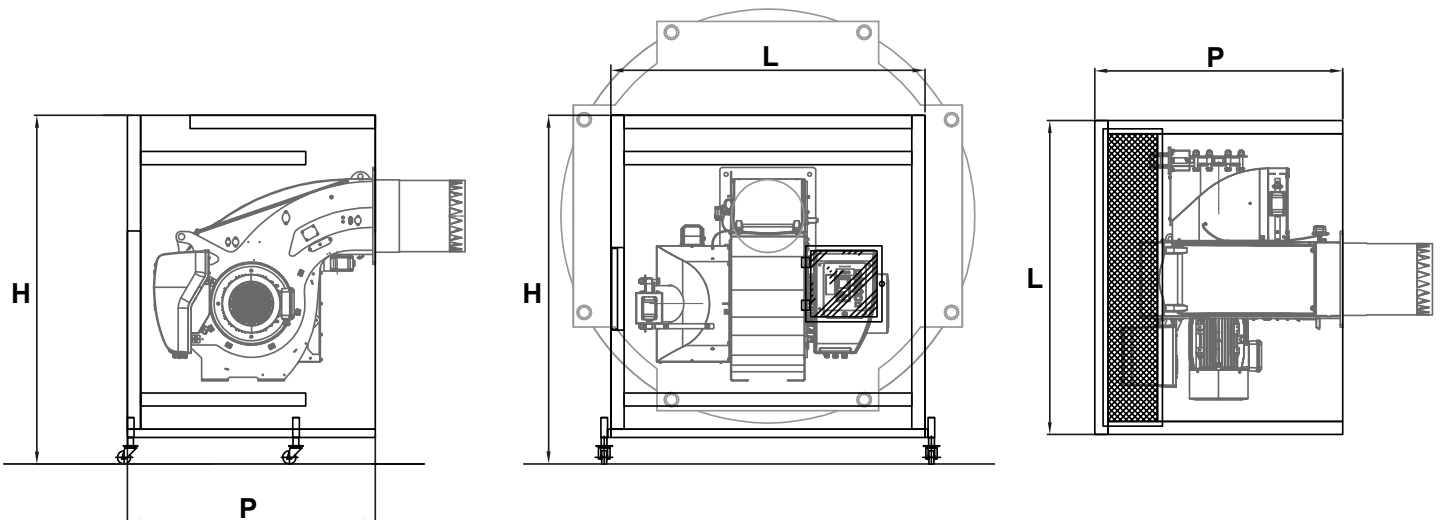

O₂ TRIM FOR BT300, ETAMATIC AND ETAMATIC OEM, FMS/VMS

This kit is used to optimize the combustion in order to keep the air excess as much stable as possible irrespective of the changes that can occur during operations, for instance slight calorific value variations, combustion air temperature and pressure. This improves the seasonal efficiency and therefore reduces the fuel consumption.

The kit includes the following components:

- Lambda transmitter LT3
- Lambda probe LS2
- Probe installation fitting (PIF)
- Gas extraction device (GED)

The control unit has to be installed close to the probe (max 10 m of cable).

The probe needs a calibration but no reference gas is necessary.

The display shows the O₂ content.

Maximum distance between the LT3 and the burner control panel is 500 m.

	Additional LSB modules installed at LT3	GED length	Code
Kit for O₂ trim (LT3 + LS2) Flue temp max 300 °C - Display for O₂ visualization (Note: for models equipped with BT3 this kit needs a LCM module installed in the burner control panel)	none	150 mm	3759296
		300 mm	3759297
		450 mm	3759298
	4x 0/4-20 mA output	150 mm	3759299
		300 mm	3759300
		450 mm	3759301
	4x 0/4-20 mA output + 4x digital output	150 mm	3759302
		300 mm	3759303
		450 mm	3759304

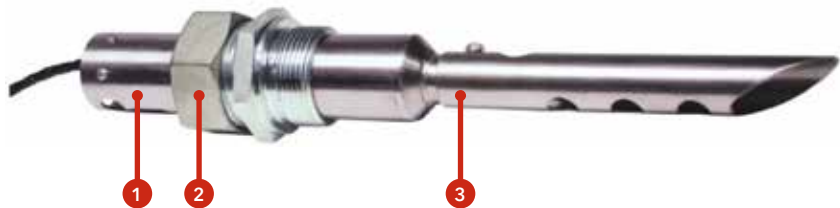

1. Lambda Probe LS2 in standard housing up to 300°C (572°F); default cable length is 2 m (6.5 ft), FEP, with connecting plug
2. Probe installation fitting (PIF)
3. Gas extraction device (GED)

The LS2 lambda probe is equipped with a 2 meter long connection cable that connects the sensor to the transmitter (LT3). It is possible to extend the connection up to a maximum distance of 10 meters (for greater lengths the conformity expires) with a ready-made cable and a probe connection box (PCB).

Description	Code	
Extension for LS2	5m ready-made cable	3759318
	PCB (probe connection box)*	3759319

The PCB is a small terminal box that is connected to the 2 meter long cable already existing on the probe. The wiring between the PCB and the transmitter must be carried out on the construction site with suitable cables and trained personnel.

*: the PCB is mandatory if the end user chooses to use his own connecting cable and not one of those proposed (max total length remains 10m)

O₂/CO_e TRIM FOR BT300, ETAMATIC AND ETAMATIC OEM, FMS/VMS

This kit is used for optimizing the combustion in order to keep the air excess as low as possible in order to maximize the seasonal efficiency and therefore minimize the fuel consumption.
 In addition to the features of the O₂ trim only, this kit reduces the air excess to its minimum because this system continuously measures the content of unburned fuel (CO_e) in the flue: should the air excess be reduced too much, the CO_e raises and the system reacts by increasing the air excess in order to keep firing in safe conditions.

The kit includes the following components:

- Lambda transmitter LT3-F
- Lambda probe KS1D
- Probe installation fitting (PIF)
- Gas extraction device (GED)

The control unit has to be installed close to the probe (max 10 m of cable).
 The probe needs a calibration but no reference gas is necessary.
 The display shows the O₂ and CO_e content.
 Maximum distance between the LT3-F and the burner control panel is 500 m.

Note: this system is not suitable for GL-EUF and L-EUF burners

	Additional LSB modules installed at LT3-F	GED length	Code
Kit for O₂ trim and CO control (LT3-F + KS1D) Flue temp max 300 °C (Note: for models equipped with BT3 this kit needs a LCM module installed in the burner control panel)	none	150 mm	3759305
		300 mm	3759306
		450 mm	3759307
	4x 0/4-20 mA output	150 mm	3759308
		300 mm	3759309
		450 mm	3759310
	4x 0/4-20 mA output + 4x digital output	150 mm	3759311
		300 mm	3759312
		450 mm	3759313

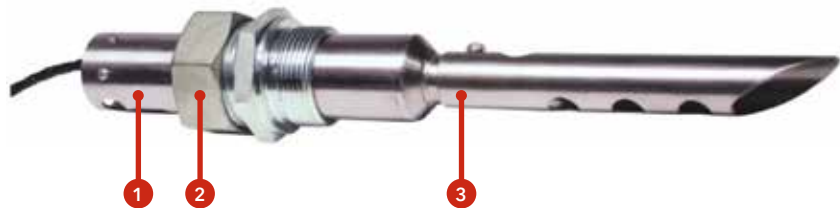

1. Lambda Probe KS1D in standard housing up to 300°C (572°F); default cable length is 2 m (6.5 ft), FEP, with connecting plug
2. Probe installation fitting (PIF)
3. Gas extraction device (GED)

The KS1D lambda probe is equipped with a 2 meter long connection cable that connects the sensor to the transmitter (LT3-F). It is possible to extend the connection up to a maximum distance of 10 meters (for greater lengths the conformity expires) with a ready-made cable and a probe connection box (PCB).

Description		Code
Extension for KS1D	5m ready-made cable	3759318
	PCB (probe connection box)*	3759319

The PCB is a small terminal box that is connected to the 2 meter long cable already existing on the probe. The wiring between the PCB and the transmitter must be carried out on the construction site with suitable cables and trained personnel.

*: the PCB is mandatory if the end user chooses to use his own connecting cable and not one of those proposed (max total length remains 10m)

Subsidiaries ELCO

GERMANY

ELCO GmbH
Dreieichstraße 10
Mörfelden-Walldorf
Tel.: +49 (0) 6105 287-287
Fax: +49 (0) 6105 287-199

NETHERLANDS

Elco Burners B.V.
Meerpaalweg, 1 - 1332 BB Almere
P.O. box 30048 - 1303 AA Almere
Tel.: +31 088 69 573 11
Fax: +31 088 69 573 90

SWITZERLAND

Elcotherm AG
Sarganserstrasse 100
7324 Vilters
Tel.: +41 (0)81 725 25 25
Fax: +41 (0)81 723 13 59

AUSTRIA

ELCO Austria GmbH
Aredstraße 16 - 18
2544 Leobersdorf
Tel.: +43 (0)2256 639 99 32
Fax: +43 (0)2256 644 11

FRANCE

14, rue du Saule Trapu
Parc d'activité du Moulin
91882 Massy
Tel.: +33 01 60 13 64 64
Fax: +33 01 60 13 64 65

ITALY

Via Roma, 64
31023 Resana (TV)
Tel.: +39 0423 719500
Fax: +39 0423 719580

UK & IRELAND

Ariston Thermo UK Ltd
Suite 3, The Crown House
Blackpole East, Blackpole Road,
Worcester WR3 8SG
Tel.: +44 01905 788010

CHINA

Ariston Heating Solutions (China) Co., Ltd.
25th floor, T1, Shanghai T-Center
No. 1428 Daduhe Road, Putuo District, Shanghai
Tel.: +86 21 6039 8691
Fax: +86 21 6039 8620

Contact us to know more
about our products and solutions

www.elco-burners.com
contact@elco-burners.com

Version 2.5 | 23/08/2024

All rights reserved | ELCO declines all responsibility for any printing mistakes or any content transcription in the present document and reserves the right to modify, without prior notice, any product datas or characteristics