

Ecoflam

TECHNICAL CATALOGUE



www.ecoflam-burners.com

INDEX OF CONTENTS

	The Company	p. 4
	Burner composition	p. 10
	Designation of burners and gas trains	p. 11
	Range overview	p. 12
	Gas Range	
	MAX GAS	p. 16
	BLU	p. 52
	Light Oil Range	
	MAX	p. 122
	MAIOR	p. 130
	Heavy Oil Range	
	MAXFLAM / OILFLAM	p. 142
	Dual Fuel Range	
	MULTICALOR	p. 156
	MULTIFLAM	p. 206
	Duoblock Range	
	TS RANGE	p. 224
	Residential Range	p. 234
	Special Versions	p. 235
	Light process applications	p. 236
	FGR System	p. 240
	Gas Trains	p. 242
	Kits and Accessories	p. 250

Ecoflam

CUSTOMIZED
SOLUTIONS
FOR ANY
TYPE OF
APPLICATION



OUR
EXPERIENCE



Thanks to more than **50 years of experience** in the design and production of burners, Ecoflam offers a full range of blown air pressure jet burners covering an extremely wide range of power, from small products for residential heating applications to high power burners dedicated to the industrial segment. Ecoflam burners are renowned worldwide for providing high efficiency products with reliable operation, significant energy savings and extreme ease of installation, maintenance and flexible boiler-burner matching.

OUR
MISSION



Following a philosophy of **continuous improving**, the R&D Laboratory is constantly working to produce better results.

The development of new advanced combustion technologies allows to offer solutions in respect of the most stringent environmental regulations and to create the perfect condition to face the new upcoming market requests, such as Ultra Low NOx burners or products suitable to work with alternative fuels.

OUR PROFESSIONAL TEAM



Handle demands of products for specific applications, designing highly configured products and providing immediate problem-solving are characteristics that set Ecoflam's talented **technicians and engineers** apart.

Additionally, Ecoflam can rely on a global network of service technicians to assist with burner installation, commissioning, and periodic maintenance, all of which are critical to ensuring end user satisfaction, Ecoflam's top priority.

OUR GROUP



Ecoflam is part of **Ariston Group Burners Division**.



One of the company's most valuable assets is the synergy amongst the various brands of the Division, which enables the sharing of technologies and expertise that drive innovation and enable continuous improvement of products and services.

OUR COMMERCIAL AND TECHNICAL NETWORK

Manufacturing is carried out in the factory of Resana (Treviso, Italy) and our products are distributed worldwide thanks to a wide and highly qualified network of partners.

In 50 years, Ecoflam has been capable to build loyal partnerships and today can count on reliable partners in **more than 100 Countries**. They distribute Ecoflam products in their Countries of competence, they have excellent knowledge on the products and can carry out commissioning and service by keeping constantly in touch with our Headquarters.

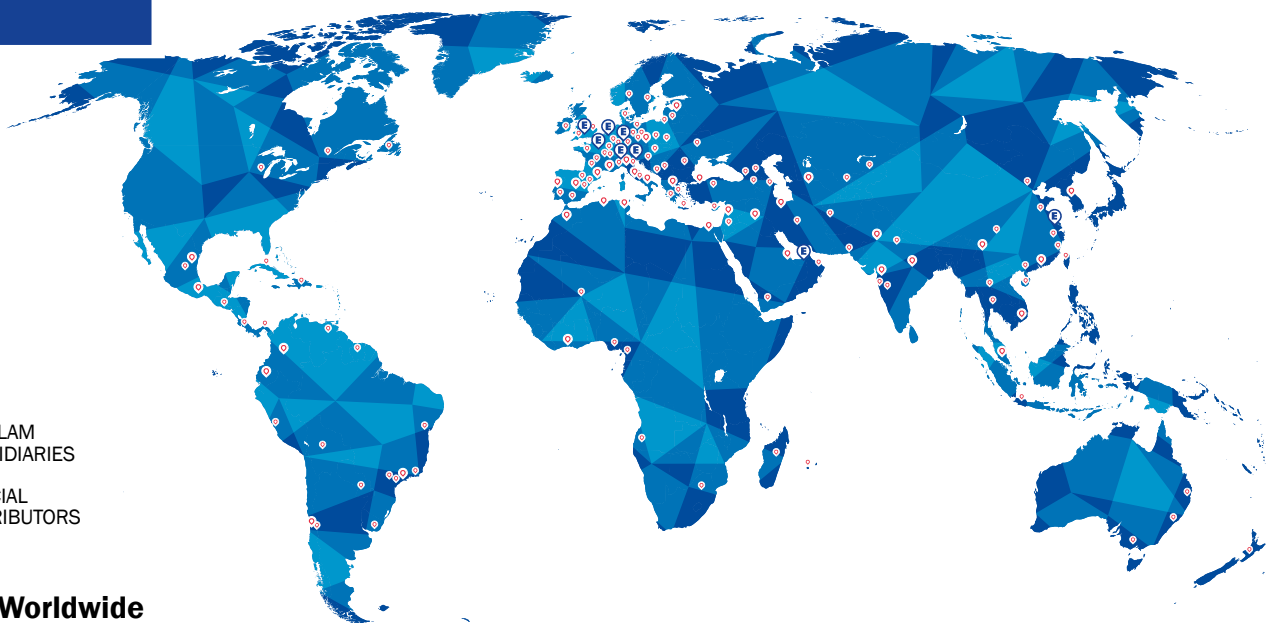

-  ECOFLAM SUBSIDIARIES
-  OFFICIAL DISTRIBUTORS

Ecoflam Worldwide

Headquarters in Italy, subsidiary in UK

Sales Representative Offices in Europe, Dubai and China

Commercial network of distributors/importers and direct customers reaching more than 100 Countries

NEW TECHNOLOGIES AND ALTERNATIVE FUELS



Throughout its history, Ecoflam has always been engaged in continuous research and development in order to improve its products.

Today, in a period in which the issue of **environmental sustainability** has acquired fundamental importance, Ecoflam is even more focused on the development of:

- Low NOx and Ultra Low NOx combustion technologies
- Burners suitable to work with alternative fuels
- Sustainable and efficient products solutions and processes

FGR

Ecoflam developed a performant range of products equipped with the external **FGR technology** (Flue Gas Recirculation): this technology enables to guarantee emissions of **less than 30 mg/kWh**, a value which is hard to obtain with conventional combustion systems.

BIO

HVO

SYN GAS

The development of burners suitable for work also with **alternative fuels** (such as biogas, biofuel, HVO, syngas, etc.), allows Ecoflam to offer highly efficient products with extremely low polluting emissions values, in order to satisfy even the most demanding regulations.

CUSTOMIZED SOLUTIONS

Ecoflam is renowned for its ability to conceive and build flexible products and to propose **customized solutions for any type of applications**.

Successful and satisfied customers, both from OEM or distribution fields, demonstrate throughout the years that Ecoflam is able to meet their requests offering a wide range of special products capable to satisfy even the most difficult ones.



Thanks to its strong expertise in customization, Ecoflam boasts many different solutions for an extremely wide range of applications. The flexibility of the Ecoflam range allows to grant quick response to each customer request, even the most demanding in term of technical specifications.



HEATING



INCINERATORS & WASTE



AGRICULTURE



ASPHALT & BUILDING



TEXTILE & DRYING



FOOD PRODUCTION



WOOD BOILERS



ENGINEERING



CHEMICAL PLANTS



PLANT MODERNIZATION

TIME TO MARKET



To promptly deal with the requests of an ever changing market, Ecoflam has adopted a finished products and spare parts **warehouse of over 8000 square meters**.

Quick response to customer requests and consistent warehouse availability allow to reduce the delivery time and give a better support to the end user.

COMMISSIONING, MAINTENANCE AND INSPECTION



The burner is a crucial part of the installation.

For a safe and efficient operation of the system it is very important that the burner is commissioned by an expert: the combustion will be optimally adjusted over the whole power range of the burner, and all the safeties will be tested.

To keep the installation in good conditions, it is also important to maintain the burner periodically and to inspect all the safeties to ensure that the system operates safely.

Ecoflam Service technicians are able, like no other, to perform these tasks perfectly, in order to ensure that the system operates without problems.

THE BURNER ACADEMY



In order to respond to the needs of the customers, Ecoflam created the **Burner Academy**, a real school where the know-how of the internal technicians is diffused to partners and customers.

It's an opportunity for boiler room personnel, operators and engineers to attend a series of training sessions carried out on test bench by highly qualified instructors.

The Burner Academy uses various training locations where boilers are installed and where people can be trained in theory and in practice.

ORIGINAL SPARE PARTS



Spare parts have always had a great importance inside the Ecoflam world. Considering the high amount of parts involved in every single product, some of these parts might naturally need to be substituted. Ecoflam can count on a international network offering original spare parts in order to guarantee the highest quality, reliability and safe continued operation of the appliance.

WORLDWIDE REFERENCES

For half a century, the expertise and skill of our team has been constantly field-tested across the countless installations put into operation, always achieving remarkable results. Through a vast worldwide distribution system, ECOFLAM continues to respond every day to the requests of its customers and to export its products and services **all over the world**.



BEIJING (CHINA)



2 monoblock gas burners:
BLU 4000.3 PRE FGR
 Total nominal output: 8 MW
 Burners equipped with FGR system
 (<30 mg/kWh)

**ULTRA
LOW
NOx**



KÖLN (GERMANY)



1 monoblock gas burner:
BLU 1500.1 PRE LN
 Nominal output: 1,6 MW
 Low NOx class 3 (≤80 mg/kWh)

**LOW
NOx**



IRAPUATO (MEXICO)



1 monoblock light oil burner:
MAIOR P 150.1
 Nominal output: 1,8 MW



CUTTACK (INDIA)



2 monoblock dual fuel (gas/light oil) burners:
MULTICALOR 800.1 PR
 Total nominal output: 17 MW



BEIJING (CHINA)



2 duoblock gas burners:
BLU TS 12000.1 LN PRE FGR
 Total nominal output: 26 MW
 Burners equipped with FGR system
 (<30 mg/kWh)

**ULTRA
LOW
NOx**



ARKLOW (IRELAND)



1 monoblock dual fuel (gas/light oil) burner:
MULTICALOR 800.1 PRE
Nominal output: 8,5 MW



BEIJING (CHINA)



3 duoblock dual fuel (gas/light oil) burners:
MULTICALOR TS 1000.1 LN PRE FGR
Total nominal output: 31,5 MW
Burners equipped with FGR system
(<30 mg/kWh in gas, <150 mg/kWh in oil)

**ULTRA
LOW
NOx**



BAKU (AZERBAIJAN)



2 monoblock dual fuel (gas/light oil) burners:
MULTICALOR 800.1 PR
Total nominal output: 17 MW



MYSORE (INDIA)



1 duoblock dual fuel (gas/heavy oil) burner:
MULTIFLAM TS 200.1 PRE
Nominal output: 2 MW



MEXICO CITY (MEXICO)



156 monoblock gas burners:
MAX GAS 40 P
Total nominal output: 7,5 MW
Low NOx class 3 (≤ 80 mg/kWh)

**LOW
NOx**



BEIJING (CHINA)



6 monoblock gas burners:
1x **BLU 2000.3 PRE FGR**
5x **BLU 6000.3 PRE FGR**
Total nominal output: 31 MW
Burners equipped with FGR system
(<30 mg/kWh)

**ULTRA
LOW
NOx**

BURNER COMPOSITION

BURNER BODY

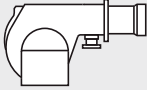
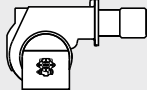
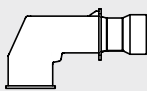
	Gas range Dual fuel range	Burner body with built-in combustion head is delivered in one single box. Gas train and additional kits and accessories are delivered separately
	Light oil range Heavy oil range	Burner body with built-in combustion head is delivered in one single box. Additional kits and accessories to be ordered and delivered separately
	Duoblock range	Burner body with built-in combustion head is delivered in one single box. Safety valve, gas train and additional kits and accessories are delivered separately

GAS TRAIN

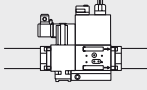
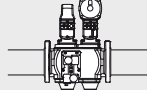
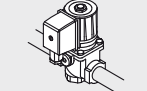
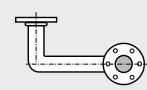
	MB- valves	MultiBloc Dungs: compact double solenoid valve with built-in filter, gas governor and gas pressure switch
	VGD- valves	VGD Siemens: double gas valve with actuators, gas governor and gas pressure switch. Filter not included, to be ordered separately
	Export configuration	Configuration depending on the models, to be selected in compliance with local safety regulations
	Gas train connection pipe	

MODULATION KIT

POWER REGULATOR	Load controller to transform progressive version burners into modulating burners
PROBES	Temperature and pressure probes

MAIN KITS AND ACCESSORIES

DIAGNOSTIC TOOL	Diagnostic tool for Ariston BCU
TIGHTNESS CONTROL	Tightness control device for gas train, available in different models depending on the type of gas train selected
MAXIMUM GAS PRESSURE SWITCH	Maximum gas pressure switch, to be installed in order to comply with local safety regulations
SILENCER	Kit to be fitted to the air inlet
LPG KIT	LPG transformation kit for gas burner
OTHER ACCESSORIES	Gas governors, gas filters, antivibration joints, ball valves, oil filters, nozzles, etc.

SPECIAL CONFIGURATIONS AND OTHER SERVICES

SPECIAL CONFIGURATIONS¹	Continuous ventilation, remote control panel, higher IP ratings, out of standard blast tube lengths, customized voltages, swirl system, etc.
AFTER-SALE SERVICE	The Ecoflam Service Department offers start-up service, after-sale maintenance and technical training courses ²
SPARE PARTS	Ecoflam original spare parts

¹: Feasibility of all out of standard configurations will be evaluated on request

²: Contact us to know more about our after-sale service

DESIGNATION

BURNER

RANGE NAME BY FUEL TYPE	
MAX GAS, BLU	Natural gas or LPG
MAX, MAIOR	Light oil
MAXFLAM, OILFLAM	Heavy oil
MULTICALOR	Dual fuel: gas/light oil
MULTIFLAM	Dual fuel: gas/heavy oil

OPERATION MODE	
-	One stage
R	One stage with pre-heater (light oil)
P	Soft-start
AB	Two stages
AB HS	Two stages with hydraulic jack
PR	Progressive/modulating mechanical
PR-AB	Progressive/modulating mechanical gas / two stages oil
PRE	Progressive/modulating electronic
MD	Modulating with PID

OUT OF STANDARD CONFIGURATIONS	
FCA	Frequency converter arrangement
HT	High temperature version
CV	Continuous ventilation
72H	72-hour continuous operation
FGR	Flue gas recirculation
SW	Blast tube with swirl
S4	4-head configuration
O	Version for OEM
S	Out of standard burner

ELECTRICAL POWER SUPPLY	
-	Standard configurations: 1 phase: 230 V - 50 Hz 3 phase: 400 V - 50 Hz
230V 50-60	230 V - 50-60 Hz
380-60	380 V - 60 Hz
460-60	460 V - 60 Hz

BLU TS 1500.1 LN PR TL HT LPG 380-60

BURNER STRUCTURE	SIZE (rough output)	EMISSIONS	HEAD LENGTH	BURNER CONTROL	FUEL TYPE
- Monoblock	Gas: in kW	- Class 1 or 2	TC Short	TW Ariston BCU	BF Biofuel
TS Duoblock	Oil or dual fuel: in kg/h	LN Class 3 (EN676/EN267)	TM Medium	- other brands	HV High viscosity oil
		E ErP compliant	TL Long		LPG LPG
					K Kerosene

GAS TRAIN

MANUFACTURER

D	Dungs
K	Kromschröder
S	Siemens
H	Honeywell
B	Brahma
U	UNI-Geraete

VALVE FEATURES

1	Valve with built-in pressure governor
2	2-stage valve with built-in pressure governor
3	Valve without built-in pressure governor

GAS PRESSURE SWITCH ARRANGEMENT

PS1	Single gas pressure switch upstream of the first shutter
PS2	Single gas pressure switch between the two shutters
PS3	Two gas pressure switches, upstream of and between the shutters

VOLTAGE

-	220 V or 230V; either 50 or 60 Hz
110	110 V (irrespective of the frequency)
120	120 V (irrespective of the frequency)

GT - S2 - VGD20503 - DN80 - PS2 - A - 110

VALVE MODEL (examples)

MBDLE412	Dungs MultiBloc MBDLE412
MBZRDLE410	Dungs MultiBloc (2 stages) MBZRDLE410
VGD20	Siemens VGD20
VGD40	Siemens VGD40

VALVE NOMINAL DIAMETER (examples)

RP15	Rp1/2", threaded connection
...	
RP50	Rp2", threaded connection
DN40	DN40, flanged connection
...	
DN150	DN150, flanged connection

OTHER DEVICES (empty if not applicable)

F	Filter included (either as a component or included in the regulator)
G	Governor
A	Anti-vibration joint
M	Manual valve
V	AGP
S	Out of standard gas train

The flexibility of the Ecoflam technologies allows the manufacturing of highly customized products suitable to work with any fuel or combination of fuels, covering a range from 17 kW to 42 MW:

GAS RANGE

MAX GAS

MONOBLOCK BURNERS
FROM 17 TO 700 kW

▶ Page 16



BLU

MONOBLOCK BURNERS
FROM 200 TO 17000 kW

▶ Page 52



LIGHT OIL RANGE

MAX

MONOBLOCK BURNERS
FROM 18 TO 735 kW

▶ Page 122



MAIOR

MONOBLOCK BURNERS
FROM 415 TO 17000 kW

▶ Page 130



HEAVY OIL RANGE

MAXFLAM

MONOBLOCK BURNERS
FROM 68 TO 570 kW

▶ Page 142



OILFLAM

MONOBLOCK BURNERS
FROM 464 TO 17000 kW

▶ Page 148



DUAL FUEL
RANGE

MULTICALOR

MONOBLOCK BURNERS
FROM 190 TO 17000 kW

► Page 156



MULTIFLAM

MONOBLOCK BURNERS
FROM 414 TO 17000 kW

► Page 206



DUOBLOCK
RANGE

TS RANGE

DUOBLOCK BURNERS
FROM 230 TO 42000 kW

► Page 224



SPECIAL
VERSIONS

OUT OF STANDARD

MONOBLOCK AND DUOBLOCK BURNERS
FROM 230 TO 42000 kW

► Page 234



RANGE OVERVIEW

Range

MAX GAS

P	1 stage	ErP compliant	MAX GAS 40 E / 70 E / 105 E / 120 E MAX GAS 170 E / 250 E MAX GAS 350 E / 400 E / 500 E	p. 18
PAB	2 stages			
PR	Progressive/modulating mechanical			
PRE	Progressive/modulating electronic	LOW NOx Class 5	MAX GAS 350 E / 400 E / 500 E	p. 30
P	1 stage	LOW NOx Class 3	MAX GAS 40 / 70 / 105 / 120 MAX GAS 170 / 250 MAX GAS 350 / 400 / 500 / 700	p. 36
PAB	2 stages			
PR	Progressive/modulating mechanical			
PRE	Progressive/modulating electronic		MAX GAS 700	p. 46

Range

BLU

PAB	2 stages	LOW NOx Class 3	BLU 700.1 LN / 1000.1 LN / 1200.1 LN BLU 1500.3 LN / 2000.3 LN / 2500.3 LN BLU 3000.3 LN / 4000.3 LN BLU 5000.3 LN / 6000.3 LN	p. 54
PR	Progressive/modulating mechanical			
PRE	Progressive/modulating electronic			
PAB	2 stages	LOW NOx Class 2	BLU 1000.1 / 1200.1 BLU 1700.1 / 2000.1 BLU 1700.2 / 2500.2 BLU 3000.1 / 4000.1 BLU 5000.1 / 6000.1	p. 82
PR	Progressive/modulating mechanical			
PRE	Progressive/modulating electronic			
			BLU 7000.1 / 8000.1 / 10000.1 / 12000.1 BLU 15000.1 / 18000.1	p. 94
			BLU 1000.1 / 1200.1 BLU 1700.1 / 2000.1 BLU 1700.2 / 2500.2 BLU 3000.1 / 4000.1 BLU 5000.1 / 6000.1	p. 102
			BLU 7000.1 / 8000.1 / 10000.1 / 12000.1 BLU 15000.1 / 18000.1	p. 114

Range

MAX

-	1 stage		MAX 1 / 4 / 8 / 12 MAX 15 / 20 / 25 / 30 MAX 35 / 45 / 70	p. 124
P AB	2 stages			
P AB HS	2 stages with hydraulic system			

Range

MAIOR

P AB	2 stages		MAIOR P 45 / P 60 / P 80 / P 120 MAIOR P 150.1 / P 200.1 MAIOR P 300.1 / P 400.1 MAIOR P 500.1 / P 600.1	p. 132
P AB HS	2 stages with hydraulic system			
P PR	Progressive/modulating mechanical			
P PR	Progressive/modulating mechanical		MAIOR P 700.1 / P 800.1 / P 1000.1 / P 1200.1 MAIOR P 1500.1 / P 1800.1	p. 138

RANGE OVERVIEW

Range

MAXFLAM

-	1 stage	MAXFLAM 10	p. 144
AB	2 stages	MAXFLAM 20 MAXFLAM 30 MAXFLAM 50	

Range

OILFLAM

AB	2 stages	OILFLAM 80.1 / 120.1	p. 148
PR	Progressive/modulating mechanical	OILFLAM 170.1 / 200.1 OILFLAM 300.1 / 400.1 OILFLAM 500.1 / 600.1	
PR	Progressive/modulating mechanical	OILFLAM 700.1 / 800.1 / 1000.1 / 1200.1 OILFLAM 1500.1 / 1800.1	p. 152

Range

MULTICALOR

-	2 stages in gas and in oil Progressive/modulating mechanical - 2 stages Progressive/modulating mechanical in gas and in oil	LOW NOx Class 2	MULTICALOR 45 / 70 / 100 / 140 MULTICALOR 500.1 / 600.1	p. 158
PR-AB PR		LOW NOx Class 3	MULTICALOR 170.3 LN / 200.3 LN MULTICALOR 350.3 LN / 400.3 LN	
		LOW NOx Class 2	MULTICALOR 700.1 / 800.1 / 1000.1 / 1200.1 MULTICALOR 1500.1 / 1800.1	p. 174
	Progressive/modulating electronic	LOW NOx Class 2	MULTICALOR 70 / 100 / 140 MULTICALOR 500.1 / 600.1	p. 182
PRE		LOW NOx Class 3	MULTICALOR 170.3 LN / 200.3 LN MULTICALOR 350.3 LN / 400.3 LN	
		LOW NOx Class 2	MULTICALOR 7000.1 / 8000.1 / 10000.1 / 12000.1 MULTICALOR 15000.1 / 18000.1	p. 196

Range

MULTIFLAM

AB	2 stages	MULTIFLAM 200.1	p. 208
PR	Progressive/modulating mechanical	MULTIFLAM 300.1 / 400.1 MULTIFLAM 500.1 / 600.1	
		MULTIFLAM 700.1 / 800.1 / 1000.1 / 1200.1 MULTIFLAM 1500.1 / 1800.1	p. 216

Range

TS

PR PRE	Progressive/modulating mechanical Progressive/modulating electronic	TS 500.1 / TS 1000.1 / TS 1500.1 / TS 2000.1 TS 3000.1 / TS 4000.1 TS 6000.1 / TS 8000.1 TS 10000.1 / TS 12000.1 / TS 14000.1 TS 18000.1 / TS 20000.1 TS 23000.1 / TS 34000.1 TS 42000.1	p. 228
-----------	--	--	--------

RANGE OVERVIEW

Low NOx Class 5, ErP compliant (NOx ≤ 56 mg/kWh)

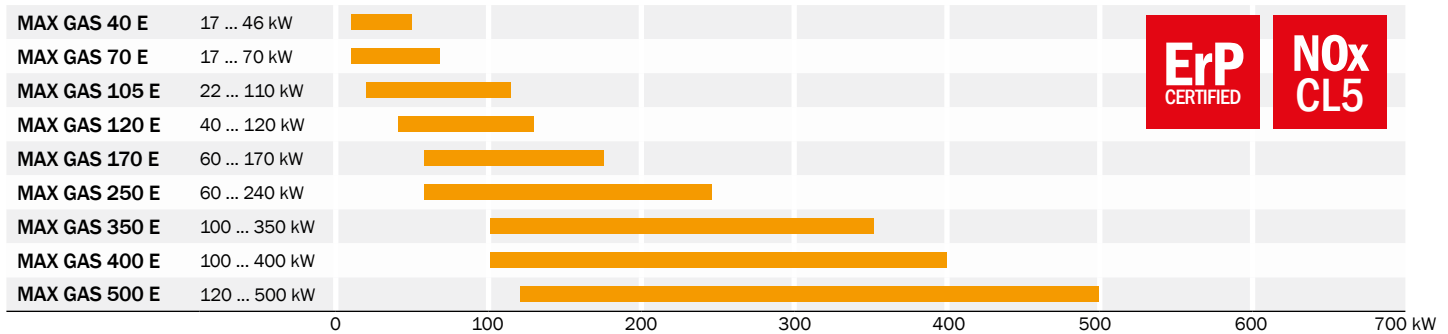

Low NOx Class 3 (NOx ≤ 80 mg/kWh)

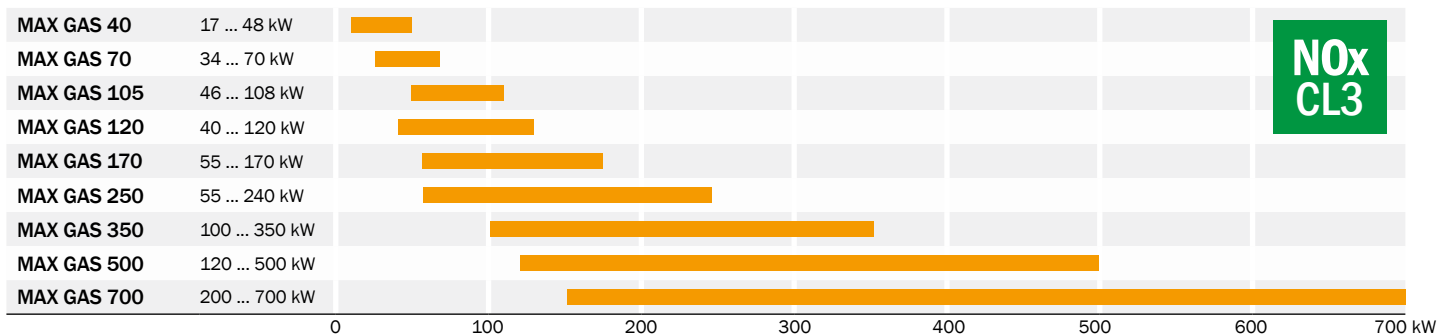

CONFIGURATIONS

MAX GAS range is available in the following operation modes:

	MAX GAS 40 ... 700 One stage Low NOx class 5, ErP compliant (up to MAX GAS 500) and Low NOx Class 3
	MAX GAS 70 ... 700 Two stages Low NOx class 5, ErP compliant (up to MAX GAS 500) and Low NOx Class 3
	MAX GAS 70 ... 700 Two stage progressive/modulating mechanical Low NOx class 5, ErP compliant (up to MAX GAS 500) and Low NOx Class 3
	MAX GAS 350 ... 700 Two stage progressive/modulating electronic Low NOx class 5, ErP compliant (up to MAX GAS 500) and Low NOx Class 3

Other available configurations:

- Progressive versions are available starting from MAX GAS 350 and can be transformed into modulating with an optional kit
- LPG versions
- Continuous ventilation versions
- High temperature versions
- OEM and other special versions on request according to feasibility

MAIN FEATURES

- All models are available in Low NOx class 3 configuration according to the EN676 Directive; models up to MAX GAS 500 are also available with ErP certified versions and are Low NOx class 5
- Different burner controllers available for each burner; two-stage models are also available with or without digital informative display
- All models are available to work with 50 and 60 Hz electrical frequency
- High efficiency fan ventilation system (HPV) allowing easy burner-boiler matching even with high combustion chamber pressure
- The hinge flange allows easy access to the combustion head without losing the original settings (starting from MAX GAS 350)

FUEL

- Natural gas (G20, G25 according to EN676)
- LPG

EMISSIONS

Class	NOx mg/kWh
3	80
5	56

All models are in compliance with EN 676 European Standard

All "E" models are in compliance with **ErP Directive** (NOx ≤ 56 mg/kWh, based on GCV)

DIRECTIVES

All products are in accordance with the following directives:

- 2014/35/EU Low Voltage Directive
- 2014/30/EU EMC Directive
- 2016/426/EU Gas Appliance Regulation
- 2006/42/EC Machine Directive
- 2011/65/EU RoHS2 Directive

MAX GAS
40 P

One stage
Low NOx
17 - 48 kW



MAX GAS
105 P

One stage
Low NOx
48 - 108 kW



MAX GAS
250 PAB

Two stages
Low NOx
55 - 240 kW



MAX GAS
500 E PRE

Two stage progressive mechanical
Low NOx
120 - 500 kW



- MAX GAS "E" burners are monoblock force-draught burners working with natural gas or LPG and covering an output range from 17 to 500 kW
- All models are equipped with low NOx combustion technology in compliance with the ErP Directive (Low NOx class 5 ≤ 56 mg/kWh)
- These models are available in three different types of operation:
 - P: one stage operation
 - PAB: two stage operation (starting from MAX GAS 120)
 - PR: two stage progressive mechanical or modulating with the installation of a power regulator and dedicated probes (starting from MAX GAS 350)
- Two different burner controllers are available for each size of burner (PAB models are also available with or without digital informative display)
- All models are available to work with 50 and 60 Hz electrical frequency
- As all the Ecoflam burners they are equipped with an adjustable combustion head for easy regulation and matching with different combustion chambers
- High efficiency fan ventilation system (HPV) allowing easy burner-boiler matching even with high combustion chamber pressure
- Multiple gas train matching are available according to the inlet gas pressure



WORKING DIAGRAMS

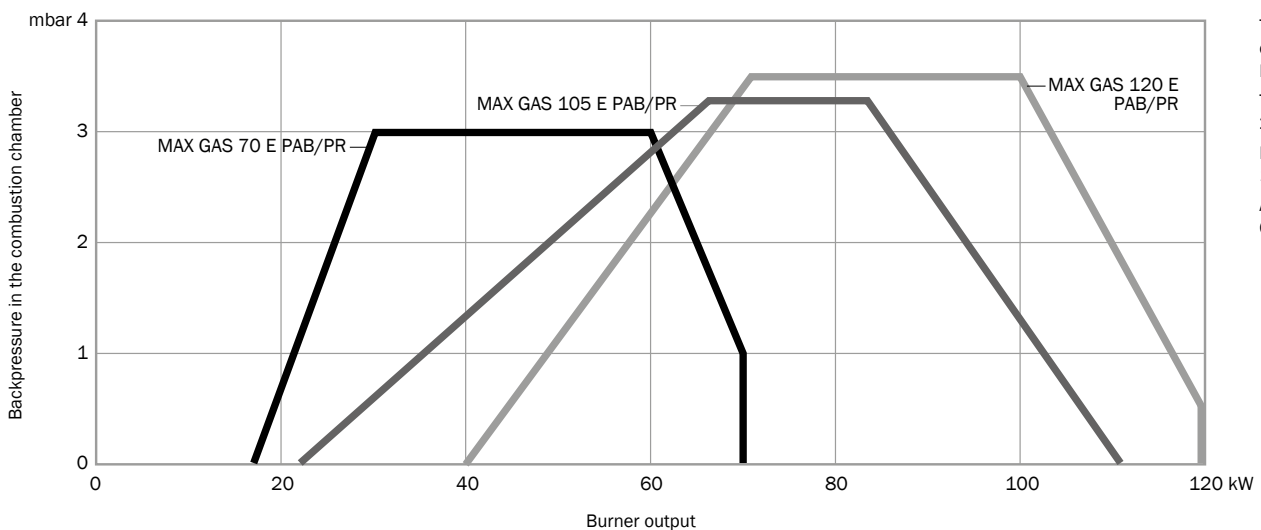
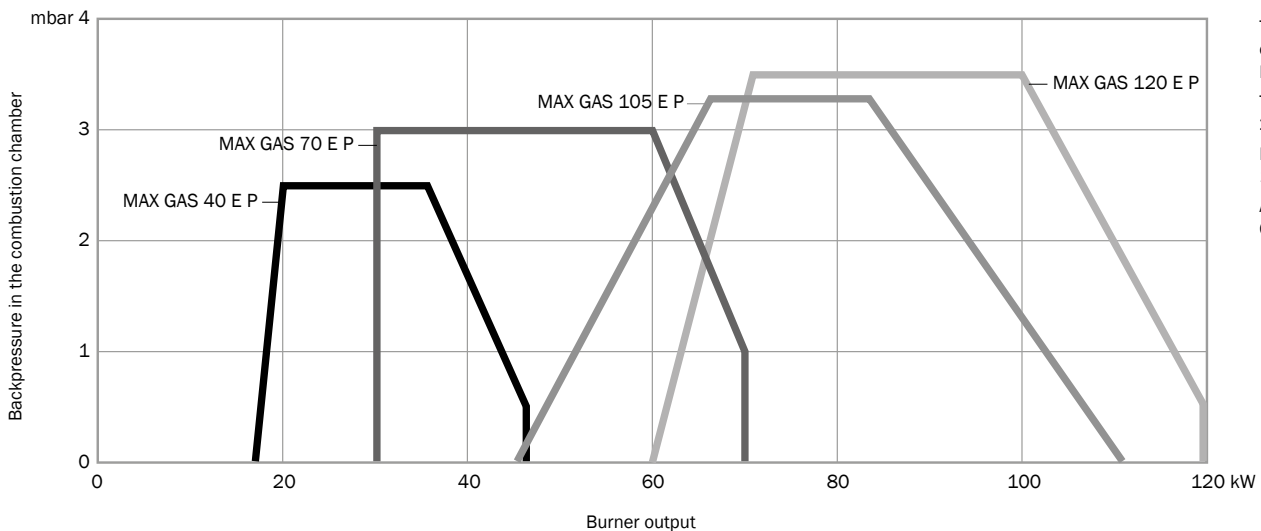

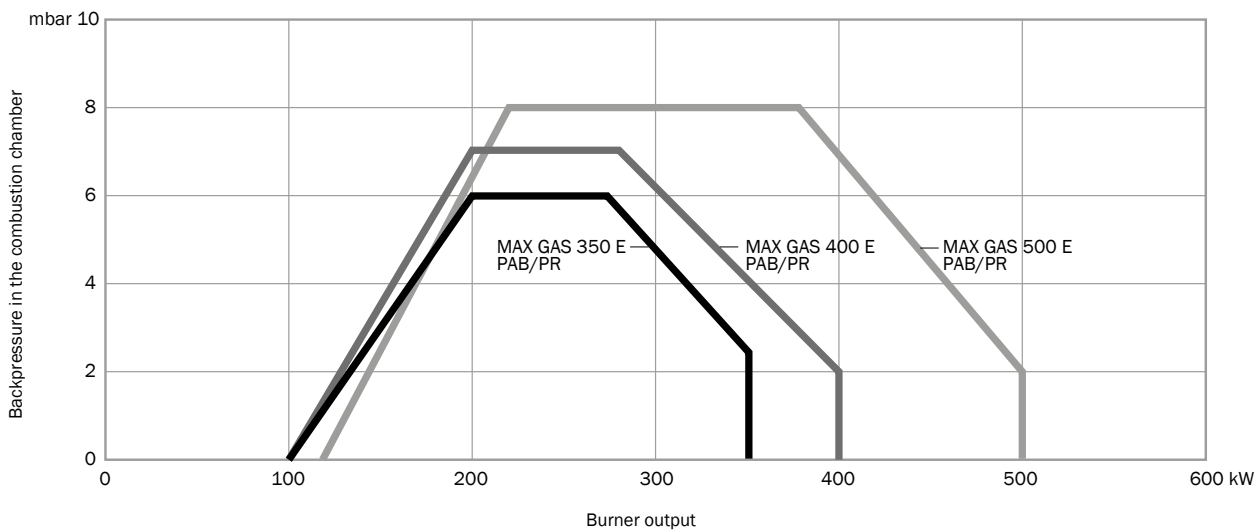
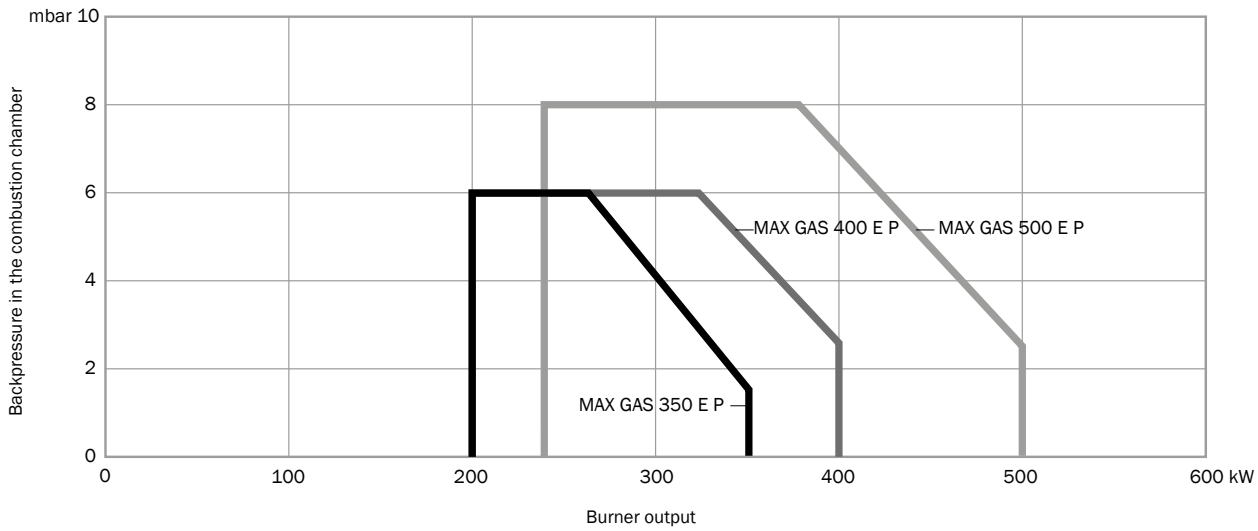
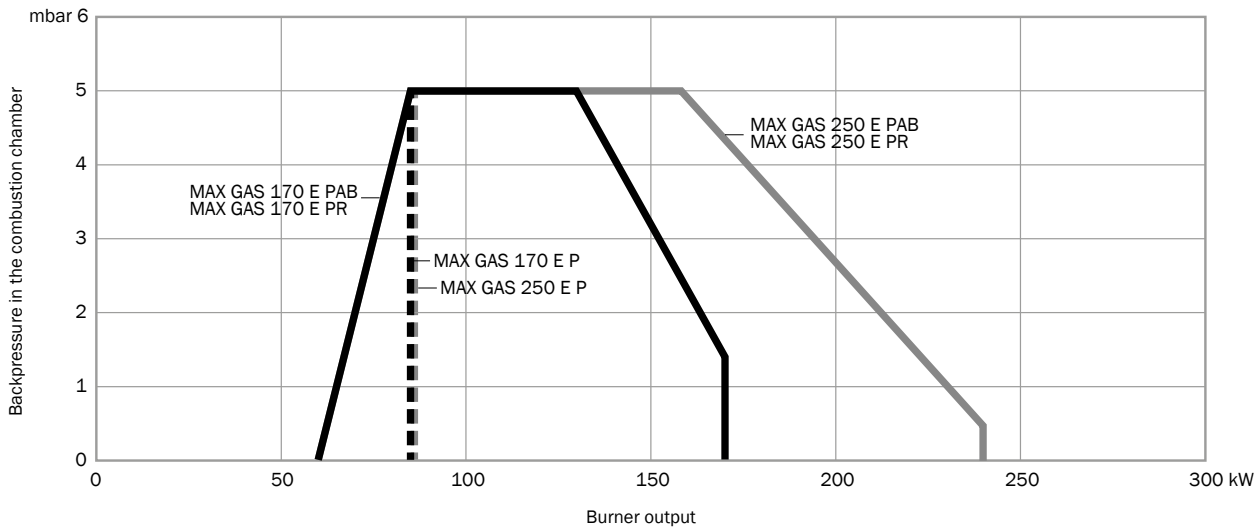

TECHNICAL DATA

Model	Operation	Output (kW)	Control box	Flame detector	Power supply	Motor (W)	Emissions
MAX GAS 40 E	P	17 - 46	TEG111 / LME11	Ionization	1/230V/50-60Hz	75	Class 5
MAX GAS 70 E	P	30 - 70	TEG111 / LME11	Ionization	1/230V/50-60Hz	75	Class 5
	PAB PR	17 - 70	LME11				
MAX GAS 105 E	P	45 - 110	TEG111 / LME11	Ionization	1/230V/50-60Hz	75	Class 5
	PAB PR	22 - 110	LME11				
MAX GAS 120 E	P	60 - 120	TEG111 / LME11	Ionization	1/230V/50-60Hz	75	Class 5
	PAB PR	40 - 120	LME11				
MAX GAS 170 E	P	85 - 170	TEG111 / LME21	Ionization	1/230V/50Hz	200	Class 5
	PAB PR	60 - 170	TCG2 / LME22 LME22				
MAX GAS 250 E	P	85 - 240	TEG111 / LME21	Ionization	1/230V/50Hz	200	Class 5
	PAB	60 - 240	TCG2 / LME22				
	PR	60 - 240	LME22				
MAX GAS 350 E	P	200 - 350	TEG111 / LME21	Ionization	1/230V/50Hz	300	Class 5
	PAB PR	100 - 350	TCG2 / LME22 LME22				
MAX GAS 400 E	P	200 - 400	TEG111 / LME21	Ionization	3/230-400V/50Hz	370	Class 5
	PAB	100 - 400	TCG2 / LME22				
	PR	100 - 400	LME22				
MAX GAS 500 E	P	232 - 500	TEG111 / LME21	Ionization	3/230-400V/50Hz	550	Class 5
	PAB	120 - 500	TCG2 / LME22				
	PR	120 - 500	LME22				

EMISSIONS

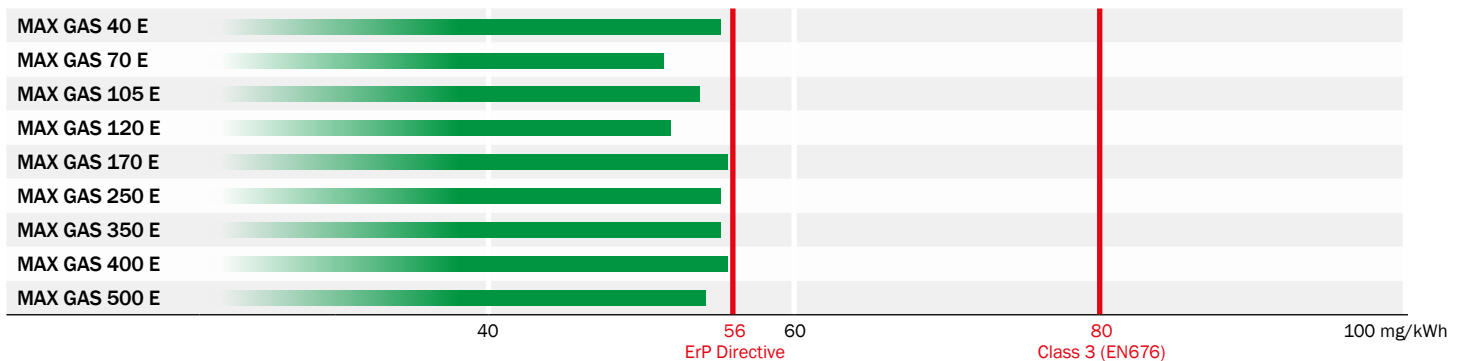

CODES

■ P - One stage, ErP compliant

Model	Ariston BCU		Siemens BCU	
	TC	TL	TC	TL
MAX GAS 40 E P	3146233	3146234	3146235	3146236
MAX GAS 70 E P	3146237	3146238	3146239	3146240
MAX GAS 105 E P	3146241	3146242	3146243	3146244
MAX GAS 120 E P	3146245	3146246	3146247	3146248
MAX GAS 170 E P	3146249	3146250	3146251	3146252
MAX GAS 250 E P	3146253	3146254	3146255	3146256
MAX GAS 350 E P	3146257	3146258	3146259	3146260
MAX GAS 400 E P	3146261	3146262	3146263	3146264
MAX GAS 500 E P	3146265	3146266	3146267	3146268

■ PAB - Two stage progressive/modulating mechanical, ErP compliant

Model	Ariston BCU		Siemens BCU	
	TC	TL	TC	TL
MAX GAS 70 E PAB	-	-	3146275	3146276
MAX GAS 105 E PAB	-	-	3146279	3146280
MAX GAS 120 E PAB	-	-	3146284	3146285
MAX GAS 170 E PAB	3146286	3146287	3146288	3146289
MAX GAS 250 E PAB	3146290	3146291	3146292	3146293
MAX GAS 350 E PAB	3146294	3146295	3146296	3146297
MAX GAS 400 E PAB	3146298	3146299	3146300	3146301
MAX GAS 500 E PAB	3146302	3146303	3146304	3146305

■ PR - Two stage progressive/modulating mechanical, ErP compliant

Model	Ariston BCU		Siemens BCU	
	TC	TL	TC	TL
MAX GAS 70 E PR	-	-	3146312	3146313
MAX GAS 105 E PR	-	-	3146316	3146317
MAX GAS 120 E PR	-	-	3146320	3146321
MAX GAS 170 E PR	-	-	3146324	3146325
MAX GAS 250 E PR	-	-	3146328	3146329
MAX GAS 350 E PR	-	-	3146332	3146333
MAX GAS 400 E PR	-	-	3146336	3146337
MAX GAS 500 E PR	-	-	3146340	3146341

OTHER AVAILABLE CONFIGURATIONS

- High temperature (HT)
- Continuous ventilation (CV)
- 60 Hz
- Post-purge
- OEM and other special versions on request according to feasibility

 All non-standard configurations are available on request: contact us to know more

PACKAGING

The complete burner with gas train and filter is delivered in a carton box containing boiler fixing accessories and a bag with technical documentation.

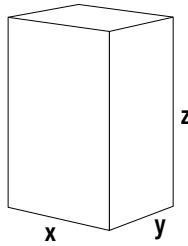

Model	x	y	z	kg
MAX GAS 40	380	400	270	8,5
MAX GAS 70	380	490	270	9
MAX GAS 105	380	490	270	9,5
MAX GAS 120	385	490	270	9,5
MAX GAS 170	380	680	510	16
MAX GAS 250	380	680	510	16
MAX GAS 350	500	1020	600	25
MAX GAS 400	500	1020	600	26
MAX GAS 500	500	1020	600	29

Dimensions in mm.

Values referred to burners in standard version; the dimensions of the package may vary according to the configuration chosen

OVERALL DIMENSIONS

i Dimensions in mm
Head length: TC short / TL long

■ MAX GAS 40 E

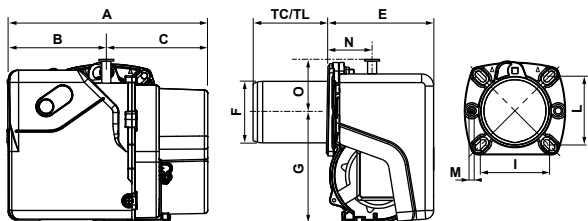

■ MAX GAS 70/105/120 E

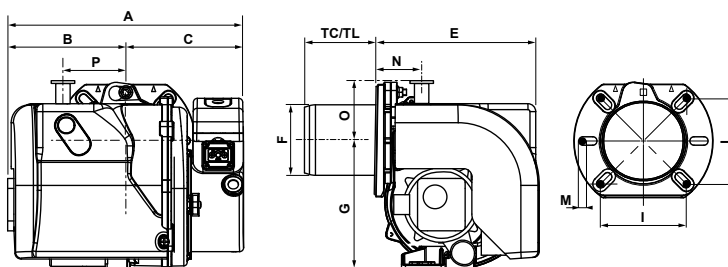

Model	A	B	C	TC	TL	E	F	G	I	L	M	N	O	P
MAX GAS 40 E P	288	143	145	85	185	153	89	160	92/107	92/107	M8	54	73	-
MAX GAS 70 E P	303	155	148	85	185	204	89	160	100/120	100/120	M8	52	71	82
MAX GAS 105 E P	317	169	148	140	220	204	89	160	100/120	100/120	M8	52	71	82
MAX GAS 120 E P	317	169	148	160	240	204	98	160	100/120	100/120	M8	52	71	82
MAX GAS 70 E PAB/PR	303	155	148	85	185	282	89	160	100/120	100/120	M8	52	71	82
MAX GAS 105 E PAB/PR	317	169	148	140	220	282	89	160	100/120	100/120	M8	52	71	82
MAX GAS 120 E PAB/PR	317	169	148	160	240	282	98	160	100/120	100/120	M8	52	71	82

■ MAX GAS 170/250 E P

■ MAX GAS 170/250 E PAB/PR

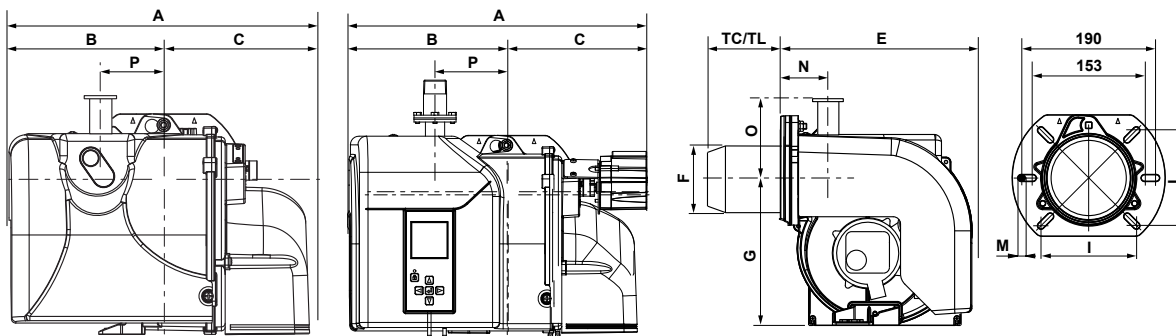

Model	A	B	C	TC	TL	E	F	G	I	L	M	N	O	P
MAX GAS 170/250 E P	392	202	190	180	280	280	125	201	106/130	106/130	M8	73	110	104
MAX GAS 170/250 E PAB	452	202	250	180	280	280	125	201	106/130	106/130	M8	73	110	104
MAX GAS 170/250 E PAB TW	435	231	204	180	280	301	125	201	106/130	106/130	M8	73	110	104
MAX GAS 170/250 E PR	452	202	250	180	280	280	125	201	106/130	106/130	M8	73	110	104

■ MAX GAS 350...500 E

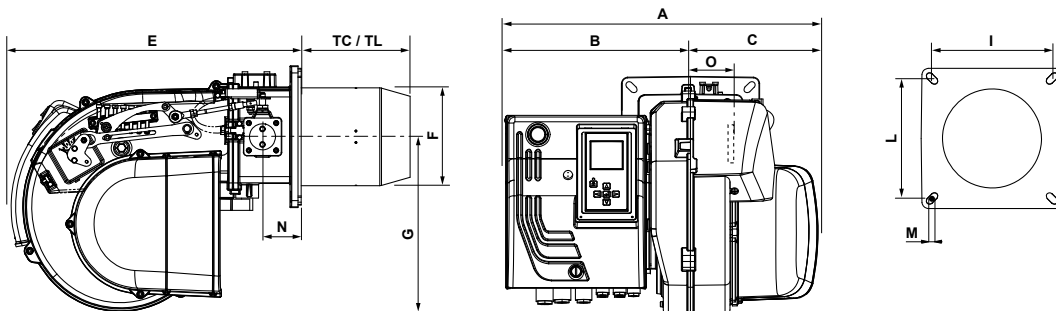

Model	A	B	C	TC	TL	E	F	G	I	L	M	N	O
MAX GAS 350...500 E P	485	277	208	175	335	466	157	280	185/200	185/200	M8	62	101
MAX GAS 350...500 E PAB TW	510	302	208	175	335	510	157	280	185/200	185/200	M8	62	101
MAX GAS 350...500 E PAB	485	277	208	175	335	466	157	280	185/200	185/200	M8	62	101
MAX GAS 350...500 E PR	510	302	208	175	335	510	157	280	185/200	185/200	M8	62	101

GAS TRAINS

■ Natural gas (G20, G25):

Model	Pressure (mbar)		Model	Size	Code	Adapter kit ¹
	min	max				
for MAX GAS 40 E P	13	65	MBC 65 DLE	1/2"	3141885	-
	16	200	MB-DLE 403	1/2"	3123944	
for MAX GAS 70 E P	15	360	MB-DLE 405	3/4"	3123560	-
	15	360	MBC 120 DLE	3/4"	3141886	
	22	65	MBC 65 DLE	1/2"	3141885	
	29	200	MB-DLE 403	1/2"	3123944	
for MAX GAS 105 E P	17	360	MB-DLE 407	3/4"	3147988	-
	24	360	MB-DLE 405	3/4"	3123560	
	23	360	MBC 120 DLE	3/4"	3141886	
	38	65	MBC 65 DLE	1/2"	3141885	
	50	200	MB-DLE 403	1/2"	3123944	
for MAX GAS 120 E P	15	360	MB-DLE 410	1"	3147989	-
	19	360	MB-DLE 407	3/4"	3147988	
	26	360	MB-DLE 405	3/4"	3123560	
	26	360	MBC 120 DLE	3/4"	3141886	
	46	65	MBC 65 DLE	1/2"	3141885	
	60	200	MB-DLE 403	1/2"	3123944	
for MAX GAS 170 E P	13	360	MB-DLE 410	1"	3123947	-
	17	360	MB-DLE 407	3/4"	3123525	
	26	360	MB-DLE 405	3/4"	3123560	
for MAX GAS 250 E P	15	360	MB-DLE 412	1"1/4	3141899	-
	17	360	MB-DLE 410	1"	3123947	
	26	360	MB-DLE 407	3/4"	3123525	
	40	360	MB-DLE 405	3/4"	3123560	
for MAX GAS 70 E PAB	16	360	MB-ZRDLE 405	3/4"	3123960	-
for MAX GAS 105 E PAB	16	360	MB-ZRDLE 405	3/4"	3123960	-
for MAX GAS 120 E PAB	16	360	MB-ZRDLE 405	3/4"	3123960	-
for MAX GAS 170 E PAB	13	360	MB-ZRDLE 410	1"	3123962	-
	17	360	MB-ZRDLE 407	3/4"	3123961	
	26	360	MB-ZRDLE 405	3/4"	3123960	
for MAX GAS 250 E PAB	15	360	MB-ZRDLE 412	1"1/4	3141901	-
	17	360	MB-ZRDLE 410	1"	3123962	
	26	360	MB-ZRDLE 407	3/4"	3123961	
	40	360	MB-ZRDLE 405	3/4"	3123960	
for MAX GAS 70 E PR	20	360	MB-VEF 407	3/4"	included ²	-
for MAX GAS 105 E PR	20	360	MB-VEF 407	3/4"	included ²	-
for MAX GAS 120 E PR	20	360	MB-VEF 407	3/4"	included ²	-
for MAX GAS 170 E PR	20	360	MB-VEF 407	3/4"	included ²	-
for MAX GAS 250 E PR	20	360	MB-VEF 412	1"1/4	included ²	-
for MAX GAS 350 E P/PAB/PR	17	360	MB-DLE 415 350/500	1"1/2	3142296	-
	20	360	MB-DLE 412 350/500	1"1/4	3142295	
	37	360	MB-DLE 410 350/500	1"	3142665	
	60	360	MB-DLE 407 350/500	3/4"	3142392	
for MAX GAS 400 E P/PAB/PR	20	360	MB-DLE 415 350/500	1"1/2	3142296	-
	35	360	MB-DLE 412 350/500	1"1/4	3142295	
	55	360	MB-DLE 410 350/500	1"	3142665	
	90	360	MB-DLE 407 350/500	3/4"	3142392	
for MAX GAS 500 E P/PAB/PR	20	360	MB-DLE 415 350/500	1"1/2	3142296	-
	35	360	MB-DLE 412 350/500	1"1/4	3142295	
	55	360	MB-DLE 410 350/500	1"	3142665	
	90	360	MB-DLE 407 350/500	3/4"	3142392	

! ¹: to be included in case of order

²: gas train included in the burner code
Gas governor and filter are included

GAS TRAINS

■ LPG (G31):

Model	Pressure (mbar)		Model	Size	Code	Kit LPG ¹	Adapter kit ¹
	min	max					
for MAX GAS 40 E P	14	65	MBC 65 DLE	1/2"	3141885	3122301	-
for MAX GAS 70 E P	18	65	MBC 65 DLE	1/2"	3141885	3122301	-
for MAX GAS 105 E P	25	65	MBC 65 DLE	1/2"	3141885	3122301	-
for MAX GAS 120 E P	27	65	MBC 65 DLE	1/2"	3141885	3122301	-
for MAX GAS 170 E P	23	360	MB-DLE 405	3/4"	3123560	3122302	3122300
for MAX GAS 250 E P	34	360	MB-DLE 405	3/4"	3123560	3122302	3122300
for MAX GAS 350 E P	33	360	MB-DLE 407 350/500	3/4"	3142392	3142431	-
for MAX GAS 400 E P	33	360	MB-DLE 407 350/500	3/4"	3142392	3142431	-
for MAX GAS 500 E P	52	360	MB-DLE 407 350/500	3/4"	3142392	3142431	-
for MAX GAS 120 E PAB	15	360	MB-ZRDLE 405	3/4"	3123960	3122301	-
for MAX GAS 170 E PAB	23	360	MB-ZRDLE 405	3/4"	3123960	3122302	3122300
for MAX GAS 250 E PAB	34	360	MB-ZRDLE 405	3/4"	3123960	3122302	3122300
for MAX GAS 350 E PAB	33	360	MB-DLE 407 350/500	3/4"	3142392	3142431	-
for MAX GAS 400 E PAB	33	360	MB-DLE 407 350/500	3/4"	3142392	3142431	-
for MAX GAS 500 E PAB	52	360	MB-DLE 407 350/500	3/4"	3142392	3142431	-

! ¹: to be included in case of order
Gas governor and filter are included

GAS TRAINS - DIMENSIONS

■ MAX GAS 40 ... 250

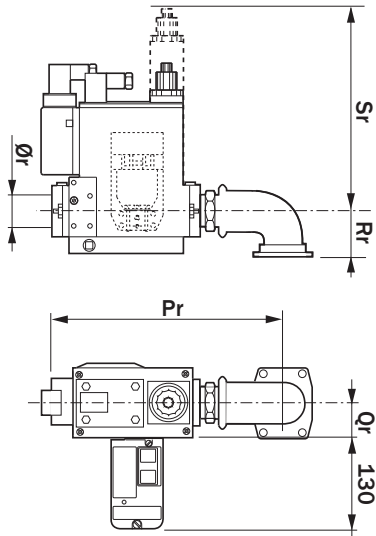

■ MAX GAS 350 ... 500

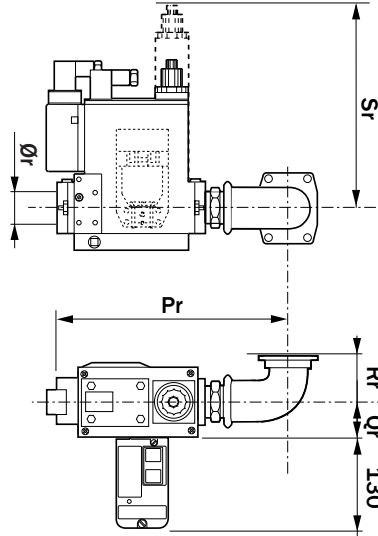

Code	Description	Ø	Dimensions (mm)				
			Pr	Qr	Rr	Sr	Ør
3123525	GT-D1-MBDLE407-RP20-MAXGAS170-250	3/4"	194	55	55	140	3/4"
3123560	GT-D1-MBDLE405-RP20-MAXGAS40-120	3/4"	194	55	35	140	3/4"
3123944	GT-D1-MBDLE403-RP15-MAXGAS40-120	1/2"	150	29	35	144	1/2"
3123947	GT-D1-MBDLE410-RP25-MAXGAS170-250	1"	218	62	55	160	1"
3123960	GT-D2-MBZRDLE405-RP20-MAXGAS40-120	3/4"	194	50	35	210	3/4"
3123961	GT-D2-MBZRDLE407-RP20-MAXGAS170-250	3/4"	194	62	55	210	3/4"
3123962	GT-D2-MBZRDLE410-RP25-MAXGAS170-250	1"	223	62	55	260	1"
3141885	GT-D1-MBC65DLE-RP15-MAXGAS40-120	1/2"	250	42	35	140	1/2"
3141886	GT-D1-MBC120DLE-RP15-MAXGAS40-120	1/2"	260	42	35	140	1/2"
3141899	GT-D1-MBDLE412-RP32-MAXGAS170-250	1"1/4	218	62	55	160	1"1/4
3141901	GT-D2-MBZRDLE412-RP32-MAXGAS170-250	1"1/4	223	62	55	260	1"1/4
3142295	GT-D1-MBDLE412-RP32-MAXGAS350-500	1"1/4	335	62	150	160	1"1/4
3142296	GT-D1-MBDLE415-RP40-MAXGAS350-500	1"1/2	400	50	150	175	1"1/2
3142392	GT-D1-MBDLE407-RP20-MAXGAS350-500	3/4"	335	55	150	140	3/4"
3142665	GT-D1-MBDLE410-RP25-MAXGAS350-500	1"	335	62	150	160	1"
3147988	GT-D1-MBDLE407-RP20-PS1-40/120	3/4"	208	43	35	140	3/4"
3147989	GT-D1-MBDLE410-RP25-PS1-40/120	1"	235	58	35	160	1"

GAS TRAINS - TOTAL DIMENSIONS CALCULATION

■ MAX GAS 40 ... 250

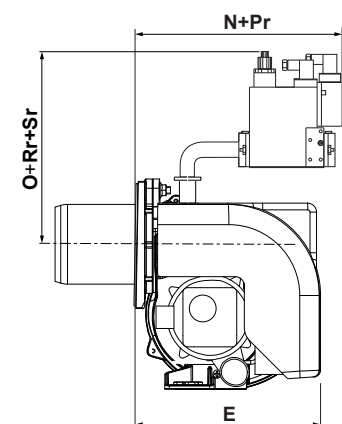

■ MAX GAS 350 ... 500

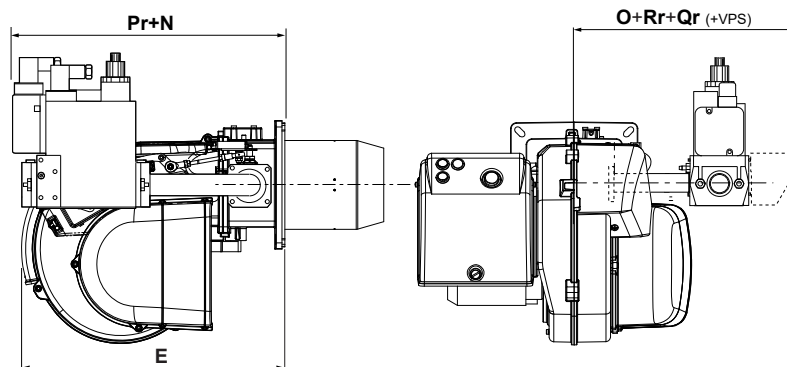

To calculate the overall dimensions, consider the greater value between E and N+Pr

■ ADAPTER KIT

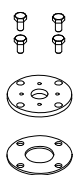

Code	Models
3122300	MAX GAS 170-250

OPTIONS

MODULATING PID CONTROLLER



Description	Code
Kit RWF50 for MAX GAS 70...250 E PR	3146829
Kit RWF50 for MAX GAS 350...500 E PR	3143713
Kit RWF55 ¹	3143714

! ¹: not applicable to MAX GAS with Ariston BCU and to MAX GAS 40...250 with Siemens BCU

i Kit supplied loose; on-board assembly available upon request
See page 257 for more information on RWF kit features

TEMPERATURE AND PRESSURE PROBES



Description	Code
Water probe, temperature range from 0 to 130 °C	3122316
Steam probe 0 ... 2 bar	3124100
Steam probe 0 ... 4 bar	3122317
Steam probe 0 ... 10 bar	3122318
Steam probe 0 ... 16 bar	3122319
Steam probe 0 ... 25 bar	3834314
Steam probe 0 ... 40 bar	3122320
Probe for external temperature from -35° to 50 °C	3122315
Hot air or liquid probe, temperature range from -50° to 400 °C	3122314
Thermocouple J type, temperature up to 750 °C (for RWF55 only)	3146725

DIAGNOSTIC TOOL FOR ARISTON BURNER CONTROL

Description	Code
TEG111 Diagnostic tool for one stage burners	3142931
PC interface 3.0	3148650

KIT LPG

Description	Models	Code
LPG conversion kit for gas burners	MAX GAS 40 ... 120	3122301
	MAX GAS 170 - 250	3122302
	MAX GAS 350 ... 500	3142431

TIGHTNESS CONTROL



Description	Code
Kit VPS504 for MB-DLE/MB-ZRDLE valves, working with natural gas ²	3122303
Kit VPS504 for MB-DLE/MB-ZRDLE valves, working with LPG ²	3142190
Kit LDU	3142314
Adapter for MAX GAS 70 ... 250 PAB	3142239
Adapter for VPS pilot gas train	3142754

! ²: for MAX GAS 70...250 PAB this kit can only be mounted with the addition of an adapter - see code 3142239

MAXIMUM GAS PRESSURE SWITCH

Description	Output range	Setting range	Code
Kit GPS 50	<6 MW	5 ... 50 mbar	3141921

OPTIONS

GAS GOVERNOR WITH BUILT-IN FILTER

! Default spring is neutral for outlet pressure range 10 - 30 mbar

Size	Maximum gas pressure	Code
Rp1/2"	500 mbar	3142519
Rp3/4"	500 mbar	3142520
Rp1"	500 mbar	3142521
Rp1"1/4	500 mbar	3142522
Rp1"1/2	500 mbar	3142523

SPRINGS FOR GAS GOVERNOR



Description	Size	Gas pressure range	Code
Green spring	1/2", 3/4", 1"	5 ... 15 mbar	3142547
Neutral spring		10 ... 30 mbar	3142548
Violet spring		25 ... 80 mbar	3142549
Brown spring		70 ... 160 mbar	3142550
Blue spring		150 ... 280 mbar	3142551
White spring		270 ... 350 mbar	3142552
Green spring	1"1/4, 1"1/2	5 ... 15 mbar	3142553
Neutral spring		10 ... 30 mbar	3142554
Violet spring		20 ... 70 mbar	3142555
Brown spring		65 ... 130 mbar	3142556
White spring		120 ... 250 mbar	3142557
Black spring		240 ... 350 mbar	3142558

ANTIVIBRATION JOINT



Size	Code
Rp1/2"	3122321
Rp3/4"	3122322
Rp1"	3122323
Rp1"1/4	3122324
Rp1"1/2	3122325

MANUAL VALVE



Size	Code
Rp1/2"	3158027
Rp3/4"	3142254
Rp1"	3121430
Rp1"1/4	3142253
Rp1"1/2	3142101

MANOMETER + PUSH BUTTON



Description	Pressure range	Code
Gas manometer 1/2"	0...60 mbar	3142056
Gas manometer 1/4"	0...250 mbar	3142055
Gas manometer 1/4"	0...1000 mbar	3142054
Push button 1/2"		3142057
Push button 1/4"		3142058

- MAX GAS "E" burners are monoblock force-draught burners working with natural gas or LPG
- All models are equipped with low NOx combustion technology in compliance with the ErP Directive (Low NOx class 5 \leq 56 mg/kWh)
- Burners are fully electronically controlled for smooth operation and simple and effective programming operation
- Tightness control is integrated for all electronic models
- All models are available to work with 50 and 60 Hz electrical frequency
- As all the Ecoflam burners they are equipped with an adjustable combustion head for easy regulation and matching with different combustion chambers
- High efficiency fan ventilation system (HPV) allowing easy burner-boiler matching even with high combustion chamber pressure
- Multiple gas train matching are available according to the inlet gas pressure
- In these models the regulating gas valve is not fitted in the burner body, but it is part of the gas train



WORKING DIAGRAMS

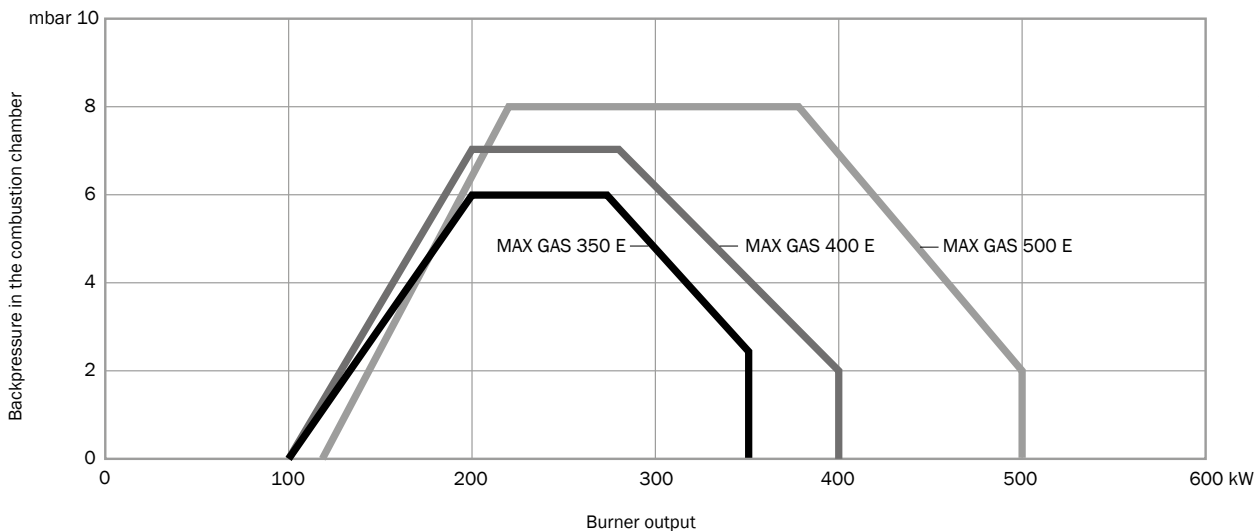

TECHNICAL DATA

Model	Operation	Output (kW)	Control box	Flame detection	Power supply	Motor (W)	Emissions
MAX GAS 350 E	PRE	100 - 350	BT320	Ionization	1/230V/50Hz	300	Class 5
MAX GAS 400 E	PRE	100 - 400	BT320	Ionization	3/230-400V/50Hz	370	Class 5
MAX GAS 500 E	PRE	120 - 500	BT320	Ionization	3/230-400V/50Hz	550	Class 5

EMISSIONS

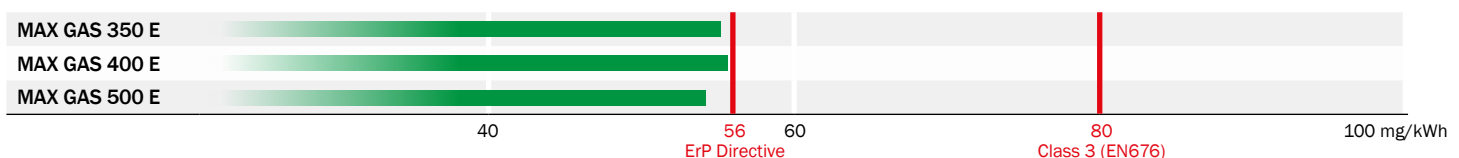

CODES

■ PRE - Two stage progressive/modulating electronic, ErP compliant

Model	TC	TL
MAX GAS 350 E PRE	3146347	3146348
MAX GAS 400 E PRE	3146349	3146350
MAX GAS 500 E PRE	3146351	3146352

OTHER AVAILABLE CONFIGURATIONS

- High temperature (HT)
- Continuous ventilation (CV)
- Post-purge
- OEM and other special versions on request according to feasibility

i All non-standard configurations are available on request: contact us to know more

PACKAGING

The complete burner with gas train and filter is delivered in a carton box containing boiler fixing accessories and a bag with technical documentation.

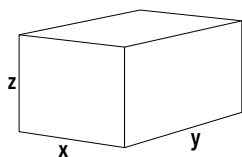

Model	x	y	z	kg
MAX GAS 350	500	1020	600	25
MAX GAS 400	500	1020	600	26
MAX GAS 500	500	1020	600	29

Dimensions in mm.
Values referred to burners in standard version; the dimensions of the package may vary according to the configuration chosen

OVERALL DIMENSIONS

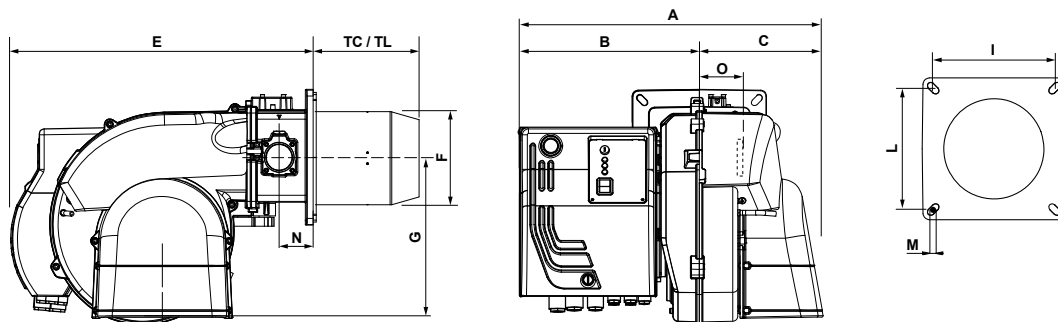

i Dimensions in mm
Head length: TC short / TL long

Model	A	B	C	TC	TL	E	F	G	I	L	M	N	O
MAX GAS 350 E PRE	510	302	208	175	335	510	157	280	185/200	185/200	M8	62	101
MAX GAS 400 E PRE	510	302	208	175	335	466	157	280	185/200	185/200	M8	62	101
MAX GAS 500 E PRE	510	302	208	175	335	510	157	280	185/200	185/200	M8	62	101

GAS TRAINS

■ Natural gas (G20, G25):

Model	Pressure (mbar)		Model	Size	Code
	min	max			
for MAX GAS 350 E PRE	17	360	MB-DLE 415 350/500	1"1/2	3149312
	20	360	MB-DLE 412 350/500	1"1/4	3149311
	37	360	MB-DLE 410 350/500	1"	3149310
	60	360	MB-DLE 407 350/500	3/4"	3149309
for MAX GAS 400 E PRE	20	360	MB-DLE 415 350/500	1"1/2	3149312
	35	360	MB-DLE 412 350/500	1"1/4	3149311
	55	360	MB-DLE 410 350/500	1"	3149310
	90	360	MB-DLE 407 350/500	3/4"	3149309
for MAX GAS 500 E PRE	20	360	MB-DLE 415 350/500	1"1/2	3149312
	35	360	MB-DLE 412 350/500	1"1/4	3149311
	55	360	MB-DLE 410 350/500	1"	3149310
	90	360	MB-DLE 407 350/500	3/4"	3149309



Gas governor and filter are included

GAS TRAINS - DIMENSIONS

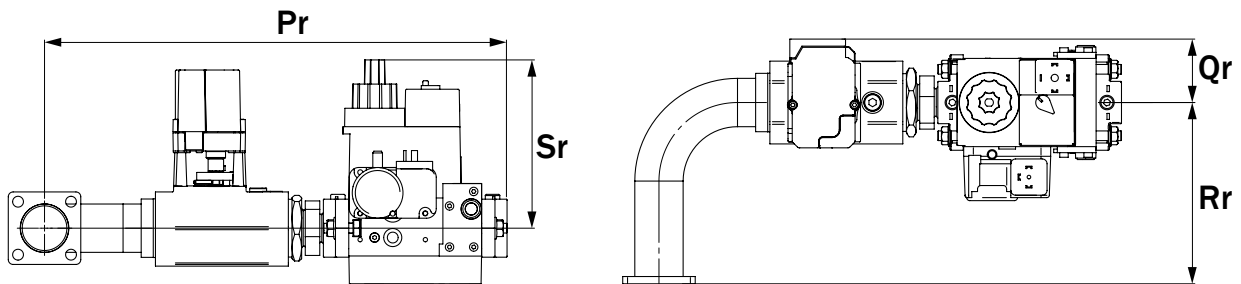

Code	Description	Ø	Dimensions (mm)			
			Pr	Rr	Qr	Sr
3149309	GT-D1-MBDLE407-RP20-PS2-D200	3/4"	385	150	58	140
3149310	GT-D1-MBDLE410-RP25-PS2-D200	1"	425	150	58	125
3149311	GT-D1-MBDLE412-RP32-PS2-D200	1"1/4	425	150	58	125
3149312	GT-D1-MBDLE415-RP40-PS2-D200	1"1/2	495	150	58	170
3149313	GT-D1-MBDLE420-RP50-PS2-D200	2"	525	150	58	220

GAS TRAINS - TOTAL DIMENSIONS CALCULATION

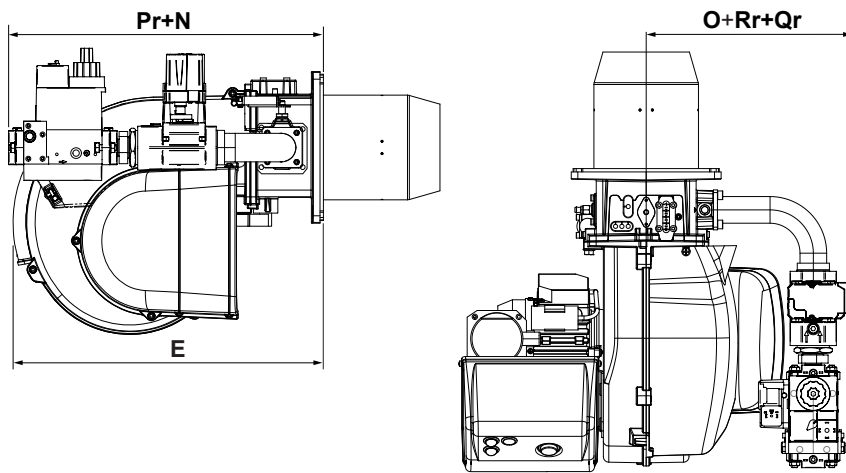

i To calculate the overall dimensions, consider the greater value between E and $N+Pr$

OPTIONS

MODULATING PID CONTROLLER



Description	Code
Kit RWF50	31437786
Kit RWF55	31437787

i Kit supplied loose; on-board assembly available upon request
See page 257 for more information on RWF kit features

TEMPERATURE AND PRESSURE PROBES



Description	Code
Water probe, temperature range from 0 to 130 °C	3122316
Steam probe 0 ... 2 bar	3124100
Steam probe 0 ... 4 bar	3122317
Steam probe 0 ... 10 bar	3122318
Steam probe 0 ... 16 bar	3122319
Steam probe 0 ... 25 bar	3834314
Steam probe 0 ... 40 bar	3122320
Probe for external temperature from -35° to 50 °C	3122315
Hot air or liquid probe, temperature range from -50° to 400 °C	3122314
Thermocouple J type, temperature up to 750 °C (for RWF55 only)	3146725

KIT LPG

Description	Models	Code
LPG conversion kit for gas burners	MAX GAS 350 ... 500	3142431

MAXIMUM GAS PRESSURE SWITCH

Description	Output range	Setting range	Code
Kit GPS 150	<15 MW	5 ... 150 mbar	3147771

OPTIONS

GAS GOVERNOR WITH BUILT-IN FILTER

! Default spring is neutral for outlet pressure range 10 - 30 mbar

Size	Maximum gas pressure	Code
Rp1/2"	500 mbar	3142519
Rp3/4"	500 mbar	3142520
Rp1"	500 mbar	3142521
Rp1"1/4	500 mbar	3142522
Rp1"1/2	500 mbar	3142523

SPRINGS FOR GAS GOVERNOR



Description	Size	Gas pressure range	Code
Green spring	1/2", 3/4", 1"	5 ... 15 mbar	3142547
Neutral spring		10 ... 30 mbar	3142548
Violet spring		25 ... 80 mbar	3142549
Brown spring		70 ... 160 mbar	3142550
Blue spring		150 ... 280 mbar	3142551
White spring	1"1/4, 1"1/2	270 ... 350 mbar	3142552
Green spring		5 ... 15 mbar	3142553
Neutral spring		10 ... 30 mbar	3142554
Violet spring		20 ... 70 mbar	3142555
Brown spring		65 ... 130 mbar	3142556
White spring	1"1/4, 1"1/2	120 ... 250 mbar	3142557
Black spring		240 ... 350 mbar	3142558

ANTIVIBRATION JOINT



Size	Code
Rp1/2"	3122321
Rp3/4"	3122322
Rp1"	3122323
Rp1"1/4	3122324
Rp1"1/2	3122325

MANUAL VALVE



Size	Code
Rp1/2"	3158027
Rp3/4"	3142254
Rp1"	3121430
Rp1"1/4	3142253
Rp1"1/2	3142101

MANOMETER + PUSH BUTTON



Description	Pressure range	Code
Gas manometer 1/2"	0...60 mbar	3142056
Gas manometer 1/4"	0...250 mbar	3142055
Gas manometer 1/4"	0...1000 mbar	3142054
Push button 1/2"		3142057
Push button 1/4"		3142058

- MAX GAS burners are monoblock force-draught burners working with natural gas or LPG and covering an output range from 17 to 700 kW
- All models are equipped with low NOx class 3 ($\text{NO}_x \leq 80 \text{ mg/kWh}$) combustion technology in compliance with EN676 European Standard; versions compliant with ErP Directive available at page 18
- These models are available in three different types of operation:
 - P: one stage operation
 - PAB: two stage operation (starting from MAX GAS 120)
 - PR: two stage progressive mechanical or modulating with the installation of a power regulator and dedicated probes (from MAX GAS 350)
- Two different burner controllers available for each size of burner (PAB models are also available with or without digital informative display)
- All models are available to work with 50 and 60 Hz electrical frequency
- As all the Ecoflam burners they are equipped with an adjustable combustion head for easy regulation and matching with different combustion chambers
- High efficiency fan ventilation system (HPV) allowing easy burner-boiler matching even with high combustion chamber pressure
- Multiple gas train matching are available according to the inlet gas pressure



WORKING DIAGRAMS

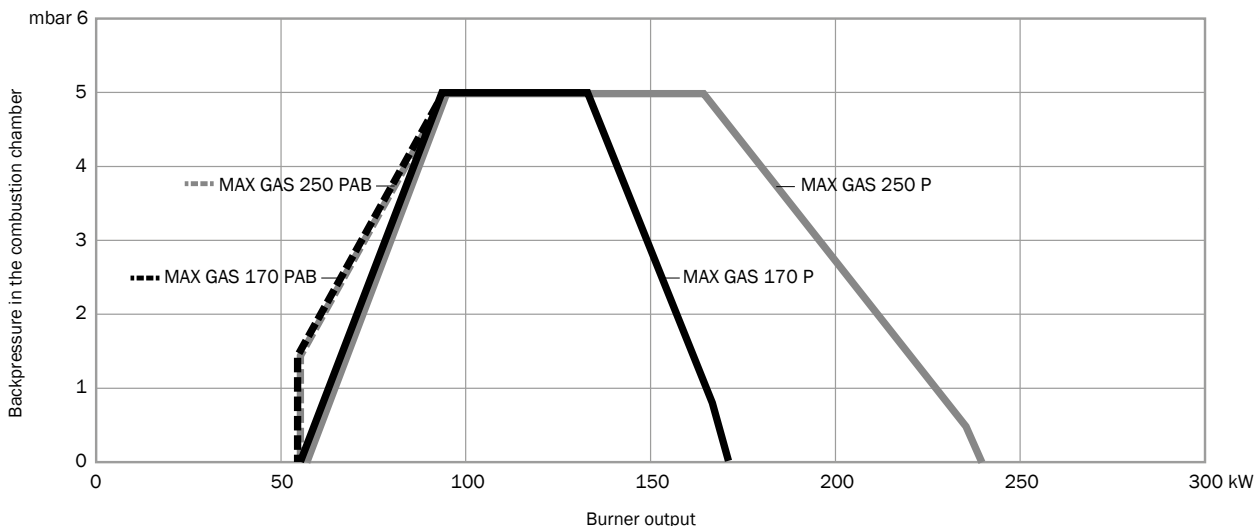
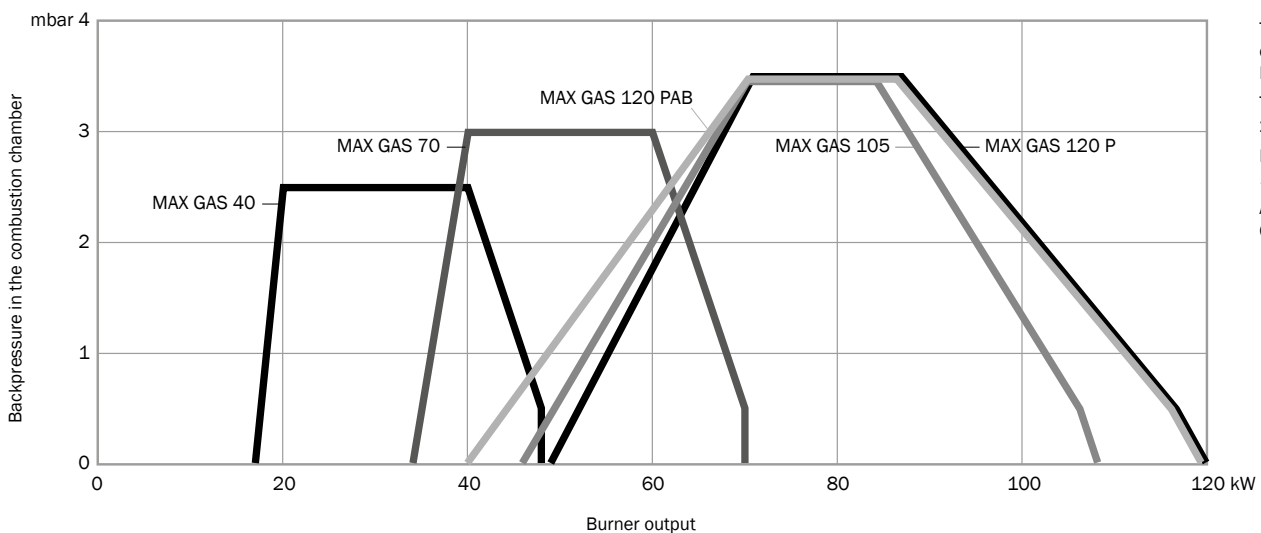

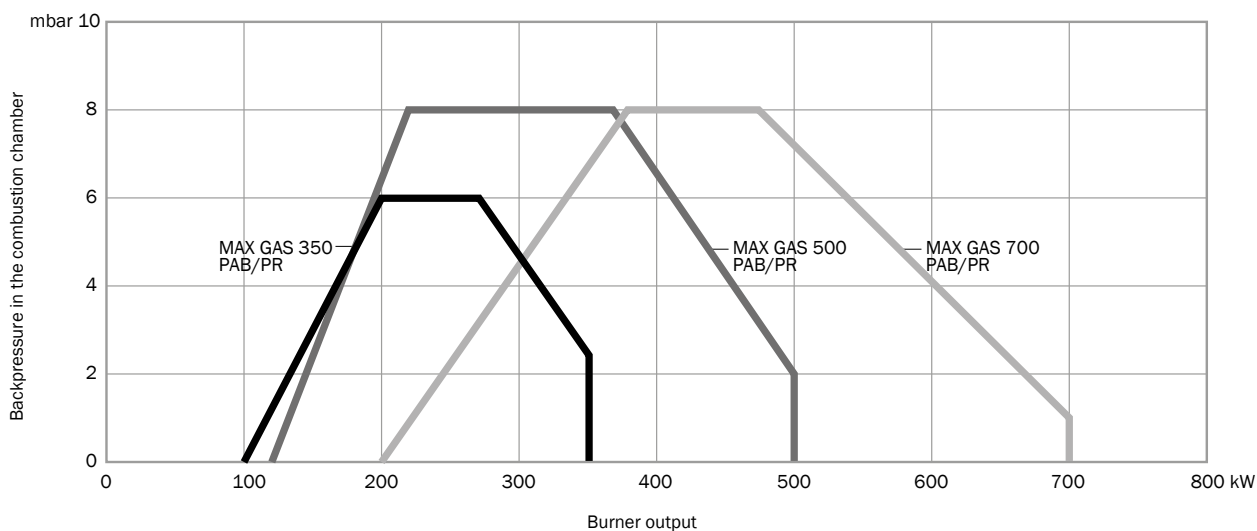
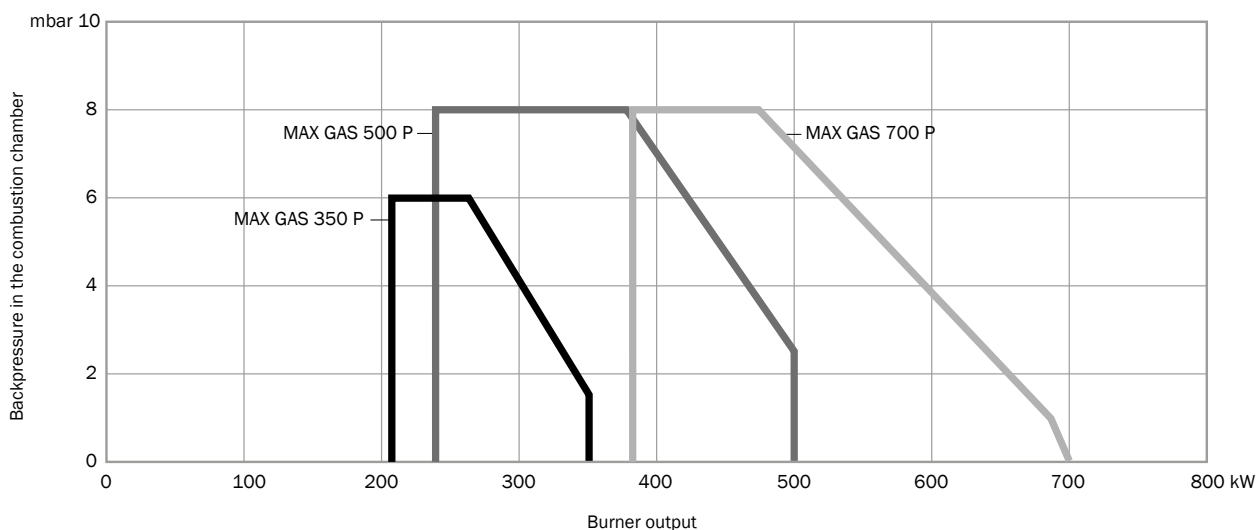

TECHNICAL DATA

Model	Operation	Output (kW)	Control box	Flame detector	Power supply	Motor (W)	Emissions
MAX GAS 40	P	17 - 48	TEG111 / LME21	Ionization	1/230V/50-60Hz	75	Class 3
MAX GAS 70	P	34 - 70	TEG111 / LME21	Ionization	1/230V/50-60Hz	75	Class 3
MAX GAS 105	P	46 - 108	TEG111 / LME21	Ionization	1/230V/50-60Hz	75	Class 3
MAX GAS 120	P	49 - 120	TEG111 / LME21	Ionization	1/230V/50-60Hz	75	Class 3
	PAB	40 - 120	LME22		1/230V/50-60Hz	75	Class 3
MAX GAS 170	P	55 - 170	TEG111 / LME21	Ionization	1/230V/50Hz	200	Class 3
	PAB		TCG2 / LME22				
MAX GAS 250	P	55 - 240	TEG111 / LME21	Ionization	1/230V/50Hz	200	Class 3
	PAB		TCG2 / LME22				
MAX GAS 350	P	205 - 350	TEG111 / LME21	Ionization	1/230V/50Hz	300	Class 3
	PAB	100 - 350	TCG2 / LME22				
	PR	100 - 350	LME22				
MAX GAS 500	P	240 - 500	TEG111 / LME21	Ionization	3/230-400V/50Hz	550	Class 3
	PAB	120 - 500	TCG2 / LME22				
	PR	120 - 500	LME22				
MAX GAS 700 LN	P	380 - 700	TEG111	Ionization	3/230-400V/50Hz	750	Class 3
	PAB	200 - 700	TCG2 / LME22				
	PR	200 - 700	LME22				

CODES

■ P - One stage, Low NOx

Model	Ariston BCU		Siemens BCU	
	TC	TL	TC	TL
MAX GAS 40 P	3142741	3142742	3123932	3123933
MAX GAS 70 P	3142743	3142744	3123934	3123935
MAX GAS 105 P	3142745	3142746	3123936	3123937
MAX GAS 120 P	3142747	3142748	3123938	3123939
MAX GAS 170 P	3142749	3142750	3123940	3123941
MAX GAS 250 P	3142751	3142752	3123942	3123943
MAX GAS 350 P	3143283	3143284	3142283	3142284
MAX GAS 500 P	3143285	3143286	3142289	3142290
MAX GAS 700 LN P	3146269	3146270	-	-

■ PAB - Two stages, Low NOx

Model	Ariston BCU		Siemens BCU	
	TC	TL	TC	TL
MAX GAS 120 PAB	-	-	3123954	3123955
MAX GAS 170 PAB	3142782	3142783	3123956	3123957
MAX GAS 250 PAB	3142784	3142785	3123958	3123959
MAX GAS 350 PAB	3143287	3143288	3142285	3142286
MAX GAS 500 PAB	3143289	3143290	3142291	3142292
MAX GAS 700 LN PAB	3146306	3146307	3146308	3146309

■ PR - Two stage progressive/modulating mechanical, Low NOx

Model	Ariston BCU		Siemens BCU	
	TC	TL	TC	TL
MAX GAS 350 PR	-	-	3142287	3142288
MAX GAS 500 PR	-	-	3142293	3142294
MAX GAS 700 LN PR	-	-	3146345	3146346

OTHER AVAILABLE CONFIGURATIONS

- High temperature (HT)
- Continuous ventilation (CV)
- Post-purge
- OEM and other special versions on request according to feasibility



All non-standard configurations are available on request: contact us to know more

OVERALL DIMENSIONS

i Dimensions in mm
Head length: TC short / TL long

■ MAX GAS 40

■ MAX GAS 70/105/120

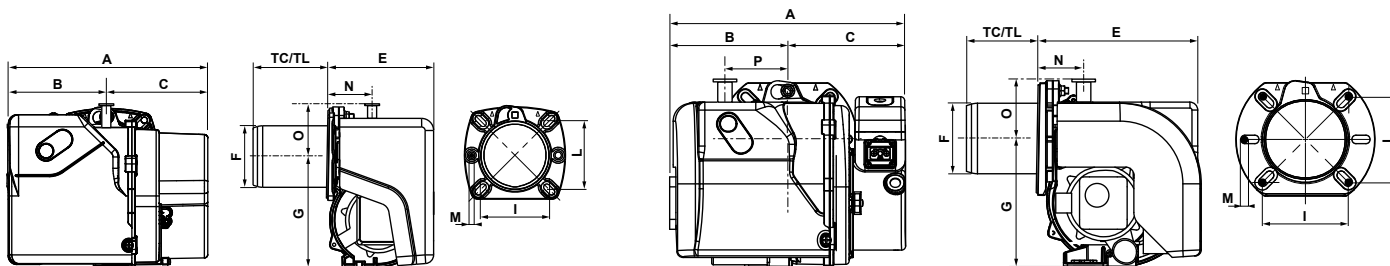

Model	A	B	C	TC	TL	E	F	G	I	L	M	N	O	P
MAX GAS 40 P	288	143	145	85	185	153	89	160	92/107	92/107	M8	54	73	-
MAX GAS 70 P	303	155	148	85	185	204	89	160	100/120	100/120	M8	52	71	82
MAX GAS 105 P	317	169	148	140	220	204	89	160	100/120	100/120	M8	52	71	82
MAX GAS 120 P	317	169	148	160	240	204	98	160	100/120	100/120	M8	52	71	82
MAX GAS 120 PAB	317	169	148	160	240	282	98	160	100/120	100/120	M8	52	71	82

■ MAX GAS 170/250 P

■ MAX GAS 170/250 PAB/PR

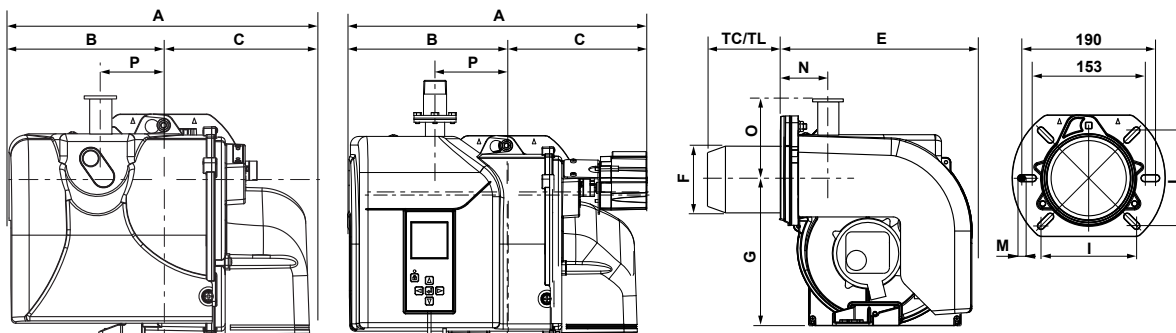

Model	A	B	C	TC	TL	E	F	G	I	L	M	N	O	P
MAX GAS 170/250 P	392	202	190	180	280	280	125	201	106/130	106/130	M8	73	110	104
MAX GAS 170/250 PAB	435	231	204	180	280	301	125	201	106/130	106/130	M8	73	110	104

■ MAX GAS 350...700

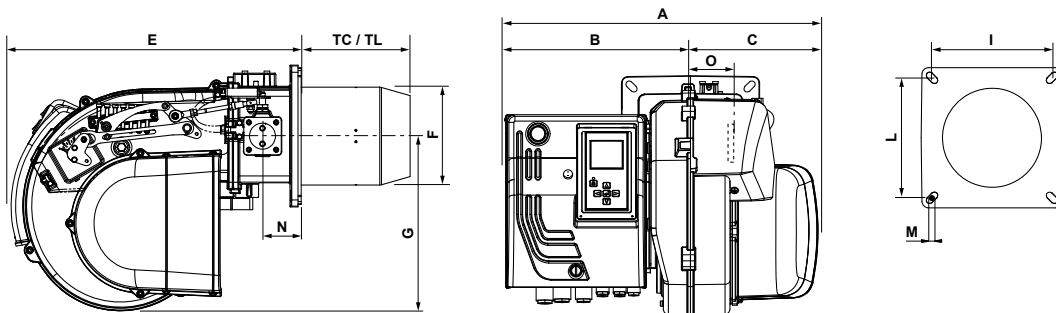

Model	A	B	C	TC	TL	E	F	G	I	L	M	N	O
MAX GAS 350/500 P	485	277	208	175	335	466	157	280	185/200	185/200	M8	62	101
MAX GAS 350/500 PAB	510	302	208	175	335	500	157	280	185/200	185/200	M8	62	101
MAX GAS 350/500 PR	510	302	208	175	335	500	157	280	185/200	185/200	M8	62	101
MAX GAS 700 LN P	485	277	208	250	390	466	190	280	185/200	185/200	M8	62	101
MAX GAS 700 LN PAB TW	510	302	208	250	390	510	190	280	185/200	185/200	M8	62	101
MAX GAS 700 LN PAB	485	277	208	250	390	466	190	280	185/200	185/200	M8	62	101
MAX GAS 700 LN PR	510	302	208	250	390	510	190	280	185/200	185/200	M8	62	101

PACKAGING

The complete burner with gas train and filter is delivered in a carton box containing boiler fixing accessories and a bag with technical documentation.

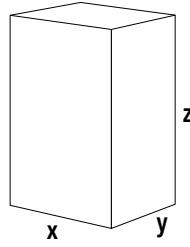

Model	x	y	z	kg
MAX GAS 40	380	400	270	8,5
MAX GAS 70	380	490	270	9
MAX GAS 105	380	490	270	9,5
MAX GAS 120 P	385	490	270	9,5
MAX GAS 120 PAB	385	490	270	10
MAX GAS 170	380	680	510	16
MAX GAS 250	380	680	510	16
MAX GAS 350	500	1020	600	25
MAX GAS 500	500	1020	600	29
MAX GAS 700	500	1020	600	33

Dimensions in **mm**.

Values referred to burners in standard version; the dimensions of the package may vary according to the configuration chosen

GAS TRAINS

■ Natural gas (G20, G25):

Model	Pressure (mbar)		Model	Size	Code	Adapter kit ¹
	min	max				
for MAX GAS 40 P	9	65	MBC 65 DLE	1/2"	3141885	-
	9	200	MB-DLE 403	1/2"	3123944	-
for MAX GAS 70 P	10	360	MB-DLE 405	3/4"	3123560	-
	11	360	MBC 120 DLE	3/4"	3141886	-
	16	65	MBC 65 DLE	1/2"	3141885	-
	18	200	MB-DLE 403	1/2"	3123944	-
for MAX GAS 105 P	16	360	MB-DLE 405	3/4"	3123560	-
	18	360	MBC 120 DLE	3/4"	3141886	-
	34	65	MBC 65 DLE	1/2"	3141885	-
for MAX GAS 120 P	36	200	MB-DLE 403	1/2"	3123944	-
	16	360	MB-DLE 405	3/4"	3123560	-
	18	360	MBC 120 DLE	3/4"	3141886	-
for MAX GAS 170 P	34	65	MBC 65 DLE	1/2"	3141885	-
	13	360	MB-DLE 410	1"	3123947	-
	17	360	MB-DLE 407	3/4"	3123525	-
for MAX GAS 250 P	26	360	MB-DLE 405	3/4"	3123560	3122300
	15	360	MB-DLE 412	1"1/4	3141899	-
	17	360	MB-DLE 410	1"	3123947	-
for MAX GAS 120 PAB	26	360	MB-DLE 407	3/4"	3123525	-
	40	360	MB-DLE 405	3/4"	3123560	3122300
	16	360	MB-ZRDLE 405	3/4"	3123960	-
for MAX GAS 170 PAB	13	360	MB-ZRDLE 410	1"	3123962	-
	17	360	MB-ZRDLE 407	3/4"	3123961	-
	26	360	MB-ZRDLE 405	3/4"	3123960	3122300
for MAX GAS 250 PAB	15	360	MB-ZRDLE 412	1"1/4	3141901	-
	17	360	MB-ZRDLE 410	1"	3123962	-
	26	360	MB-ZRDLE 407	3/4"	3123961	-
for MAX GAS 350 P/PAB/PR	40	360	MB-ZRDLE 405	3/4"	3123960	3122300
	17	360	MB-DLE 415 350/500	1"1/2	3142296	-
	20	360	MB-DLE 412 350/500	1"1/4	3142295	-
	37	360	MB-DLE 410 350/500	1"	3142665	-
for MAX GAS 500 P/PAB/PR	60	360	MB-DLE 407 350/500	3/4"	3142392	-
	20	360	MB-DLE 415 350/500	1"1/2	3142296	-
	35	360	MB-DLE 412 350/500	1"1/4	3142295	-
for MAX GAS LN 700 P/PAB/PR	55	360	MB-DLE 410 350/500	1"	3142665	-
	90	360	MB-DLE 407 350/500	3/4"	3142392	-
	25	360	MB-DLE 415 350/500	1"1/2	3142296	-
for MAX GAS LN 700 ...	40	360	MB-DLE 412 350/500	1"1/4	3142295	-
	60	360	MB-DLE 410 350/500	1"	3142665	-
	95	360	MB-DLE 407 350/500	3/4"	3142392	-

■ LPG (G31):

Model	Pressure (mbar)		Model	Size	Code	Kit LPG ¹	Adapter kit ¹
	min	max					
for MAX GAS 40 P	7	65	MBC 65 DLE	1/2"	3141885	3122301	-
for MAX GAS 70 P	15	65	MBC 65 DLE	1/2"	3141885	3122301	-
for MAX GAS 105 P	24	65	MBC 65 DLE	1/2"	3141885	3122301	-
for MAX GAS 120 P	24	65	MBC 65 DLE	1/2"	3141885	3122301	-
for MAX GAS 170 P	23	360	MB-DLE 405	3/4"	3123560	3122302	3122300
for MAX GAS 250 P	34	360	MB-DLE 405	3/4"	3123560	3122302	3122300
for MAX GAS 120 PAB	15	360	MB-ZRDLE 405	3/4"	3123960	3122301	-
for MAX GAS 170 PAB	23	360	MB-ZRDLE 405	3/4"	3123960	3122302	3122300
for MAX GAS 250 PAB	34	360	MB-ZRDLE 405	3/4"	3123960	3122302	3122300
for MAX GAS 350 ...	33	360	MB-DLE 407 350/500	3/4"	3142392	3142431	-
for MAX GAS 500 ...	52	360	MB-DLE 407 350/500	3/4"	3142392	3142431	-
for MAX GAS LN 700 ...	60	360	MB-DLE 407 350/500	3/4"	3142392	3146026	-

! ¹: to be included in case of order
Gas governor and filter are included

GAS TRAINS - DIMENSIONS

■ MAX GAS 40 ... 250

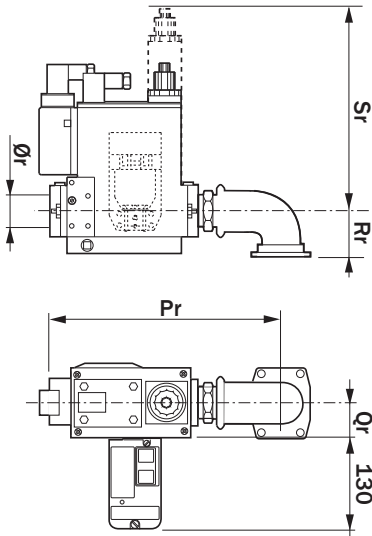

■ MAX GAS 350 ... 700

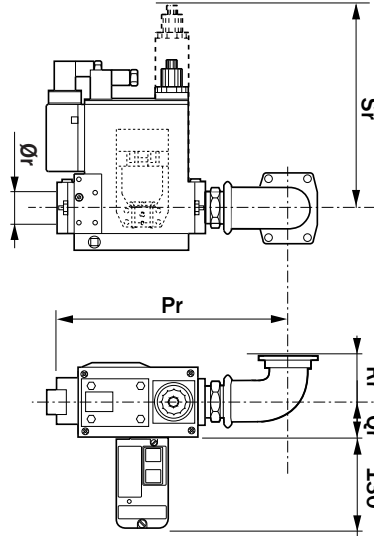

Code	Description	Ø	Dimensions (mm)				
			Pr	Qr	Rr	Sr	Ør
3123525	GT-D1-MBDLE407-RP20-MAXGAS170-250	3/4"	194	55	55	140	3/4"
3123560	GT-D1-MBDLE405-RP20-MAXGAS40-120	3/4"	194	55	35	140	3/4"
3123944	GT-D1-MBDLE403-RP15-MAXGAS40-120	1/2"	150	29	35	144	1/2"
3123947	GT-D1-MBDLE410-RP25-MAXGAS170-250	1"	218	62	55	160	1"
3123960	GT-D2-MBZRDLE405-RP20-MAXGAS40-120	3/4"	194	50	35	210	3/4"
3123961	GT-D2-MBZRDLE407-RP20-MAXGAS170-250	3/4"	194	62	55	210	3/4"
3123962	GT-D2-MBZRDLE410-RP25-MAXGAS170-250	1"	223	62	55	260	1"
3141885	GT-D1-MBC65DLE-RP15-MAXGAS40-120	1/2"	250	42	35	140	1/2"
3141886	GT-D1-MBC120DLE-RP15-MAXGAS40-120	1/2"	260	42	35	140	1/2"
3141899	GT-D1-MBDLE412-RP32-MAXGAS170-250	1"1/4	218	62	55	160	1"1/4
3141901	GT-D2-MBZRDLE412-RP32-MAXGAS170-250	1"1/4	223	62	55	260	1"1/4
3142295	GT-D1-MBDLE412-RP32-MAXGAS350-500	1"1/4	335	62	150	160	1"1/4
3142296	GT-D1-MBDLE415-RP40-MAXGAS350-500	1"1/2	400	50	150	175	1"1/2
3142392	GT-D1-MBDLE407-RP20-MAXGAS350-500	3/4"	335	55	150	140	3/4"
3142665	GT-D1-MBDLE410-RP25-MAXGAS350-500	1"	335	62	150	160	1"

■ EXPORT CONFIGURATION (single solenoid valve with minimum gas pressure switch)

Code	Description	Ø	Dimensions (mm)				
			Pr	Qr	Rr	Sr	Ør
3141888	GT-H1-E6GSRP-RP15-MAXGAS40-120	1/2"	155	55	35	100	1/2"
3141887	GT-H1-EG12L-RP15-MAXGAS40-120	1/2"	145	40	35	155	1/2"
3142815	GT-K1-VAS125-RP25-MAXGAS170-250	1"	169	97	85	210	1"
3142816	GT-K1-VAS240-RP40-MAXGAS170-250	1"1/2	203	80	85	218	1"1/2

GAS TRAINS - TOTAL DIMENSIONS CALCULATION

MAX GAS 40 ... 250

MAX GAS 350 ... 700

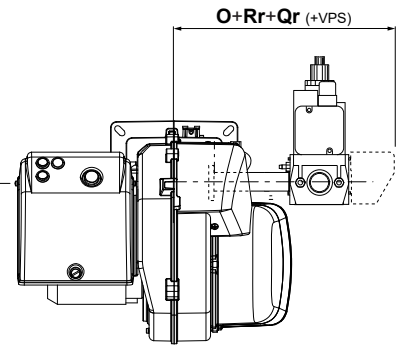
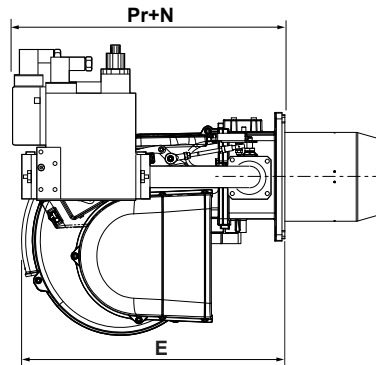
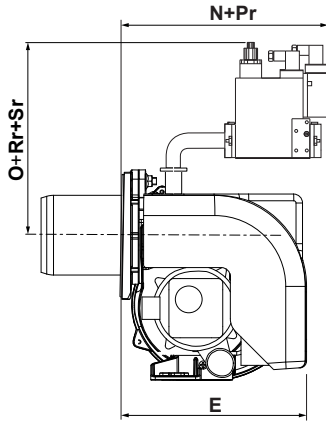

To calculate the overall dimensions, consider the greater value between E and N+Pr

ADAPTER KIT



Code	Models
3122300	MAX GAS 170/250

OPTIONS

MODULATING PID CONTROLLER



Description	Code
Kit RWF50 for MAX GAS 70...250 PR	3146829
Kit RWF50 for MAX GAS 350 ... 700 PR	3143713
Kit RWF55 ¹	3143714

! ¹: not applicable to MAX GAS with Ariston BCU and to MAX GAS 40...250 with Siemens BCU

i Kit supplied loose; on-board assembly available upon request
See page 257 for more information on RWF kit features

TEMPERATURE AND PRESSURE PROBES



Description	Code
Water probe, temperature range from 0 to 130 °C	3122316
Steam probe 0 ... 2 bar	3124100
Steam probe 0 ... 4 bar	3122317
Steam probe 0 ... 10 bar	3122318
Steam probe 0 ... 16 bar	3122319
Steam probe 0 ... 25 bar	3834314
Steam probe 0 ... 40 bar	3122320
Probe for external temperature from -35° to 50 °C	3122315
Hot air or liquid probe, temperature range from -50° to 400 °C	3122314
Thermocouple J type, temperature up to 750 °C (for RWF55 only)	3146725

DIAGNOSTIC TOOL FOR ARISTON BURNER CONTROL

Description	Code
TEG111 Diagnostic tool for one stage burners	3142931
PC interface 3.0	3148650

KIT LPG

Description	Models	Code
LPG conversion kit for gas burners	MAX GAS 40 ... 120	3122301
	MAX GAS 170 - 250	3122302
	MAX GAS 350 - 500	3142431

TIGHTNESS CONTROL



Description	Code
Kit VPS504 for MB-DLE/MB-ZRDLE valves, working with natural gas ²	3122303
Kit VPS504 for MB-DLE/MB-ZRDLE valves, working with LPG ²	3142190
Kit LDU	3142314
Adapter for MAX GAS 70 ... 250 PAB	3142239
Adapter for VPS pilot gas train	3142754

! ²: for MAX GAS 70...250 PAB this kit can only be mounted with the addition of an adapter - see code 3142239

MAXIMUM GAS PRESSURE SWITCH

Description	Output range	Setting range	Code
Kit GPS 50	<6 MW	5 ... 50 mbar	3141921

OPTIONS

GAS GOVERNOR WITH BUILT-IN FILTER

! Default spring is neutral for outlet pressure range 10 - 30 mbar

Size	Maximum gas pressure	Code
Rp1/2"	500 mbar	3142519
Rp3/4"	500 mbar	3142520
Rp1"	500 mbar	3142521
Rp1"1/4	500 mbar	3142522
Rp1"1/2	500 mbar	3142523

SPRINGS FOR GAS GOVERNOR



Description	Size	Gas pressure range	Code
Green spring	1/2", 3/4", 1"	5 ... 15 mbar	3142547
Neutral spring		10 ... 30 mbar	3142548
Violet spring		25 ... 80 mbar	3142549
Brown spring		70 ... 160 mbar	3142550
Blue spring		150 ... 280 mbar	3142551
White spring		270 ... 350 mbar	3142552
Green spring	1"1/4, 1"1/2	5 ... 15 mbar	3142553
Neutral spring		10 ... 30 mbar	3142554
Violet spring		20 ... 70 mbar	3142555
Brown spring		65 ... 130 mbar	3142556
White spring		120 ... 250 mbar	3142557
Black spring		240 ... 350 mbar	3142558

ANTIVIBRATION JOINT



Size	Code
Rp1/2"	3122321
Rp 3/4"	3122322
Rp1"	3122323
Rp1"1/4	3122324
Rp1"1/2	3122325

MANUAL VALVE



Size	Code
Rp1/2"	3158027
Rp 3/4"	3142254
Rp1"	3121430
Rp1"1/4	3142253
Rp1"1/2	3142101

MANOMETER + PUSH BUTTON



Description	Pressure range	Code
Gas manometer 1/2"	0...60 mbar	3142056
Gas manometer 1/4"	0...250 mbar	3142055
Gas manometer 1/4"	0...1000 mbar	3142054
Push button 1/2"		3142057
Push button 1/4"		3142058

- MAX GAS 700 is a monoblock force-draught burner working with natural gas or LPG
- It is equipped with low NOx class 3 ($\text{NOx} \leq 80 \text{ mg/kWh}$) combustion technology in compliance with the EN676 European Standard
- This model is fully electronically controlled for smooth operation and simple and effective programming operation
- MAX GAS 700 is suitable to work with 50 and 60 Hz electrical frequency
- As all the Ecoflam burners it is equipped with an adjustable combustion head for easy regulation and matching with different combustion chambers
- High efficiency fan ventilation system (HPV) allows easy burner-boiler matching even with high combustion chamber pressure
- Multiple gas train matching are available according to the inlet gas pressure
- In these models the regulating gas valve is not fitted in the burner body, but it is part of the gas train



WORKING DIAGRAMS

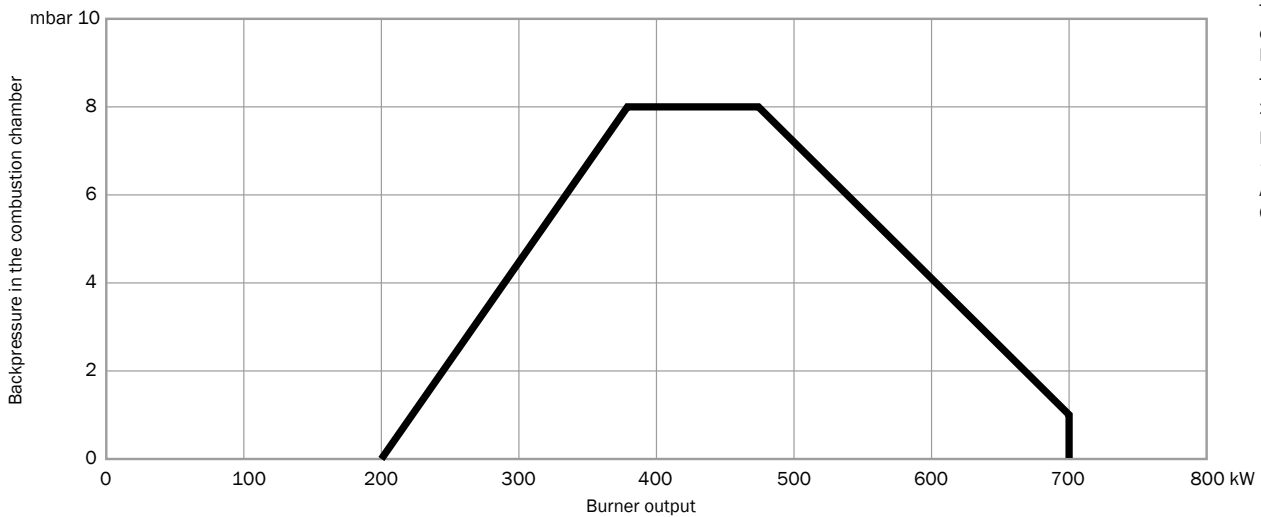

Test conditions conforming to EN676
 Temperature: 20 °C
 Pressure: 1013,5 mbar
 Altitude: 0 m a.s.l.

TECHNICAL DATA

Model	Operation	Output (kW)	Control box	Flame detector	Power supply	Motor (W)	Emissions
MAX GAS 700 LN	PRE	200 - 700	BT320	ionization	3/230-400V/50Hz	750	Class 3

CODES

■ **PRE** - Two stage progressive/modulating electronic, **Low NOx**

Model	TC	TL
MAX GAS 700 LN PRE	3146353	3146354

OTHER AVAILABLE CONFIGURATIONS

- High temperature (HT)
- Continuous ventilation (CV)
- 60 Hz
- Post-purge
- OEM and other special versions on request according to feasibility

i All non-standard configurations are available on request: contact us to know more

PACKAGING

The complete burner with gas train and filter is delivered in a carton box containing boiler fixing accessories and a bag with technical documentation.

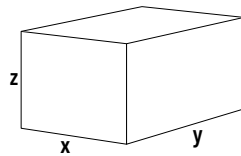

Model	x	y	z	kg
MAX GAS 700 LN	500	1020	600	33

Dimensions in **mm**.
Values referred to burners in standard version; the dimensions of the package may vary according to the configuration chosen

OVERALL DIMENSIONS

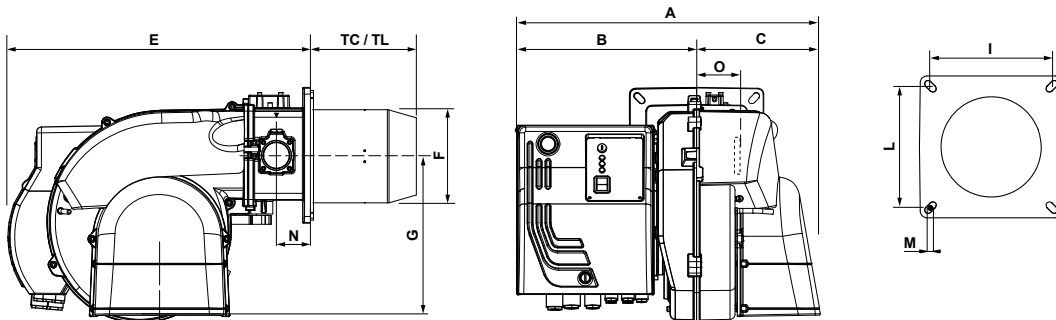

i Dimensions in **mm**
Head length: **TC** short / **TL** long

Model	A	B	C	TC	TL	E	F	G	I	L	M	N	O
MAX GAS 700 LN PRE	510	302	208	250	390	510	190	280	185/200	185/200	M8	62	101

GAS TRAINS

■ Natural gas (G20, G25):

Model	Pressure (mbar)		Model	Size	Code
	min	max			
for MAX GAS 700 LN PRE	24	360	MB-DLE 420 350/500	2"	3149313
	30	360	MB-DLE 415 350/500	1"1/2	3149312
	52	360	MB-DLE 412 350/500	1"1/4	3149311
	84	360	MB-DLE 410 350/500	1"	3149310

! Gas governor and filter are included

GAS TRAINS - DIMENSIONS

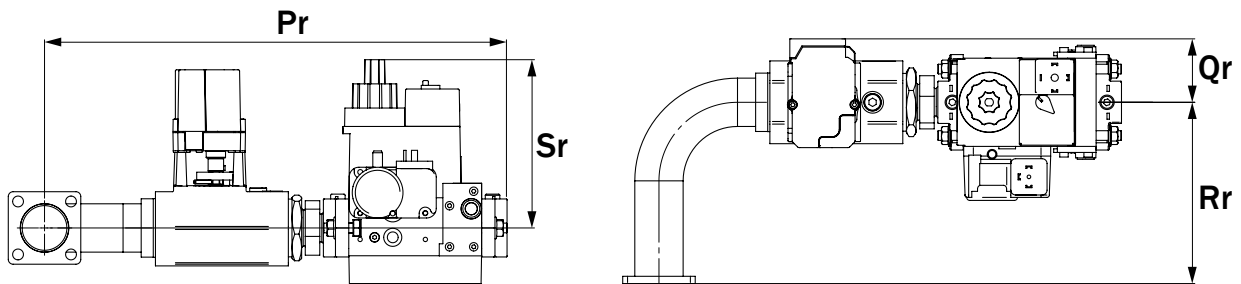

Code	Description	Ø	Dimensions (mm)			
			Pr	Rr	Qr	Sr
3149310	GT-D1-MBDLE410-RP25-PS2-D200	1"	425	150	58	125
3149311	GT-D1-MBDLE412-RP32-PS2-D200	1"1/4	425	150	58	125
3149312	GT-D1-MBDLE415-RP40-PS2-D200	1"1/2	495	150	58	170
3149313	GT-D1-MBDLE420-RP50-PS2-D200	2"	525	150	58	220

GAS TRAINS - TOTAL DIMENSIONS CALCULATION

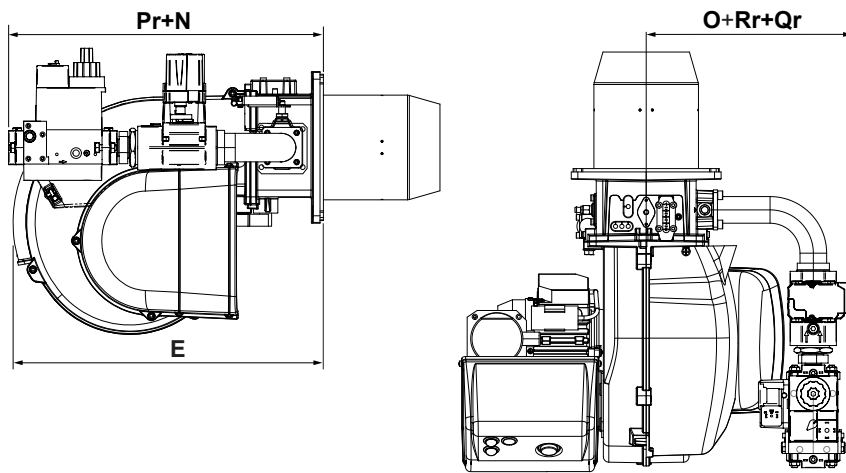

i To calculate the overall dimensions, consider the greater value between E and $N+Pr$

OPTIONS

MODULATING PID CONTROLLER



Description	Code
Kit RWF50	3147786
Kit RWF55	3147787

i Kit supplied loose; on-board assembly available upon request
See page 257 for more information on RWF kit features

TEMPERATURE AND PRESSURE PROBES



Description	Code
Water probe, temperature range from 0 to 130 °C	3122316
Steam probe 0 ... 2 bar	3124100
Steam probe 0 ... 4 bar	3122317
Steam probe 0 ... 10 bar	3122318
Steam probe 0 ... 16 bar	3122319
Steam probe 0 ... 25 bar	3834314
Steam probe 0 ... 40 bar	3122320
Probe for external temperature from -35 ° to 50 °C	3122315
Hot air or liquid probe, temperature range from -50 ° to 400 °C	3122314
Thermocouple J type, temperature up to 750 °C (for RWF55 only)	3146725

MAXIMUM GAS PRESSURE SWITCH

Description	Output range	Setting range	Code
Kit GPS 50	<6 MW	5 ... 50 mbar	3141921

GAS GOVERNOR WITH BUILT-IN FILTER

! Default spring is neutral for outlet pressure range 10 - 30 mbar

Size	Maximum gas pressure	Code
Rp1/2"	500 mbar	3142519
Rp3/4"	500 mbar	3142520
Rp1"	500 mbar	3142521
Rp1"1/4	500 mbar	3142522
Rp1"1/2	500 mbar	3142523

OPTIONS

SPRINGS FOR GAS GOVERNOR

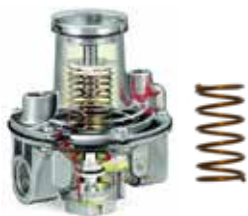

Description	Size	Gas pressure range	Code
Green spring	1/2", 3/4", 1"	5 ... 15 mbar	3142547
Neutral spring		10 ... 30 mbar	3142548
Violet spring		25 ... 80 mbar	3142549
Brown spring		70 ... 160 mbar	3142550
Blue spring		150 ... 280 mbar	3142551
White spring	1"1/4, 1"1/2	270 ... 350 mbar	3142552
Green spring		5 ... 15 mbar	3142553
Neutral spring		10 ... 30 mbar	3142554
Violet spring		20 ... 70 mbar	3142555
Brown spring		65 ... 130 mbar	3142556
White spring	1"1/4, 1"1/2	120 ... 250 mbar	3142557
Black spring		240 ... 350 mbar	3142558

ANTIVIBRATION JOINT



Size	Code
Rp1/2"	3122321
Rp 3/4"	3122322
Rp1"	3122323
Rp1"1/4	3122324
Rp1"1/2	3122325

MANUAL VALVE



Size	Code
Rp1/2"	3158027
Rp 3/4"	3142254
Rp1"	3121430
Rp1"1/4	3142253
Rp1"1/2	3142101

MANOMETER + PUSH BUTTON



Description	Pressure range	Code
Gas manometer 1/2"	0...60 mbar	3142056
Gas manometer 1/4"	0...250 mbar	3142055
Gas manometer 1/4"	0...1000 mbar	3142054
Push button 1/2"		3142057
Push button 1/4"		3142058

RANGE OVERVIEW

Low NOx Classe 3 (NOx ≤ 80 mg/kWh)

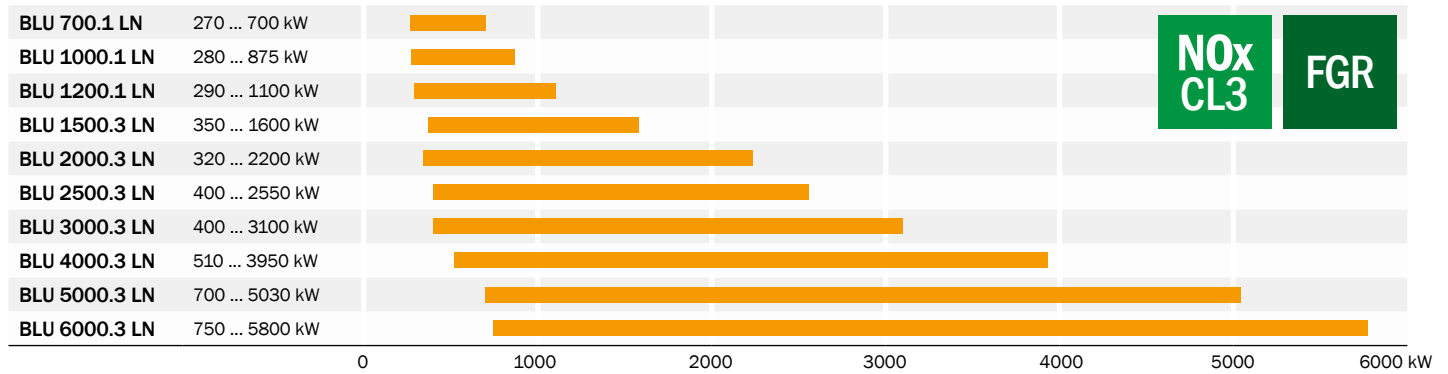

Low NOx Classe 2 (NOx ≤ 120 mg/kWh)

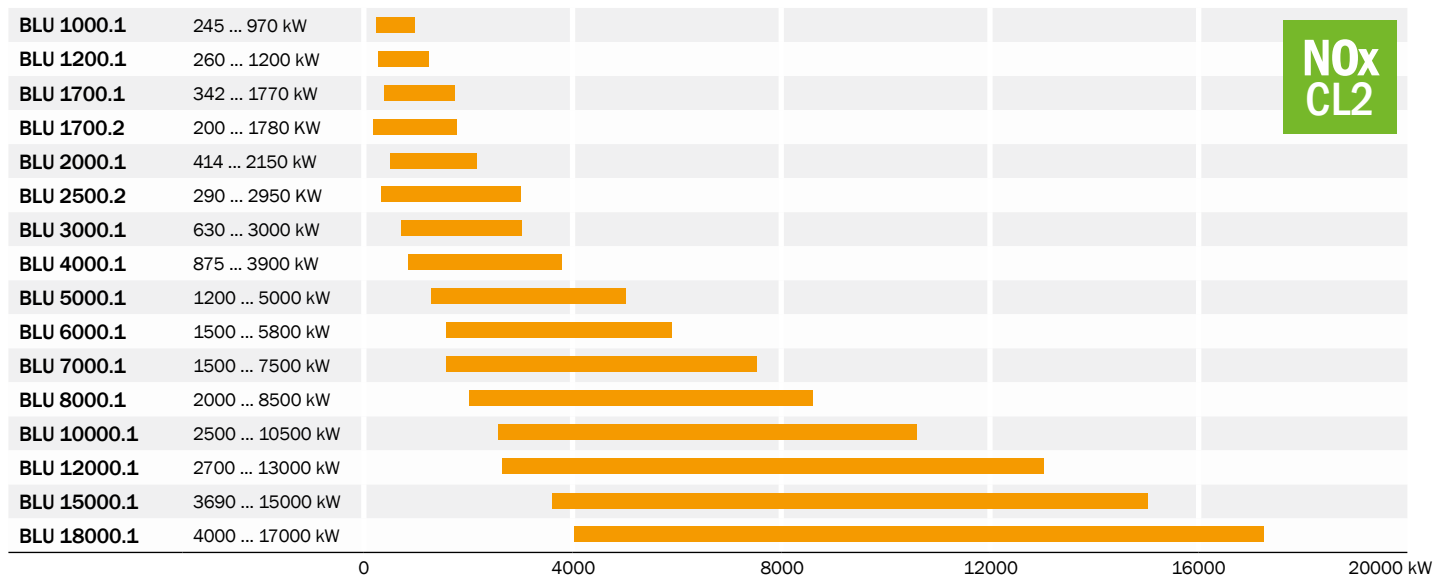

CONFIGURATIONS

BLU range is available in the following operation modes:

BLU PAB	BLU 700 ... 2000 Two stages Low NOx Class 2 and class 3
BLU PR	BLU 700 ... 18000 Two stage progressive/modulating mechanical Low NOx Class 2 and class 3
BLU PRE	BLU 700 ... 18000 Two stage progressive/modulating electronic Low NOx Class 2 and class 3

Other available configurations:

- LPG versions up to BLU 6000
- Continuous ventilation versions
- Swirl system for flame geometry customization
- Version with FGR System to reach Ultra Low NOx emissions (NOx ≤ 30 mg/kWh) - see page 240
- OEM and other special versions on request according to feasibility

MAIN FEATURES

- Adjustable combustion head for easy regulation and matching with different combustion chambers
- Modulating version with PID controller with digital set-point display and real-time values
- Version with fully electronic Burner Management System available for all models
- The range includes burners Low NOx class 2 and Low NOx class 3 up to 6 MW; versions with FGR System (Flue Gas Recirculation) are also available on request and allow to reach NOx emissions below 30 mg/kWh
- The new BLU.3 series has been designed with a new air/gas control system: the servomotor operates directly on the butterfly gas valve and the air damper is controlled through a mechanical leverage connected to the cam; this system allows a more precise regulation of the air damper following the gas valve setting made through the servomotor
- Other configured and special versions are available on request according to feasibility

FUEL

- Natural gas (G20, G25 according to EN676)
- LPG

EMISSIONS

Class	NOx mg/kWh
2	120
3	80

All models are in compliance with EN 676 European Standard

DIRECTIVES

All products are in accordance with the following directives:

- 2014/35/EU Low Voltage Directive
- 2014/30/EU EMC Directive
- 2016/426/EU Gas Appliance Regulation
- 2006/42/EC Machine Directive
- 2011/65/EU RoHS2 Directive

BLU 1000.1
PAB

Two stages
Class 2
245 - 970 kW



BLU 2000.3
LN PRE

Two stage progressive electronic
Low NOx
320 - 2200 kW



BLU 2500.2
PR

Two stage progressive mechanical
Class 2
290 - 2950 kW



BLU 6000.3
LN PRE FGR

Two stage progressive electronic
Ultra low NOx with FGR System
750 - 5800 kW



- BLU LN models from 700.1 to 6000.3 are monoblock force-draught burners working with natural gas or LPG and covering an output range from 270 to 5800 kW
- All models are equipped with low NOx class 3 ($\text{NO}_x \leq 80 \text{ mg/kWh}$) combustion technology in compliance with the EN676 European Standard
- These models are available in two different types of operation:
 - PAB: two stages operation
 - PR: two stage progressive mechanical or modulating with the installation of a power regulator and dedicated probes
- The BLU .3 series has been designed with a new air/gas control system: the servomotor operates directly on the butterfly gas valve and the air damper is controlled through a mechanical leverage connected to the cam; this system allows a more precise regulation of the air damper following the gas valve setting made through the servomotor
- 72H versions are suitable for 72-hour continuous operation without stopping the burner
- Electronic versions are also available: see page 68
- As all the Ecoflam burners they are equipped with an adjustable combustion head for easy regulation and matching with different combustion chambers
- The structure of the burners allow easy access to the internal components for fast start-up and reduced maintenance time and space



WORKING DIAGRAM

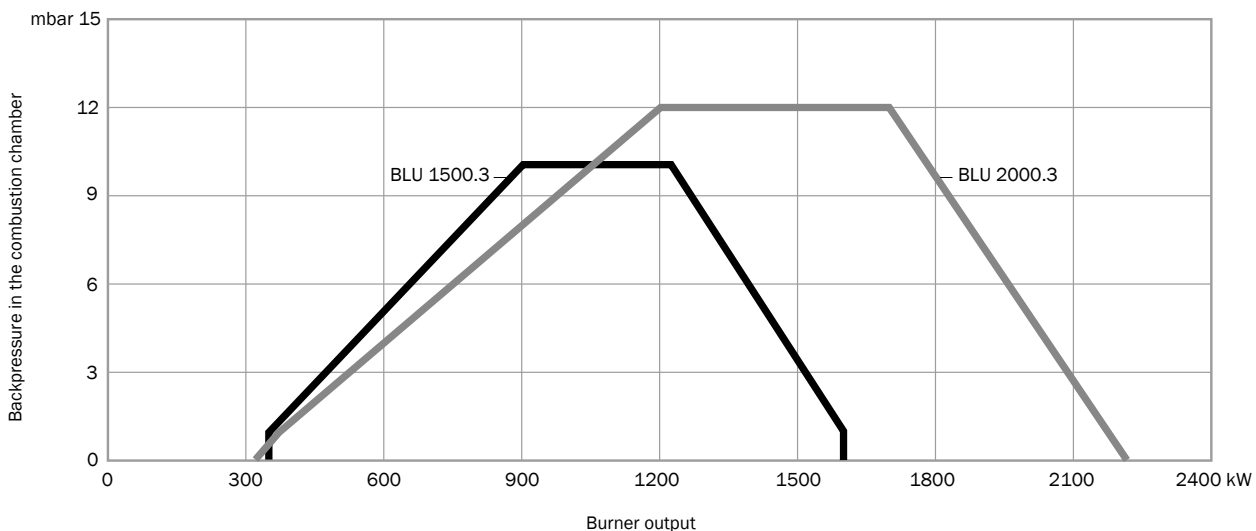
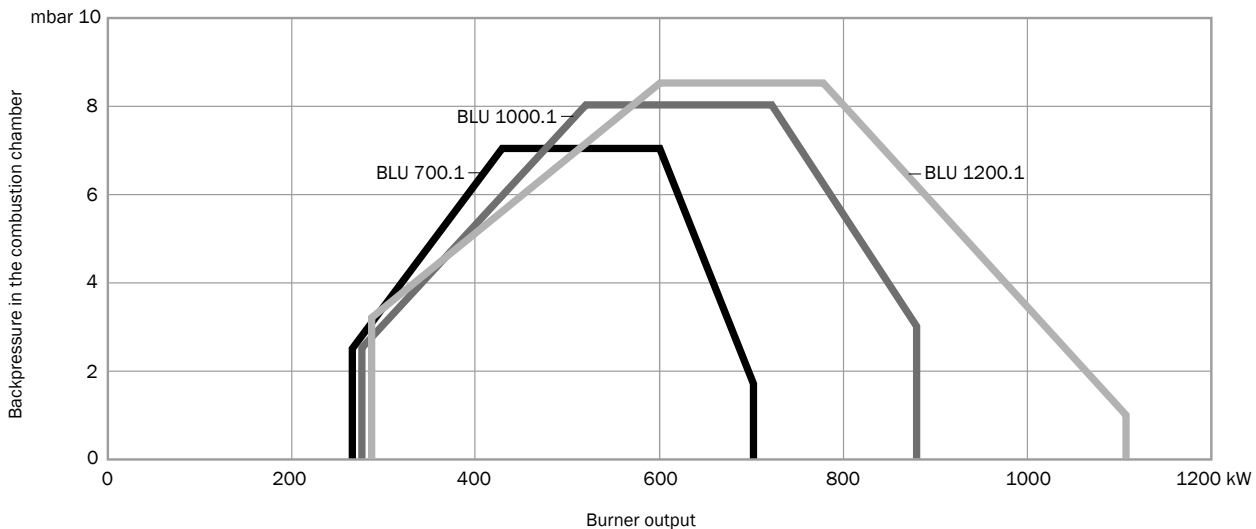

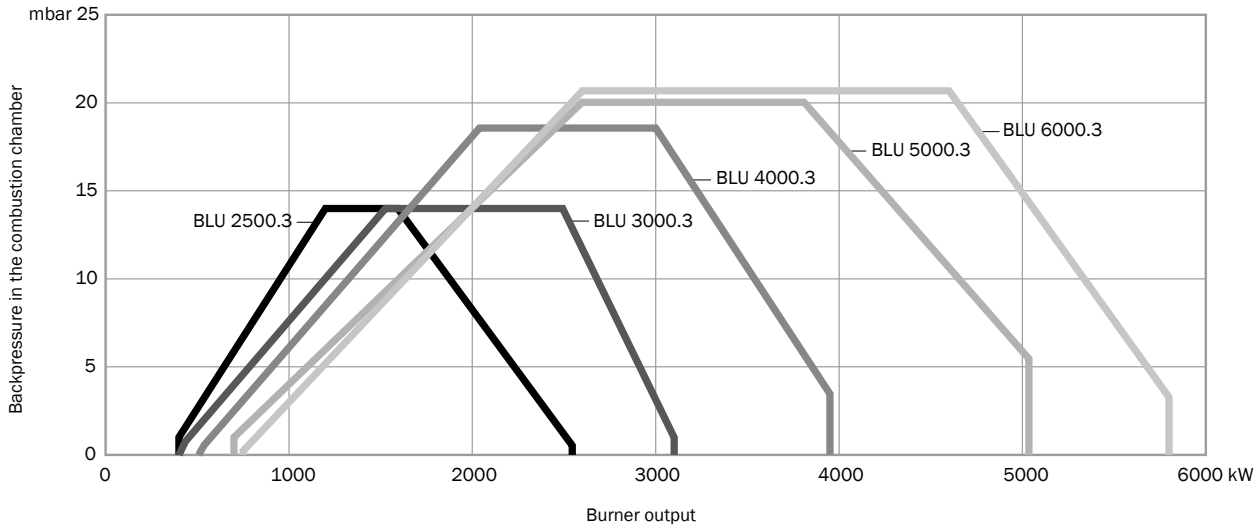

Test conditions conforming to EN676
 Temperature: 20 °C
 Pressure: 1013,5 mbar
 Altitude: 0 m a.s.l.

TECHNICAL DATA

Model	Operation	Output (kW)	Control box	Flame detector	Power supply	Motor (kW)	Emissions
BLU 700.1 LN	PAB PR	270 - 700	LME22	Ionization	3/230-400/50Hz	1,1	Class 3
BLU 1000.1 LN	PAB PR	280 - 875	LME22	Ionization	3/230-400/50Hz	1,1	Class 3
BLU 1200.1 LN	PAB PR	290 - 1100	LME22	Ionization	3/230-400/50Hz	2,2	Class 3
BLU 1500.3 LN	PAB PR PR 72H	350 - 1600	LME22 ¹	Ionization	3/230-400/50Hz	2,2	Class 3
BLU 2000.3 LN	PAB PR PR 72H	320 - 2200	LME22 ¹	Ionization	3/230-400/50Hz	3	Class 3
BLU 2500.3 LN	PR PR 72H	400 - 2550	LME73 ¹	QRA2 ²	3/230-400/50Hz	4	Class 3
BLU 3000.3 LN	PR PR 72H	400 - 3100	LME73 ¹	QRA2 ²	3/230-400/50Hz	5,5	Class 3
BLU 4000.3 LN	PR PR 72H	510 - 3950	LME73 ¹	QRA2 ²	3/230-400/50Hz	7,5	Class 3
BLU 5000.3 LN	PR PR 72H	700 - 5030	LME73 ¹	QRA2 ²	3/230-400/50Hz	11	Class 3
BLU 6000.3 LN	PR PR 72H	750 - 5800	LME73 ¹	QRA2 ²	3/230-400/50Hz	15	Class 3

i ¹: LME75 on 72H versions
²: QRA73 on 72H versions

EMISSIONS

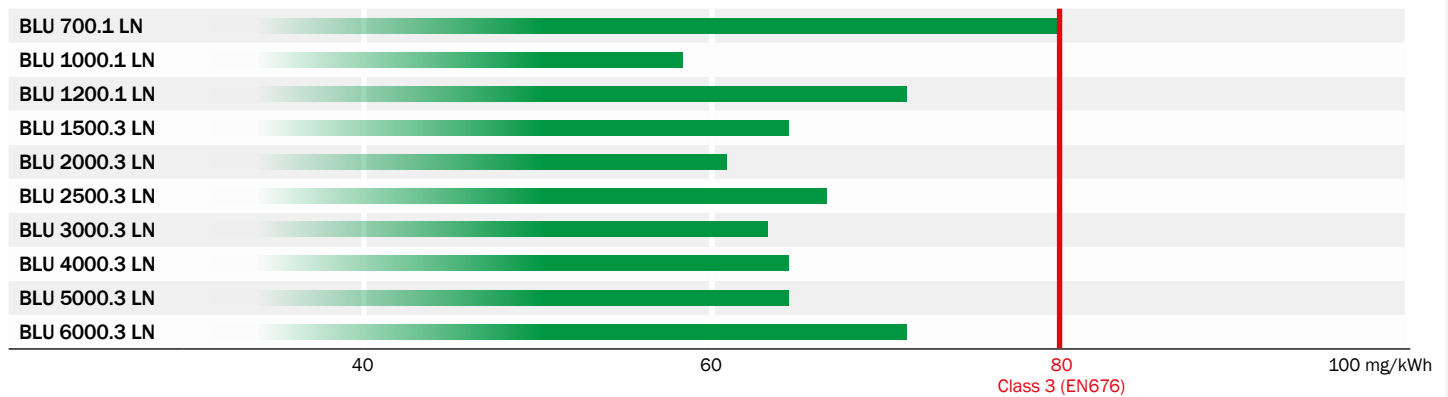

CODES

■ PAB - Two stages, Low NOx

Model	TC	TM	TL
BLU 700.1 LN PAB	3143977	-	3143978
BLU 1000.1 LN PAB	3143988	-	3143989
BLU 1200.1 LN PAB	3143994	-	3143995
BLU 1500.3 LN PAB	3148836	3148837	3148838
BLU 2000.3 LN PAB	3148839	3148840	3148841

■ PR - Two stage progressive/modulating mechanical, Low NOx

Model	TC	TM	TL
BLU 700.1 LN PR	3143984	-	3143985
BLU 1000.1 LN PR	3143990	-	3143991
BLU 1200.1 LN PR	3143996	-	3143997
BLU 1500.3 LN PR	3148842	3148843	3148844
BLU 2000.3 LN PR	3148845	3148846	3148847
BLU 2500.3 LN PR	-	3148849	3148850
BLU 3000.3 LN PR	-	3148852	3148853
BLU 4000.3 LN PR	-	3148855	3148856
BLU 5000.3 LN PR	-	3148858	3148859
BLU 6000.3 LN PR	-	3148861	3148862

■ PR 72H - Two stage progressive/modulating mechanical, 72-hour continuous operation, Low NOx

Model	TC	TM	TL
BLU 1500.3 LN PR 72H	3149186	3149187	3149188
BLU 2000.3 LN PR 72H	3149189	3149190	3149191
BLU 2500.3 LN PR 72H	-	3149193	3149194
BLU 3000.3 LN PR 72H	-	3149196	3149197
BLU 4000.3 LN PR 72H	-	3149199	3149200
BLU 5000.3 LN PR 72H	-	3149202	3149203
BLU 6000.3 LN PR 72H	-	3149205	3149206

OTHER AVAILABLE CONFIGURATIONS

- 60 Hz
- Continuous ventilation (CV)
- Post-purge
- Swirl system for flame geometry customization
- OEM and other special versions on request according to feasibility



All non-standard configurations are available on request: contact us to know more

OVERALL DIMENSIONS

■ BLU 700.1 ... 1200.1 LN PAB

i Dimensions in mm
 Head length: TC short / TM medium / TL long
¹: with silencer (optional)

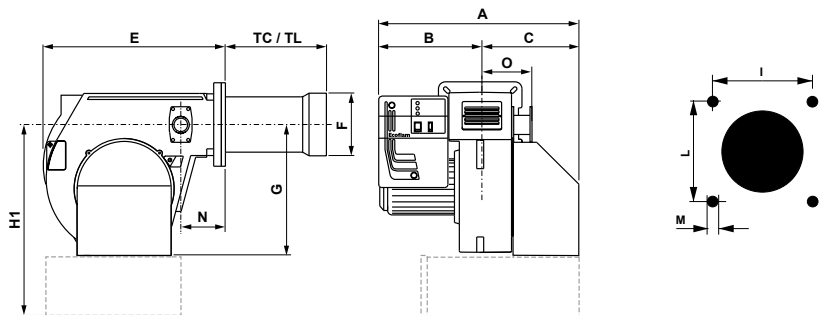

Model	A	B	C	TC	TL	E	F	G	H1 ¹	I	L	M	N	O
BLU 700.1 LN PAB	650	330	320	175	395	555	170	390	600	190	190	M10	140	165
BLU 1000.1 LN PAB	650	330	320	175	395	555	190	390	600	190	190	M10	140	165
BLU 1200.1 LN PAB	670	350	320	310	460	555	200	390	600	190	190	M10	140	165

■ BLU 1500.3 LN PAB

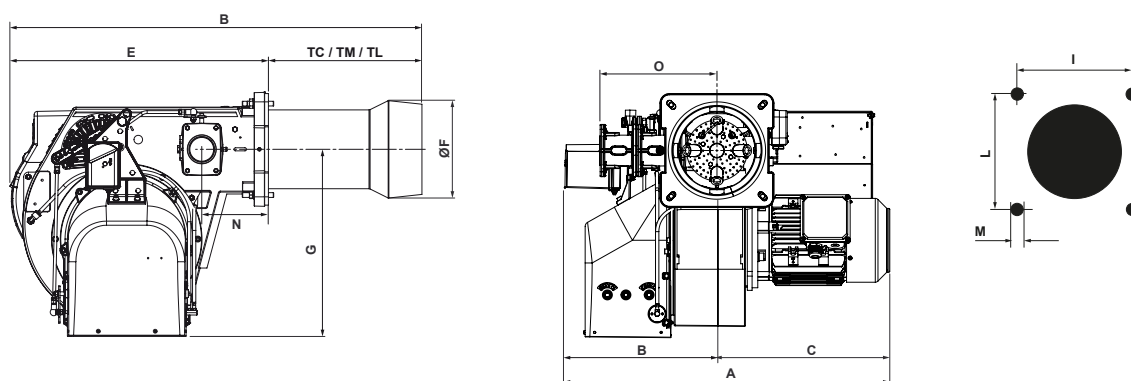

Model	A	B	C	TC	TM	TL	E	ØF	G	I	L	M	N	O
BLU 1500.3 LN PAB	677	313	364	345	445	545	543	205	401	185/200	185/200	M10	138	168

■ BLU 2000.3 LN PAB

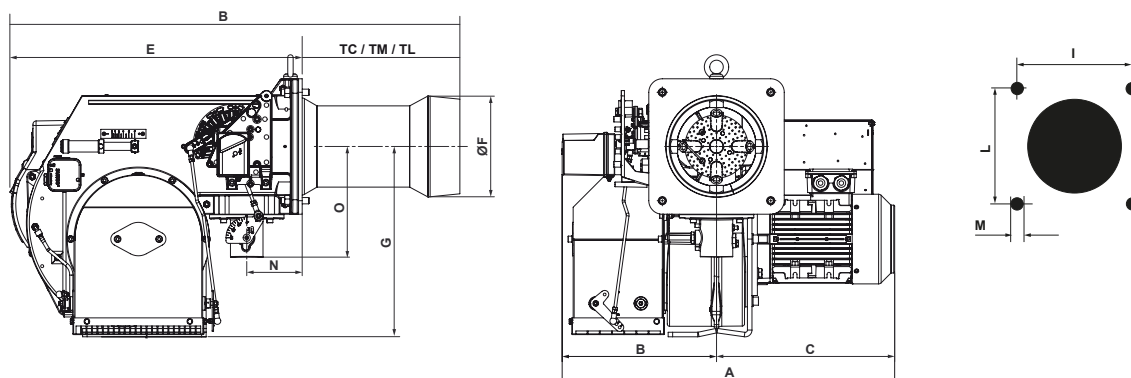

Model	A	B	C	TC	TM	TL	E	ØF	G	I	L	M	N	O
BLU 2000.3 LN PAB	728	331	397	345	445	545	647	224	420	240	240	M14	125	245

■ BLU 700.1 ... 1500.3 LN PR

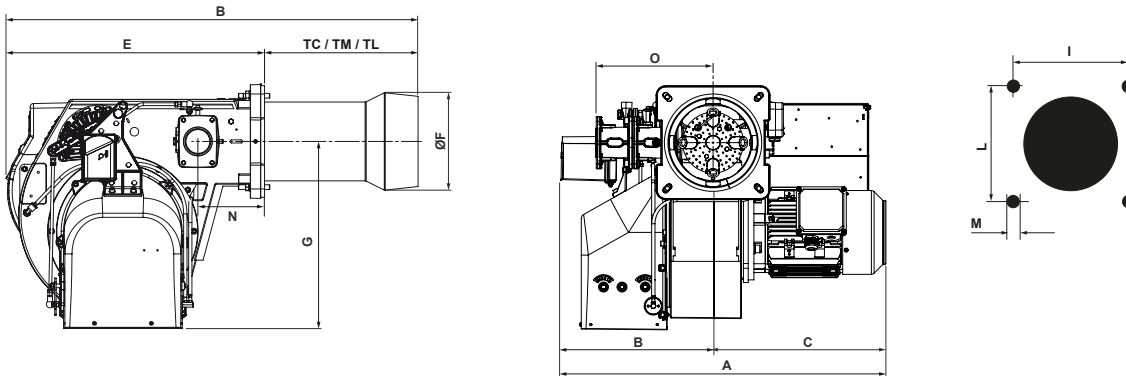

Model	A	B	C	TC	TM	TL	E	F	G	I	L	M	N	O
BLU 700.1 LN PR	657	329	328	174	-	394	543	170	401	185/200	185/200	M10	138	420
BLU 1000.1 LN PR	657	329	328	174	-	394	543	190	401	185/200	185/200	M10	138	420
BLU 1200.1 LN PR	657	329	328	309	-	459	543	200	401	185/200	185/200	M10	138	420
BLU 1500.3 LN PR	677	313	364	345	445	545	543	205	401	185/200	185/200	M10	138	168

■ BLU 2000.3 ... 6000.3 LN PR

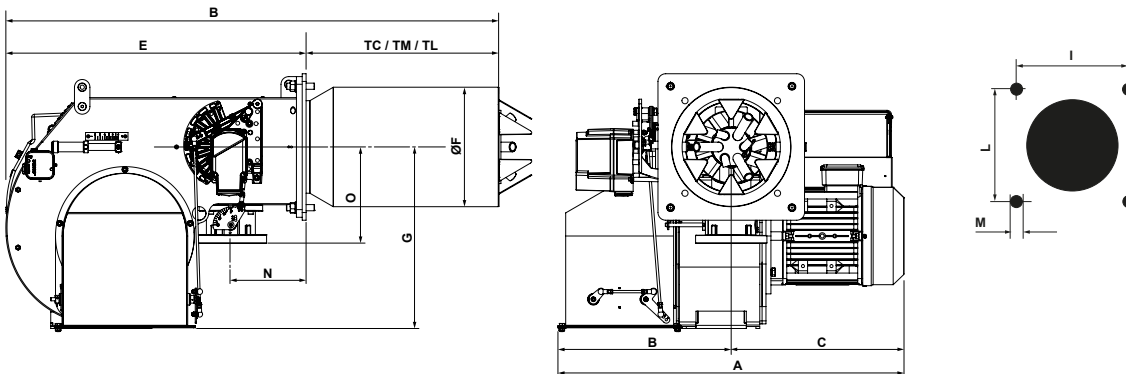

Model	A	B	C	TC	TM	TL	E	F	G	I	L	M	N	O
BLU 2000.3 LN PR	728	331	397	345	445	545	647	224	420	240	240	M14	125	245
BLU 2500.3 LN PR	791	367	424	-	540	640	675	263	420	315	315	M16	133	245
BLU 3000.3 LN PR	873	470	403	-	550	650	779	263	469	315	315	M16	195	245
BLU 4000.3 LN PR	898	450	448	-	550	650	779	310	469	315	315	M16	195	250
BLU 5000.3 LN PR	1122	526	596	-	560	690	930	310	570	330	330	M16	195	250
BLU 6000.3 LN PR	1122	526	596	-	560	690	930	325	570	330	330	M16	195	250

PACKAGING

The complete burner with gas train and filter is delivered in a carton box containing boiler fixing accessories and a bag with technical documentation.

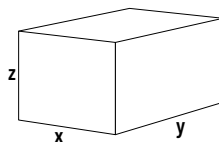

Model	x	y	z	kg
BLU 700.1 LN	800	1070	590	50
BLU 1000.1 LN	800	1070	590	54
BLU 1200.1 LN	800	1070	590	62
BLU 1500.3 LN	800	1070	590	113
BLU 2000.3 LN	930	1300	760	113
BLU 2500.3 LN	930	1300	760	120
BLU 3000.3 LN	1150	1700	930	170
BLU 4000.3 LN	1150	1700	930	180
BLU 5000.3 LN	1250	1780	980	250
BLU 6000.3 LN	1590	1590	1080	270

Dimensions in mm.
 Values referred to burners in standard version; the dimensions of the package may vary according to the configuration chosen

GAS TRAINS

Model	Pressure (min - max)	Model	Size	Code	Connection pipe	Gas governor and filter
for BLU 700.1 LN	17 - 360	MB-DLE 420	2"	3141847	-	included
	25 - 360	MB-DLE 415	1"1/2	3141846		included
	45 - 360	MB-DLE 412	1"1/4	3141845		included
	75 - 360	MB-DLE 410	1"	3142022		included
for BLU 1000.1 LN	35 - 360	MB-DLE 420	2"	3141847	-	included
	40 - 360	MB-DLE 415	1"1/2	3141846		included
	75 - 360	MB-DLE 412	1"1/4	3141845		included
for BLU 1200.1 LN	20 - 500	VDG 20.503	2"	3123860	-	3121384
	35 - 360	MB-DLE 420	2"	3141847		included
	45 - 360	MB-DLE 415	1"1/2	3141846		included
	85 - 360	MB-DLE 412	1"1/4	3141845		included
for BLU 1500.3 LN	20 - 500	VDG 40.065	DN65	3147131	3147159	3124111
	45 - 500	VDG 20.503	2"	3147130	-	3121384
for BLU 2000.3 LN	23 - 500	VDG 40.080	DN80	3147132	3148772	3142088
	35 - 500	VDG 40.065	DN65	3147131	3148771	3124111
	60 - 500	VDG 20.503	2"	3147130	3144686	3121384
for BLU 2500.3 LN	40 - 500	VDG 40.080	DN80	3146006	3148772	3142088
	48 - 500	VDG 40.065	DN65	3146005	3148771	3124111
	82 - 500	VDG 20.503	2"	4399022	3144686	3121384
for BLU 3000.3 LN	22 - 500	VDG 40.100	DN100	3146007	3148773	3142205
	35 - 500	VDG 40.080	DN80	3146006	3148772	3142088
	55 - 500	VDG 40.065	DN65	3146005	3148771	3124111
	100 - 500	VDG 20.503	2"	4399022	3144686	3121384
for BLU 4000.3 LN	30 - 500	VDG 40.100	DN100	3146007	3148768	3142205
	50 - 500	VDG 40.080	DN80	3146006	3148767	3142088
	90 - 500	VDG 40.065	DN65	3146005	3148766	3124111
	170 - 500	VDG 20.503	2"	4399022	3148770	3121384
for BLU 5000.3 LN	35 - 500	VDG 40.125	DN125	3146008	3148769	3142206
	45 - 500	VDG 40.100	DN100	3146007	3148768	3142205
	75 - 500	VDG 40.080	DN80	3146006	3148767	3142088
	140 - 500	VDG 40.065	DN65	3146005	3148766	3124111
	250 - 500	VDG 20.503	2"	4399022	3148770	3121384
for BLU 6000.3 LN	50 - 500	VDG 40.125	DN125	3146008	3148769	3142206
	60 - 500	VDG 40.100	DN100	3146007	3148768	3142205
	100 - 500	VDG 40.080	DN80	3146006	3148767	3142088
	180 - 500	VDG 40.065	DN65	3146005	3148766	3124111
	340 - 500	VDG 20.503	2"	4399022	3148770	3121384

! For minimum inlet pressures higher than 250 mbar, choose the pressure switch GW500 (to be fitted during installation on site)
For gas trains in EN676 Configuration a tightness control device must be included over 1200 kW

GAS TRAINS - DIMENSIONS

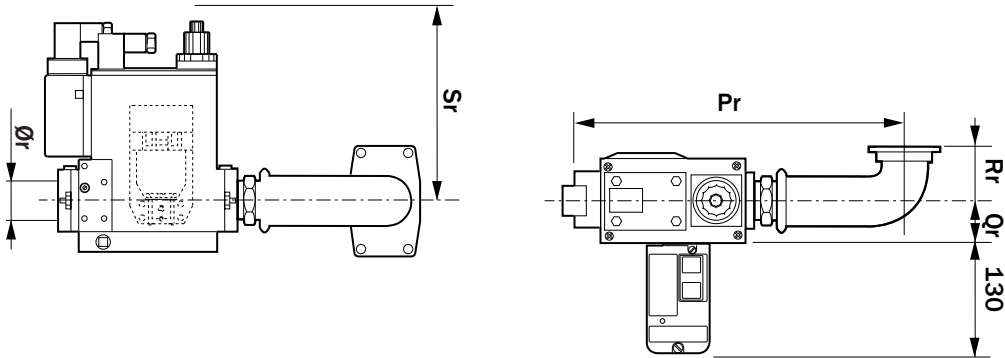

Code	Gas train	Ø	Dimensions (mm)				
			Pr	Qr	Rr	Sr	Ør
3142022	GT-D1-MBDLE410-RP25-BLU/MULTI	Rp1"	330	62	85	160	1"
3141845	GT-D1-MBDLE412-RP32-BLU/MULTI	Rp1"1/4	330	62	85	160	1"1/4
3141846	GT-D1-MBDLE415-RP40-BLU/MULTI	Rp1"1/2	410	50	85	175	1"1/2
3141847	GT-D1-MBDLE420-RP50-BLU/MULTI	Rp2"	420	50	85	175	2"

■ **TOTAL DIMENSIONS CALCULATION**

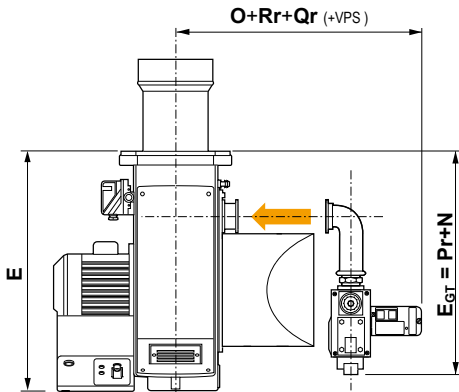

i To calculate the overall dimensions, consider the greater value between E and E_{GT}

GAS TRAINS - DIMENSIONS

■ VGD 20...

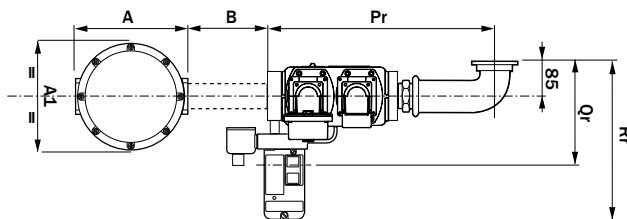
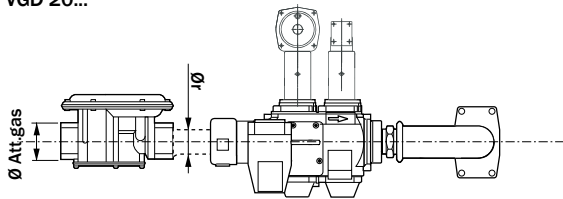

Code	Gas train	Ø	Dimensions (mm)			
			Pr	Qr	Rr	Ør
3123860	GT-S1-VGD20-RP50-BLU/MULTI	Rp2"	450	185	315	2"

■ VGD 20... PS1-S

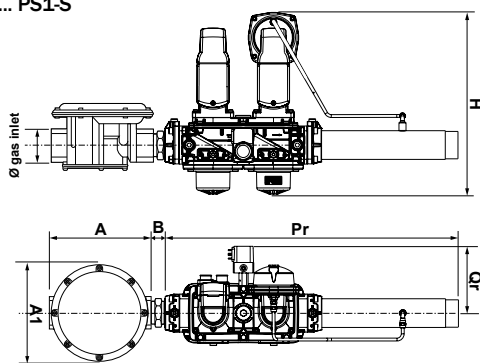

■ VGD 40... PS1-S

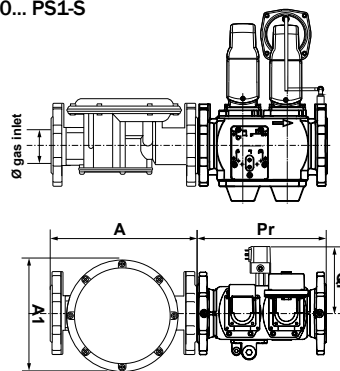

Code	Gas train	Ø	Dimensions (mm)			
			Pr	Qr	H	B
3147130	GT-S1-VGD20-RP50-PS1-S	Rp2"	689	34,9	382	36
3147131	GT-S1-VGD40-DN65-PS1-S	DN65	290	125,8	421	-
3147132	GT-S1-VGD40-DN80-PS1-S	DN80	310	127,3	445	-

■ VGD 20... PS3

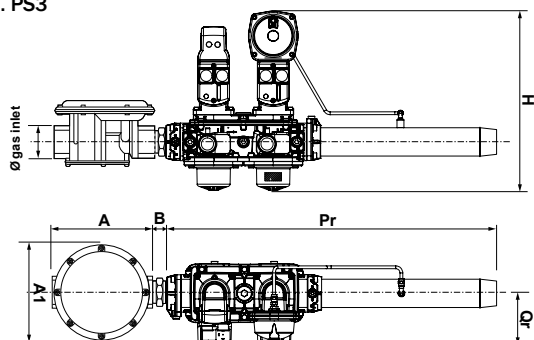

■ VGD 40... PS3

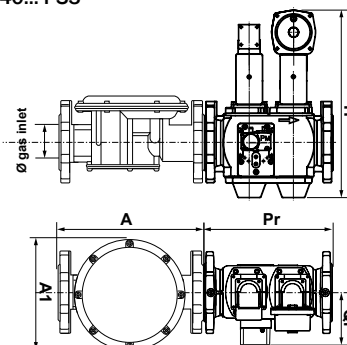

Code	Gas train	Ø	Dimensions (mm)		
			Pr	Qr	H
4399022	GT-S1-VGD20-RP50-PS3	Rp2"	606	105	385
3146005	GT-S1-VGD40-DN65-PS3	DN65	290	127,3	421
3146006	GT-S1-VGD40-DN80-PS3	DN80	310	127,3	445
3146007	GT-S1-VGD40-DN100-PS3	DN100	350	145,4	476
3146008	GT-S1-VGD40-DN125-PS3	DN125	400	158,4	524

GAS TRAINS - DIMENSIONS

CONNECTION PIPE

Code	Pic.	Dimensions (mm)		
		T	U	V
3144686	1	100	32	-
3147159	4	-	500	-
3148766	2	122	778	145
3148767	2	145	778	120
3148768	2	145	778	120
3148769	2	145	788	157
3148770	3	108	58	
3148771	5	100	602	106
3148772	5	100	602	125
3148773	5	100	602	125
3149594	6	100	507	-

1

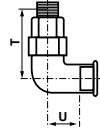

2

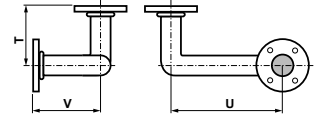

3

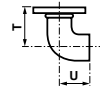

4

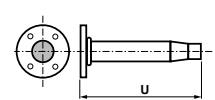

5

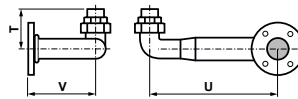

6

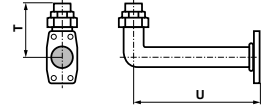

GAS FILTER

Code	Ø	Dimensions (mm)		
		A	A1	B
3121384	Rp2"	186	186	>100
3124111	DN65	290	212	-
3142088	DN80	320	240	-
3142205	DN100	380	280	-
3142206	DN125	380	280	-

GAS TRAINS - DIMENSIONS

TOTAL DIMENSIONS CALCULATION

BLU 700.1 ... 1200.1

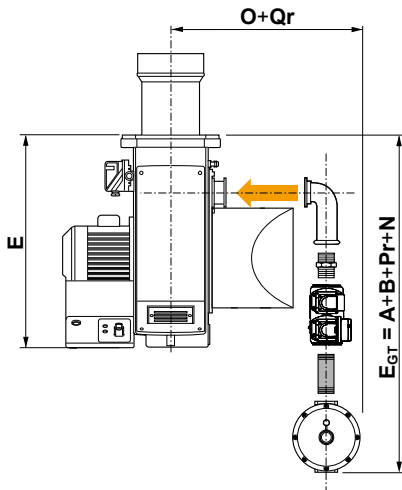

BLU 1500.3

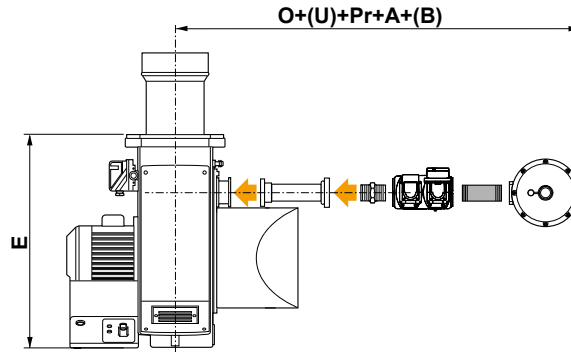

BLU 2000.3 ... 6000.3

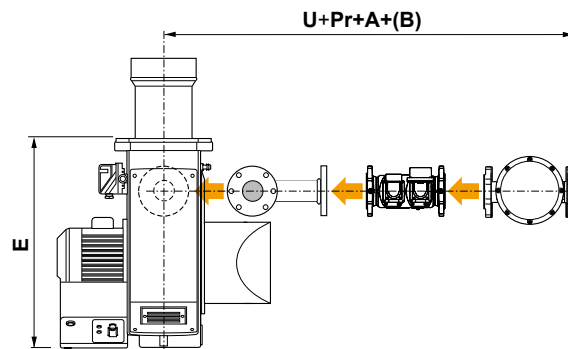
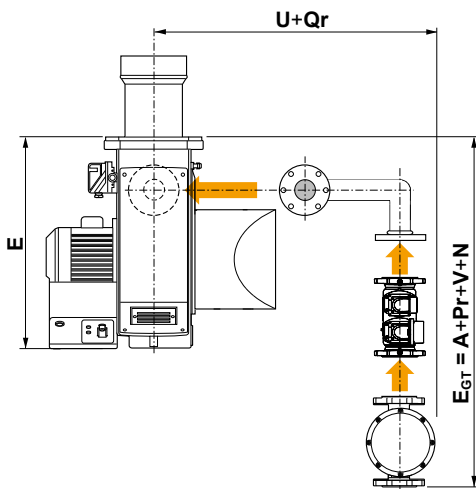

i To calculate the overall dimensions, consider the greater value between E and E_{GT}

OPTIONS**MODULATING
PID CONTROLLER**

Description	Code
Kit RWF50	3143713
Kit RWF55 for BLU 700.1 ... 1200.1	3143714
Kit RWF55 for BLU 1500.3 ... 6000.3	3147787

i Kit supplied loose; on-board assembly available upon request
See page 257 for more information on RWF kit features

**TEMPERATURE AND
PRESSURE PROBES**

Description	Code
Water probe, temperature range from 0 to 130 °C	3122316
Steam probe 0 ... 2 bar	3124100
Steam probe 0 ... 4 bar	3122317
Steam probe 0 ... 10 bar	3122318
Steam probe 0 ... 16 bar	3122319
Steam probe 0 ... 25 bar	3834314
Steam probe 0 ... 40 bar	3122320
Probe for external temperature from -35 ° to 50 °C	3122315
Hot air or liquid probe, temperature range from -50 ° to 400 °C	3122314
Thermocouple J type, temperature up to 750 °C (for RWF55 only)	3146725

**CUSTOMER INTERFACE
KIT DISPLAY**

Description	Code
Kit display AZL21 for burners equipped with Siemens LME7	3148779

**FREQUENCY
CONVERTER**

Description	Code	
IP21 with: • EMC filter • Inductor • Control panel	3 kW	3757054
	4 kW	3757055
	5,5 kW	3757056
	7,5 kW	3757057
	11 kW	3757058
	15 kW	3757059
IP55 with: • EMC filter • Inductor • Control panel	3 kW	3757067
	4 kW	3757068
	5,5 kW	3757069
	7,5 kW	3757070
	11 kW	3757071
	15 kW	3757072

OPTIONS**TIGHTNESS CONTROL**

! For gas trains in EN676 Configuration a tightness control device must be included over 1200 kW

Description	Code
Kit VPS504 for MB-DLE/MB-ZRDLE and VGD DN65/80/100 valves, working with natural gas	3122303
Kit VPS504 for MB-DLE/MB-ZRDLE and VGD DN65/80/100 valves, working with LPG	3142190
Kit VPS504 for VGD20.503 valve, working with natural gas	3122305
Kit VPS504 for VGD20.503 valve, working with LPG	3142688
Kit VDK for VGD valves, DN125/DN150 size	3141922
Kit LDU	3142314
Adapter for VPS pilot gas train	3142754

KIT LPG

Description	Models	Code
LPG conversion kit for gas burners	BLU 700.1 LN / 1000.1 LN / 1200.1 LN	3144610
	BLU 1500.3 LN	3149576
	BLU 2000.3 LN	3149577
	BLU 2500.3 LN / 3000.3 LN	3149288
	BLU 4000.3 LN	3149289
	BLU 5000.3 LN / 6000.3 LN	3149290

MAXIMUM GAS PRESSURE SWITCH

Description	Output range	Setting range	Code
Kit GPS 50	<6 MW	5...50 mbar	3141921

GAS GOVERNOR WITH BUILT-IN FILTER

! Default spring is neutral for outlet pressure range 10 - 30 mbar

Size	Maximum gas pressure	Code
Rp1"	500 mbar	3142521
Rp1"1/4	500 mbar	3142522
Rp1"1/2	500 mbar	3142523
Rp2"	500 mbar	3142524
Rp2"	1 bar	3142051
DN65	1 bar	3141983
DN80	1 bar	3142538
DN100	1 bar	on request
DN125	1 bar	on request

OPTIONS

SPRINGS FOR GAS GOVERNOR

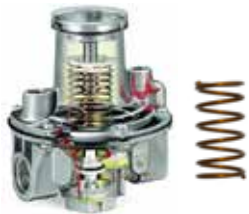

Description	Size	Gas pressure range	Code
Green spring	1/2", 3/4", 1"	5 ... 15 mbar	3142547
Neutral spring		10 ... 30 mbar	3142548
Violet spring		25 ... 80 mbar	3142549
Brown spring		70 ... 160 mbar	3142550
Blue spring		150 ... 280 mbar	3142551
White spring		270 ... 350 mbar	3142552
Green spring	1"1/4, 1"1/2	5 ... 15 mbar	3142553
Neutral spring		10 ... 30 mbar	3142554
Violet spring		20 ... 70 mbar	3142555
Brown spring		65 ... 130 mbar	3142556
White spring		120 ... 250 mbar	3142557
Black spring		240 ... 350 mbar	3142558
Green spring	2"	5 ... 15 mbar	3142559
Neutral spring		10 ... 30 mbar	3142560
Violet spring		30 ... 80 mbar	3142561
Brown spring		70 ... 220 mbar	3142562
Blue spring		210 ... 350 mbar	3142563
Red spring	DN65, DN80	25-80 mbar	3144252
Violet spring		60-120 mbar	3144253
Blue spring		100-220 mbar	3144254
White spring		200-450 mbar	3144255
Red spring	DN100	30-70 mbar	3144256
Violet spring		60-110 mbar	3144257
Brown spring		100-210 mbar	3144258
White spring		200-450 mbar	3144060

GAS FILTER



Size	Code
Rp1"	3142046
Rp1"1/2	3141954
Rp2"	3121384
DN65	3124111
DN80	3142088
DN100	3142205
DN125	3142206

ANTIVIBRATION JOINT



Size	Code
Rp1"	3122323
Rp1"1/4	3122324
Rp1"1/2	3122325
Rp2"	3122326
DN65	3142060
DN80	3122328
DN100	3122329
DN125	3142061

OPTIONS**MANUAL VALVE**

Size	Code
Rp1"	3121430
Rp1"1/4	3142253
Rp1"1/2	3142101
Rp2"	3142102
DN65	3142062
DN80	3143730
DN100	3141997
DN125	3141998

**MANOMETER +
PUSH BUTTON**

Description	Pressure range	Code
Gas manometer 1/2"	0...60 mbar	3142056
Gas manometer 1/4"	0...250 mbar	3142055
Gas manometer 1/4"	0...1000 mbar	3142054
Push button 1/2"		3142057
Push button 1/4"		3142058

- BLU LN models from 700.1 to 6000.3 are monoblock force-draught burners working with natural gas or LPG and covering an output range from 270 to 5800 kW
- All models are equipped with low NOx class 3 ($\text{NOx} \leq 80 \text{ mg/kWh}$) combustion technology in compliance with the EN676 European Standard
- These models are available in two stage progressive electronic configuration with Burner Management System
- All models are fully electronically controlled for smooth operation and simple and effective programming operation
- All models starting from 1500.3 are also available in 72H version, suitable for 72-hour continuous operation without stopping the burner, and in FCA version, equipped with frequency converter arrangement
- A tightness control device is integrated for all electronic burners
- Version with FGR System to reach Ultra Low NOx emissions ($\text{NOx} \leq 30 \text{ mg/kWh}$) are available: see page 240
- As all the Ecoflam burners they are equipped with an adjustable combustion head for easy regulation and matching with different combustion chambers
- The structure of the burners allow easy access to the internal components for fast start-up and reduced maintenance time and space
- Multiple gas train matching are available according to the inlet gas pressure



WORKING DIAGRAM

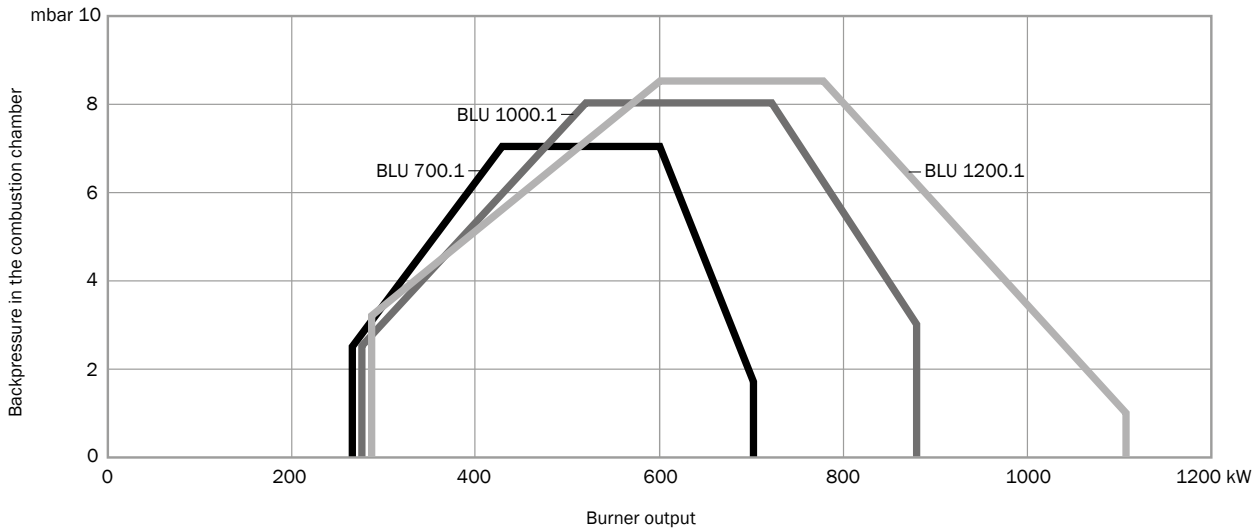

Test conditions conforming to EN676
 Temperature: 20 °C
 Pressure: 1013,5 mbar
 Altitude: 0 m a.s.l.

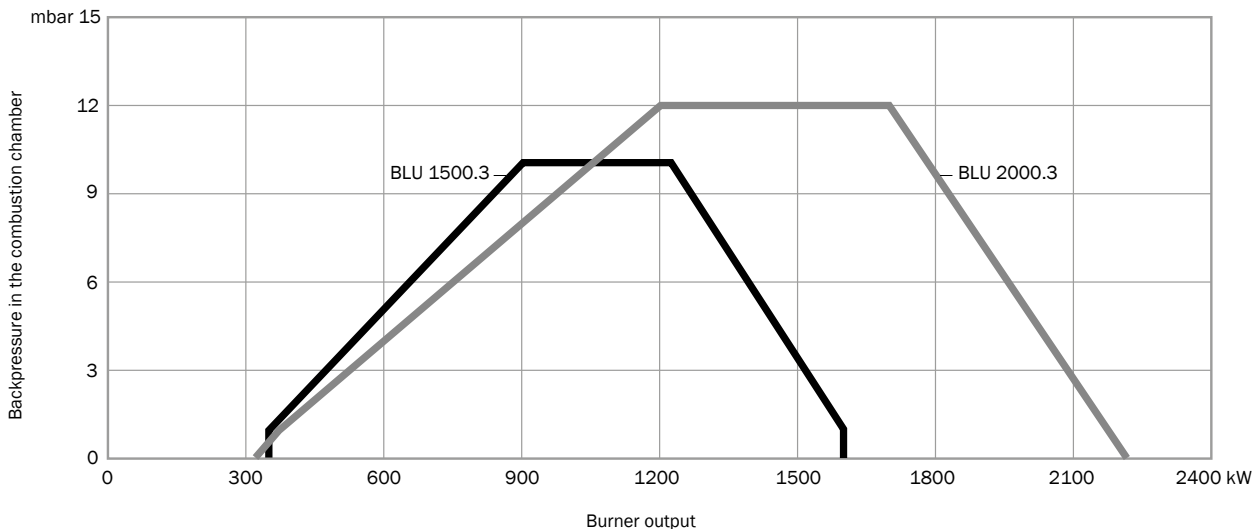

Test conditions conforming to EN676
 Temperature: 20 °C
 Pressure: 1013,5 mbar
 Altitude: 0 m a.s.l.

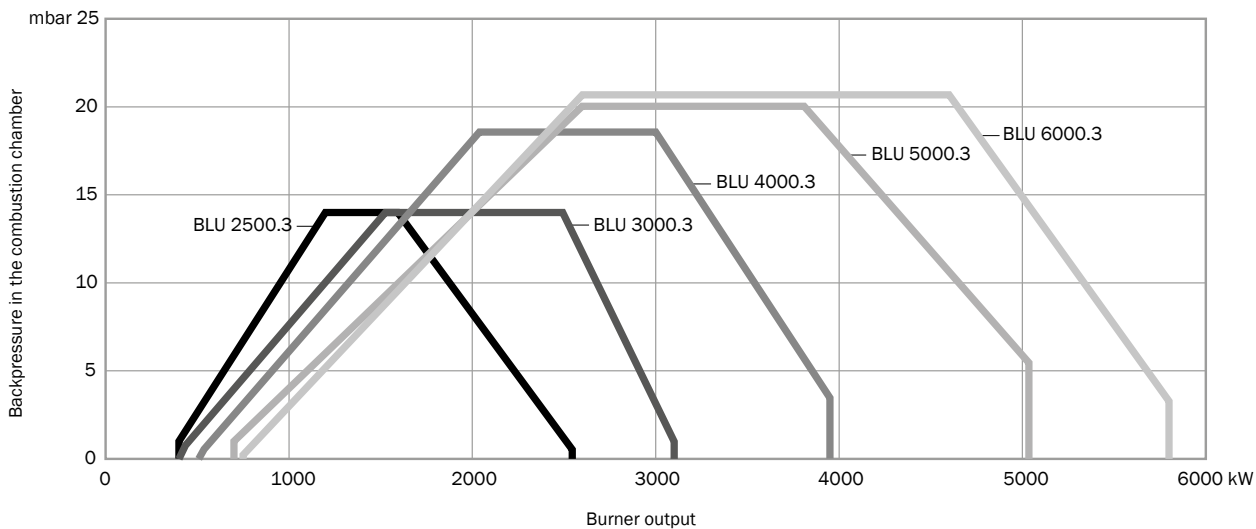

Test conditions conforming to EN676
 Temperature: 20 °C
 Pressure: 1013,5 mbar
 Altitude: 0 m a.s.l.

TECHNICAL DATA

Model	Operation	Output (kW)	Control box	Flame detector	Power supply	Motor (kW)	Emissions
BLU 700.1 LN	PRE	270 - 700	BT320	ionization	3/230-400/50Hz	1,1	Class 3
BLU 1000.1 LN	PRE	280 - 875	BT320	ionization	3/230-400/50Hz	1,1	Class 3
BLU 1200.1 LN	PRE	290 - 1100	BT320	ionization	3/230-400/50Hz	2,2	Class 3
BLU 1500.3 LN	PRE FCA 72H FCA 72H	350 - 1600	BT320	ionization	3/230-400/50Hz	2,2	Class 3
BLU 2000.3 LN	PRE FCA 72H FCA 72H	320 - 2200	BT320	ionization	3/230-400/50Hz	3	Class 3
BLU 2500.3 LN	PRE FCA 72H FCA 72H	400 - 2550	BT320 ¹	QRA2 ²	3/230-400/50Hz	4	Class 3
BLU 3000.3 LN	PRE FCA 72H FCA 72H	400 - 3100	BT320 ¹	QRA2 ²	3/230-400/50Hz	5,5	Class 3
BLU 4000.3 LN	PRE FCA 72H FCA 72H	510 - 3950	BT320 ¹	QRA2 ²	3/230-400/50Hz	7,5	Class 3
BLU 5000.3 LN	PRE FCA 72H FCA 72H	700 - 5030	BT320 ¹	QRA2 ²	3/230-400/50Hz	11	Class 3
BLU 6000.3 LN	PRE FCA 72H FCA 72H	750 - 5800	BT320 ¹	QRA2 ²	3/230-400/50Hz	15	Class 3

¹: BT330 on 72H versions
²: FFS08 on 72H versions

EMISSIONS

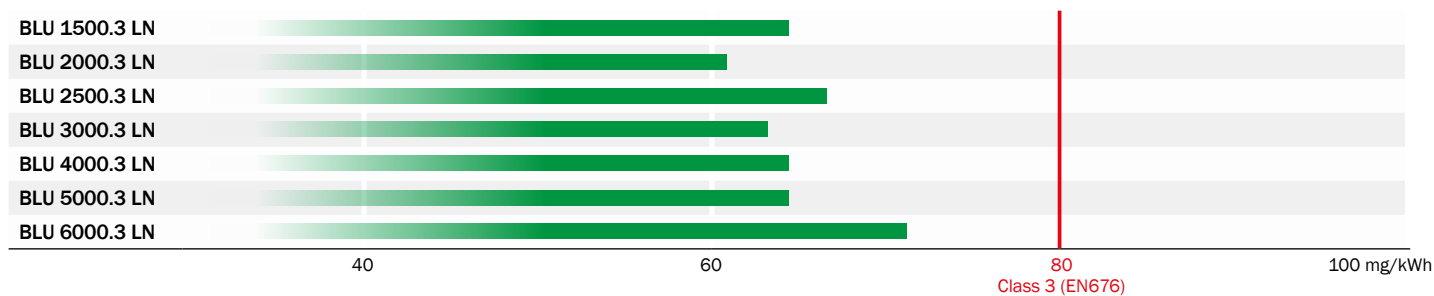

CODES

■ PRE - Two stage progressive/modulating electronic, Low NOx

Model	TC	TM	TL
BLU 700.1 LN PRE	3145108	-	3145109
BLU 1000.1 LN PRE	3145110	-	3145111
BLU 1200.1 LN PRE	3145112	-	3145113
BLU 1500.3 LN PRE	3148863	3148864	3148865
BLU 2000.3 LN PRE	3148866	3148867	3148868
BLU 2500.3 LN PRE	-	3148870	3148871
BLU 3000.3 LN PRE	-	3148873	3148874
BLU 4000.3 LN PRE	-	3148876	3148877
BLU 5000.3 LN PRE	-	3148879	3148880
BLU 6000.3 LN PRE	-	3148882	3148883

■ PRE FCA - Two stage progressive/modulating electronic with frequency converter arrangement, Low NOx

Model	TC	TM	TL
BLU 1500.3 LN PRE FCA	3148884	3148885	3148886
BLU 2000.3 LN PRE FCA	3148887	3148888	3148889
BLU 2500.3 LN PRE FCA	-	3148891	3148892
BLU 3000.3 LN PRE FCA	-	3148894	3148895
BLU 4000.3 LN PRE FCA	-	3148897	3148898
BLU 5000.3 LN PRE FCA	-	3148900	3148901
BLU 6000.3 LN PRE FCA	-	3148903	3148904

■ PRE 72H - Two stage progressive/modulating electronic, 72-hour continuous operation, Low NOx

Model	TC	TM	TL
BLU 1500.3 LN PRE 72H	3149208	3149209	3149210
BLU 2000.3 LN PRE 72H	3149211	3149212	3149213
BLU 2500.3 LN PRE 72H	3149214	3149215	3149216
BLU 3000.3 LN PRE 72H	3149217	3149218	3149219
BLU 4000.3 LN PRE 72H	3149220	3149221	3149222
BLU 5000.3 LN PRE 72H	3149223	3149224	3149225
BLU 6000.3 LN PRE 72H	3149226	3149227	3149228

■ PRE FCA 72H - Two stage progressive/modulating electronic with frequency converter arrangement, 72-hour continuous operation, Low NOx

Model	TC	TM	TL
BLU 1500.3 LN PRE FCA 72H	3149229	3149230	3149231
BLU 2000.3 LN PRE FCA 72H	3149232	3149233	3149234
BLU 2500.3 LN PRE FCA 72H	3149235	3149236	3149237
BLU 3000.3 LN PRE FCA 72H	3149238	3149239	3149240
BLU 4000.3 LN PRE FCA 72H	3149241	3149242	3149243
BLU 5000.3 LN PRE FCA 72H	3149244	3149245	3149246
BLU 6000.3 LN PRE FCA 72H	3149247	3149248	3149249

■ PRE FGR - Two stage progressive/modulating electronic with FGR System, ULTRA Low NOx

See page 240 for more information and codes

OTHER AVAILABLE CONFIGURATIONS

- 60 Hz
- Continuous ventilation (CV)
- Post-purge
- Swirl system for flame geometry customization
- OEM and other special versions on request according to feasibility

i All non-standard configurations are available on request: contact us to know more

OVERALL DIMENSIONS

■ BLU 700.1 ... 1500.3 LN PRE

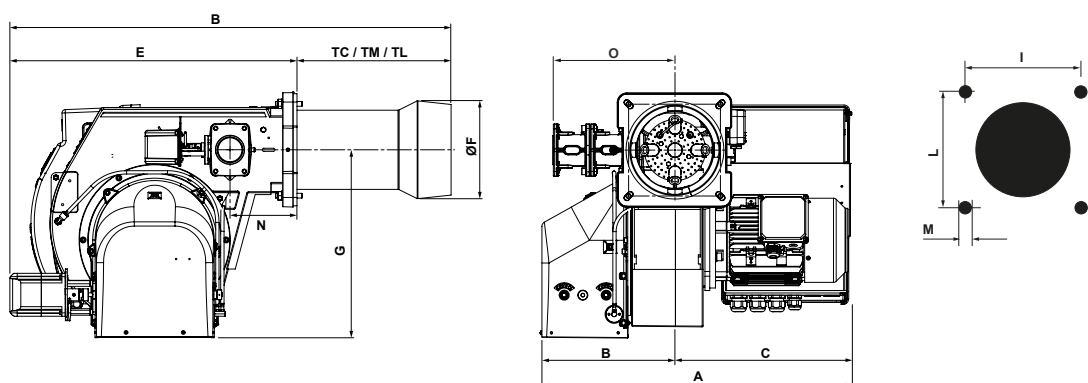

Model	A	B	C	TC	TM	TL	E	ØF	G	I	L	M	N	O
BLU 700.1 LN PRE	663	280	383	174	-	395	543	170	401	185/200	185/200	M10	138	168
BLU 1000.1 LN PRE	663	280	383	174	-	395	543	190	401	185/200	185/200	M10	138	168
BLU 1200.1 LN PRE	663	280	383	309	-	459	543	200	401	185/200	185/200	M10	138	168
BLU 1500.3 LN PRE	643	279	364	345	445	545	602	205	401	185/200	185/200	M10	138	168

■ BLU 2000.3 LN PRE

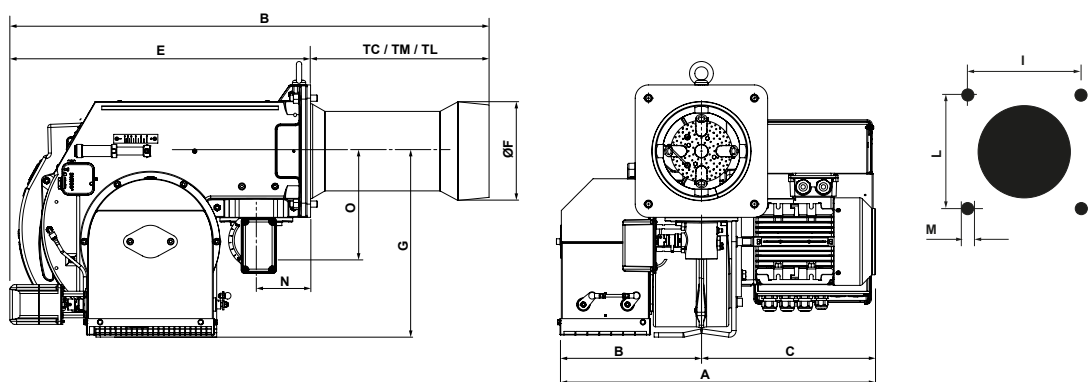

Model	A	B	C	TC	TM	TL	E	ØF	G	I	L	M	N	O
BLU 2000.3 LN PRE	718	321	397	345	445	545	682	224	420	240	240	M14	125	245

■ BLU 2500.3 ... 6000.3 LN PRE

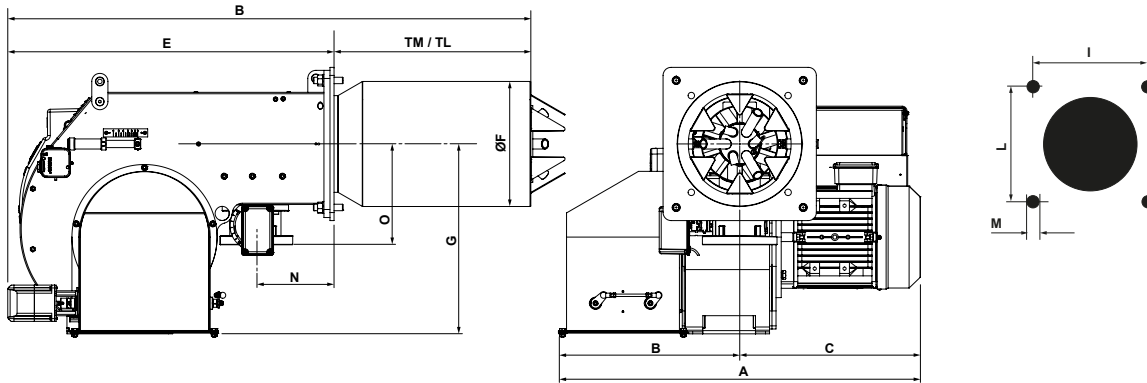

Model	A	B	C	TC	TM	TL	E	F	G	I	L	M	N	O
BLU 2500.3 LN PRE	753	329	424	-	540	640	693	263	420	315	315	M16	133	245
BLU 3000.3 LN PRE	821	351	470	-	550	650	789	263	469	315	315	M16	195	245
BLU 4000.3 LN PRE	898	450	448	-	550	650	809	310	469	315	315	M16	195	250
BLU 5000.3 LN PRE	1122	526	596	-	560	690	930	310	570	330	330	M16	195	250
BLU 6000.3 LN PRE	1122	526	596	-	560	690	930	325	570	330	330	M16	195	250

i Dimensions in mm
Head length: TC short / TL long

PACKAGING

The complete burner with gas train and filter is delivered in a carton box containing boiler fixing accessories and a bag with technical documentation.

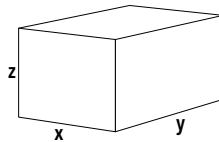

Model	x	y	z	kg
BLU 700.1 LN	800	1070	590	50
BLU 1000.1 LN	800	1070	590	54
BLU 1200.1 LN	800	1070	590	62
BLU 1500.3 LN	800	1070	590	113
BLU 2000.3 LN	930	1300	760	113
BLU 2500.3 LN	930	1300	760	120
BLU 3000.3 LN	1150	1700	930	170
BLU 4000.3 LN	1150	1700	930	180
BLU 5000.3 LN	1590	1590	1080	250
BLU 6000.3 LN	1590	1590	1080	270

Dimensions in mm.

Values referred to burners in standard version; the dimensions of the package may vary according to the configuration chosen

GAS TRAINS

Model	Pressure (mbar) min - max	Model	Size	Codes	Connection pipe	Gas governor and filter
for BLU 700.1 LN	17 - 360	MB-DLE 420	2"	3145934	-	included
	25 - 360	MB-DLE 415	1"1/2	3145933		included
	45 - 360	MB-DLE 412	1"1/4	3145932		included
	75 - 360	MB-DLE 410	1"	3145931		included
for BLU 1000.1 LN	35 - 360	MB-DLE 420	2"	3145934	-	included
	40 - 360	MB-DLE 415	1"1/2	3145933		included
	75 - 360	MB-DLE 412	1"1/4	3145932		included
for BLU 1200.1 LN	20 - 500	VDG 20.503	2"	3145790	-	3121384
	35 - 360	MB-DLE 420	2"	3145934		included
	45 - 360	MB-DLE 415	1"1/2	3145933		included
	85 - 360	MB-DLE 412	1"1/4	3145932		included
for BLU 1500.3 LN	20 - 500	VDG 40.065	DN65	3145793	3147159	3124111
	45 - 500	VDG 20.5011	2"	3145790	-	3121384
for BLU 2000.3 LN	23 - 500	VDG 40.080	DN80	3145814	3148772	3142088
	35 - 500	VDG 40.065	DN65	3145793	3148771	3124111
	60 - 500	VDG 20.5011	2"	3147672	3144686	3121384
for BLU 2500.3 LN	40 - 500	VDG 40.080	DN80	3145814	3148772	3142088
	48 - 500	VDG 40.065	DN65	3145793	3148771	3124111
	82 - 500	VDG 20.5011	2"	3147672	3149594	3121384
for BLU 3000.3 LN	22 - 500	VDG 40.100	DN100	3145817	3148773	3142205
	35 - 500	VDG 40.080	DN80	3145814	3148772	3142088
	55 - 500	VDG 40.065	DN65	3145793	3148771	3124111
	100 - 500	VDG 20.5011	2"	3147672	3149594	3121384
for BLU 4000.3 LN	30 - 500	VDG 40.100	DN100	3145817	3148768	3142205
	50 - 500	VDG 40.080	DN80	3145814	3148767	3142088
	90 - 500	VDG 40.065	DN65	3145793	3148766	3124111
	170 - 500	VDG 20.5011	2"	3147672	3148770	3121384
for BLU 5000.3 LN	35 - 500	VDG 40.125	DN125	3145823	3148769	3142206
	45 - 500	VDG 40.100	DN100	3145817	3148768	3142205
	75 - 500	VDG 40.080	DN80	3145814	3148767	3142088
	140 - 500	VDG 40.065	DN65	3145793	3148766	3124111
	250 - 500	VDG 20.5011	2"	3147672	3148770	3121384
for BLU 6000.3 LN	50 - 500	VDG 40.125	DN125	3145823	3148769	3142206
	60 - 500	VDG 40.100	DN100	3145817	3148768	3142205
	100 - 500	VDG 40.080	DN80	3145814	3148767	3142088
	180 - 500	VDG 40.065	DN65	3145793	3148766	3124111
	340 - 500	VDG 20.5011	2"	3147672	3148770	3121384

! For minimum inlet pressures higher than 250 mbar, choose the pressure switch GW500 (to be fitted during installation on site)
A tightness control device is included (For gas trains in EN676 Configuration it is mandatory over 1200 kW)

GAS TRAINS - DIMENSIONS

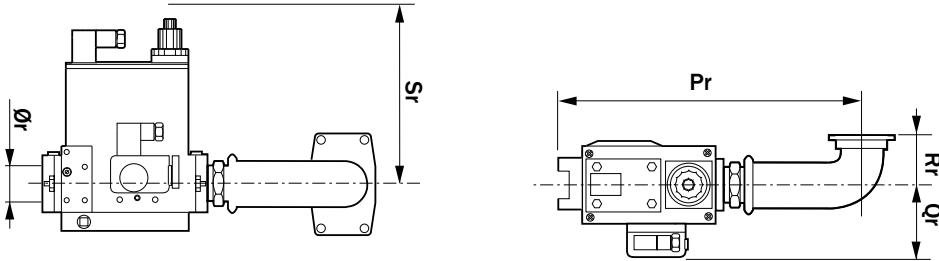

Code	Gas train	Ø	Dimensions (mm)				
			Pr	Qr	Rr	Sr	Ør
3145931	GT-D1-MBDLE410-RP25-PS2	Rp1"	330	102	85	160	1"
3145932	GT-D1-MBDLE412-RP32-PS2	Rp1"1/4	330	102	85	160	1"1/4
3145933	GT-D1-MBDLE415-RP25-PS2	Rp1"1/2	410	90	85	175	1"1/2
3145934	GT-D1-MBDLE420-RP32-PS2	Rp2"	420	90	85	175	2"

TOTAL DIMENSIONS CALCULATION

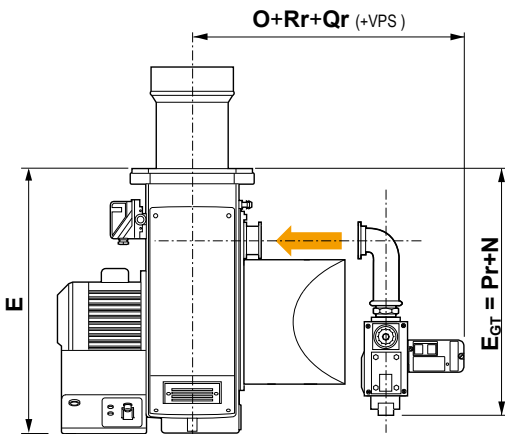

i To calculate the overall dimensions, consider the greater value between E and E_{GT}

GAS TRAINS - DIMENSIONS

■ VGD 20...

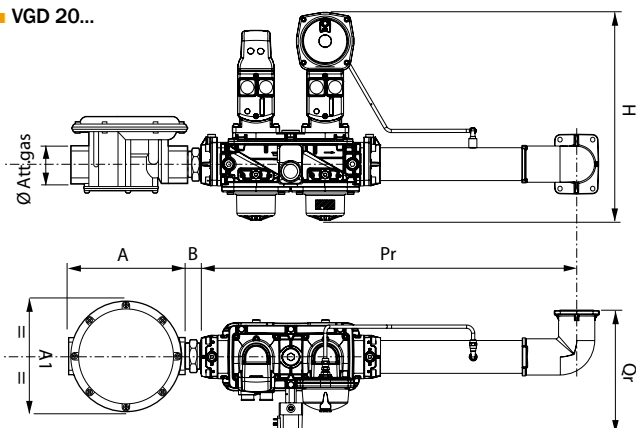

■ VGD 40...

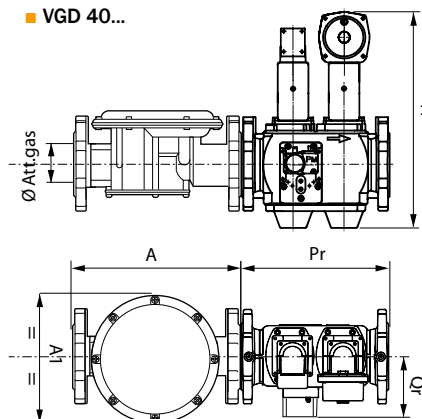

Code	Gas train	Ø	Dimensions (mm)			
			Pr	Qr	H	B
3145790	GT-S1-VGD20-RP50-PS2	Rp2"	689	226	382	36
3145793	GT-S1-VGD40-DN65-PS2	DN65	290	127,3	421	-
3145814	GT-S1-VGD40-DN80-PS2	DN80	310	127,3	445	-
3145817	GT-S1-VGD40-DN100-PS2	DN100	350	145,4	476	-
3145823	GT-S1-VGD40-DN125-PS2	DN125	400	158,4	524	-

■ VGD 20... PS2-S

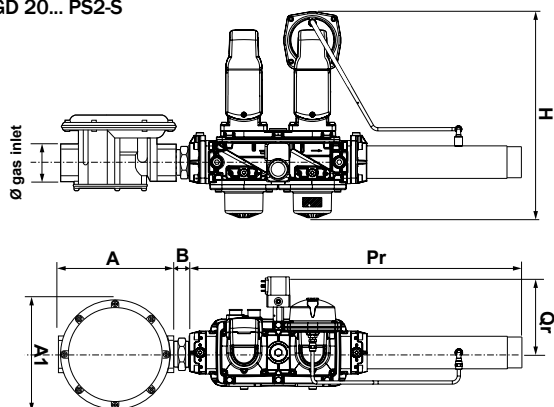

Code	Model	Ø	Dimensions (mm)			
			Pr	Qr	H	B
3147672	GT-S1-VGD20-RP50-PS2-S	Rp2"	628	34,9	382	36

GAS TRAINS - DIMENSIONS

CONNECTION PIPE

Code	Pic.	Dimensions (mm)		
		T	U	V
4396173	1	85	580	-
3144686	3	100	32	-
3147159	4	-	500	-
3148766	2	122	778	145
3148767	2	145	778	120
3148768	2	145	778	120
3148769	2	145	788	157
3148771	5	100	602	106
3148772	5	100	602	125
3148773	5	100	602	125
3149594	7	100	507	-

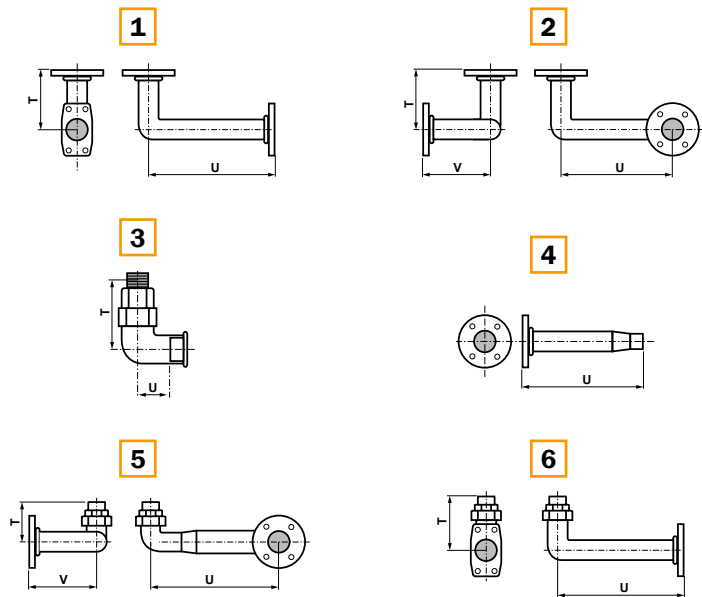

GAS FILTER

Code	Ø	Dimensions (mm)		
		A	A1	B
3121384	Rp2"	186	186	>100
3124111	DN65	290	212	-
3142088	DN80	320	240	-
3142205	DN100	380	280	-
3142206	DN125	380	280	-

GAS TRAINS - DIMENSIONS

TOTAL DIMENSIONS CALCULATION

BLU 700.1 ... 1200.1

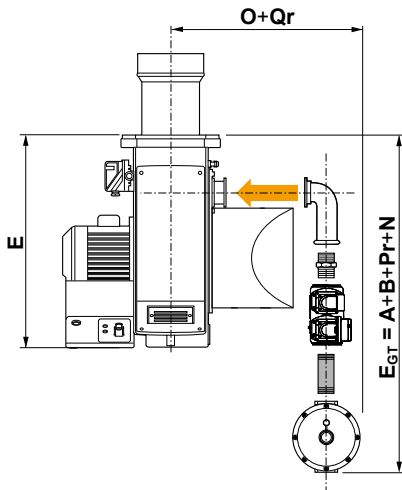

BLU 1500.3

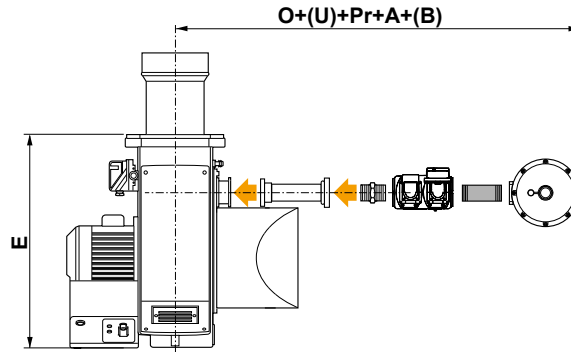

BLU 2000.3 ... 6000.3

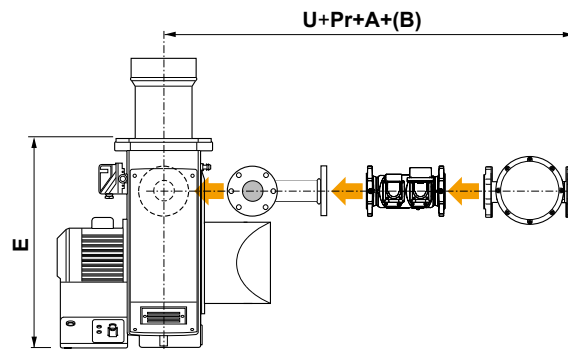
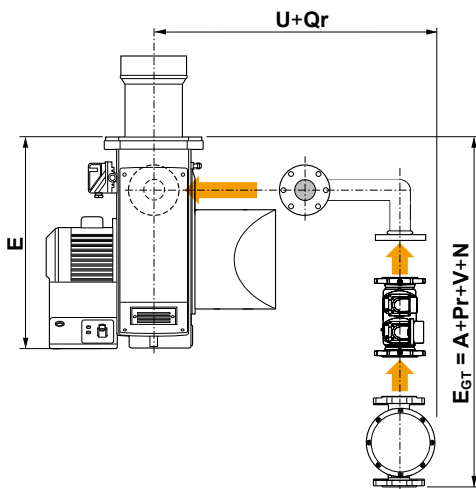

To calculate the overall dimensions, consider the greater value between E and E_{GT}

OPTIONS**MODULATING
PID CONTROLLER**

Description	Code
Kit RWF50 for BLU 700.1 ... 1200.1	3143713
Kit RWF50 for BLU 1500.3 ... 6000.3	3147786
Kit RWF55 for BLU 700.1 ... 1200.1	3143714
Kit RWF55 for BLU 1500.3 ... 6000.3	3147787

i Kit supplied loose; on-board assembly available upon request
See page 257 for more information on RWF kit features

**TEMPERATURE AND
PRESSURE PROBES**

Description	Code
Water probe, temperature range from 0 to 130 °C	3122316
Steam probe 0 ... 2 bar	3124100
Steam probe 0 ... 4 bar	3122317
Steam probe 0 ... 10 bar	3122318
Steam probe 0 ... 16 bar	3122319
Steam probe 0 ... 25 bar	3834314
Steam probe 0 ... 40 bar	3122320
Probe for external temperature from -35 ° to 50 °C	3122315
Hot air or liquid probe, temperature range from -50 ° to 400 °C	3122314
Thermocouple J type, temperature up to 750 °C (for RWF55 only)	3146725

**FREQUENCY
CONVERTER**

Description	Code	
IP21 with: • EMC filter • Inductor • Control panel	3 kW	3757054
	4 kW	3757055
	5,5 kW	3757056
	7,5 kW	3757057
	11 kW	3757058
	15 kW	3757059
IP55 with: • EMC filter • Inductor • Control panel	3 kW	3757067
	4 kW	3757068
	5,5 kW	3757069
	7,5 kW	3757070
	11 kW	3757071
	15 kW	3757072

KIT LPG

Description	Models	Code
LPG conversion kit for gas burners	BLU 700.1 LN / 1000.1 LN / 1200.1 LN	3144610
	BLU 1500.3 LN	3149576
	BLU 2000.3 LN	3149577
	BLU 2500.3 LN / 3000.3 LN	3149288
	BLU 4000.3 LN	3149289
	BLU 5000.3 LN / 6000.3 LN	3149290

OPTIONS**MAXIMUM GAS PRESSURE SWITCH**

Description	Output range	Setting range	Code
Kit GPS 150	<15 MW	5 ... 150 mbar	3147771

GAS GOVERNOR WITH BUILT-IN FILTER

! Default spring is neutral for outlet pressure range 10 - 30 mbar

Size	Maximum gas pressure	Code
Rp1"	500 mbar	3142521
Rp1"1/4	500 mbar	3142522
Rp1"1/2	500 mbar	3142523
Rp2"	500 mbar	3142524
Rp2"	1 bar	3142051
DN65	1 bar	3141983
DN80	1 bar	3142538
DN100	1 bar	on request
DN125	1 bar	on request

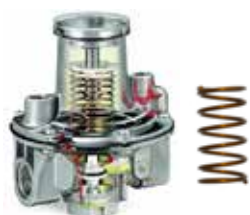
SPRINGS FOR GAS GOVERNOR

Description	Sizes	Gas pressure range	Code
Green spring	1/2", 3/4", 1"	5 ... 15 mbar	3142547
Neutral spring		10 ... 30 mbar	3142548
Violet spring		25 ... 80 mbar	3142549
Brown spring		70 ... 160 mbar	3142550
Blue spring		150 ... 280 mbar	3142551
White spring		270 ... 350 mbar	3142552
Green spring	1"1/4, 1"1/2	5 ... 15 mbar	3142553
Neutral spring		10 ... 30 mbar	3142554
Violet spring		20 ... 70 mbar	3142555
Brown spring		65 ... 130 mbar	3142556
White spring		120 ... 250 mbar	3142557
Black spring		240 ... 350 mbar	3142558
Green spring	2"	5 ... 15 mbar	3142559
Neutral spring		10 ... 30 mbar	3142560
Violet spring		30 ... 80 mbar	3142561
Brown spring		70 ... 220 mbar	3142562
Blue spring		210 ... 350 mbar	3142563
Red spring		25-80 mbar	3144252
Violet spring	DN65, DN80	60-120 mbar	3144253
Blue spring		100-220 mbar	3144254
White spring		200-450 mbar	3144255
Red spring	DN100	30-70 mbar	3144256
Violet spring		60-110 mbar	3144257
Brown spring		100-210 mbar	3144258
White spring		200-450 mbar	3144060

OPTIONS

GAS FILTER



Size	Code
Rp1"	3142046
Rp1"1/2	3141954
Rp2"	3121384
DN65	3124111
DN80	3142088
DN100	3142205
DN125	3142206

ANTIVIBRATION JOINT



Size	Code
Rp1"	3122323
Rp1"1/4	3122324
Rp1"1/2	3122325
Rp2"	3122326
DN65	3142060
DN80	3122328
DN100	3122329
DN125	3142061

MANUAL VALVE



Size	Code
Rp1"	3121430
Rp1"1/4	3142253
Rp1"1/2	3142101
Rp2"	3142102
DN65	3142062
DN80	3143730
DN100	3141997
DN125	3141998

MANOMETER + PUSH BUTTON



Description	Pressure range	Code
Gas manometer 1/2"	0...60 mbar	3142056
Gas manometer 1/4"	0...250 mbar	3142055
Gas manometer 1/4"	0...1000 mbar	3142054
Push button 1/2"		3142057
Push button 1/4"		3142058

FREQUENCY CONVERTER ARRANGEMENT

Description	Code
Models BLU .1 prepared to be connected to an external frequency converter	on request

i This variant includes the VSM module to control the frequency converter; a LCM module is required and must be added separately

OPTIONS

LCM MODULE

Description	Code
LCM module mounted in factory for communication via BUS, O ₂ control and frequency converter	3146795

REMOTE SOFTWARE

Description	Code
Kit to connect a PC to the BT300 for its parametrization (LSA100 + USB/CAN + CD-Rom)	3751130

COMMUNICATION MODULES

Description	Code	
Additional module for BT3 (supplied loose)	ModBus/BT3	on request
	Profibus/BT3	on request
	Ethernet/BT3	on request

O₂ TRIM

Flue temp max 300 °C
 Display for O₂ visualization
 The kit includes:

- Lambda transmitter LT3
- Lambda probe LS2
- Probe installation fitting
- Gas extraction device



! For models equipped with BT3 this kit needs a LCM module installed in the burner control panel

Additional LSB modules installed at LT3	GED length	Code
None	150 mm	3759296
	300 mm	3759297
	450 mm	3759298
4x 0/4-20 mA output	150 mm	3759299
	300 mm	3759300
	450 mm	3759301
4x 0/4-20 mA output + 4x digital output	150 mm	3759302
	300 mm	3759303
	450 mm	3759304

Description	Code	
Extension for LS2	5m ready-made cable	3759318
	PCB (probe connection box) ¹	3759319

O₂ AND CO TRIM

Flue temp max 300 °C
 The kit includes:

- Lambda transmitter LT3-F
- Lambda probe KS1D
- Probe installation fitting
- Gas extraction device

! For models equipped with BT3 this kit needs a LCM module installed in the burner control panel

Additional LSB modules installed at LT3-F	GED length	Code
none	150 mm	3759305
	300 mm	3759306
	450 mm	3759307
4x 0/4-20 mA output	150 mm	3759308
	300 mm	3759309
	450 mm	3759310
4x 0/4-20 mA output + 4x digital output	150 mm	3759311
	300 mm	3759312
	450 mm	3759313

Description	Code	
Extension for KS1D	5m ready-made cable	3759318
	PCB (probe connection box) ¹	3759319

! ¹: The PCB is mandatory if the end user chooses to use his own connecting cable and not one of those proposed above
 See page 260 for further information

- BLU models from 1000.1 to 6000.1 are monoblock force-draught burners working with natural gas or LPG and covering an output range from 245 to 6000 kW
- These models are equipped with low NOx class 2 ($\text{NO}_x \leq 120 \text{ mg/kWh}$) combustion heads according to the EN676 European Standard and are available in two different typess of operation:
 - PAB: two stage operation (up to BLU 2000.1)
 - PR: two stage progressive mechanical or modulating with the installation of a power regulator and dedicated probes
- The BLU .2 series has been designed with a new air/gas control system: the servomotor operates directly on the butterfly gas valve and the air damper is controlled through a mechanical leverage connected to the cam; this system allows a more precise regulation of the air damper following the gas valve setting made through the servomotor
- Electronic versions are also available: see page 102
- As all the Ecoflam burners they are equipped with an adjustable combustion head for easy regulation and matching with different combustion chambers
- The structure of the burners allow easy access to the internal components for fast start-up and reduced maintenance time and space
- Multiple gas train matching are available according to the inlet gas pressure



WORKING DIAGRAM

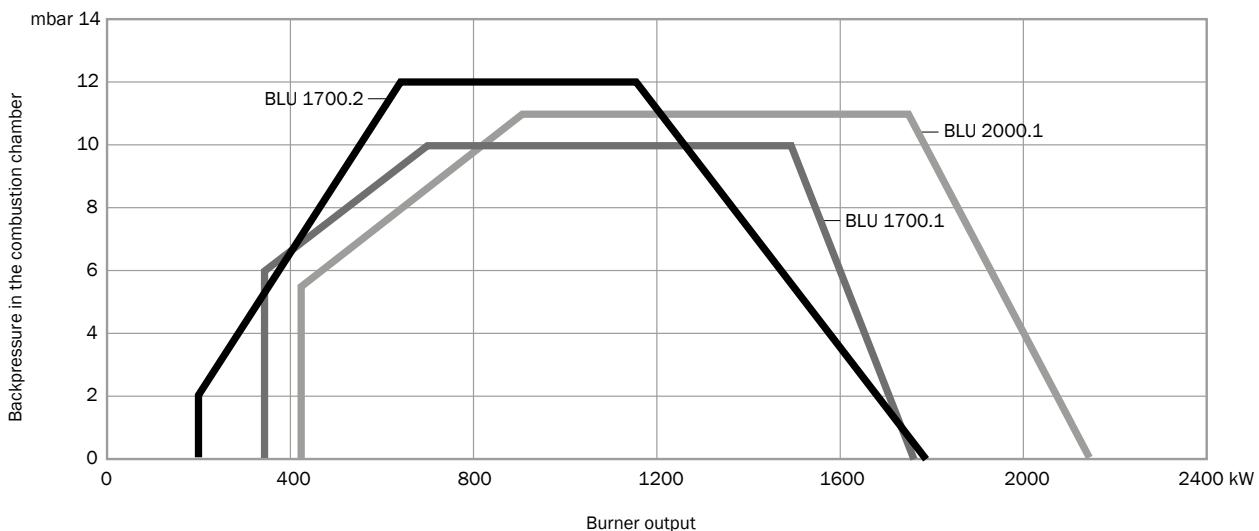
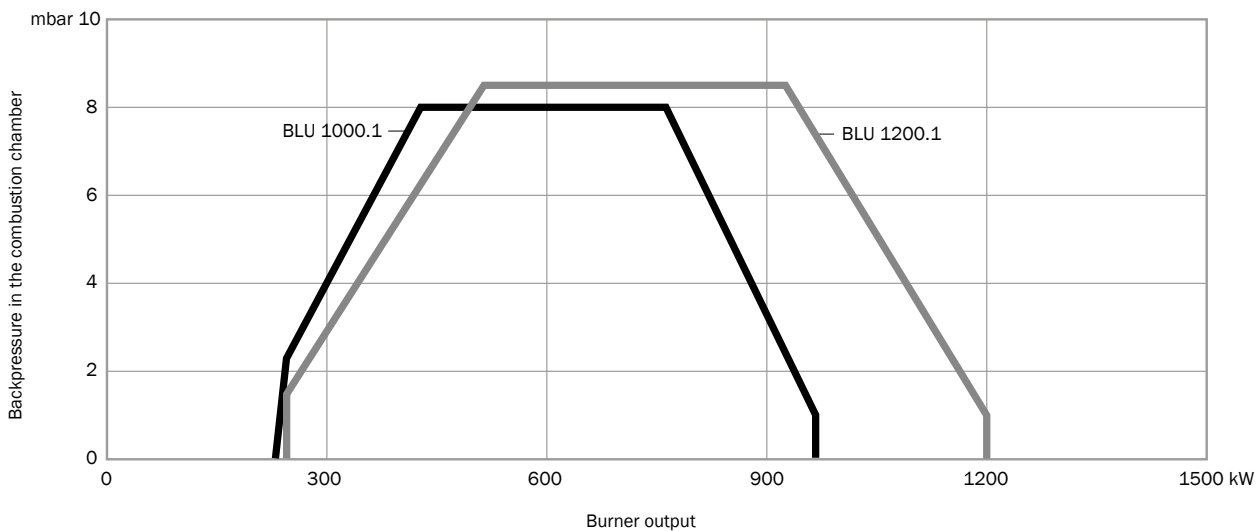

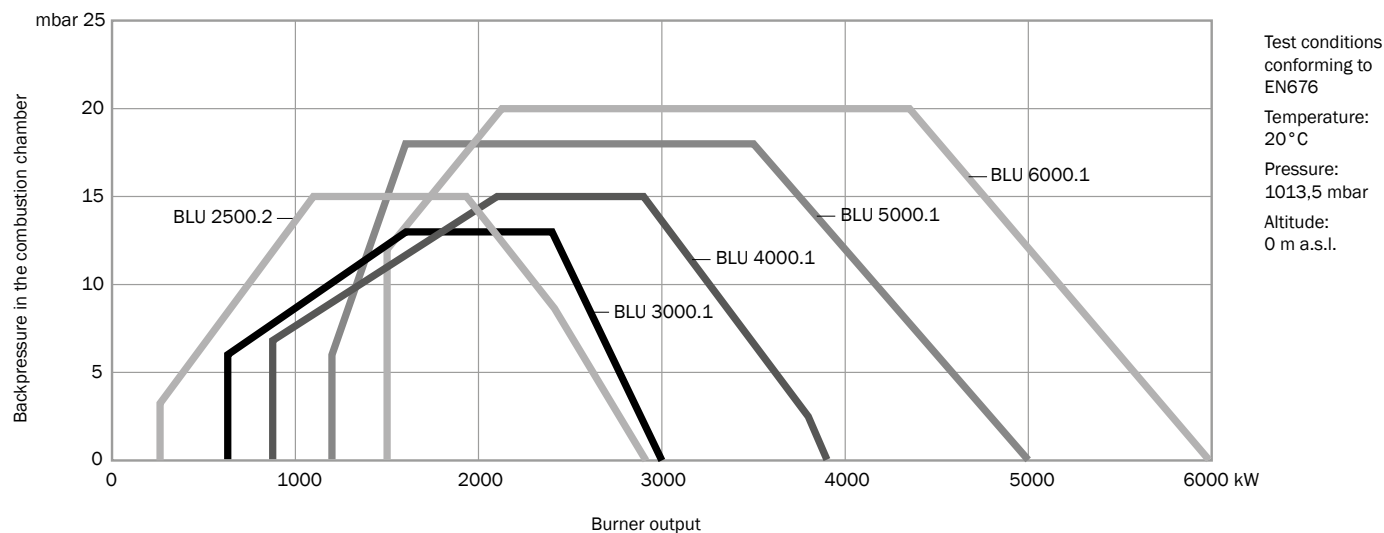

TECHNICAL DATA

Model	Operation	Output (kW)	Control box	Flame detector	Power supply	Motor (kW)	Emissions
BLU 1000.1	PAB PR	245 - 970	LME22	Ionization	3/230-400/50Hz	1,1	Class 2
BLU 1200.1	PAB PR	260 - 1200	LME22	Ionization	3/230-400/50Hz	2,2	Class 2
BLU 1700.1	PAB PR	342 - 1770	LME22	Ionization	3/230-400/50Hz	3	Class 2
BLU 1700.2	PAB PR	200 - 1780	LME22	Ionization	3/230-400/50Hz	2,2	Class 2
BLU 2000.1	PAB PR	414 - 2150	LME22	Ionization	3/400/50Hz	4	Class 2
BLU 2500.2	PR	290 - 2950	LME22	Ionization	3/400/50Hz	4	Class 2
BLU 3000.1	PR	630 - 3000	LME73	Ionization	3/400/50Hz	5,5	Class 2
BLU 4000.1	PR	875 - 3900	LME73	Ionization	3/400/50Hz	7,5	Class 2
BLU 5000.1	PR	1200 - 5000	LME73	Ionization	3/400/50Hz	11	Class 2
BLU 6000.1	PR	1500 - 6000	LME73	Ionization	3/400/50Hz	15	Class 2

CODES

■ PAB - Two stages

Model	TC	TL
BLU 1000.1 PAB	3144040	3144041
BLU 1200.1 PAB	3144043	3144044
BLU 1700.1 PAB	3140326	3140327
BLU 1700.2 PAB	3148271	3148272
BLU 2000.1 PAB	3140330	3140331

■ PR - Two stage progressive/modulating mechanical

Model	TC	TL
BLU 1000.1 PR	3144045	3144046
BLU 1200.1 PR	3144047	3144048
BLU 1700.1 PR	3140401	3140402
BLU 1700.2 PR	3147091	3147094
BLU 2000.1 PR	3140403	3140404
BLU 2500.2 PR	3147093	3147096
BLU 3000.1 PR	3145867	3145868
BLU 4000.1 PR	3145869	3145870
BLU 5000.1 PR	3145871	3145872
BLU 6000.1 PR	3145873	3145874

OTHER AVAILABLE CONFIGURATIONS

- 60 Hz
- Continuous ventilation (CV)
- Post-purge
- LPG version (starting from BLU 1700.1)
- Swirl system for flame geometry customization
- OEM and other special versions on request according to feasibility



All non-standard configurations are available on request: contact us to know more

OVERALL DIMENSIONS

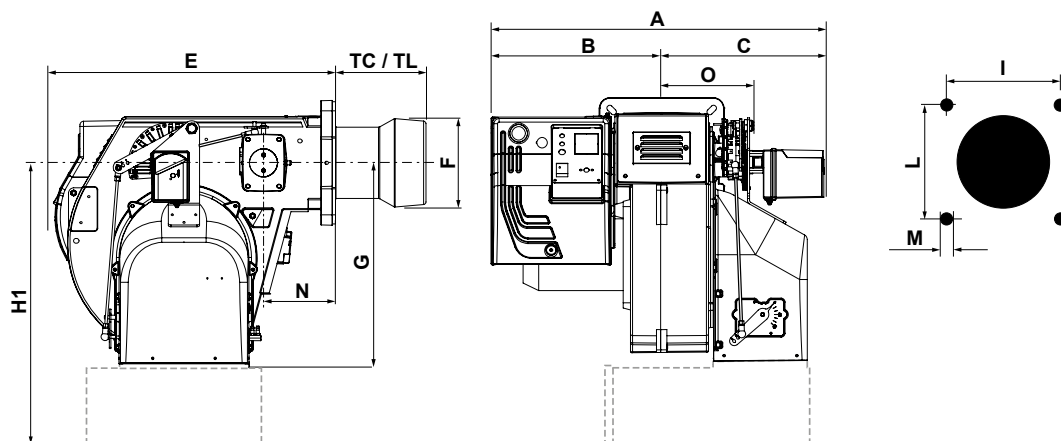

Model	A	B	C	TC	TL	E	F	G	H1 ¹	I	L	M	N	O
BLU 1000.1 PAB	608	328	280	174	394	543	190	104	601	185/200	185/200	M10	138	168
BLU 1200.1 PAB	608	328	280	309	459	543	200	401	601	185/200	185/200	M10	138	168
BLU 1700.2 PAB	642	328	314	348	500	543	225	401	601	185/200	185/200	M10	138	168
BLU 1000.1 PR	657	328	329	174	394	543	190	401	601	185/200	185/200	M10	138	420
BLU 1200.1 PR	657	328	329	309	459	543	200	401	601	185/200	185/200	M10	138	420
BLU 1700.2 PR	642	328	314	348	500	543	225	401	601	185/200	185/200	M10	138	168

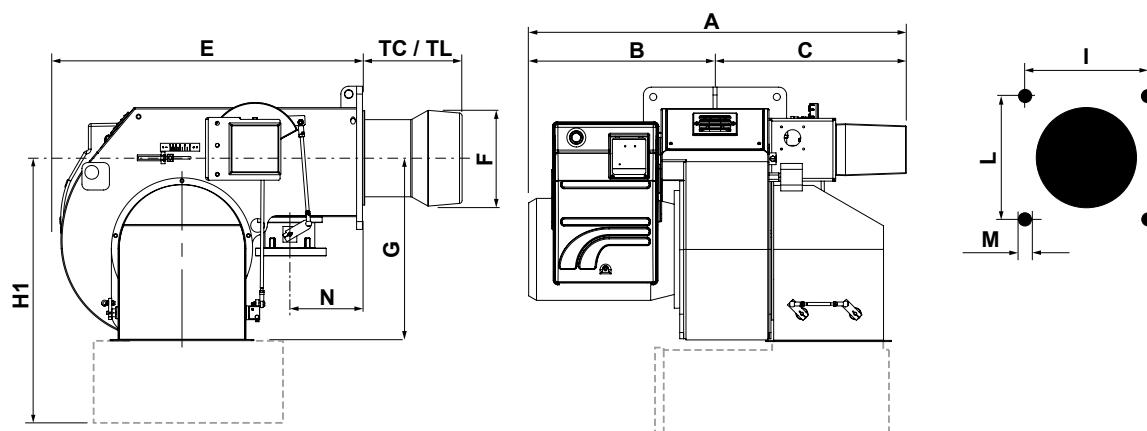

Model	A	B	C	TC	TL	E	F	G	H1 ¹	I	L	M	N	O
BLU 1700.1 PAB	710	385	325	340	540	680	250	420	680	240	240	M14	125	250
BLU 2000.1 PAB	730	405	325	345	545	680	270	420	680	240	240	M14	125	250
BLU 1700.1 PR	712	364	348	340	540	730	250	420	680	240	240	M14	125	250
BLU 2000.1 PR	712	364	348	345	545	730	270	420	680	240	240	M14	125	250
BLU 2500.2 PR	775	424	351	380	580	657	300	420	680	315	315	M16	133	245
BLU 3000.1 PR	941	448	493	330	530	780	290	471	746	315	315	M16	195	250
BLU 4000.1 PR	941	448	493	365	565	780	320	471	746	315	315	M16	195	250
BLU 5000.1 PR	1019	495	524	375	575	970	320	570	965	330	330	M16	195	250
BLU 6000.1 PR	1069	545	524	375	575	970	360	570	965	330	330	M16	195	250

i Dimensions in mm
 Head length: TC short / TL long
¹: with silencer (optional)

PACKAGING

The complete burner with gas train and filter is delivered in a carton box containing boiler fixing accessories and a bag with technical documentation.

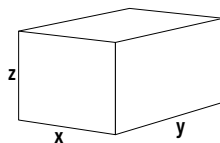

Model	x	y	z	kg
BLU 1000.1	800	1070	590	50
BLU 1200.1	800	1200	590	59
BLU 1700.1	930	1300	760	101
BLU 1700.2	800	1200	590	67
BLU 2000.1	930	1300	760	118
BLU 2500.2	930	1300	760	129
BLU 3000.1	1150	1380	960	228
BLU 4000.1	1150	1700	930	242
BLU 5000.1	1590	1590	1080	350
BLU 6000.1	1590	1590	1080	372

Dimensions in **mm**.

Values referred to burners in standard version; the dimensions of the package may vary according to the configuration chosen

GAS TRAINS

Model	Pressure (mbar) min - max	Model	Size	Codes	Connection pipe	Gas governor and filter
for BLU 1000.1	27 - 360	MB-DLE 420	2"	3141847	-	included
	35 - 360	MB-DLE 415	1"1/2	3141846		included
	75 - 360	MB-DLE 412	1"1/4	3141845		included
for BLU 1200.1	25 - 500	VGD 20.503	2"	3123860	-	3121384
	40 - 360	MB-DLE 420	2"	3141847		included
	50 - 360	MB-DLE 415	1"1/2	3141846		included
	100 - 360	MB-DLE 412	1"1/4	3141845		included
for BLU 1700.1	20 - 500	VGD 40.080	DN80	3142026	3142069	3142088
	45 - 500	VGD 20.503	2"	3123860	4396172	3121384
	60 - 360	MB-DLE 420	2"	3141847	4396172	included
	85 - 360	MB-DLE 415	1"1/2	3141846	4396172	included
for BLU 1700.2	20 - 360	VGD 40.080	DN80	3147132	3147160	3142088
	35 - 500	VGD 40.065	DN65	3147131	3147159	3124111
	45 - 500	VGD 20.5011	2"	3147130	-	3121384
	60 - 360	MB-DLE 420	2"	3144925	-	included
	85 - 360	MB-DLE 415	1"1/2	3144924	-	included
for BLU 2000.1	23 - 500	VGD 40.080	DN80	3142026	3145815	3142088
	35 - 500	VGD 40.065	DN65	3124110	3145800	3124111
	60 - 500	VGD 20.503	2"	3123860	4396172	3121384
	75 - 360	MB-DLE 420	2"	3141847	4396172	included
	100 - 360	MB-DLE 415	1"1/2	3141846	4396172	included
for BLU 2500.2	35 - 500	VGD 40.080	DN80	3147132	3144686 + 3147160	3142088
	55 - 500	VGD 40.065	DN65	3147131	3144686 + 3147159	3124111
	100 - 500	VGD 20.5011	2"	3147130	3144686	3121384
for BLU 3000.1	22 - 500	VGD 40.100	DN100	3146007	3145820	3142205
	35 - 500	VGD 40.080	DN80	3146006	3145815	3142088
	55 - 500	VGD 40.065	DN65	3146005	3145800	3124111
	100 - 500	VGD 20.503	2"	3146004	4396173	3121384
for BLU 4000.1	30 - 500	VGD 40.100	DN100	3146007	3145820	3142205
	50 - 500	VGD 40.080	DN80	3146006	3145815	3142088
	90 - 500	VGD 40.065	DN65	3146005	3145800	3124111
	170 - 500	VGD 20.503	2"	3146004	4396173	3121384
for BLU 5000.1	35 - 500	VGD 40.125	DN125	3146008	3145830	3142206
	45 - 500	VGD 40.100	DN100	3146007	3145821	3142205
	75 - 500	VGD 40.080	DN80	3146006	3145864	3142088
	140 - 500	VGD 40.065	DN65	3146005	3145997	3124111
	250 - 500	VGD 20.503	2"	3146004	4396173	3121384
for BLU 6000.1	50 - 500	VGD 40.125	DN125	3146008	3145830	3142206
	60 - 500	VGD 40.100	DN100	3146007	3145821	3142205
	100 - 500	VGD 40.080	DN80	3146006	3145864	3142088
	180 - 500	VGD 40.065	DN65	3146005	3145997	3124111
	340 - 500	VGD 20.503	2"	3146004	4396173	3121384

! Default blank spring: head pressure 0...22 mbar; choose and change spring and damping (to be fitted during installation on site)
 For minimum inlet pressures higher than 250 mbar, choose the pressure switch GW500 (to be fitted during installation on site)
 For gas trains in EN676 Configuration a tightness control device must be included over 1200 kW

GAS TRAINS - DIMENSIONS

1

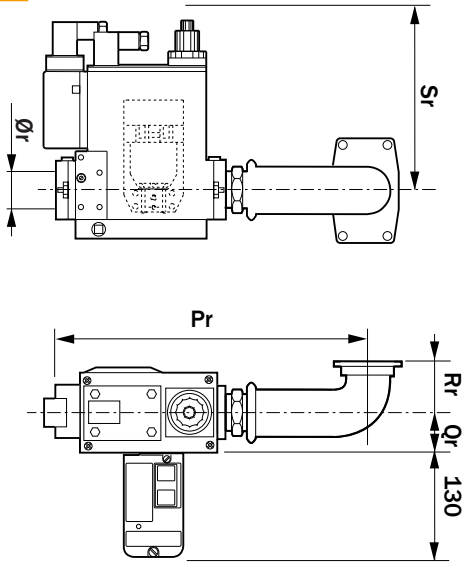

2

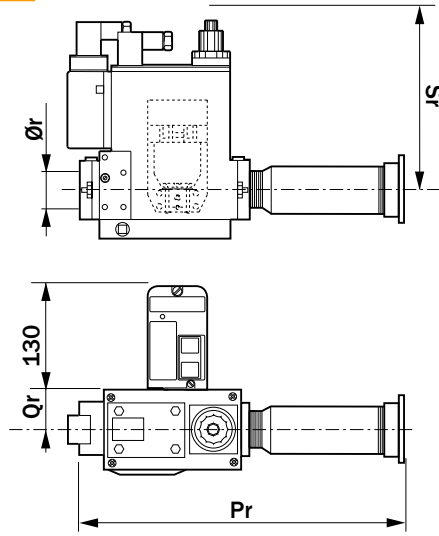

Code	Gas train	\varnothing	Pic.	Dimensions (mm)				
				Pr	Qr	Rr	Sr	$\varnothing r$
3141845	GT-D1-MBDLE412-RP32-BLU/MULTI	Rp1"1/4	1	330	62	85	160	1"1/4
3141846	GT-D1-MBDLE415-RP40-BLU/MULTI	Rp1"1/2	1	410	50	85	175	1"1/2
3141847	GT-D1-MBDLE420-RP50-BLU/MULTI	Rp2"	1	420	50	85	175	2"
3144924	GT-D1-MBDLE415-RP40-PS1	Rp1"1/2	2	592	50	-	169	1"1/2
3144925	GT-D1-MBDLE420-RP50-PS1	Rp2"	2	594	50	-	217	2"

CONNECTION PIPE

Code	Dimensions (mm)	
	T	U
4396172	85	450

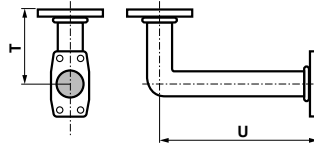

TOTAL DIMENSIONS CALCULATION

BLU 1000.1 / 1200.1

BLU 1700.1 ... 2000.1

BLU 1700.2

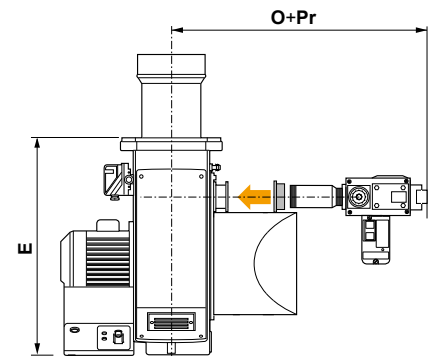
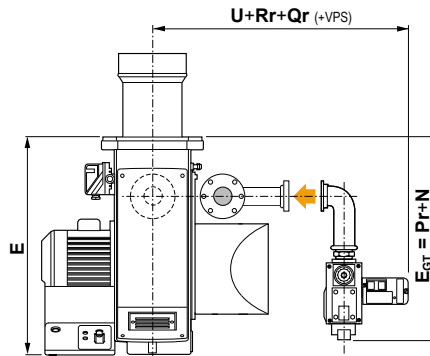
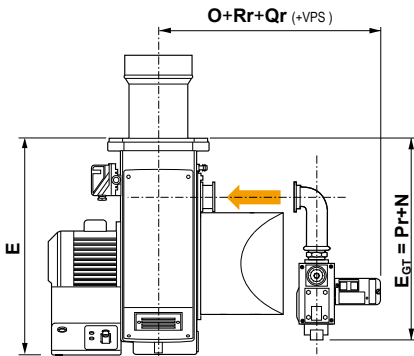

i To calculate the overall dimensions, consider the greater value between E and E_{GT}

GAS TRAINS - DIMENSIONS

■ VGD 20...

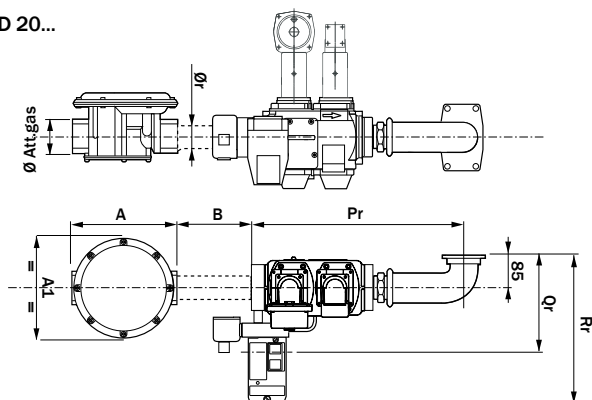

■ VGD 40...

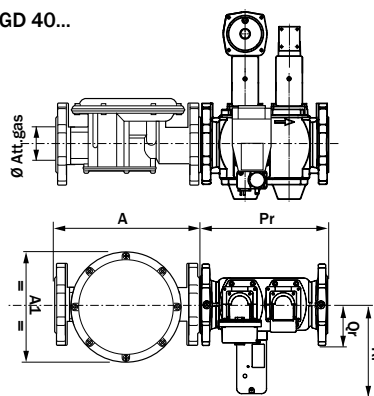

Code	Gas train	Ø	Dimensions (mm)			
			Pr	Qr	Rr	Ør
3123860	GT-S1-VGD20-RP50-BLU/MULTI	Rp2"	450	185	315	2"
3124110	GT-S1-VGD40-DN65-BLU/MULTI	DN65	290	97	211	DN65
3142026	GT-S1-VGD40-DN80-BLU/MULTI	DN80	310	102	218	DN80

■ VGD 20... PS1-S

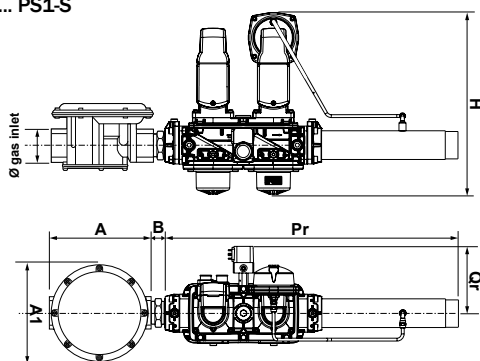

■ VGD 40... PS1-S

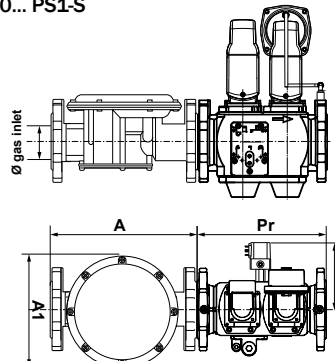

■ VGD 20... PS3

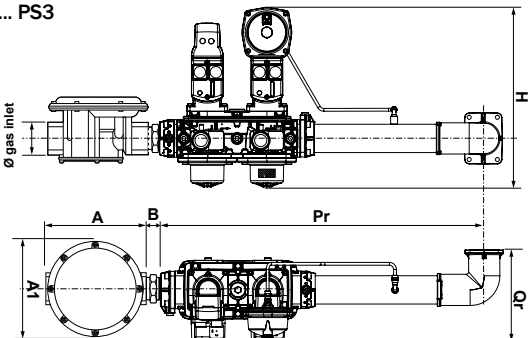

■ VGD 40... PS3

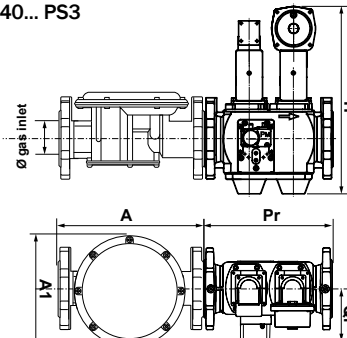

Code	Gas train	Ø	Dimensions (mm)			
			Pr	Qr	H	B
3146004	GT-S1-VGD20-RP50-PS3	Rp2"	689	193	382	36
3146005	GT-S1-VGD40-DN65-PS3	DN65	290	127,3	421	-
3146006	GT-S1-VGD40-DN80-PS3	DN80	310	127,3	445	-
3146007	GT-S1-VGD40-DN100-PS3	DN100	350	145,4	476	-
3146008	GT-S1-VGD40-DN125-PS3	DN125	400	158,4	524	-
3147130	GT-S1-VGD20-RP50-PS1-S	Rp2"	689	34,9	382	36
3147131	GT-S1-VGD40-DN65-PS1-S	DN65	290	125,8	421	-
3147132	GT-S1-VGD40-DN80-PS1-S	DN80	310	127,3	445	-

GAS TRAINS - DIMENSIONS

CONNECTION PIPE

Code	Pic.	Dimensions (mm)		
		T	U	V
3142069	2	125	560	125
4396172	1	85	450	-
4396173	1	85	580	-
3144686	3	100	32	-
3145800	2	101	560	101
3145815	2	122	560	122
3145820	2	248	560	122
3145821	2	122	668	122
3145830	2	156	718	122
3145864	2	122	668	122
3145997	2	122	668	122
3147159	4	-	500	-
3147160	5	-	500	-

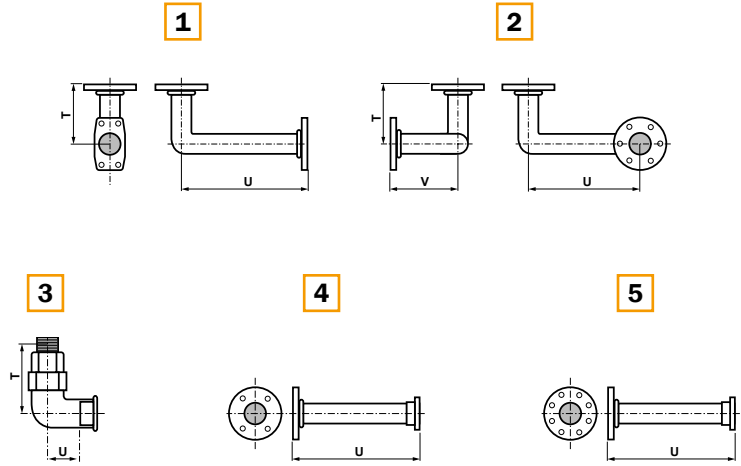

GAS FILTER

Code	Ø	Dimensions (mm)		
		A	A1	B
3121384	Rp2"	186	186	>100
3124111	DN65	290	212	-
3142088	DN80	320	240	-
3142205	DN100	380	280	-
3142206	DN125	380	280	-

TOTAL DIMENSIONS CALCULATION

BLU 1000.1 / 1200.1

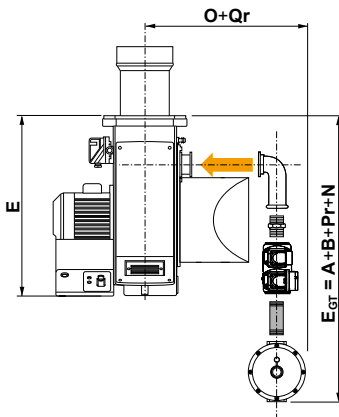

BLU 1700.1 ... 6000.1

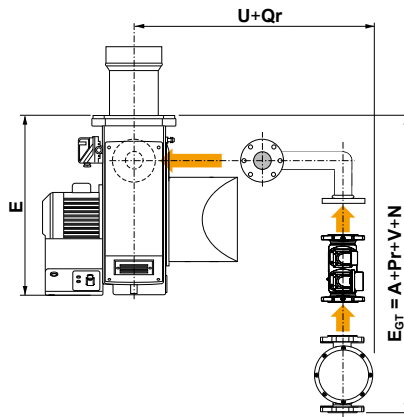

BLU 1700.2

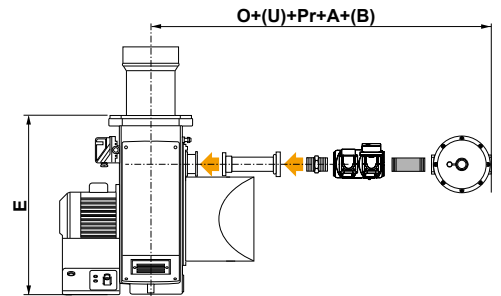

i To calculate the overall dimensions, consider the greater value between E and E_{Gr}

OPTIONS

MODULATING PID CONTROLLER



Description	Code
Kit RWF50	3143713
Kit RWF55 for BLU 1000.1 ... 2500.2	3143714
Kit RWF55 for BLU 3000.1 ... 6000.1	3147787

i Kit supplied loose; on-board assembly available upon request
 See page 257 for more information on RWF kit features

TEMPERATURE AND PRESSURE PROBES



Description	Code
Water probe, temperature range from 0 to 130 °C	3122316
Steam probe 0 ... 2 bar	3124100
Steam probe 0 ... 4 bar	3122317
Steam probe 0 ... 10 bar	3122318
Steam probe 0 ... 16 bar	3122319
Steam probe 0 ... 25 bar	3834314
Steam probe 0 ... 40 bar	3122320
Probe for external temperature from -35° to 50 °C	3122315
Hot air or liquid probe, temperature range from -50° to 400 °C	3122314
Thermocouple J type, temperature up to 750 °C (for RWF55 only)	3146725

CUSTOMER INTERFACE KIT DISPLAY

Description	Code
Kit display AZL21 for burners equipped with Siemens LME7	3148779

FREQUENCY CONVERTER



Description	Code		
IP21 with:	3 kW	3757054	
	4 kW	3757055	
	• EMC filter	5,5 kW	3757056
	• Inductor	7,5 kW	3757057
	• Control panel	11 kW	3757058
		15 kW	3757059
IP55 with:	3 kW	3757067	
	4 kW	3757068	
	• EMC filter	5,5 kW	3757069
	• Inductor	7,5 kW	3757070
	• Control panel	11 kW	3757071
		15 kW	3757072

TIGHTNESS CONTROL

! For gas trains in EN676 Configuration a tightness control device must be included over 1200 kW

Description	Code
Kit VPS504 for MB-DLE/MB-ZRDLE and VGD DN65/80/100 valves, working with natural gas	3122303
Kit VPS504 for MB-DLE/MB-ZRDLE and VGD DN65/80/100 valves, working with LPG	3142190
Kit VPS504 for VGD20.503 valve, working with natural gas	3122305
Kit VPS504 for VGD20.503 valve, working with LPG	3142688
Kit VDK for VGD valve, DN125 size	3141922
Kit LDU	3142314
Adapter for VPS pilot gas train	3142754

OPTIONS

MAXIMUM GAS PRESSURE SWITCH

Description	Output range	Setting range	Code
Kit GPS 50	<6 MW	5 ... 50 mbar	3141921

GAS GOVERNOR WITH BUILT-IN FILTER

! Default spring is neutral for outlet pressure range 10 - 30 mbar

Size	Maximum gas pressure	Code
Rp1"1/4	500 mbar	3142522
Rp1"1/2	500 mbar	3142523
Rp2"	500 mbar	3142524
Rp2"	1 bar	3142051
DN65	1 bar	3141983
DN80	1 bar	3142538
DN100	1 bar	on request
DN125	1 bar	on request

SPRINGS FOR GAS GOVERNOR

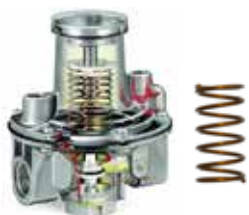

Description	Size	Gas pressure range	Code
Green spring	1"1/4, 1"1/2	5 ... 15 mbar	3142553
Neutral spring		10 ... 30 mbar	3142554
Violet spring		20 ... 70 mbar	3142555
Brown spring		65 ... 130 mbar	3142556
White spring		120 ... 250 mbar	3142557
Black spring		240 ... 350 mbar	3142558
Green spring	2"	5 ... 15 mbar	3142559
Neutral spring		10 ... 30 mbar	3142560
Violet spring		30 ... 80 mbar	3142561
Brown spring		70 ... 220 mbar	3142562
Blue spring	DN65, DN80	210 ... 350 mbar	3142563
Red spring		25-80 mbar	3144252
Violet spring		60-120 mbar	3144253
Blue spring		100-220 mbar	3144254
White spring		200-450 mbar	3144255
Red spring		30-70 mbar	3144256
Violet spring	DN100	60-110 mbar	3144257
Brown spring		100-210 mbar	3144258
White spring		200-450 mbar	3144060

GAS FILTER



Size	Code
Rp1"1/2	3141954
Rp2"	3121384
DN65	3124111
DN80	3142088
DN100	3142205
DN125	3142206

OPTIONS**ANTIVIBRATION JOINT**

Size	Code
Rp1"1/4	3122324
Rp1"1/2	3122325
Rp2"	3122326
DN65	3142060
DN80	3122328
DN100	3122329
DN125	3142061

MANUAL VALVE

Size	Code
Rp1"1/4	3142253
Rp1"1/2	3142101
Rp2"	3142102
DN65	3142062
DN80	3143730
DN100	3141997
DN125	3141998

**MANOMETER +
PUSH BUTTON**

Description	Pressure range	Code
Gas manometer 1/2"	0...60 mbar	3142056
Gas manometer 1/4"	0...250 mbar	3142055
Gas manometer 1/4"	0...1000 mbar	3142054
Push button 1/2"		3142057
Push button 1/4"		3142058

- BLU models from 7000.1 to 18000.1 are monoblock force-draught burners working with natural gas or LPG and covering an output range from 1500 to 17000 kW
- These models are equipped with low NOx class 2 ($\text{NOx} \leq 120 \text{ mg/kWh}$) combustion heads according to the EN676 European Standard and are available in two stage progressive mechanical operation or modulating with the installation of a power regulator and dedicated probes
- Electronic versions are also available: see page 114
- As all the Ecoflam burners they are equipped with an adjustable combustion head for easy regulation and matching with different combustion chambers
- The structure of the burners allow easy access to the internal components for fast start-up and reduced maintenance time and space
- Multiple gas train matching are available according to the inlet gas pressure



WORKING DIAGRAM

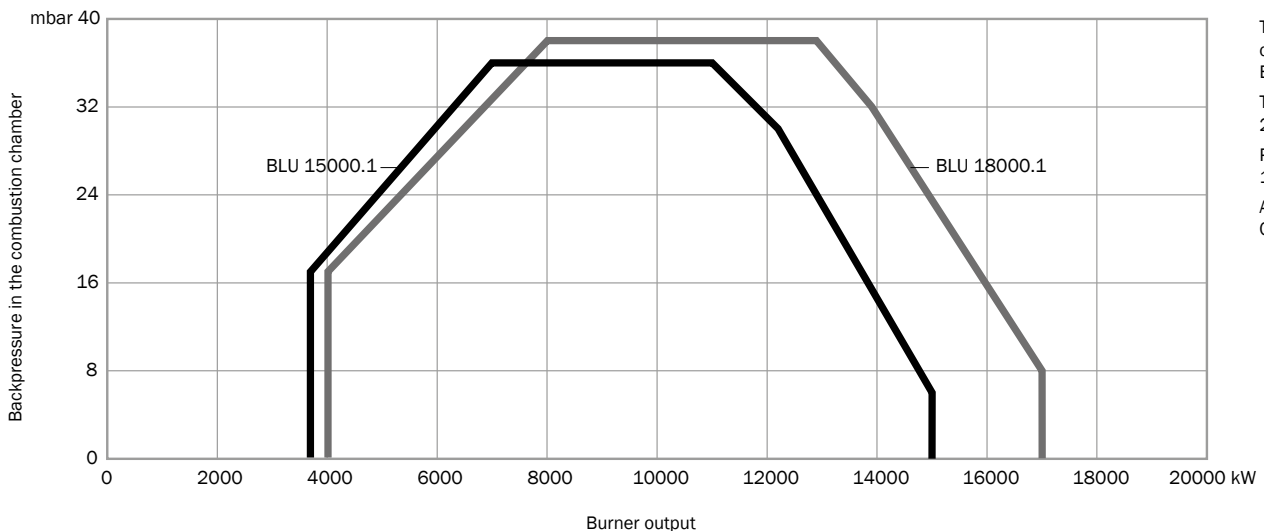
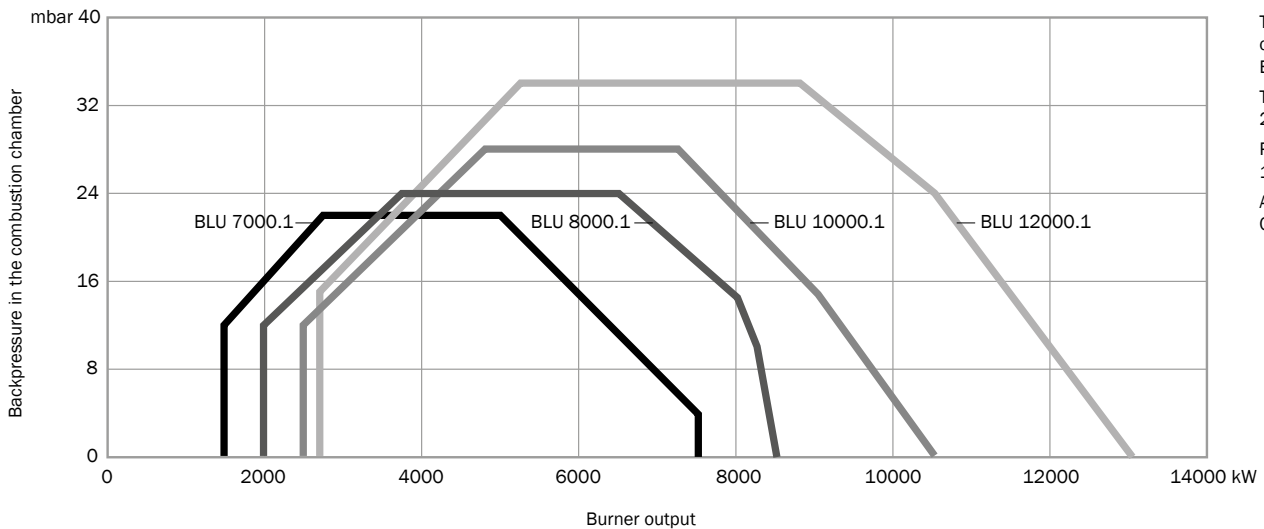

TECHNICAL DATA

Model	Operation	Output (kW)	Control box	Flame detector	Power supply	Motor (kW)	Emissions
BLU 7000.1	PR	1500 - 7500	LME73	Ionization	3/400/50Hz	15	Class 2
BLU 8000.1	PR	2000 - 8500	LME73	Ionization	3/400/50Hz	18,5	Class 2
BLU 10000.1	PR	2500 - 10500	LME73	Ionization	3/400/50Hz	22	Class 2
BLU 12000.1	PR	2700 - 13000	LME73	Ionization	3/400/50Hz	37	Class 2
BLU 15000.1	PR	3690 - 15000	LME73	Ionization	3/400/50Hz	45	Class 2
BLU 18000.1	PR	4000 - 17000	LME73	Ionization	3/400/50Hz	55	Class 2

CODES

■ PR - Two stage progressive/modulating mechanical

Model	TC	TL
BLU 7000.1 PR	3145875	on request
BLU 8000.1 PR	3145876	on request
BLU 10000.1 PR	3145877	on request
BLU 12000.1 PR	3145878	on request
BLU 15000.1 PR	3145879	on request
BLU 18000.1 PR	3145880	on request

OTHER AVAILABLE CONFIGURATIONS

- 60 Hz
- Continuous ventilation (CV)
- Post-purge
- Version for continuous operation
- Swirl system for flame geometry customization
- OEM and other special versions on request according to feasibility



All non-standard configurations are available on request: contact us to know more

OVERALL DIMENSIONS

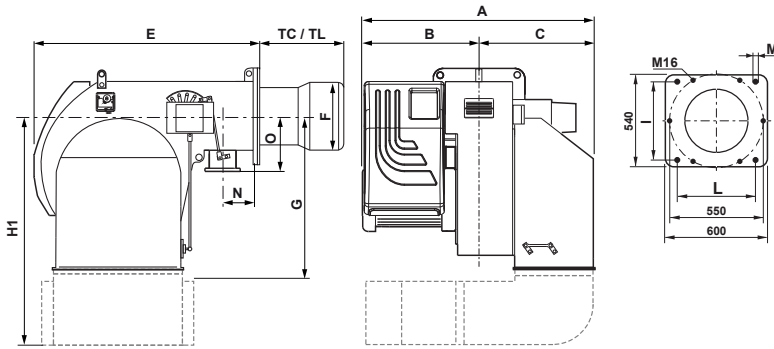

Model	A	B	C	TC	TL	E	F	G	H1 ¹	I	L	M	N	O
BLU 7000.1 PR	1210	585	625	470	-	1212	420	775	1270	460	460	M20	195	232
BLU 8000.1 PR	1280	655	625	470	-	1212	420	775	1270	460	460	M20	195	232
BLU 10000.1 PR	1310	685	625	470	-	1212	420	775	1270	460	460	M20	195	232
BLU 12000.1 PR	1420	795	625	470	-	1212	450	775	1270	460	460	M20	195	232

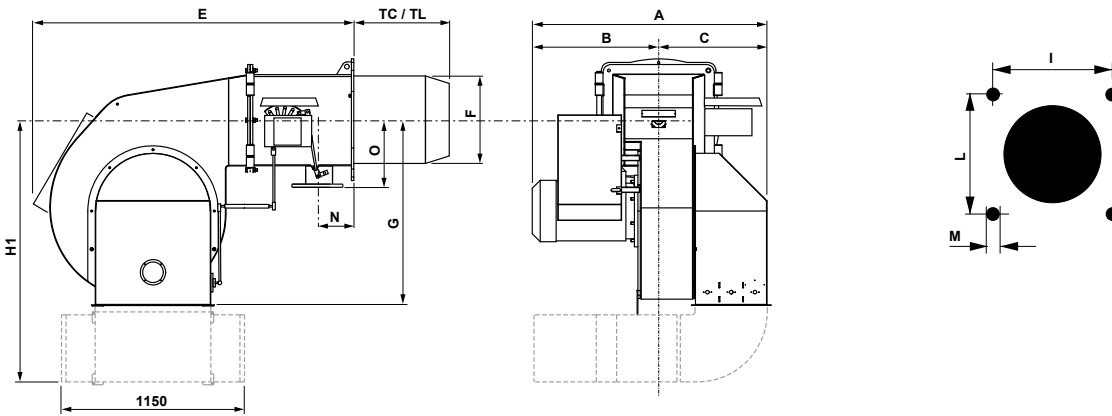

Model	A	B	C	TC	TL	E	F	G	H1 ¹	I	L	M	N	O
BLU 15000.1 PR	1530	810	720	590	-	1860	550	1320	1670	619	619	M20	210	320
BLU 18000.1 PR	1580	860	720	590	-	1860	550	1320	1670	619	619	M20	210	320

i Dimensions in mm
 Head length: TC short / TL long
¹: with silencer (optional)

PACKAGING

The complete burner with gas train and filter is delivered in a single wooden box containing boiler fixing accessories and a bag with technical documentation.

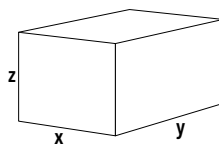

Model	x	y	z	kg
BLU 7000.1	1760	2390	1470	677
BLU 8000.1	1760	2390	1470	697
BLU 10000.1	1760	2390	1470	725
BLU 12000.1	1760	2390	1470	745
BLU 15000.1	2090	2800	1970	1321
BLU 18000.1	2090	2800	1970	1364

Dimensions in mm.
 Values referred to burners in standard version; the dimensions of the package may vary according to the configuration chosen

GAS TRAINS

Model	Pressure min-max	Model	Size	Codes	Connection pipe	Filter
for BLU 7000.1 PR	60 - 500	VDG 40.125	DN125	3146008	3145829	3142206
	75 - 500	VDG 40.100	DN100	3146007	3145822	3142205
	140 - 500	VDG 40.080	DN80	3146006	3145816	3142088
	280 - 500	VDG 40.065	DN65	3146005	3145801	3124111
for BLU 8000.1 PR	85 - 500	VDG 40.125	DN125	3146008	3145829	3142206
	110 - 500	VDG 40.100	DN100	3146007	3145822	3142205
	210 - 500	VDG 40.080	DN80	3146006	3145816	3142088
	410 - 500	VDG 40.065	DN65	3146005	3145801	3124111
for BLU 10000.1 PR	115 - 500	VDG 40.125	DN125	3146008	3145829	3142206
	165 - 500	VDG 40.100	DN100	3146007	3145822	3142205
	290 - 500	VDG 40.080	DN80	3146006	3145816	3142088
	550 - 500	VDG 40.065	DN65	3146005	3145801	3124111
for BLU 12000.1 PR	175 - 500	VDG 40.125	DN125	3146008	3145829	3142206
	230 - 500	VDG 40.100	DN100	3146007	3145822	3142205
	420 - 500	VDG 40.080	DN80	3146006	3145816	3142088
for BLU 15000.1 PR	150 - 500	VDG 40.125	DN125	3146008	3145829	3142206
	230 - 500	VDG 40.100	DN100	3146007	3145822	3142205
	450 - 500	VDG 40.080	DN80	3146006	3145816	3142088
for BLU 18000.1 PR	210 - 500	VDG 40.125	DN125	3146008	3145829	3142206
	330 - 500	VDG 40.100	DN100	3146007	3145822	3142205

- !** Default blank spring: head pressure 0...22 mbar; choose and change spring and damping (to be fitted during installation on site)
 For minimum inlet pressures higher than 250 mbar, choose the pressure switch GW500 (to be fitted during installation on site)
 For gas trains in EN676 Configuration a tightness control device must be included over 1200 kW

GAS TRAINS - DIMENSIONS

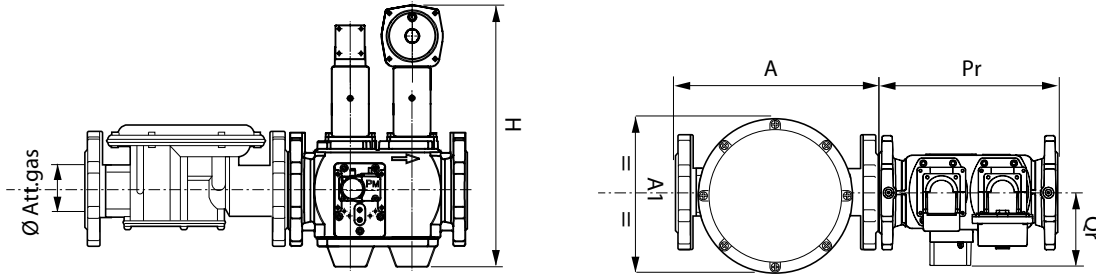

Code	Gas train	\varnothing	Dimensions (mm)		
			Pr	Qr	H
3146005	GT-S1-VGD40-DN65-PS3	DN65	290	127,3	421
3146006	GT-S1-VGD40-DN80-PS3	DN80	310	127,3	445
3146007	GT-S1-VGD40-DN100-PS3	DN100	350	145,4	476
3146008	GT-S1-VGD40-DN125-PS3	DN125	400	158,4	524

■ CONNECTION PIPE

Code	Dimensions (mm)		
	T	U	V
3145801	202	820	105
3145816	221	820	124
3145822	158	820	158
3145829	284	820	143

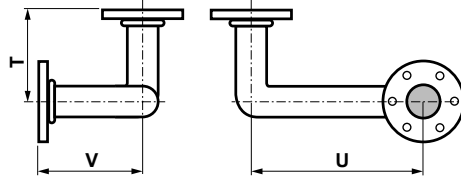

■ GAS FILTER

Code	\varnothing	Dimensions (mm)	
		A	A1
3124111	DN65	290	212
3142088	DN80	320	240
3142205	DN100	380	280
3142206	DN125	380	280

TOTAL DIMENSIONS CALCULATION

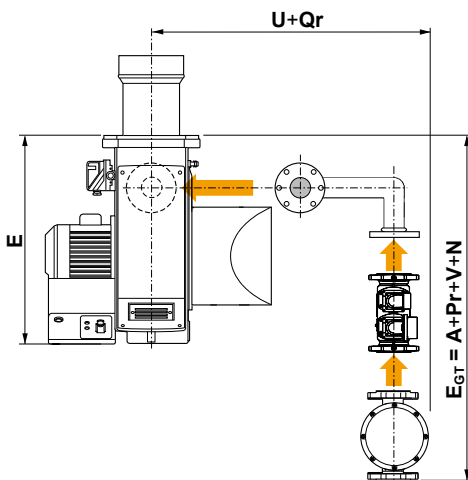

i To calculate the overall dimensions, consider the greater value between E and E_{GT}

OPTIONS

MODULATING PID CONTROLLER



Description	Code
Kit RWF50	3143713
Kit RWF55	3147787

i Kit supplied loose; on-board assembly available upon request
See page 257 for more information on RWF kit features

TEMPERATURE AND PRESSURE PROBES



Description	Code
Water probe, temperature range from 0 to 130 °C	3122316
Steam probe 0 ... 2 bar	3124100
Steam probe 0 ... 4 bar	3122317
Steam probe 0 ... 10 bar	3122318
Steam probe 0 ... 16 bar	3122319
Steam probe 0 ... 25 bar	3834314
Steam probe 0 ... 40 bar	3122320
Probe for external temperature from -35° to 50 °C	3122315
Hot air or liquid probe, temperature range from -50° to 400 °C	3122314
Thermocouple J type, temperature up to 750 °C (for RWF55 only)	3146725

CUSTOMER INTERFACE KIT DISPLAY

Description	Code
Kit display AZL21 for burners equipped with Siemens LME7	3148779

FREQUENCY CONVERTER



Description	Code	
15 kW	3757059	
18,5 kW	3757060	
IP21 with:	22 kW	3757061
• EMC filter	30 kW	3757062
• Inductor	37 kW	3757063
• Control panel	45 kW	3757064
55 kW	3757065	
15 kW	3757072	
18,5 kW	3757073	
IP55 with:	22 kW	3757074
• EMC filter	30 kW	3757075
• Inductor	37 kW	3757076
• Control panel	45 kW	3757077
55 kW	3757078	

TIGHTNESS CONTROL

! For gas trains in EN676 Configuration a tightness control device must be included over 1200 kW

Description	Code
Kit VPS504 for VGD DN65/80/100 valves, working with natural gas	3122303
Kit VPS504 for VGD DN65/80/100 valves, working with LPG	3142190
Kit VDK for VGD valve, DN125 size	3141922
Kit LDU	3142314
Adapter for VPS pilot gas train	3142754

OPTIONS

MAXIMUM GAS PRESSURE SWITCH

Description	Output range	Setting range	Code
Kit GPS 150	6 ... 15 MW	30 ... 150 mbar	3142033
Kit GPS 500	>15 MW	50 ... 500 mbar	3145166

GAS GOVERNOR WITH BUILT-IN FILTER

! Default spring is neutral for outlet pressure range 10 - 30 mbar

Size	Maximum gas pressure	Code
DN65	1 bar	3141983
DN80	1 bar	3142538
DN100	1 bar	on request
DN125	1 bar	on request

SPRINGS FOR GAS GOVERNOR

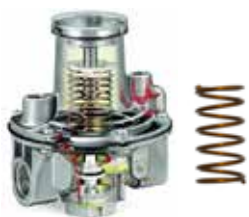

Description	Size	Gas pressure range	Code
Red spring	DN65, DN80	25-80 mbar	3144252
Violet spring		60-120 mbar	3144253
Blue spring		100-220 mbar	3144254
White spring		200-450 mbar	3144255
Red spring	DN100	30-70 mbar	3144256
Violet spring		60-110 mbar	3144257
Brown spring		100-210 mbar	3144258
White spring		200-450 mbar	3144060

GAS FILTER



Size	Code
DN65	3124111
DN80	3142088
DN100	3142205
DN125	3142206

ANTIVIBRATION JOINT



Size	Code
DN65	3142060
DN80	3122328
DN100	3122329
DN125	3142061

OPTIONS**MANUAL VALVE**

Size	Code
DN65	3142062
DN80	3143730
DN100	3141997
DN125	3141998

**MANOMETER +
PUSH BUTTON**

Description	Pressure range	Code
Gas manometer 1/2"	0...60 mbar	3142056
Gas manometer 1/4"	0...250 mbar	3142055
Gas manometer 1/4"	0...1000 mbar	3142054
Push button 1/2"		3142057
Push button 1/4"		3142058

- BLU models from 1000.1 to 6000.1 are monoblock force-draught burners working with natural gas or LPG and covering an output range from 245 to 6000 kW
- These models are equipped with low NOx class 2 ($\text{NO}_x \leq 120 \text{ mg/kWh}$) combustion heads according to the EN676 European Standard and are available in two stage progressive electronic operation with Burner Management System
- Models are fully electronically controlled for smooth operation and simple and effective programming operation
- The BLU .2 series has been designed with a new air/gas control system: the servomotor operates directly on the butterfly gas valve and the air damper is controlled through a mechanical leverage connected to the cam; this system allows a more precise regulation of the air damper following the gas valve setting made through the servomotor
- All models are also available in FCA version, equipped with frequency converter arrangement
- A tightness control device is integrated for all electronic burners
- As all the Ecoflam burners they are equipped with an adjustable combustion head for easy regulation and matching with different combustion chambers
- The structure of the burners allow easy access to the internal components for fast start-up and reduced maintenance time and space
- Multiple gas train matching are available according to the inlet gas pressure



WORKING DIAGRAM

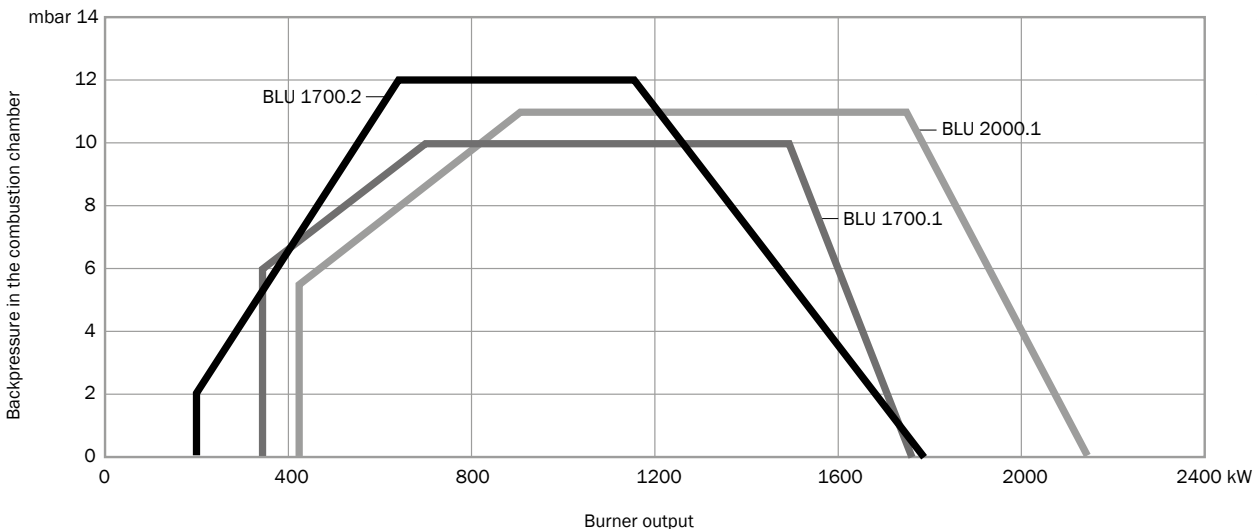
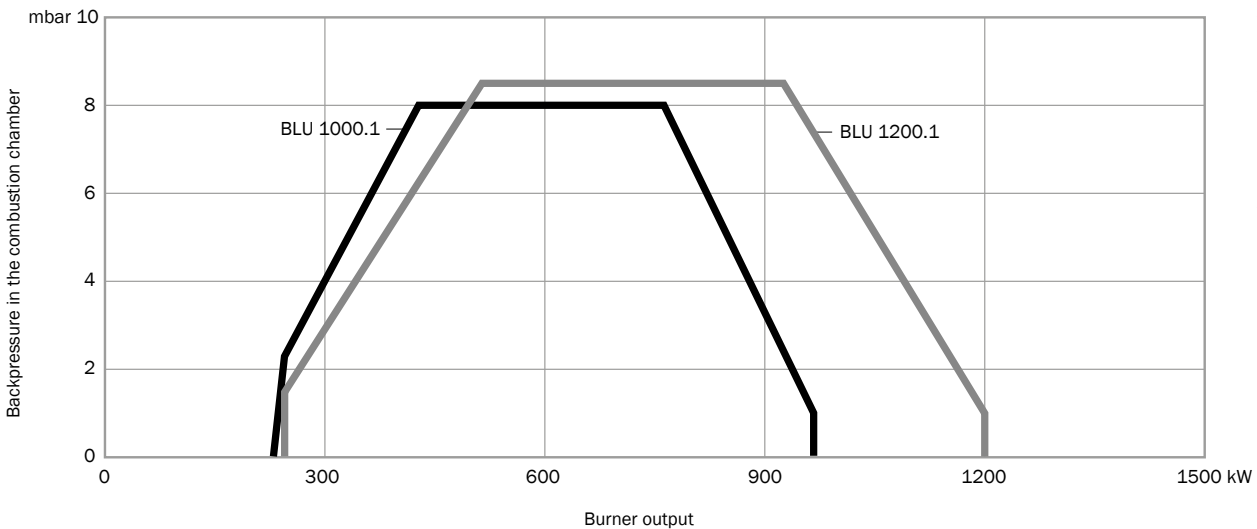

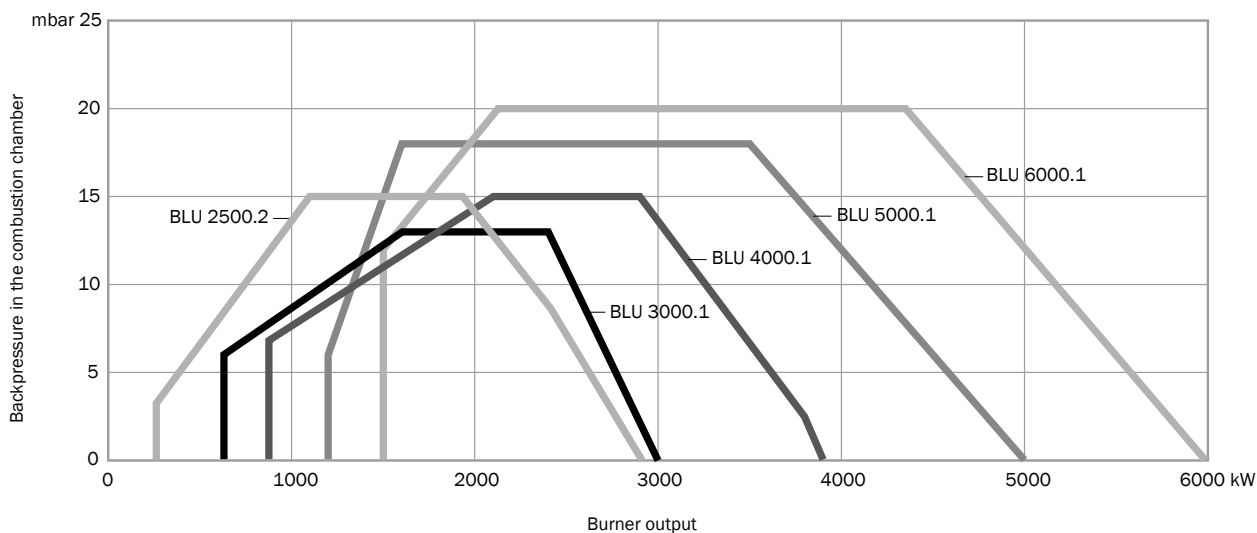

TECHNICAL DATA

Model	Operation	Output (kW)	Control box	Flame detector	Power supply	Motor (kW)	Emissions
BLU 1000.1	PRE PRE FCA	245 - 970	BT320	Ionization	3/230-400/50Hz	1,1	Class 2
BLU 1200.1	PRE PRE FCA	260 - 1200	BT320	Ionization	3/230-400/50Hz	2,2	Class 2
BLU 1700.1	PRE PRE FCA	342 - 1770	BT320	Ionization	3/230-400/50Hz	3	Class 2
BLU 1700.2	PRE -	200 - 1780	BT320	Ionization	3/230-400/50Hz	2,2	Class 2
BLU 2000.1	PRE PRE FCA	414 - 2150	BT320	Ionization	3/400/50Hz	4	Class 2
BLU 2500.2	PRE PRE FCA	290 - 2950	BT320	Ionization	3/400/50Hz	4	Class 2
BLU 3000.1	PRE PRE FCA	630 - 3000	BT320	Ionization	3/400/50Hz	5,5	Class 2
BLU 4000.1	PRE PRE FCA	875 - 3900	BT320	Ionization	3/400/50Hz	7,5	Class 2
BLU 5000.1	PRE PRE FCA	1200 - 5000	BT320	Ionization	3/400/50Hz	11	Class 2
BLU 6000.1	PRE PRE FCA	1500 - 6000	BT320	Ionization	3/400/50Hz	15	Class 2

CODES

■ PRE - Two stage progressive/modulating electronic

Model	TC	TL
BLU 1000.1 PRE	3145116	3145117
BLU 1200.1 PRE	3145118	3145119
BLU 1700.1 PRE	3145120	3145121
BLU 1700.2 PRE	3147666	3147667
BLU 2000.1 PRE	3145122	3145123
BLU 2500.2 PRE	3147670	3147671
BLU 3000.1 PRE	3145124	3145125
BLU 4000.1 PRE	3145126	3145127
BLU 5000.1 PRE	3145128	3145129
BLU 6000.1 PRE	3145130	3145131

■ PRE FCA - Two stage progressive/modulating electronic with frequency converter arrangement

Model	TC	TL
BLU 1000.1 PRE FCA	3148360	3148361
BLU 1200.1 PRE FCA	3148362	3148363
BLU 1700.1 PRE FCA	3148364	3148365
BLU 2000.1 PRE FCA	3148366	3148367
BLU 2500.2 PRE FCA	3148368	3148369
BLU 3000.1 PRE FCA	3148370	3148371
BLU 4000.1 PRE FCA	3148372	3148373
BLU 5000.1 PRE FCA	3148374	3148375
BLU 6000.1 PRE FCA	3148376	3148377

OTHER AVAILABLE CONFIGURATIONS

- 60 Hz
- Continuous ventilation (CV)
- Post-purge
- LPG version (starting from BLU 1700.1)
- Swirl system for flame geometry customization
- OEM and other special versions on request according to feasibility



All non-standard configurations are available on request: contact us to know more

OVERALL DIMENSIONS

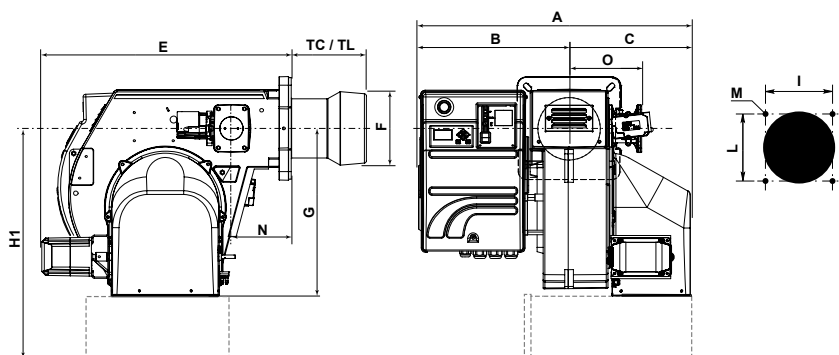

i Dimensions in mm
 Head length: TC short / TL long
 *: with silencer (optional)

Model	A	B	C	TC	TL	E	F	G	H1 ¹	I	L	M	N	O
BLU 1000.1 PRE	663	383	280	174	395	543	190	401	601	185/200	185/200	M10	138	168
BLU 1200.1 PRE	663	383	280	309	459	543	200	401	601	185/200	185/200	M10	138	168
BLU 1700.2 PRE	642	328	314	348	500	543	225	401	601	185/200	185/200	M10	138	168

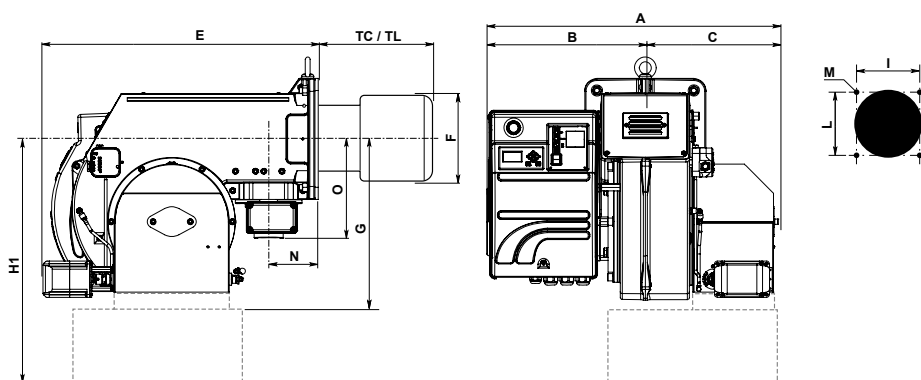

Model	A	B	C	TC	TL	E	F	G	H1 ¹	I	L	M	N	O
BLU 1700.1 PRE	724	393	331	340	540	682	250	420	680	240	240	M14	125	250
BLU 2000.1 PRE	724	393	331	345	545	682	270	420	680	240	240	M14	125	250
BLU 2500.2 PRE	753	424	329	380	580	692	300	420	680	315	315	M16	133	245
BLU 3000.1 PRE	941	448	493	330	530	780	290	471	746	315	315	M16	195	250
BLU 4000.1 PRE	941	448	493	365	565	780	320	471	746	315	315	M16	195	250
BLU 5000.1 PRE	1120	596	524	375	575	930	320	570	965	330	330	M16	195	250
BLU 6000.1 PRE	1120	596	524	375	575	930	360	570	965	330	330	M16	195	250

PACKAGING

The complete burner with gas train and filter is delivered in a carton box containing boiler fixing accessories and a bag with technical documentation.

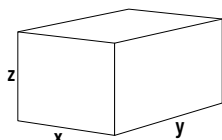

Model	x	y	z	kg
BLU 1000.1	800	1070	590	50
BLU 1200.1	800	1200	590	59
BLU 1700.1	930	1300	760	101
BLU 1700.2	800	1200	590	105
BLU 2000.1	930	1300	760	118
BLU 2500.2	930	1300	760	129
BLU 3000.1	1150	1380	960	228
BLU 4000.1	1150	1700	930	242
BLU 5000.1	1590	1590	1080	350
BLU 6000.1	1590	1590	1080	372

Dimensions in mm.
 Values referred to burners in standard version; the dimensions of the package may vary according to the configuration chosen

GAS TRAINS

Model	Pressure (mbar) min - max	Model	Size	Codes	Connection pipe	Filter
for BLU 1000.1 PRE	27 - 360	MB-DLE 420	2"	3145934	-	included
	35 - 360	MB-DLE 415	1"1/2	3145933		included
	75 - 360	MB-DLE 412	1"1/4	3145932		included
for BLU 1200.1 PRE	25 - 500	VGD 20.503	2"	3145790	-	3121384
	40 - 360	MB-DLE 420	2"	3145934		included
	50 - 360	MB-DLE 415	1"1/2	3145933		included
	100 - 360	MB-DLE 412	1"1/4	3145932		included
for BLU 1700.1 PRE	20 - 500	VGD 40.080	DN80	3145814	3145815	3142088
	45 - 500	VGD 20.503	2"	3145790	4396172	3121384
	60 - 360	MB-DLE 420	2"	3145934	4396172	included
	85 - 360	MB-DLE 415	1"1/2	3145933	4396172	included
for BLU 1700.2 PRE	20 - 500	VGD 40.080	DN80	3147674	3147160	3142088
	35 - 500	VGD 40.065	DN65	3147673	3147159	3124111
	45 - 500	VGD 20.5011	2"	3147672	-	3121384
	60 - 360	MB-DLE 420	2"	3144929	-	included
	85 - 360	MB-DLE 415	1"1/2	3144928	-	included
for BLU 2000.1 PRE	23 - 500	VGD 40.080	DN80	3145814	3145815	3142088
	35 - 500	VGD 40.065	DN65	3145793	3145800	3124111
	60 - 500	VGD 20.503	2"	3145790	4396172	3121384
	75 - 360	MB-DLE 420	2"	3145934	4396172	included
	100 - 360	MB-DLE 415	1"1/2	3145933	4396172	included
for BLU 2500.2 PRE	35 - 500	VGD 40.080	DN80	3147674	3144686 + 3147160	3142088
	55 - 500	VGD 40.065	DN65	3147673	3144686 + 3147159	3124111
	100 - 500	VGD 20.5011	2"	3147672	3144686	3121384
for BLU 3000.1 PRE	22 - 500	VGD 40.100	DN100	3145817	3145820	3142205
	35 - 500	VGD 40.080	DN80	3145814	3145815	3142088
	55 - 500	VGD 40.065	DN65	3145793	3145800	3124111
	100 - 500	VGD 20.503	2"	3145790	4396173	3121384
for BLU 4000.1 PRE	30 - 500	VGD 40.100	DN100	3145817	3145820	3142205
	50 - 500	VGD 40.080	DN80	3145814	3145815	3142088
	90 - 500	VGD 40.065	DN65	3145793	3145800	3124111
	170 - 500	VGD 20.503	2"	3145790	4396173	3121384
for BLU 5000.1 PRE	35 - 500	VGD 40.125	DN125	3145823	3145830	3142206
	45 - 500	VGD 40.100	DN100	3145817	3145821	3142205
	75 - 500	VGD 40.080	DN80	3145814	3145864	3142088
	140 - 500	VGD 40.065	DN65	3145793	3145997	3124111
	250 - 500	VGD 20.503	2"	3145790	4396173	3121384
for BLU 6000.1 PRE	50 - 500	VGD 40.125	DN125	3145823	3145830	3142206
	60 - 500	VGD 40.100	DN100	3145817	3145821	3142205
	100 - 500	VGD 40.080	DN80	3145814	3145864	3142088
	180 - 500	VGD 40.065	DN65	3145793	3145997	3124111
	340 - 500	VGD 20.503	2"	3145790	4396173	3121384



Default blank spring: head pressure 0...22 mbar; choose and change spring and damping (to be fitted during installation on site)
 For minimum inlet pressures higher than 250 mbar, choose the pressure switch GW500 (to be fitted during installation on site)
 A tightness control device is included (For gas trains in EN676 Configuration it is mandatory over 1200 kW)

GAS TRAINS - DIMENSIONS

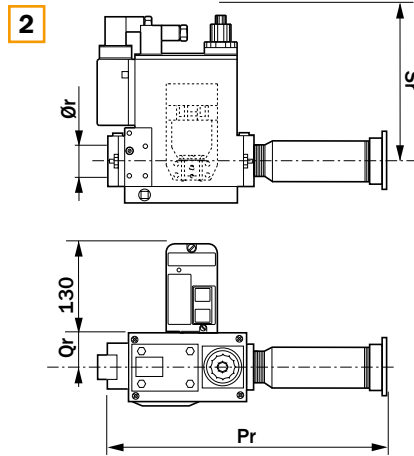
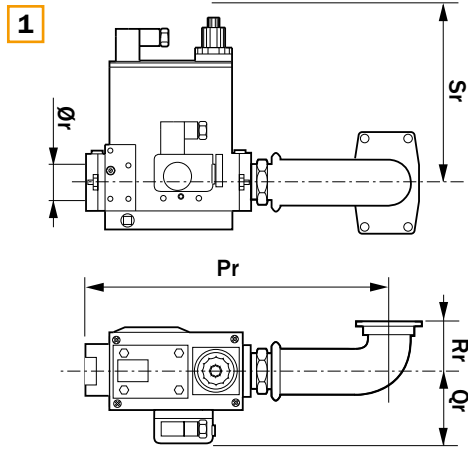

Code	Gas train	Ø	Pic.	Dimensions (mm)				
				Pr	Qr	Rr	Sr	Ør
3144928	GT-D1-MBDLE415-RP40-PS2	Rp1"1/2	2	592	50	-	169	1"1/2
3144929	GT-D1-MBDLE420-RP50-PS2	Rp2"	2	410	90	-	217	2"
3145932	GT-D1-MBDLE412-RP32-PS2	Rp1"1/4	1	330	102	85	160	1"1/4
3145933	GT-D1-MBDLE415-RP40-PS2	Rp1"1/2	1	410	90	85	175	1"1/2
3145934	GT-D1-MBDLE420-RP50-PS2	Rp2"	1	420	90	85	175	2"

■ CONNECTION PIPE

Code	Dimensions (mm)	
	T	U
4396172	85	400

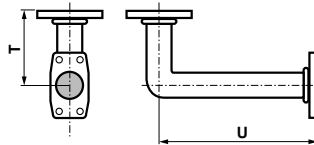

■ TOTAL DIMENSIONS CALCULATION

BLU 1000.1, BLU 1200.1

BLU 1700.2

BLU 1700.1, BLU 2000.1

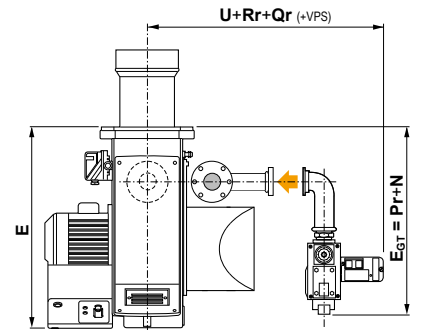
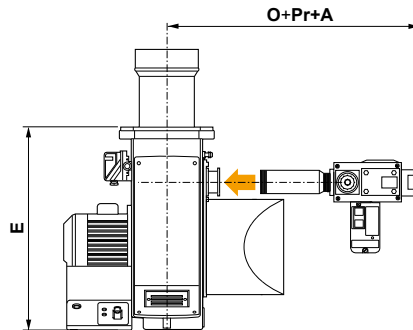
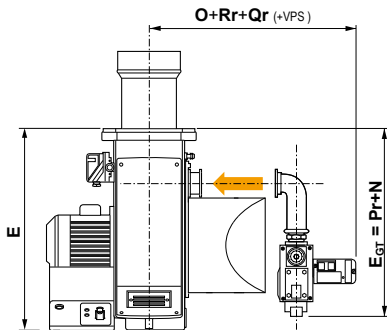

i To calculate the overall dimensions, consider the greater value between E and E_{GT}

GAS TRAINS - DIMENSIONS

■ VGD 20... PS2-S

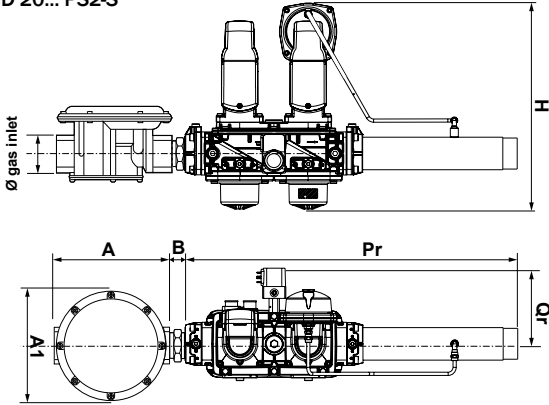

■ VGD 40... PS2-S

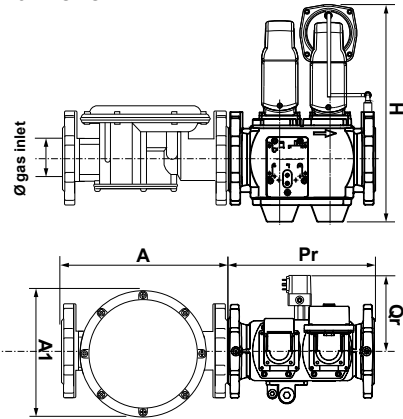

Code	Model	Ø	Dimensions (mm)			
			Pr	Qr	H	B
3147672	GT-S1-VGD20-RP50-PS2-S	Rp2"	628	34,9	382	36
3147673	GT-S1-VGD40-DN65-PS2-S	DN65	290	125,8	421	-
3147674	GT-S1-VGD40-DN80-PS2-S	DN80	310	127,3	445	-

■ VGD 20... PS2

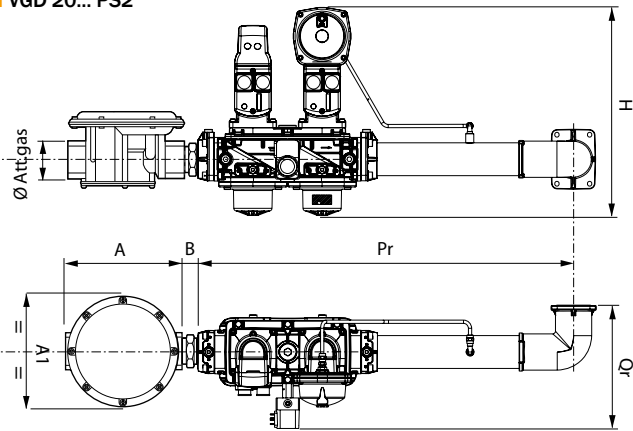

■ VGD 40... PS2

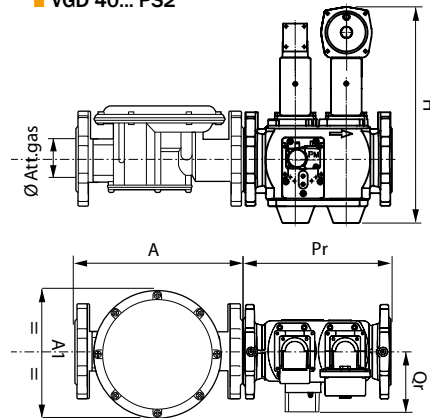

Code	Gas train	Ø	Dimensions (mm)			
			Pr	Qr	H	B
3145790	GT-S1-VGD20-RP50-PS2	Rp2"	689	226	382	36
3145793	GT-S1-VGD40-DN65-PS2	DN65	290	127,3	421	-
3145814	GT-S1-VGD40-DN80-PS2	DN80	310	127,3	445	-
3145817	GT-S1-VGD40-DN100-PS2	DN100	350	145,4	476	-
3145823	GT-S1-VGD40-DN125-PS2	DN125	400	158,4	524	-

GAS TRAINS - DIMENSIONS

CONNECTION PIPE

Code	Pic.	Dimensions (mm)		
		T	U	V
4396172	1	85	450	-
4396173	1	85	580	-
3144686	3	100	32	-
3145800	2	101	560	101
3145815	2	122	560	122
3145820	2	248	560	122
3145821	2	122	668	122
3145830	2	156	718	122
3145864	2	122	668	122
3145997	2	122	668	122
3147159	4	-	500	-
3147160	5	-	500	-

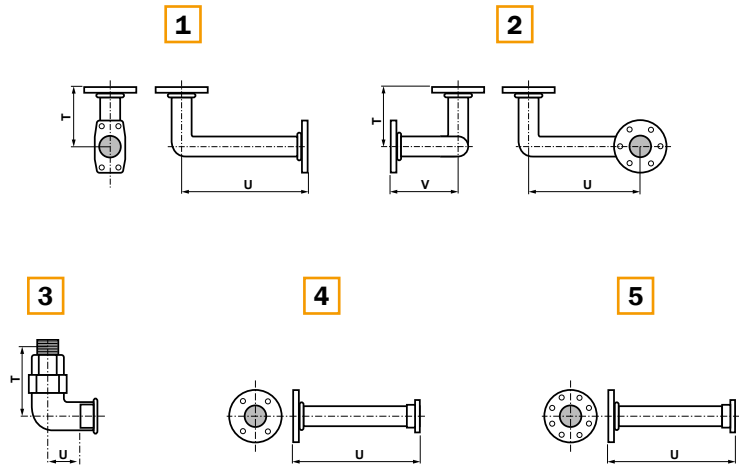

GAS FILTER

Code	Ø	Dimensions (mm)		
		A	A1	B
3121384	Rp2"	186	186	>100
3124111	DN65	290	212	-
3142088	DN80	320	240	-
3142205	DN100	380	280	-
3142206	DN125	380	280	-

TOTAL DIMENSIONS CALCULATION

BLU 1000.1, BLU 1200.1

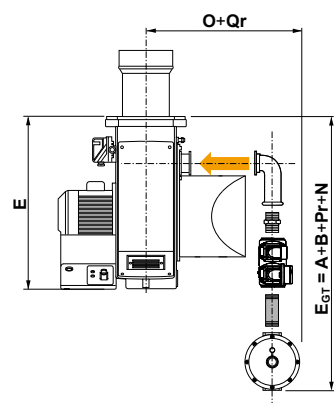

BLU 1700.1 ... 6000.1

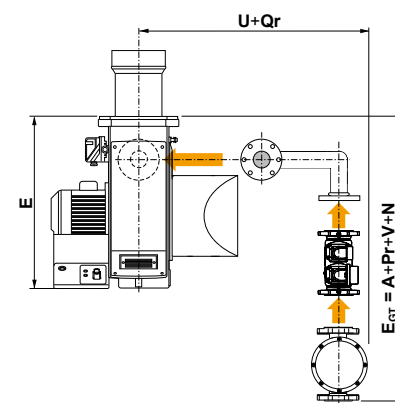

i To calculate the overall dimensions, consider the greater value between E and E_{GT}

BLU 1700.2

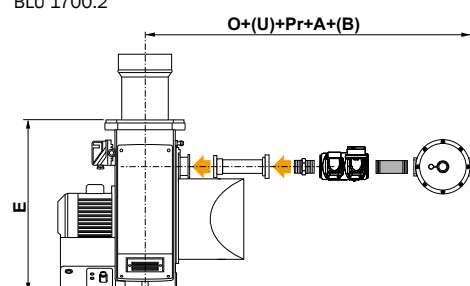

BLU 2500.2

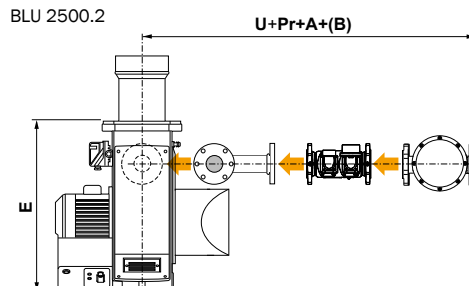

OPTIONS**MODULATING
PID CONTROLLER**

Description	Code
Kit RWF50	3143713
Kit RWF55	3143714

i Kit supplied loose; on-board assembly available upon request
See page 257 for more information on RWF kit features

**TEMPERATURE AND
PRESSURE PROBES**

Description	Code
Water probe, temperature range from 0 to 130 °C	3122316
Steam probe 0 ... 2 bar	3124100
Steam probe 0 ... 4 bar	3122317
Steam probe 0 ... 10 bar	3122318
Steam probe 0 ... 16 bar	3122319
Steam probe 0 ... 25 bar	3834314
Steam probe 0 ... 40 bar	3122320
Probe for external temperature from -35° to 50 °C	3122315
Hot air or liquid probe, temperature range from -50° to 400 °C	3122314
Thermocouple J type, temperature up to 750 °C (for RWF55 only)	3146725

**FREQUENCY
CONVERTER**

Description	Code
3 kW	3757054
4 kW	3757055
IP21 with: • EMC filter	5,5 kW
• Inductor	7,5 kW
• Control panel	11 kW
	15 kW
3 kW	3757067
4 kW	3757068
IP55 with: • EMC filter	5,5 kW
• Inductor	7,5 kW
• Control panel	11 kW
	15 kW

KIT LPG

Description	Code
LPG conversion kit for gas burners for BLU 1000.1 / 1200.1	3144610

**MAXIMUM GAS
PRESSURE SWITCH**

Description	Output range	Setting range	Code
Kit GPS 150	<15 MW	5 ... 150 mbar	3147771

OPTIONS

GAS GOVERNOR WITH BUILT-IN FILTER

! Default spring is neutral for outlet pressure range 10 - 30 mbar

Size	Maximum gas pressure	Code
Rp1"1/4	500 mbar	3142522
Rp1"1/2	500 mbar	3142523
Rp2"	500 mbar	3142524
Rp2"	1 bar	3142051
DN65	1 bar	3141983
DN80	1 bar	3142538
DN100	1 bar	on request
DN125	1 bar	on request

SPRINGS FOR GAS GOVERNOR



Description	Size	Gas pressure range	Code
Green spring	1"1/4, 1"1/2	5 ... 15 mbar	3142553
Neutral spring		10 ... 30 mbar	3142554
Violet spring		20 ... 70 mbar	3142555
Brown spring		65 ... 130 mbar	3142556
White spring		120 ... 250 mbar	3142557
Black spring		240 ... 350 mbar	3142558
Green spring	2"	5 ... 15 mbar	3142559
Neutral spring		10 ... 30 mbar	3142560
Violet spring		30 ... 80 mbar	3142561
Brown spring		70 ... 220 mbar	3142562
Blue spring		210 ... 350 mbar	3142563
Red spring	DN65, DN80	25-80 mbar	3144252
Violet spring		60-120 mbar	3144253
Blue spring		100-220 mbar	3144254
White spring		200-450 mbar	3144255
Red spring	DN100	30-70 mbar	3144256
Violet spring		60-110 mbar	3144257
Brown spring		100-210 mbar	3144258
White spring		200-450 mbar	3144060

GAS FILTER



Size	Code
Rp1"1/2	3141954
Rp2"	3121384
DN65	3124111
DN80	3142088
DN100	3142205
DN125	3142206

OPTIONS**ANTIVIBRATION JOINT**

Size	Code
Rp1"1/4	3122324
Rp1"1/2	3122325
Rp2"	3122326
DN65	3142060
DN80	3122328
DN100	3122329
DN125	3142061

MANUAL VALVE

Size	Code
Rp1"1/4	3142253
Rp1"1/2	3142101
Rp2"	3142102
DN65	3142062
DN80	3143730
DN100	3141997
DN125	3141998

MANOMETER + PUSH BUTTON

Description	Pressure range	Code
Gas manometer 1/2"	0...60 mbar	3142056
Gas manometer 1/4"	0...250 mbar	3142055
Gas manometer 1/4"	0...1000 mbar	3142054
Push button 1/2"		3142057
Push button 1/4"		3142058

LCM MODULE

Description	Code
LCM module mounted in factory for communication via BUS, O ₂ control and frequency converter	3146795

REMOTE SOFTWARE

Description	Code
Kit to connect a PC to the BT300 for its parametrization (LSA100 + USB/CAN + CD-Rom)	3751130

COMMUNICATION MODULES

Description	Code	
Additional module for BT3 (supplied loose)	ModBus/BT3	on request
	ProfiBus/BT3	on request
	Ethernet/BT3	on request

OPTIONS

O₂ TRIM

Flue temp max 300 °C
 Display for O₂ visualization
 The kit includes:

- Lambda transmitter LT3
- Lambda probe LS2
- Probe installation fitting
- Gas extraction device



! For models equipped with BT3 this kit needs a LCM module installed in the burner control panel

Additional LSB modules installed at LT3	GED length	Code
None	150 mm	3759296
	300 mm	3759297
	450 mm	3759298
4x 0/4-20 mA output	150 mm	3759299
	300 mm	3759300
	450 mm	3759301
4x 0/4-20 mA output + 4x digital output	150 mm	3759302
	300 mm	3759303
	450 mm	3759304

Description	Code	
Extension for LS2	5m ready-made cable	3759318
	PCB (probe connection box) ¹	3759319

O₂ AND CO TRIM

Flue temp max 300 °C
 The kit includes:

- Lambda transmitter LT3-F
- Lambda probe KS1D
- Probe installation fitting
- Gas extraction device

! For models equipped with BT3 this kit needs a LCM module installed in the burner control panel

Additional LSB modules installed at LT3-F	GED length	Code
none	150 mm	3759305
	300 mm	3759306
	450 mm	3759307
4x 0/4-20 mA output	150 mm	3759308
	300 mm	3759309
	450 mm	3759310
4x 0/4-20 mA output + 4x digital output	150 mm	3759311
	300 mm	3759312
	450 mm	3759313

Description	Code	
Extension for KS1D	5m ready-made cable	3759318
	PCB (probe connection box) ¹	3759319

! ¹: The PCB is mandatory if the end user chooses to use his own connecting cable and not one of those proposed above
 See page 260 for further information

- BLU models from 7000.1 to 18000.1 are monoblock force-draught burners working with natural gas or LPG and covering an output range from 1500 to 17000 kW
- These models are available in two stage progressive electronic with Burner Management System
- Models are fully electronically controlled for smooth operation and simple and effective programming operation
- Tightness control is integrated for all electronic burners
- As all the Ecoflam burners they are equipped with an adjustable combustion head for easy regulation and matching with different combustion chambers
- The structure of the burners allow easy access to the internal components for fast start-up and reduced maintenance time and space
- Multiple gas train matching are available according to the inlet gas pressure



WORKING DIAGRAM

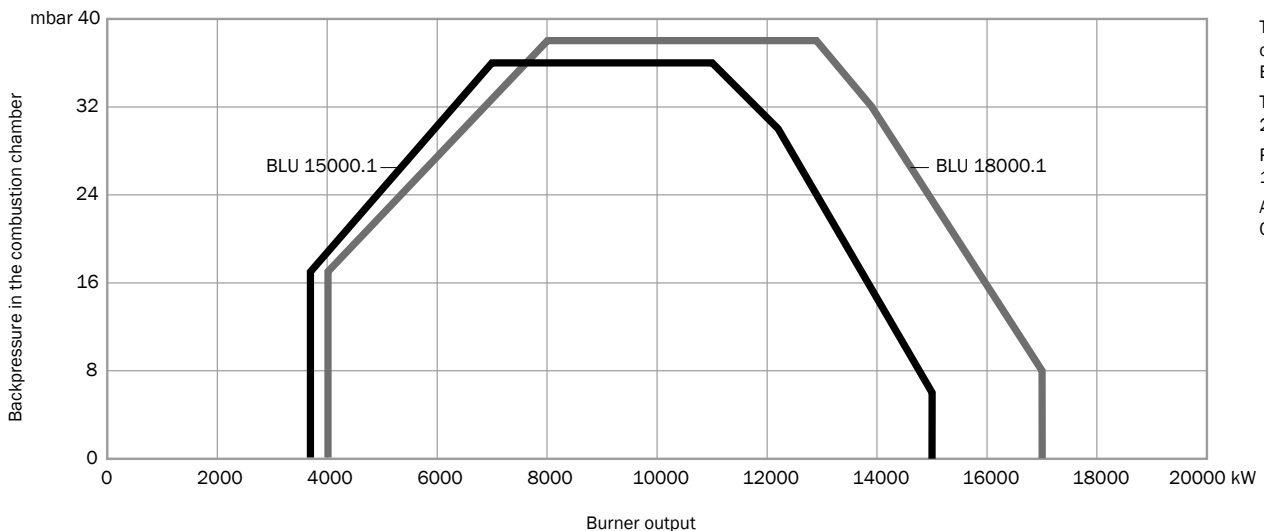
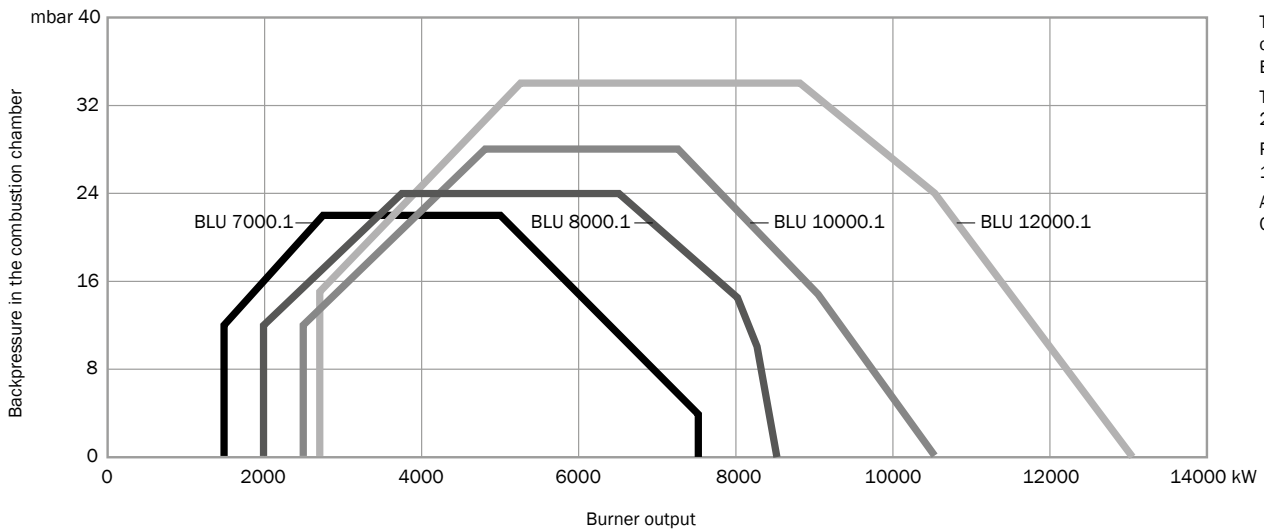

TECHNICAL DATA

Model	Operation	Output (kW)	Control box	Flame detector	Power supply	Motor (kW)	Emissions
BLU 7000.1	PRE PRE FCA	1500 - 7500	BT320	Ionization	3/400/50Hz	15	Class 2
BLU 8000.1	PRE PRE FCA	2000 - 8500	BT320	Ionization	3/400/50Hz	18,5	Class 2
BLU 10000.1	PRE PRE FCA	2500 - 10500	BT320	Ionization	3/400/50Hz	22	Class 2
BLU 12000.1	PRE PRE FCA	2700 - 13000	BT320	Ionization	3/400/50Hz	37	Class 2
BLU 15000.1	PRE PRE FCA	3690 - 15000	BT320	Ionization	3/400/50Hz	45	Class 2
BLU 18000.1	PRE PRE FCA	4000 - 17000	BT320	Ionization	3/400/50Hz	55	Class 2

CODES

■ PRE - Two stage progressive/modulating electronic

Model	TC	TL
BLU 7000.1 PRE	3145132	on request
BLU 8000.1 PRE	3145133	on request
BLU 10000.1 PRE	3145134	on request
BLU 12000.1 PRE	3145135	on request
BLU 15000.1 PRE	3145136	on request
BLU 18000.1 PRE	3145137	on request

■ PRE FCA - Two stage progressive/modulating electronic with frequency converter arrangement

Model	TC	TL
BLU 7000.1 PRE FCA	3148378	on request
BLU 8000.1 PRE FCA	3148380	on request
BLU 10000.1 PRE FCA	3148382	on request
BLU 12000.1 PRE FCA	3148384	on request
BLU 15000.1 PRE FCA	3148386	on request
BLU 18000.1 PRE FCA	3148388	on request

OTHER AVAILABLE CONFIGURATIONS

- 60 Hz
- Continuous ventilation (CV)
- Post-purge
- Swirl system for flame geometry customization
- OEM and other special versions on request according to feasibility

i All non-standard configurations are available on request: contact us to know more

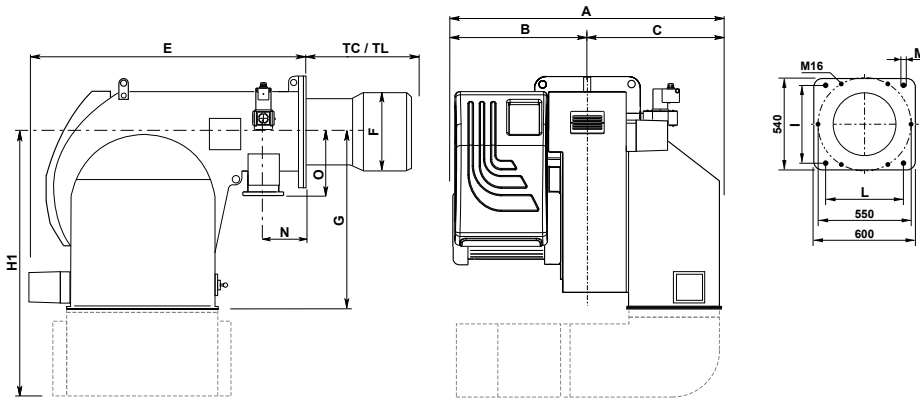
OVERALL DIMENSIONS

Model	A	B	C	TC	TL	E	F	G	H1 ¹	I	L	M	N	O
BLU 7000.1	1210	585	625	470	-	1212	420	775	1270	460	460	M20	195	232
BLU 8000.1	1280	655	625	470	-	1212	420	775	1270	460	460	M20	195	232
BLU 10000.1	1310	685	625	470	-	1212	420	775	1270	460	460	M20	195	232
BLU 12000.1	1420	795	625	470	-	1212	450	775	1270	460	460	M20	195	232

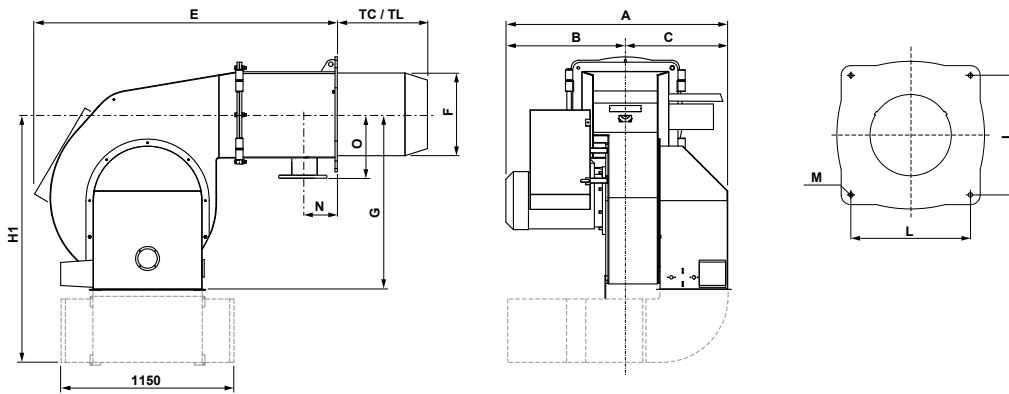

Model	A	B	C	TC	TL	E	F	G	H1 ¹	I	L	M	N	O
BLU 15000.1	1530	810	720	590	-	1860	550	1320	1670	619	619	M20	210	320
BLU 18000.1	1580	860	720	590	-	1860	550	1320	1670	619	619	M20	210	320

i Dimensions in mm
 Head length: TC short / TL long
¹: with silencer (optional)

PACKAGING

The complete burner with gas train and filter is delivered in a single wooden box containing boiler fixing accessories and a bag with technical documentation.

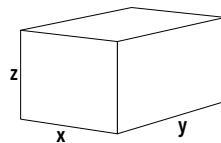

Model	x	y	z	kg
BLU 7000.1	1760	2390	1470	677
BLU 8000.1	1760	2390	1470	697
BLU 10000.1	1760	2390	1470	725
BLU 12000.1	1760	2390	1470	745
BLU 15000.1	2090	2800	1970	1321
BLU 18000.1	2090	2800	1970	1364

Dimensions in mm.

Values referred to burners in standard version; the dimensions of the package may vary according to the configuration chosen

GAS TRAINS

Model	Pressure (mbar) min-max	Model	Size	Codes	Connection pipe	Filter
for BLU 7000.1 PRE	60 - 500	VGD 40.125	DN125	3145823	3145829	3142206
	75 - 500	VGD 40.100	DN100	3145817	3145822	3142205
	140 - 500	VGD 40.080	DN80	3145814	3145816	3142088
	280 - 500	VGD 40.065	DN65	3145793	3145801	3124111
for BLU 8000.1 PRE	85 - 500	VGD 40.125	DN125	3145823	3145829	3142206
	110 - 500	VGD 40.100	DN100	3145817	3145822	3142205
	210 - 500	VGD 40.080	DN80	3145814	3145816	3142088
	410 - 500	VGD 40.065	DN65	3145793	3145801	3124111
for BLU 10000.1 PRE	115 - 500	VGD 40.125	DN125	3145823	3145829	3142206
	165 - 500	VGD 40.100	DN100	3145817	3145822	3142205
	290 - 500	VGD 40.080	DN80	3145814	3145816	3142088
	550 - 500	VGD 40.065	DN65	3145793	3145801	3124111
for BLU 12000.1 PRE	175 - 500	VGD 40.125	DN125	3145823	3145829	3142206
	230 - 500	VGD 40.100	DN100	3145817	3145822	3142205
	420 - 500	VGD 40.080	DN80	3145814	3145816	3142088
for BLU 15000.1 PRE	150 - 500	VGD 40.125	DN125	3145823	3145829	3142206
	230 - 500	VGD 40.100	DN100	3145817	3145822	3142205
	450 - 500	VGD 40.080	DN80	3145814	3145816	3142088
for BLU 18000.1 PRE	210 - 500	VGD 40.125	DN125	3145823	3145829	3142206
	330 - 500	VGD 40.100	DN100	3145817	3145822	3142205

- !** Default blank spring: head pressure 0...22 mbar; choose and change spring and damping (to be fitted during installation on site)
 For minimum inlet pressures higher than 250 mbar, choose the pressure switch GW500 (to be fitted during installation on site)
 A tightness control device is included (For gas trains in EN676 Configuration it is mandatory over 1200 kW)

GAS TRAINS - DIMENSIONS

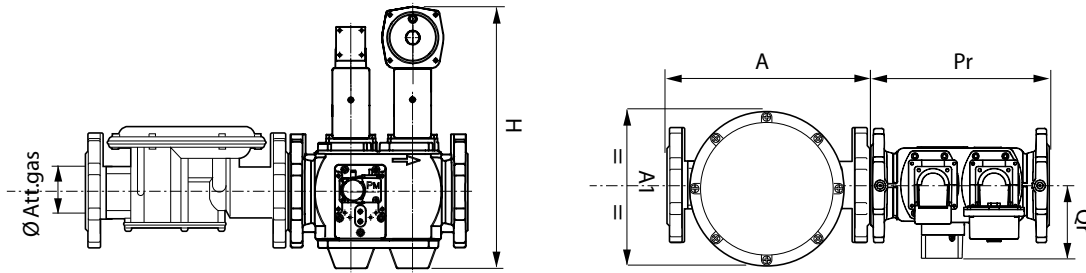

Code	Gas train	\varnothing	Dimensions (mm)		
			Pr	Qr	H
3145793	GT-S1-VGD40-DN65-PS2	DN65	290	127,3	421
3145814	GT-S1-VGD40-DN80-PS2	DN80	310	127,3	445
3145817	GT-S1-VGD40-DN100-PS2	DN100	350	145,4	476
3145823	GT-S1-VGD40-DN125-PS2	DN125	400	158,4	524

■ CONNECTION PIPE

Code	Dimensions (mm)		
	T	U	V
3145801	202	820	105
3145816	221	820	124
3145822	158	820	158
3145829	284	820	143

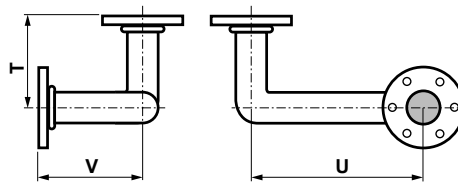

■ GAS FILTER

Code	\varnothing	Dimensions (mm)	
		A	A1
3124111	DN65	290	212
3142088	DN80	320	240
3142205	DN100	380	280
3142206	DN125	380	280

■ TOTAL DIMENSIONS CALCULATION

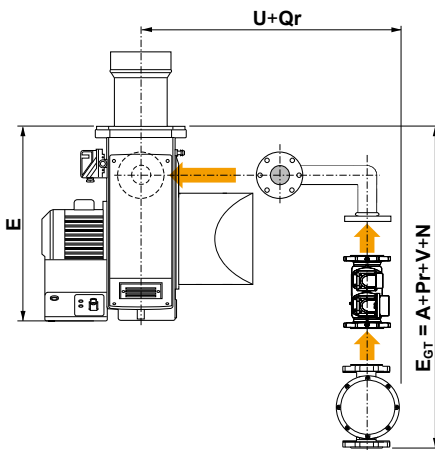

i To calculate the overall dimensions, consider the greater value between E and E_{GT}

OPTIONS**MODULATING
PID CONTROLLER**

Description	Code
Kit RWF50	3143713
Kit RWF55	3147787

i Kit supplied loose; on-board assembly available upon request
See page 257 for more information on RWF kit features

**TEMPERATURE AND
PRESSURE PROBES**

Description	Code
Water probe, temperature range from 0 to 130 °C	3122316
Steam probe 0 ... 2 bar	3124100
Steam probe 0 ... 4 bar	3122317
Steam probe 0 ... 10 bar	3122318
Steam probe 0 ... 16 bar	3122319
Steam probe 0 ... 25 bar	3834314
Steam probe 0 ... 40 bar	3122320
Probe for external temperature from -35° to 50 °C	3122315
Hot air or liquid probe, temperature range from -50° to 400 °C	3122314
Thermocouple J type, temperature up to 750 °C (for RWF55 only)	3146725

**FREQUENCY
CONVERTER**

Description	Code		
IP21 with: • EMC filter • Inductor • Control panel	15 kW	3757059	
	18,5 kW	3757060	
	22 kW	3757061	
	30 kW	3757062	
	37 kW	3757063	
	45 kW	3757064	
	55 kW	3757065	
	IP55 with: • EMC filter • Inductor • Control panel	15 kW	3757072
		18,5 kW	3757073
		22 kW	3757074
30 kW		3757075	
37 kW		3757076	
45 kW		3757077	
55 kW		3757078	

**MAXIMUM GAS
PRESSURE SWITCH**

Description	Output range	Setting range	Code
Kit GPS 150	<15 MW	5 ... 150 mbar	3147771
Kit GPS 500	>15 MW	50 ... 500 mbar	3147772

**GAS GOVERNOR WITH
BUILT-IN FILTER**

Default spring is neutral
for outlet pressure range
10 - 30 mbar

Size	Maximum gas pressure	Code
DN65	1 bar	3141983
DN80	1 bar	3142538
DN100	1 bar	on request
DN125	1 bar	on request

OPTIONS

SPRINGS FOR GAS GOVERNOR

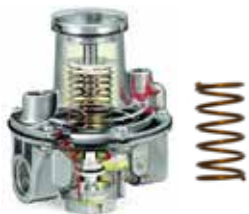

Description	Size	Gas pressure range	Code
Red spring	DN65, DN80	25-80 mbar	3144252
Violet spring		60-120 mbar	3144253
Blue spring		100-220 mbar	3144254
White spring		200-450 mbar	3144255
Red spring	DN100	30-70 mbar	3144256
Violet spring		60-110 mbar	3144257
Brown spring		100-210 mbar	3144258
White spring		200-450 mbar	3144060

GAS FILTER



Size	Code
DN65	3124111
DN80	3142088
DN100	3142205
DN125	3142206

ANTIVIBRATION JOINT



Size	Code
DN65	3142060
DN80	3122328
DN100	3122329
DN125	3142061

MANUAL VALVE



Size	Code
DN65	3142062
DN80	3143730
DN100	3141997
DN125	3141998

MANOMETER + PUSH BUTTON



Description	Pressure range	Code
Gas manometer 1/2"	0...60 mbar	3142056
Gas manometer 1/4"	0...250 mbar	3142055
Gas manometer 1/4"	0...1000 mbar	3142054
Push button 1/2"		3142057
Push button 1/4"		3142058

OPTIONS

FREQUENCY CONVERTER ARRANGEMENT

Description	Code
Models BLU .1 prepared to be connected to an external frequency converter	on request
<p>i This variant includes the VSM module to control the frequency converter; a LCM module is required and must be added separately</p>	

LCM MODULE

Description	Code
LCM module mounted in factory for communication via BUS, O ₂ control and frequency converter	3146795

REMOTE SOFTWARE

Description	Code
Kit to connect a PC to the BT300 for its parametrization (LSA100 + USB/CAN + CD-Rom)	3751130

COMMUNICATION MODULES

Description	Code	
Additional module for BT3 (supplied loose)	ModBus/BT3	on request
	Profibus/BT3	on request
	Ethernet/BT3	on request

O₂ TRIM

Flue temp max 300 °C
 Display for O₂ visualization
 The kit includes:

- Lambda transmitter LT3
- Lambda probe LS2
- Probe installation fitting
- Gas extraction device



! For models equipped with BT3 this kit needs a LCM module installed in the burner control panel

Additional LSB modules installed at LT3	GED length	Code
None	150 mm	3759296
	300 mm	3759297
	450 mm	3759298
4x 0/4-20 mA output	150 mm	3759299
	300 mm	3759300
	450 mm	3759301
4x 0/4-20 mA output + 4x digital output	150 mm	3759302
	300 mm	3759303
	450 mm	3759304
Description	Code	
Extension for LS2	5m ready-made cable	3759318
	PCB (probe connection box) ¹	3759319

O₂ AND CO TRIM

Flue temp max 300 °C
 The kit includes:

- Lambda transmitter LT3-F
- Lambda probe KS1D
- Probe installation fitting
- Gas extraction device

! For models equipped with BT3 this kit needs a LCM module installed in the burner control panel

Additional LSB modules installed at LT3-F	GED length	Code
none	150 mm	3759305
	300 mm	3759306
	450 mm	3759307
4x 0/4-20 mA output	150 mm	3759308
	300 mm	3759309
	450 mm	3759310
4x 0/4-20 mA output + 4x digital output	150 mm	3759311
	300 mm	3759312
	450 mm	3759313
Description	Code	
Extension for KS1D	5m ready-made cable	3759318
	PCB (probe connection box) ¹	3759319

! ¹: The PCB is mandatory if the end user chooses to use his own connecting cable and not one of those proposed above
 See page 260 for further information

RANGE OVERVIEW

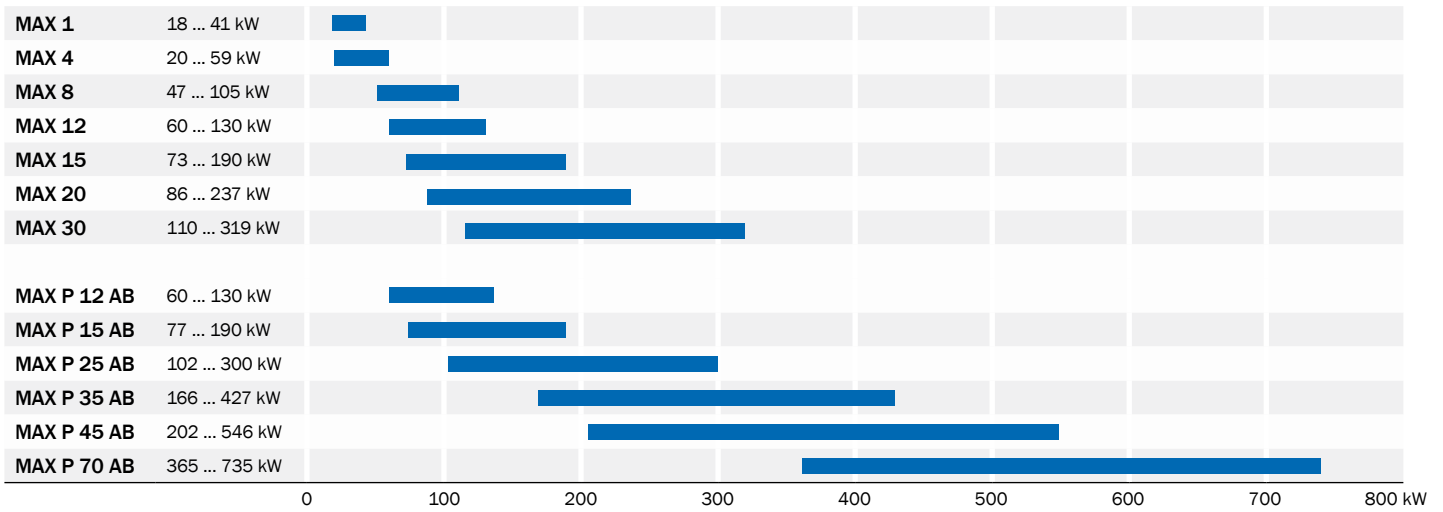

CONFIGURATIONS

MAX range is available in the following operation modes:



MAX 1 ... 30
One stage



MAX P 35 AB ... P 70 AB
Two stages



MAX P 12 AB HS ... P 70 AB HS
Two stages with hydraulic jack

Other available configurations:

- Continuous ventilation versions
- High temperature versions
- Versions with specific pump for light oil with maximum viscosity 5°E at 20°C
- OEM and other special versions on request according to feasibility

■ MAIN FEATURES

- High efficiency fan ventilation system (HPV) allowing easy matching with boilers having high combustion chamber back pressure
- Electrical wiring simple to disassemble for easy maintenance
- Combustion head easy to assemble and adjust
- The hinge flange allows easy access to burner head without losing burner settings (MAX 35, MAX 45 and MAX 70)
- Models from MAX 1 to MAX 12 work with 50-60 Hz electrical frequency

■ FUEL

- Light oil (viscosity from 1,6 cSt to 6 cSt at 20 °C)

■ EMISSIONS

Class	NOx mg/kWh
2	185

All models are in compliance with EN 267 European Standard

■ DIRECTIVES

All products are in accordance with the following directives:

- 2006/42/EC Machinery Directive
- 2014/30/UE EMC Directive
- 2014/35/UE Low Voltage Directive

MAX 4
One stage
Class 2
20 - 59 kW



MAX 12
One stage
Class 2
60 - 130 kW



MAX 15 HT
One stage, High Temperature version
Class 2
73 - 190 kW



MAX P35
AB HS
Two stages with hydraulic system
Class 2
166 - 427 kW



- MAX are monoblock force-draught burners working with light oil and covering an output range from 18 to 735 kW
- All models are equipped with low NOx class 2 ($\text{NOx} \leq 185 \text{ mg/kWh}$) combustion technology in compliance with the EN267 European Standard
- These models are available in three different types of operation:
 - one stage operation (up to MAX 30); MAX 1 and MAX 4 are available with or without pre-heater
 - P AB: two stage operation (MAX P 35 AB ... P 70 AB)
 - P AB HS: two stages with hydraulic system (starting from MAX P 12 AB HS)
- Two different burner controllers are available for one stage models
- As all the Ecoflam burners they are equipped with an adjustable combustion head for easy regulation and matching with different combustion chambers



WORKING DIAGRAM

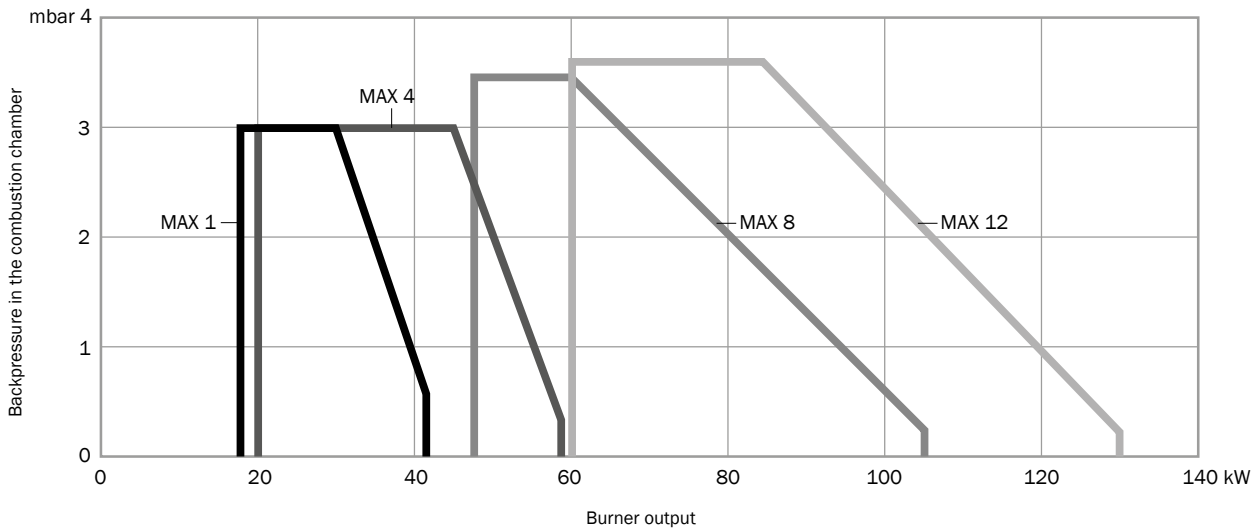

Test conditions conforming to EN267
 Temperature: 20 °C
 Pressure: 1013,5 mbar
 Altitude: 0 m a.s.l.

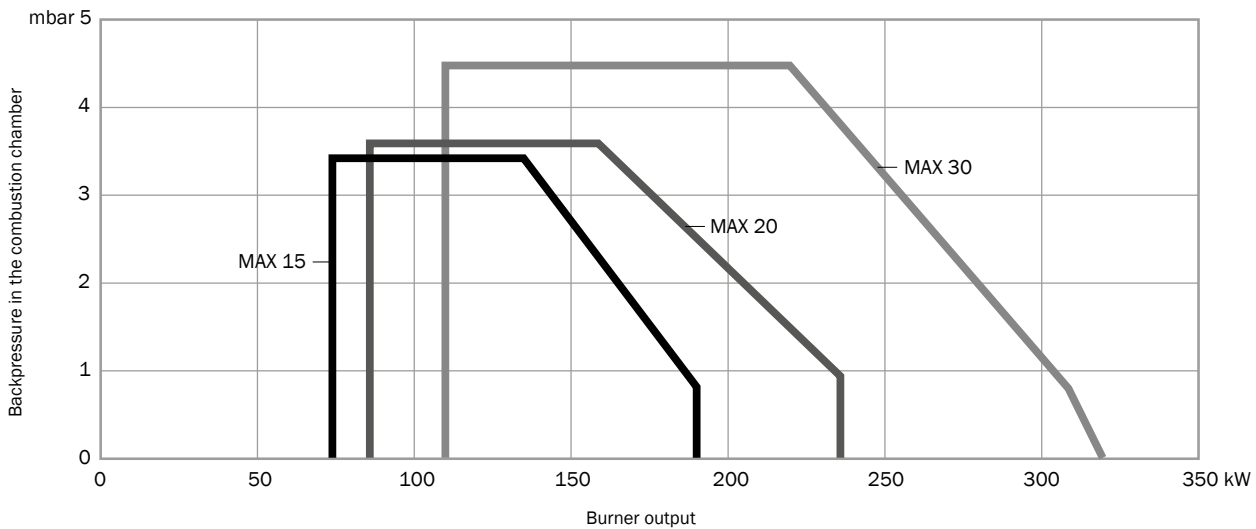

Test conditions conforming to EN267
 Temperature: 20 °C
 Pressure: 1013,5 mbar
 Altitude: 0 m a.s.l.

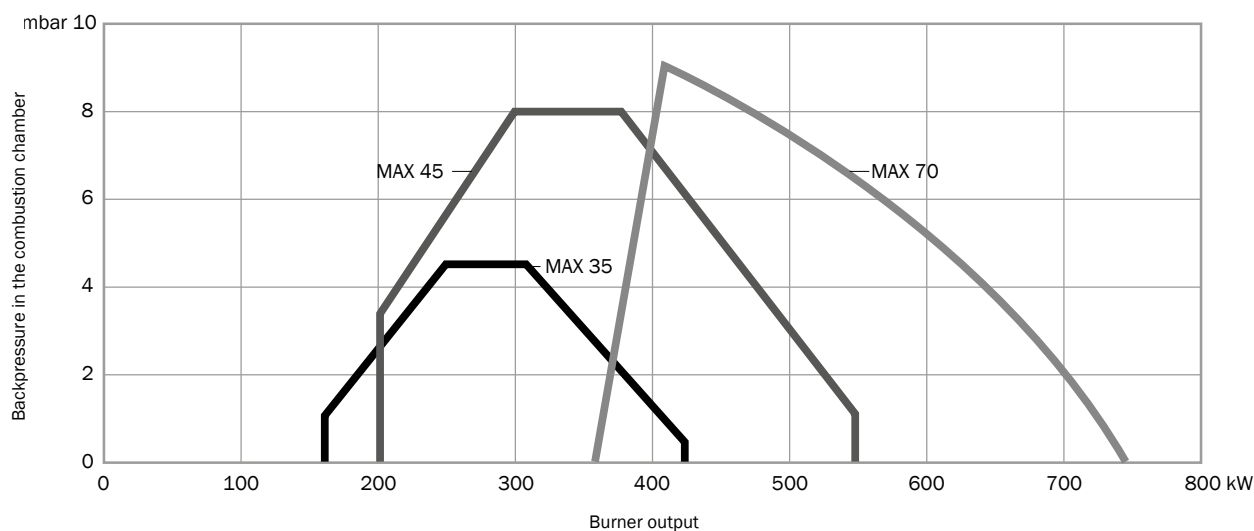
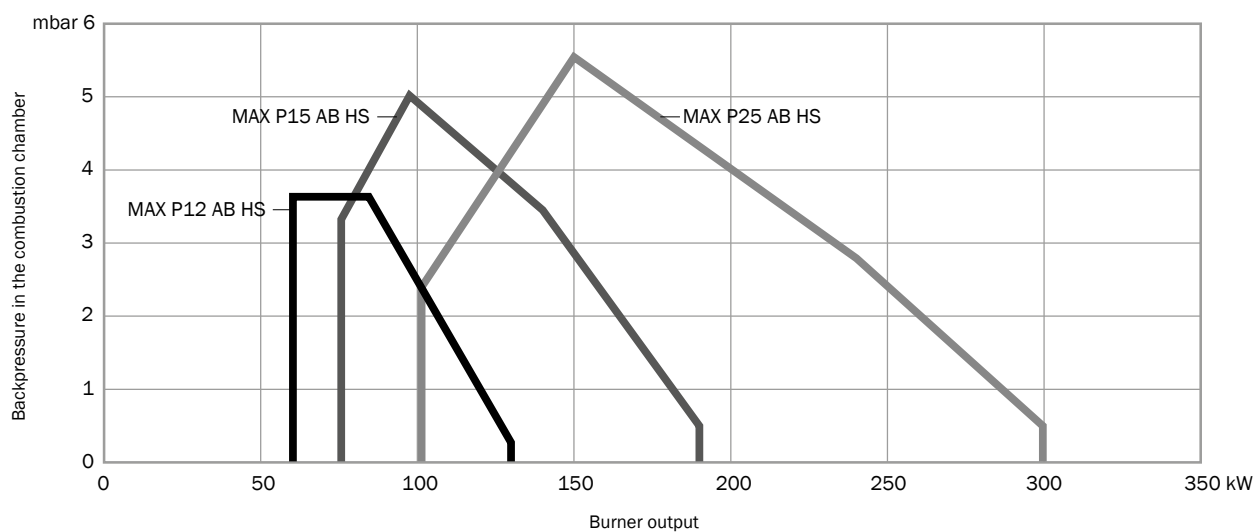

TECHNICAL DATA

Model	Operation	Output (kW)	Flow rate (kg/h)	Control box	Flame detector	Power supply	Motor (W)	Emissions
MAX 1	1 st. R	18 - 41	1,5 - 3,5	TEH111/LM014	FTEB	1/230V/50-60Hz	75	Class 2
MAX 4	1 st. R	20 - 59	1,7 - 5	TEH111/LM014	FTEB	1/230V/50-60Hz	75	Class 2
MAX 8	1 st.	47 - 105	4 - 8,9	TEH111/LM014	FTEB	1/230V/50-60Hz	100	Class 2
MAX 12	1 st. P AB HS	60 - 130	5,1 - 11	LM024	FTEB	1/230V/50-60Hz	130	Class 2
MAX 15	1 st.	73 - 190	6,2 - 16	TEH111/LM014	FTEB	1/230V/50Hz	130	Class 2
	P AB HS	77 - 190	6,5 - 16	LM024	FTEB			
MAX 20	1 st.	86 - 237	7,3 - 20	TEH111/LM014	FTEB	1/230V/50Hz	200	Class 2
MAX 25	P AB HS	102 - 300	8,6 - 25,4	LM024	FTEB	1/230V/50Hz	200	Class 2
MAX 30	1 st.	110 - 319	9,3 - 27	TEH111/LM014	FTEB	1/230V/50Hz	200	Class 2
MAX 35	P AB P AB HS	166 - 427	14 - 36	LM024	FTEB	1/230V/50Hz	370	Class 2
MAX 45	P AB P AB HS	202 - 546	17 - 46	LM024	FTEB	3/230-400V/50Hz	550	Class 2
MAX 70	P AB P AB HS	365 - 735	30,8 - 62	LM024	FTEB	3/230-400V/50Hz	736	Class 2

CODES

■ One stage

Model	Ariston BCU		Siemens BCU	
	TC	TL	TC	TL
MAX 1	3142709	3142710	3120979	3120980
MAX 4	3142714	3142715	3120981	3120982
MAX 8	3142716	3142717	3120983	3120984
MAX 12	3142718	3142719	3120985	3120986
MAX 15	3142729	3142730	3120987	3120988
MAX 20	3142731	3142732	3120989	3120990
MAX 30	3142733	3142734	3120991	3120992

■ R - One stage with pre-heater

Model	Ariston BCU		Siemens BCU	
	TC	TL	TC	TL
MAX 1 R	3142711	3142712	-	-
MAX 4 R	3142720	3142721	-	-

■ P AB HS - Two stages with hydraulic system

Model	Ariston BCU		Siemens BCU	
	TC	TL	TC	TL
MAX P 12 AB HS	-	-	3146905	3146906
MAX P 15 AB HS	-	-	3146907	3146908
MAX P 25 AB HS	-	-	3146909	3146910
MAX P 35 AB HS	-	-	3142301	3142302
MAX P 45 AB HS	-	-	3142305	3142306
MAX P 70 AB HS	-	-	4387036	4387042

■ P AB - Two stages

Model	Ariston BCU		Siemens BCU	
	TC	TL	TC	TL
MAX P 35 AB	-	-	3142943	3142942
MAX P 45 AB	-	-	3142945	3142944
MAX P 70 AB	-	-	on request	on request

OTHER AVAILABLE CONFIGURATIONS

- High temperature (HT)
- Continuous ventilation (CV)
- Post-purge
- Versions with specific pump for light oil with maximum viscosity 5 °E at 20 °C
- 60 Hz (models from MAX 1 to MAX 12 work with 50-60 Hz electrical frequency)
- 110 V
- OEM and other special versions on request according to feasibility



All non-standard configurations are available on request: contact us to know more

OVERALL DIMENSIONS

i Dimensions in mm
 Head length: TC short / TL long

■ MAX 1

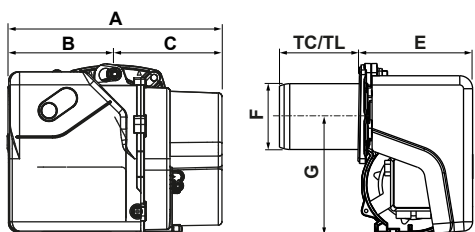

■ MAX 4 - 8 - 12

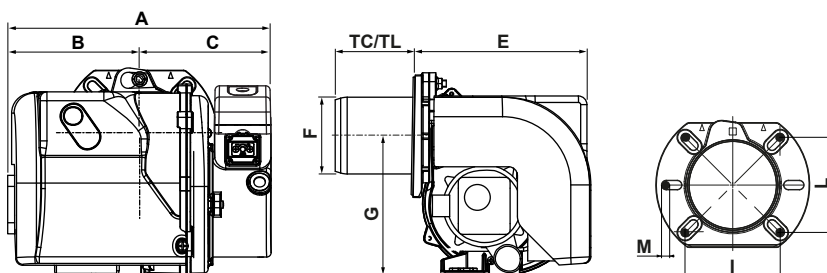

Model	A	B	C	TC	TL	E	F	G	I	L	M
MAX 1	288	143	145	80	140	153	89	160	92/107	92/107	M8
MAX 4	297	149	148	90	145	204	89	160	90/107	90/107	M8
MAX 8	303	155	148	90	145	204	89	160	100/120	100/120	M8
MAX 12	317	169	148	100	170	204	98	160	100/120	100/120	M8

■ MAX 15...30, MAX P 12...25 AB HS

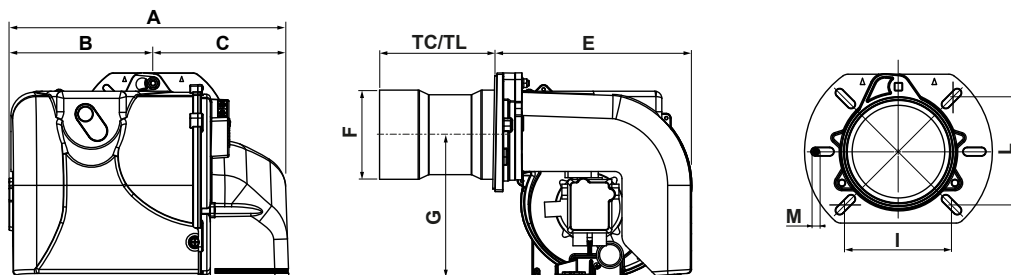

Model	A	B	C	TC	TL	E	F	G	I	L	M
MAX 15	392	202	190	160	260	276	107	201	120/131	120/131	M8
MAX 20	392	202	190	160	260	276	125	201	120/131	120/131	M8
MAX 30	392	202	190	160	260	276	125	201	120/131	120/131	M8
MAX P 12 AB HS	308	169	139	100	155	204	98	160	100/120	100/120	M8
MAX P 15 AB HS	392	202	190	160	260	276	107	201	120/131	120/131	M8
MAX P 25 AB HS	392	202	190	160	260	276	125	201	120/131	120/131	M8

■ MAX GAS P 35...70 AB, MAX P 35...70 AB HS

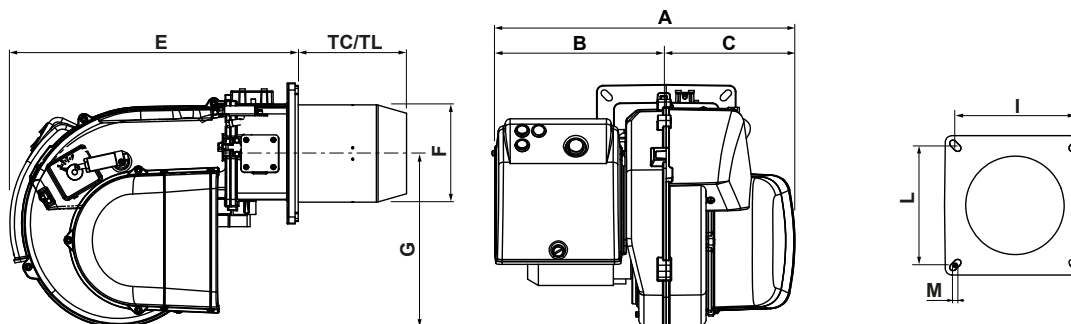

Model	A	B	C	TC	TL	E	F	G	I	L	M
MAX P 35 AB / AB HS	501	294	207	175	365	466	160	280	185/200	185/200	M8
MAX P 45 AB / AB HS	501	294	207	175	365	466	160	280	185/200	185/200	M8
MAX P 70 AB / AB HS	501	294	207	175	365	466	180	280	185/200	185/200	M8

PACKAGING

The burner is delivered in a carton box containing boiler fixing accessories and a bag with technical documentation.

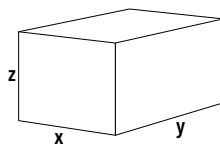

	x	y	z	kg
MAX 1	340	380	290	9
MAX 4	390	420	270	10
MAX 8	390	420	270	10
MAX 12	390	420	270	11
MAX 15	430	610	320	14
MAX 20	430	610	320	15
MAX 25	430	610	320	15
MAX 30	430	610	320	16
MAX 35	500	1020	600	30
MAX 45	500	1020	600	32
MAX 70	500	1020	600	34

Dimensions in **mm**.

Values referred to burners in standard version; the dimensions of the package may vary according to the configuration chosen

OPTIONS**OIL FILTER**

Description	Suitable for	Code
Oil filter 3/8"	MAX 1 ... 30	3142085
Oil filter 3/8"	MAX 35/45	3142089

KIT SNORKEL

Description	Suitable for	Code
Air box with snorkel	MAX 1	65320006
	MAX 4	3146437
	MAX 8/12	3144691
	MAX 15	3147112
	MAX ... AB HS	3145906

RANGE OVERVIEW

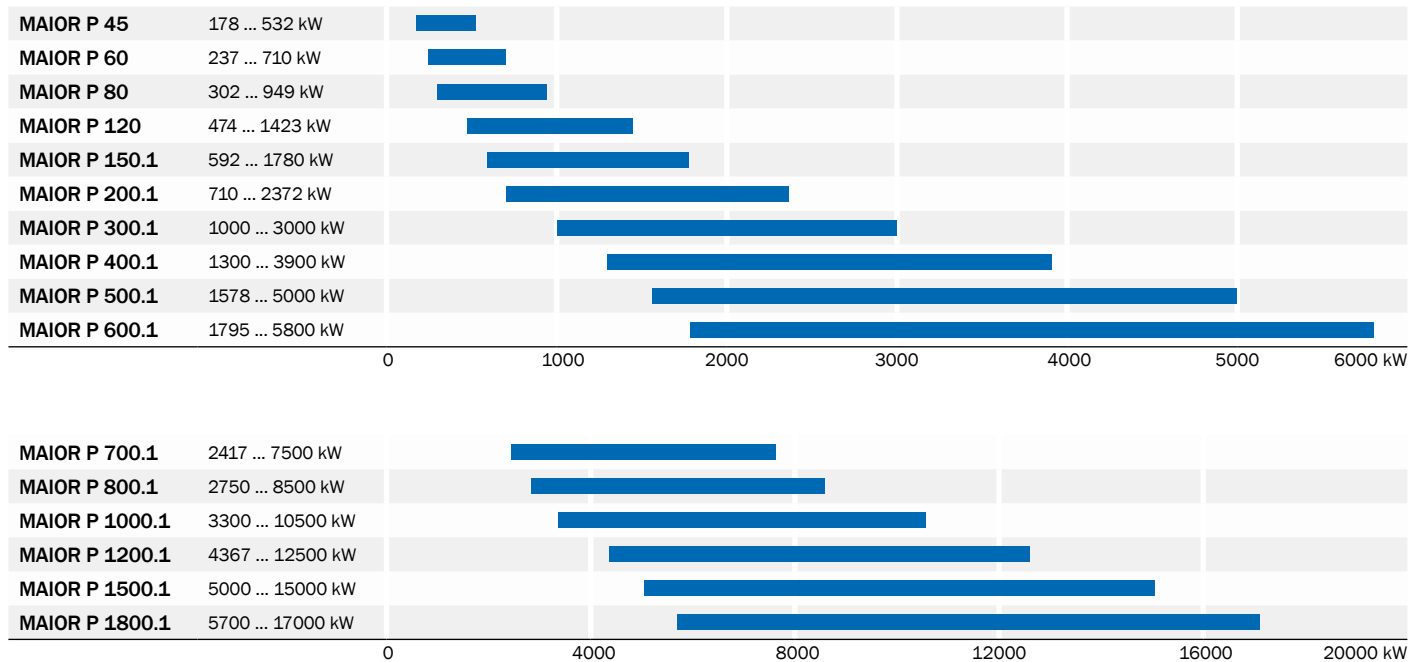

CONFIGURATIONS

MAIOR range is available in the following operation modes:

- MAIOR
P...AB

MAIOR P 60 AB ... P 400.1 AB
 Two stages
- MAIOR
P...AB HS

MAIOR P 60 ... P 400.1 AB HS
 Two stages with hydraulic jack
- MAIOR
P...PR

MAIOR P 45 ... P 1800.1 PR
 Two stages progressive/modulating mechanical
- MAIOR
P...PRE

MAIOR P 45 ... P 1800.1 PRE
 Two stages progressive/modulating electronic

Other available configurations:

- Continuous ventilation versions
- Versions with specific pump for light oil with maximum viscosity 5 °E at 20 °C
- OEM and other special versions on request according to feasibility

■ MAIN FEATURES

- Two stage version with hydraulic jack or electric servomotor up to MAIOR P 400.1
- Progressive mechanical version with flow return nozzle
- Modulating version with PID system controller with digital set point display and real time value
- Version with sliding bars standard for models from MAIOR 700.1 to MAIOR 1200.1
- Adjustable combustion head for easy regulation and matching with different combustion chambers
- Version with fully electronic Burner Management System available for all models on request

■ FUEL

- Light oil (viscosity from 1,6 cSt to 6 cSt at 20 °C)

■ DIRECTIVES

- All products are in accordance with the following directives:
- 2006/42/EC Machinery Directive
 - 2014/30/UE EMC Directive
 - 2014/35/UE Low Voltage Directive

MAIOR P120
AB HS

Two stages with hydraulic system
Class 2
474 - 1423 kW



MAIOR
P200.1 AB

Two stages
Class 2
710 - 2372 kW



MAIOR
P800.1 PR

Two stage progressive mechanical
Class 2
2750 - 8500 kW



MAIOR
P1500.1 PR

Two stage progressive mechanical
Class 2
5000 - 15000 kW



- MAIOR are monoblock force-draught burners working with light oil and covering an output range from 178 to 5800 kW
- These models are available in three different types of operation:
 - P ... AB: two stages (up to MAIOR P 400.1)
 - P ... AB HS: two stages with hydraulic system (up to MAIOR P 400.1)
 - P ... PR: two stage progressive mechanical or modulating with the installation of a power regulator and dedicated probes
 - P ... PRE: two stage progressive electronic versions are available on request
- As all the Ecoflam burners they are equipped with an adjustable combustion head for easy regulation and matching with different combustion chambers
- The structure of the burners allow easy access to the internal components for fast start-up and reduced maintenance time and space



WORKING DIAGRAM

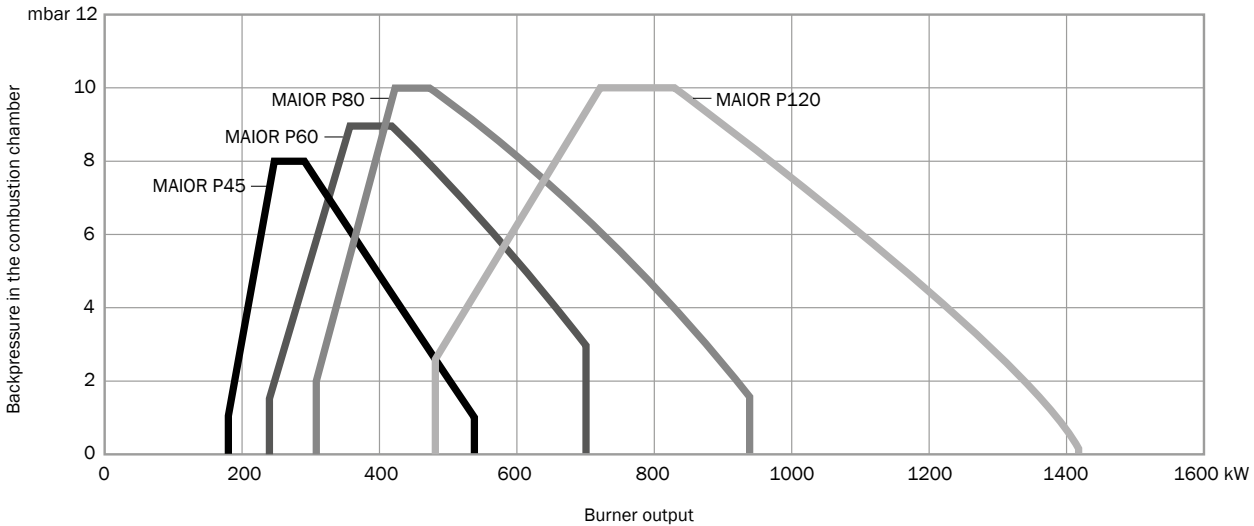

Test conditions conforming to EN267
 Temperature: 20 °C
 Pressure: 1013,5 mbar
 Altitude: 0 m a.s.l.

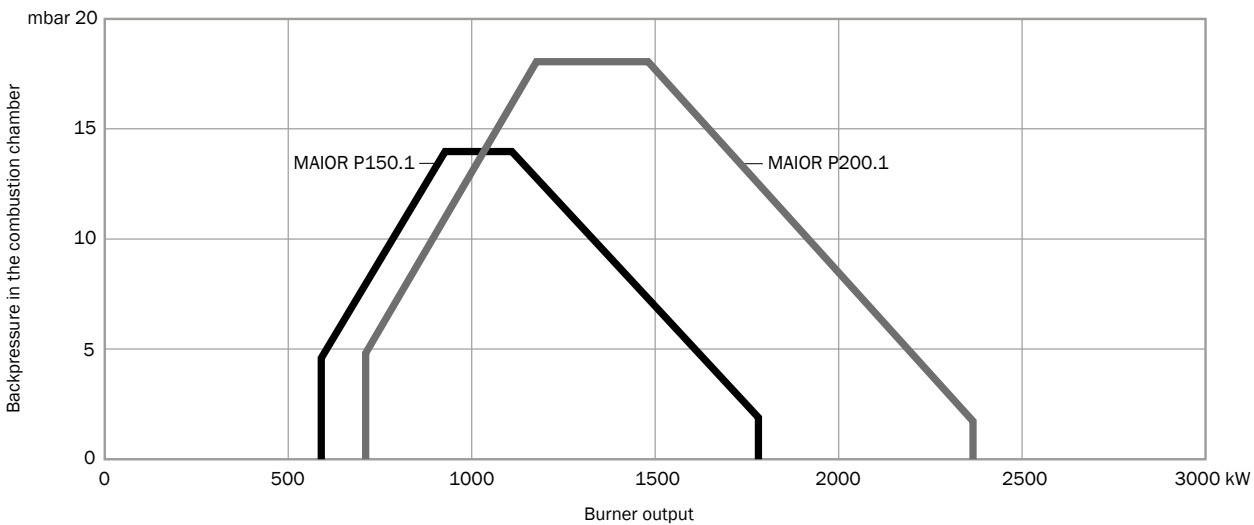

Test conditions conforming to EN267
 Temperature: 20 °C
 Pressure: 1013,5 mbar
 Altitude: 0 m a.s.l.

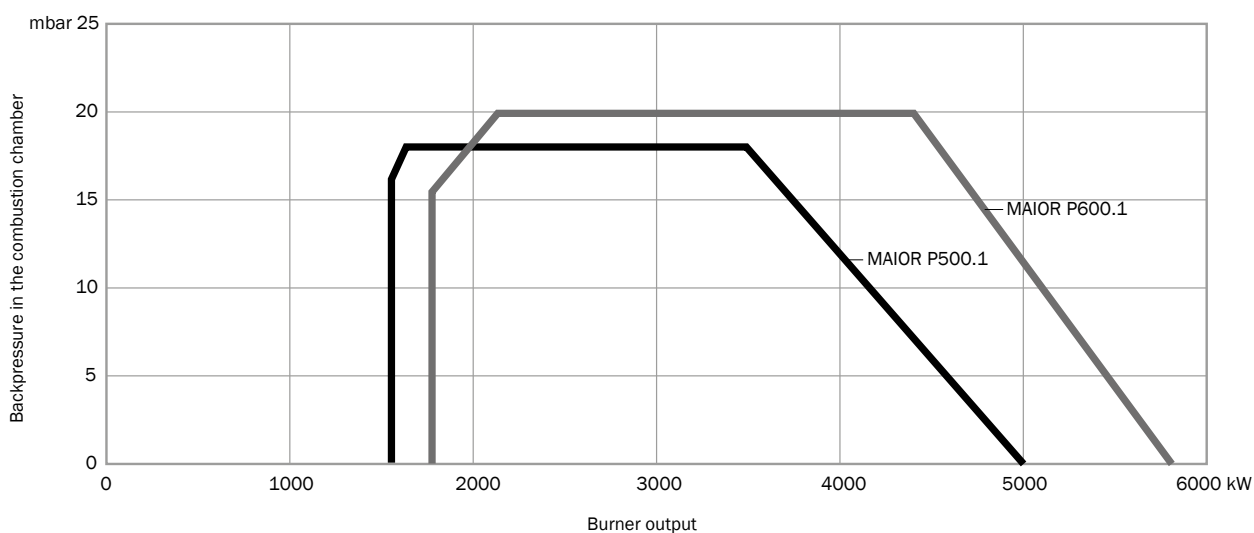
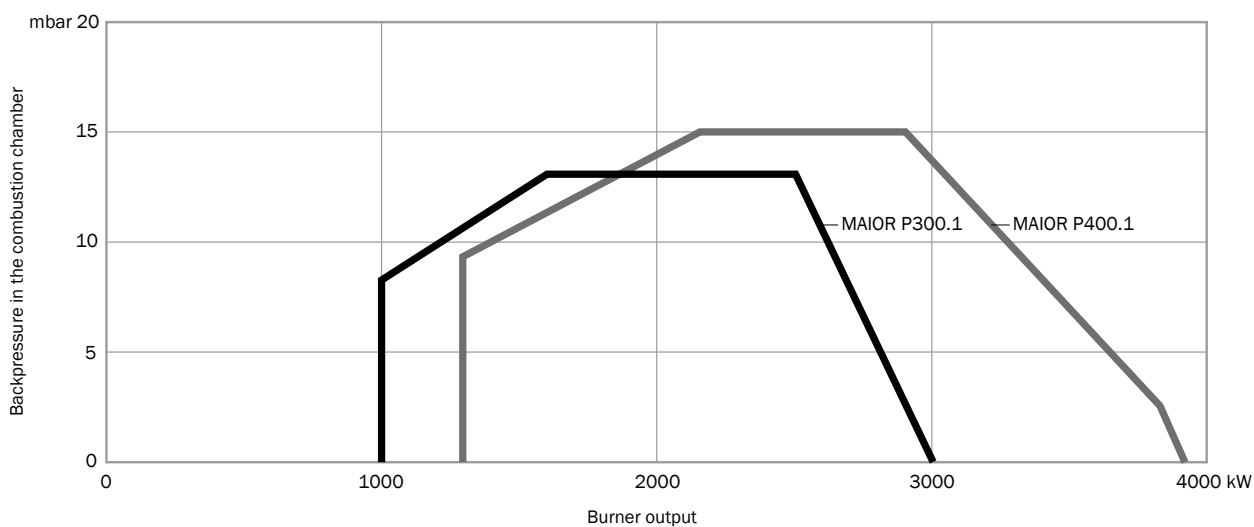
**TECHNICAL DATA**

Model	Operation	Output (kW)	Flow rate (kg/h)	Power supply	Motor (kW)
MAIOR P 45	P PR P PRE	178 - 532	15 - 45	3/230-400V/50Hz	0,55
MAIOR P 60	P AB P AB HS P PR P PRE	237 - 710	20 - 60	3/230-400V/50Hz	1,1
MAIOR P 80	P AB P AB HS P PR P PRE	308 - 949	26 - 80	3/230-400V/50Hz	1,1
MAIOR P 120	P AB P AB HS P PR P PRE	474 - 1423	40 - 120	3/230-400V/50Hz	2,2
MAIOR P 150.1	P AB P AB HS P PR P PRE	592 - 1780	50 - 150	3/230-400V/50Hz	3
MAIOR P 200.1	P AB P AB HS P PR P PRE	710 - 2372	60 - 200	3/230-400V/50Hz	4
MAIOR P 300.1 ¹	P AB P AB HS P PR P PRE	1000 - 3000	85 - 250	3/400V/50Hz	7,5
MAIOR P 400.1 ¹	P AB P AB HS P PR P PRE	1300 - 3900	110 - 330	3/400V/50Hz	9
MAIOR P 500.1 ¹	P PR P PRE	1578 - 5000	134 - 422	3/400V/50Hz	11
MAIOR P 600.1 ¹	P PR P PRE	1795 - 5800	153 - 490	3/400V/50Hz	15



¹: Versions with LME73 on request

CODES

■ P AB - Two stages

Model	TC	TL
MAIOR P 60 AB	3121016	3122265
MAIOR P 80 AB	3121018	3122266
MAIOR P 120 AB	3121020	3122269
MAIOR P 150.1 AB	3121022	3121021
MAIOR P 200.1 AB	3121024	3121023
MAIOR P 300.1 AB	3143731	3143742
MAIOR P 400.1 AB Z3 ¹	314373	3143732

¹ : 2 stages with 3 nozzles

■ P AB HS - Two stages with hydraulic system

Model	TC	TL
MAIOR P 60 AB HS	3121061	3121062
MAIOR P 60 AB HS D ²	3141572	3141571
MAIOR P 80 AB HS	3121063	3121064
MAIOR P 120 AB HS	3121065	3121066
MAIOR P 150.1 AB HS	3121067	3121068
MAIOR P 200.1 AB HS	3121069	3121070
MAIOR P 300.1 AB HS	3143743	3143744
MAIOR P 400.1 AB HS Z3 ¹	3143745	3143746

¹ : 2 stages with 3 nozzles² : equipped with "D" pump

■ P PR - Two stage progressive/modulating mechanical

Model	TC	TL
MAIOR P 45 PR	-	3145193
MAIOR P 60 PR	-	3145194
MAIOR P 80 PR	-	3145195
MAIOR P 120 PR	-	3145196
MAIOR P 150.1 PR	-	3145197
MAIOR P 200.1 PR	-	3145198
MAIOR P 300.1 PR ³	3143734	3143735
MAIOR P 400.1 PR ³	3143736	3143737
MAIOR P 500.1 PR ³	3143738	3143739
MAIOR P 600.1 PR ³	3143740	3143741

³ : Versions with LME73 on request

■ P PRE - Two stage progressive/modulating electronic

Codes available on request.
Contact us in case of order.

OTHER AVAILABLE CONFIGURATIONS

- Continuous ventilation (CV)
- Post-purge
- Versions with specific pump for light oil with maximum viscosity 5 °E at 20 °C
- 60 Hz
- OEM and other special versions on request according to feasibility



All non-standard configurations are available on request: contact us to know more

OVERALL DIMENSIONS

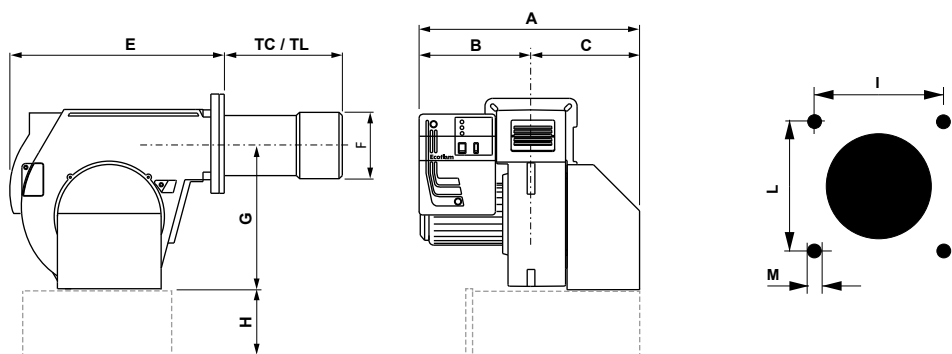

Model	A	B	C	TC	TL	E	F	G	H ¹	I	L	M
MAIOR P 45	590	330	260	225	385	555	160	376	225	190	190	M10
MAIOR P 60	590	330	260	230	390	555	180	376	225	190	190	M10
MAIOR P 80	590	330	260	230	390	555	180	376	225	190	190	M10
MAIOR P 120	690	350	340	220	440	555	190	376	225	190	190	M10

Model	A	B	C	TC	TL	E	F	G	H ¹	I	L	M
MAIOR P 150.1 AB	775	385	390	285	485	660	250	398	283	240	240	M14
MAIOR P 200.1 AB	795	405	390	285	485	660	270	398	283	240	240	M14
MAIOR P 150.1 PR	850	385	465	285	485	660	250	420	680	240	240	M14
MAIOR P 200.1 PR	870	405	465	285	485	660	270	420	680	240	240	M14

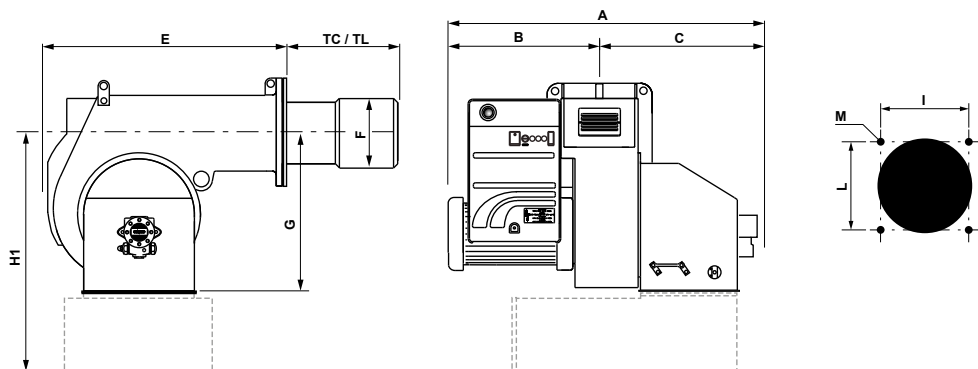

Model	A	B	C	TC	TL	E	F	G	H1 ¹	I	L	M
MAIOR P 300.1	1055	502	553	330	530	810	290	471	746	315	315	M16
MAIOR P 400.1	1100	547	553	345	545	810	320	471	746	315	315	M16
MAIOR P 500.1	1180	535	645	355	555	970	320	570	965	330	330	M16
MAIOR P 600.1	1190	545	645	355	555	970	320	570	965	330	330	M16

i Dimensions in mm
 Head length: TC short / TL long
 1: with silencer (optional)

PACKAGING

The burner is delivered in a carton box containing boiler fixing accessories and a bag with technical documentation.

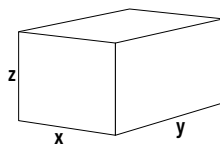

Model	x	y	z	kg
MAIOR P 45	800	1070	590	48
MAIOR P 60	800	1070	590	50
MAIOR P 80	800	1070	590	54
MAIOR P 120	800	1070	590	64
MAIOR P 150.1	930	1300	760	104
MAIOR P 200.1	930	1300	760	110
MAIOR P 300.1	1150	1700	930	230
MAIOR P 400.1	1150	1700	930	240
MAIOR P 500.1	1590	1590	1080	320
MAIOR P 600.1	1590	1590	1080	340

Dimensions in **mm**.

Values referred to burners in standard version; the dimensions of the package may vary according to the configuration chosen

OPTIONS

MODULATING PID CONTROLLER

Description	Code
Kit RWF50	3143713
Kit RWF55	3143714

i Kit supplied loose; on-board assembly available upon request
See page 257 for more information on RWF kit features

OIL FILTER

Description	Suitable for	Code
Oil filter 3/8"	MAIOR P 45/60	3142085

OIL SPILL BACK NOZZLES

! Exclusively for
MAIOR P 45...140

Size (kg/h)	Model	Connection	Code
26	Monarch	Threaded, 9/16"	3142326
33			3143301
37			3142511
39			3142503
49			3142351
50			3142512
62			3143299
71			3142504
76			3142488
90			3145764
97			3141817

OIL SPILL BACK NOZZLES

! All burners except
MAIOR P 45...140

Size (kg/h)	Model	Connection	Code
40	Fluidics W2 50°	Threaded, 7/8"	3145231
50			3145232
60			3142763
70			3145233
80			3145234
90			3145235
100			3142704
115			3142564
130			3142515
145			3142516
160			3142421
180			3142492
200			3142690
225			3142489
250			3142768
275			3142805
300			3142490
330			3142703
360			3142513
400			3142497
450	3142483		
500	3142699		

- MAIOR models from 700.1 to 1800.1 are monoblock force-draught burners working with light oil and covering an output range from 2417 to 17000 kW
- These models are available in two stage progressive mechanical or modulating with the installation of a power regulator and dedicated probes; electronic versions are available on request
- As all the Ecoflam burners they are equipped with an adjustable combustion head for easy regulation and matching with different combustion chambers
- The structure of the burners allow easy access to the internal components for fast start-up and reduced maintenance time and space



WORKING DIAGRAM

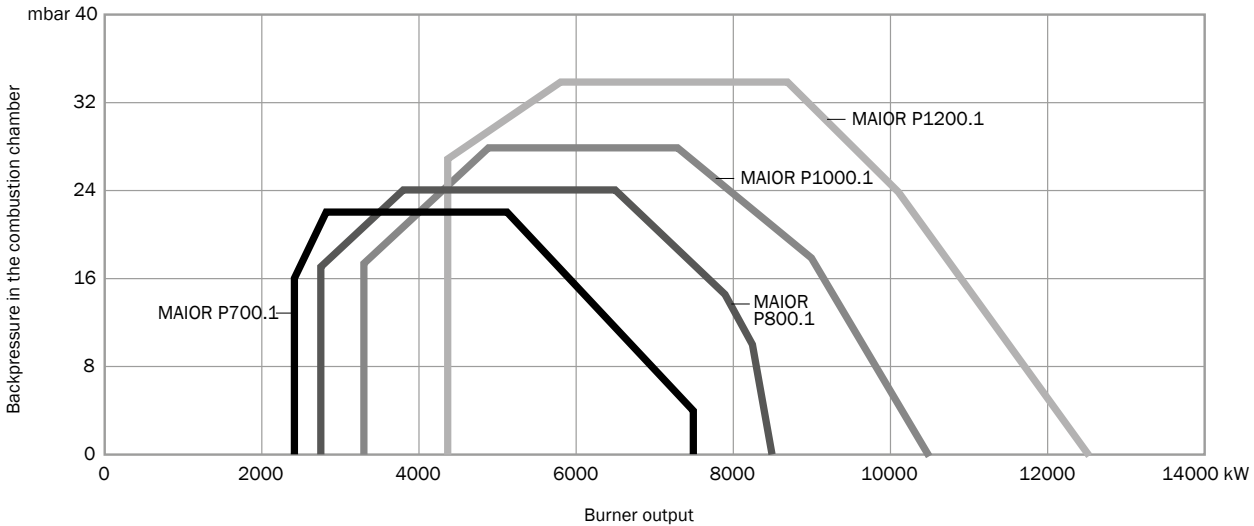

Test conditions conforming to EN267
 Temperature: 20 °C
 Pressure: 1013,5 mbar
 Altitude: 0 m a.s.l.

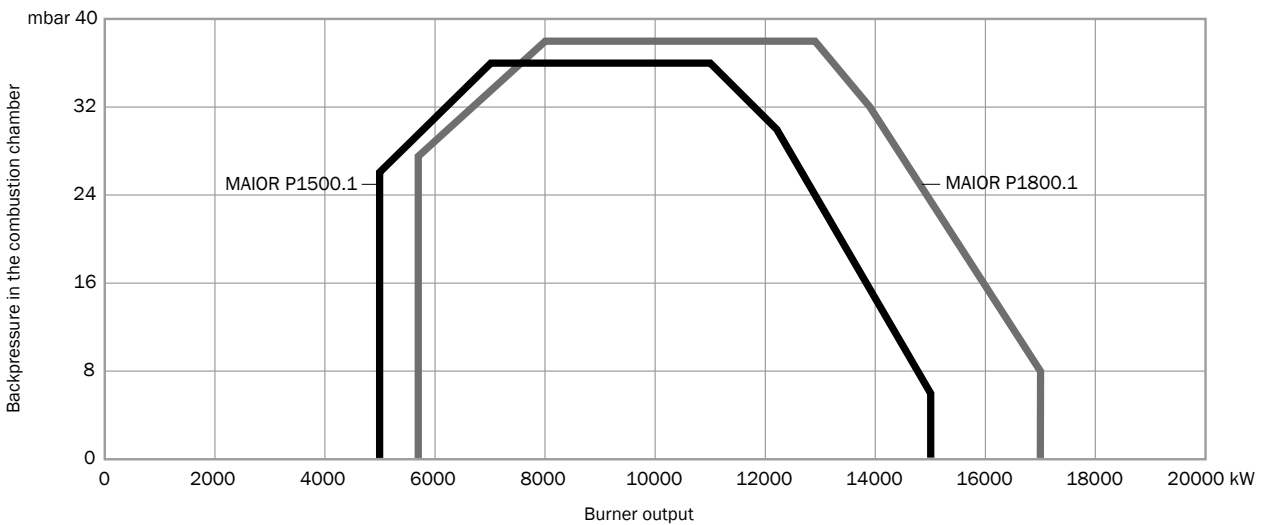

TECHNICAL DATA

Model	Operation	Output (kW)	Flow rate (kg/h)	Control box	Flame detector	Power supply	Motor (kW)
MAIOR P 700.1	PR	2417 - 7500	205 - 634	LAL1.25 ¹	QRB1A	3/400V/50Hz	15
MAIOR P 800.1	PR	2750 - 8500	234 - 718	LAL1.25 ¹	QRB1A	3/400V/50Hz	18,5
MAIOR P 1000.1	PR	3300 - 10500	281 - 887	LAL1.25 ¹	QRB1A	3/400V/50Hz	22
MAIOR P 1200.1	PR	4367 - 12500	371 - 1056	LAL1.25 ¹	QRB1A	3/400V/50Hz	37
MAIOR P 1500.1	PR	5000 - 15000	422 - 1268	LAL1.25 ¹	QRB1A	3/400V/50Hz	45
MAIOR P 1800.1	PR	5700 - 17000	482 - 1437	LAL1.25 ¹	QRB1A	3/400V/50Hz	55

i ¹: Versions with LME73 on request

CODES

■ P PR - Two stage progressive/modulating mechanical

Model	TC	TL
MAIOR P 700.1 PR	on request	on request
MAIOR P 800.1 PR	on request	on request
MAIOR P 1000.1 PR	on request	on request
MAIOR P 1200.1 PR	on request	on request
MAIOR P 1500.1 PR	on request	on request
MAIOR P 1800.1 PR	on request	on request

■ P PRE - Two stage progressive/modulating electronic

Codes available on request.
Contact us in case of order.

OTHER AVAILABLE CONFIGURATIONS

- Continuous ventilation (CV)
- Post-purge
- Versions with specific pump for light oil with maximum viscosity 5 °E at 20 °C
- 60 Hz
- OEM and other special versions on request according to feasibility

i All non-standard configurations are available on request: contact us to know more

OVERALL DIMENSIONS

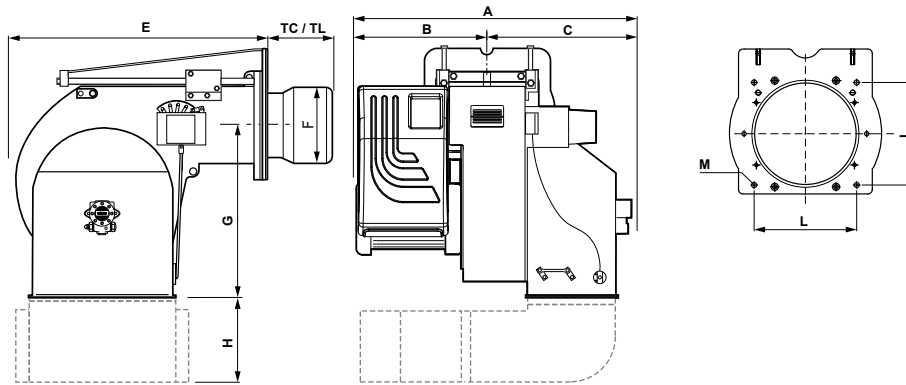

Model	A	B	C	TC	TL	E	F	G	H ¹	I	L	M
MAIOR P 700.1	1340	585	755	457	-	1247	385	800	500	460	460	M20
MAIOR P 800.1	1410	655	755	557	-	1247	465	800	500	460	460	M20
MAIOR P 1000.1	1440	685	755	557	-	1247	465	800	500	460	460	M20
MAIOR P 1200.1	1550	795	755	557	-	1247	465	800	500	460	460	M20

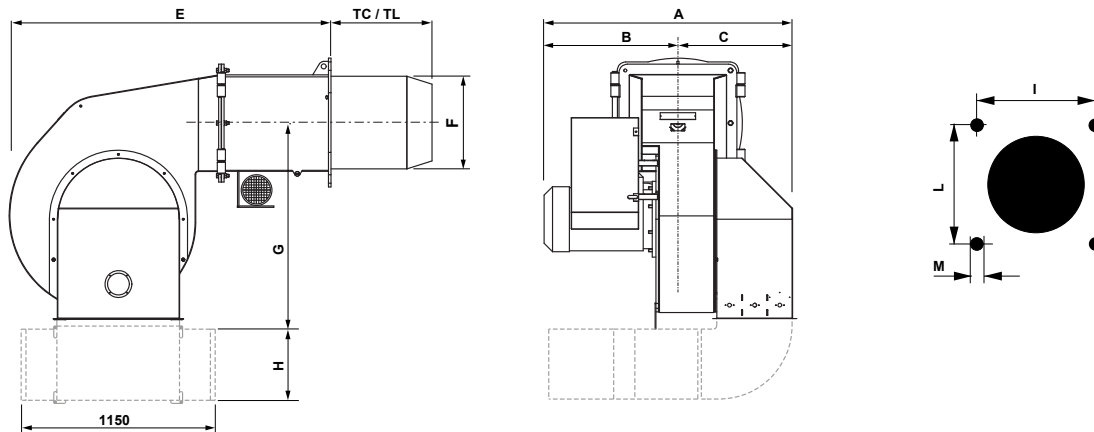

Model	A	B	C	TC	TL	E	F	G	H ¹	I	L	M
MAIOR P 1500.1	1510	800	710	590	-	1910	550	1320	350	620	620	M20
MAIOR P 1800.1	1510	800	710	590	-	1910	550	1320	350	620	620	M20

i Dimensions in mm
Head length: TC short / TL long
¹: with silencer (optional)

PACKAGING

The burner is delivered in a wooden box containing boiler fixing accessories and a bag with technical documentation.

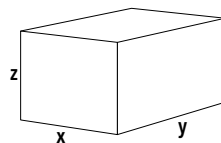

Model	x	y	z	kg
MAIOR P 700.1	1760	2390	1470	920
MAIOR P 800.1	1760	2390	1470	920
MAIOR P 1000.1	1760	2390	1470	935
MAIOR P 1200.1	2080	2780	1940	1260
MAIOR P 1500.1	2080	2780	1940	1400
MAIOR P 1800.1	2080	2780	1940	1400

Dimensions in mm.
Values referred to burners in standard version; the dimensions of the package may vary according to the configuration chosen

OPTIONS

MODULATING PID CONTROLLER



Description	Code
Kit RWF50	3143713
Kit RWF55	3143714

i Kit supplied loose; on-board assembly available upon request
See page 257 for more information on RWF kit features

OIL SPILL BACK NOZZLES

Size (kg/h)	Model	Connection	Code
300	Fluidics W2 50°	Threaded, 7/8"	3142490
330			3142703
360			3142513
400			3142497
450			3142483
500			3142699
600			3142506
650			3142870
700			3145236

RANGE OVERVIEW

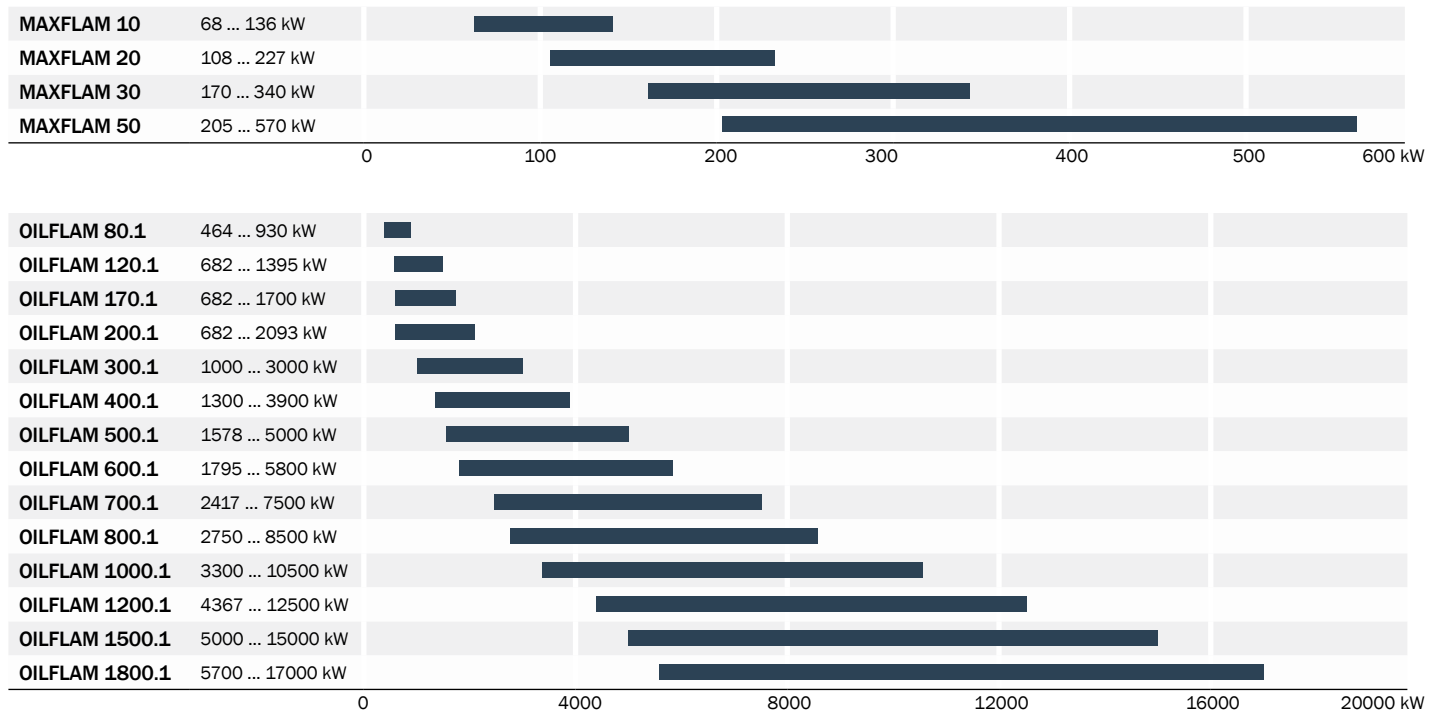

CONFIGURATIONS

MAXFLAM range is available in the following operation modes:

MAXFLAM	MAXFLAM 10 ... 30 One stage
MAXFLAM AB	MAXFLAM 30 ... 50 AB Two stages

OILFLAM range is available in the following operation modes:

OILFLAM AB	OILFLAM 80.1 ... 400.1 AB Two stages
OILFLAM PR	OILFLAM 80.1 ... 1800.1 PR Two stages progressive/modulating mechanical
OILFLAM PRE	OILFLAM 80.1 ... 1800.1 PRE Two stages progressive/modulating electronic

Other available configurations:

- Continuous ventilation versions
- High temperature versions
- High viscosity versions suitable for 118 cSt (15° E) at 80 °C available on request

■ MAIN FEATURES

- All models are suitable to work with heavy oil up to 50 °E at 50 °C
- Two stage version with electric servomotor available up to model OILFLAM 400.1
- Integrated electrical panel complete with pre-heater management system
- Digital thermoregulator integrated on the front panel to grant temperature stability of the fuel (from OILFLAM 300.1)
- Self-cleaning filter installed in the pre-heater in order to keep the nozzle clean from OILFLAM 300.1
- Adjustable combustion head for easy regulation and matching with different combustion chambers
- Heavy oil electric heating system on board
- Ring system for oil preparation can be designed and supply on request
- Version with fully electronic Burner Management System available for all models on request

■ FUEL

Heavy oil (max viscosity 380 cSt (50 °E) at 50 °C)

■ DIRECTIVES

All products are in accordance with the following directives:

- 2006/42/EC Machinery Directive
- 2014/30/UE EMC Directive
- 2014/35/UE Low Voltage Directive

MAXFLAM
20

One stage
108 - 227 kW



MAXFLAM
50 AB

Two stages
205 - 570 kW



OILFLAM
300.1 AB

Two stages
1000 - 3000 kW



OILFLAM
1000.1 PR

Two stage progressive mechanical
3300 - 10500 kW

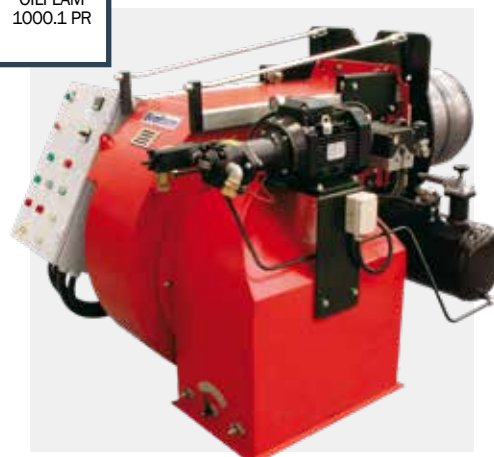

- MAXFLAM range includes monoblock force-draught burners working with heavy oil and covering an output range from 68 to 570 kW
- Standard versions work with heavy oil with maximum viscosity of 380 cSt (50 °E) at 50 °C; high viscosity versions suitable for 118 cSt (15 °E) at 80 °C are available on request
- These models are available in one stage and two stages operation
- All models are equipped with heavy oil electric heating system and integrated electrical panel complete with pre-heater management system
- As all the Ecoflam burners they are equipped with an adjustable combustion head for easy regulation and matching with different combustion chambers



WORKING DIAGRAM

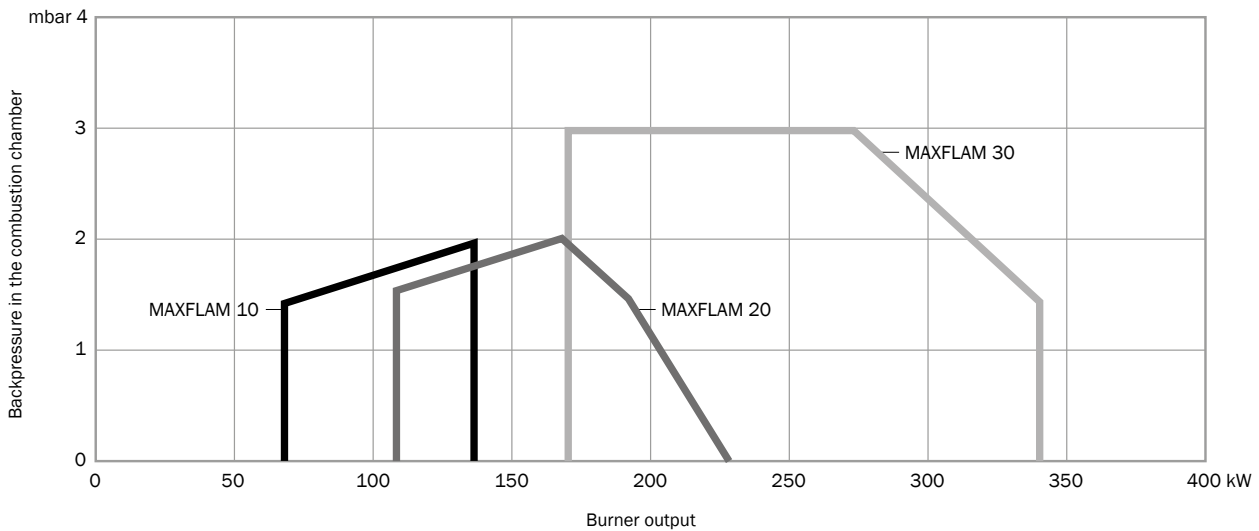

Test conditions conforming to EN267
 Temperature: 20 °C
 Pressure: 1013,5 mbar
 Altitude: 0 m a.s.l.

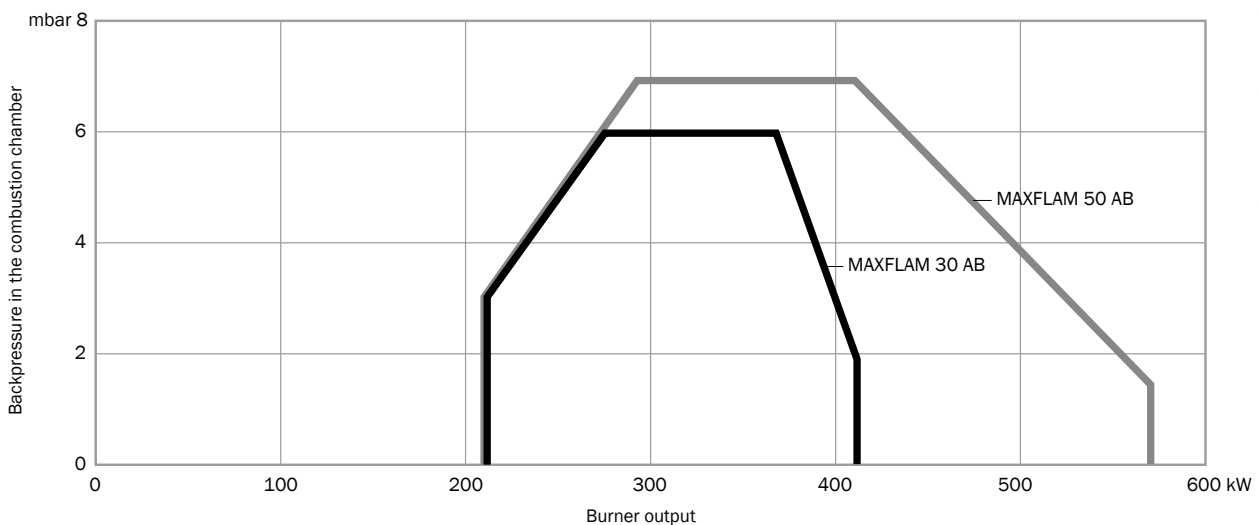

Test conditions conforming to EN267
 Temperature: 20 °C
 Pressure: 1013,5 mbar
 Altitude: 0 m a.s.l.

TECHNICAL DATA

Model	Operation	Output (kW)	Flow rate (kg/h)	Control box	Flame detector	Power supply	Motor (kW)	Resistance (kW)
MAXFLAM 10	1 stage	68 - 136	6 - 12	LMO14	FTEB1	1/230V/50Hz	0,45	1,3
MAXFLAM 20	1 stage	108 - 227	9,5 - 20	LMO14	FTEB1	1/230V/50Hz	0,45	1,95
MAXFLAM 30	1 stage	170 - 340	15 - 30	LMO14	FTEB1	3/230-400V/50Hz	0,74	3,9
	AB	205 - 410	18 - 36	LMO44	FTEB1			
MAXFLAM 50	AB	205 - 570	18 - 50	LMO44	FTEB1	3/230-400V/50Hz	1,1	3,9

CODES

■ One stage

Model	TC	TL
MAXFLAM 10	3143324	3143325
MAXFLAM 20	3143326	3143327
MAXFLAM 30	3143328	3143329

■ AB - Two stages

Model	TC	TL
MAXFLAM 30 AB	3143330	3143331
MAXFLAM 50 AB	3143332	3143333

OTHER AVAILABLE CONFIGURATIONS

- Continuous ventilation (CV)
- Post-purge
- High viscosity version
- 60 Hz
- Other special versions on request according to feasibility

 All non-standard configurations are available on request: contact us to know more

OVERALL DIMENSIONS

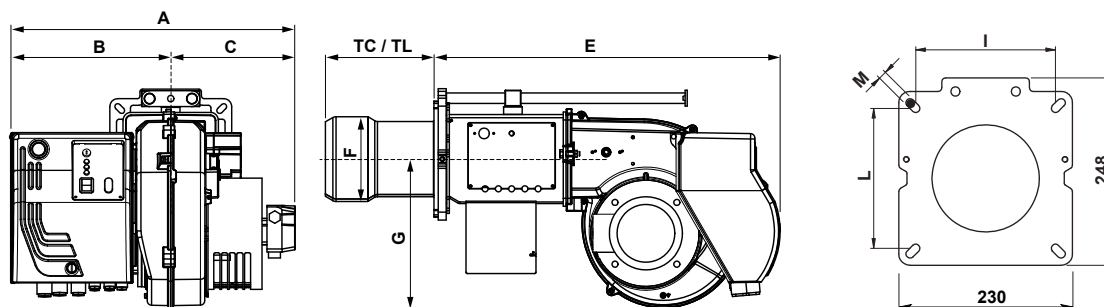

Model	A	B	C	TC	TL	E	F	G	I	L	M
MAXFLAM 10	520	290	230	205	325	535	130	201	160	160	M8
MAXFLAM 20	520	290	230	205	325	535	130	201	160	160	M8
MAXFLAM 30	562	302	260	210	330	653	160	280	185/200	185/200	M10
MAXFLAM 30 AB	562	302	260	205	325	653	170	280	185/200	185/200	M10
MAXFLAM 50 AB	562	302	260	205	325	653	170	280	185/200	185/200	M10

i Dimensions in mm
Head length: TC short / TL long

PACKAGING

The burner is delivered in a carton box containing boiler fixing accessories and a bag with technical documentation.

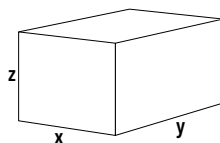

Model	x	y	z	kg
MAXFLAM 10	800	1070	590	50
MAXFLAM 20	800	1070	590	58
MAXFLAM 30	800	1070	590	72
MAXFLAM 50	800	1070	590	74

Dimensions in mm.
Values referred to burners in standard version; the dimensions of the package may vary according to the configuration chosen

OPTIONS

MODULATING PID CONTROLLER



Description	Code
Kit RWF50	3143713
Kit RWF55	3143714

i Kit supplied loose; on-board assembly available upon request
See page 257 for more information on RWF kit features

MAGNETIC + SELF-CLEANING FILTER

Description	Suitable for	Code
Kit 50 kg	MAXFLAM range	3142092

- OILFLAM models from 80.1 to 600.1 are monoblock force-draught burners working with heavy oil and covering an output range from 464 to 5800 kW
- Standard versions work with heavy oil with maximum viscosity of 380 cSt (50 °E) at 50 °C; high viscosity versions suitable for 118 cSt (15 °E) at 80 °C are available on request
- These models are available in two stages operation and two stage progressive or modulating with the installation of a power regulator and dedicated probes (see page 257); electronic versions are available on request
- All models are equipped with heavy oil electric heating system and integrated electrical panel complete with pre-heater management system
- As all the Ecoflam burners they are equipped with an adjustable combustion head for easy regulation and matching with different combustion chambers



WORKING DIAGRAM

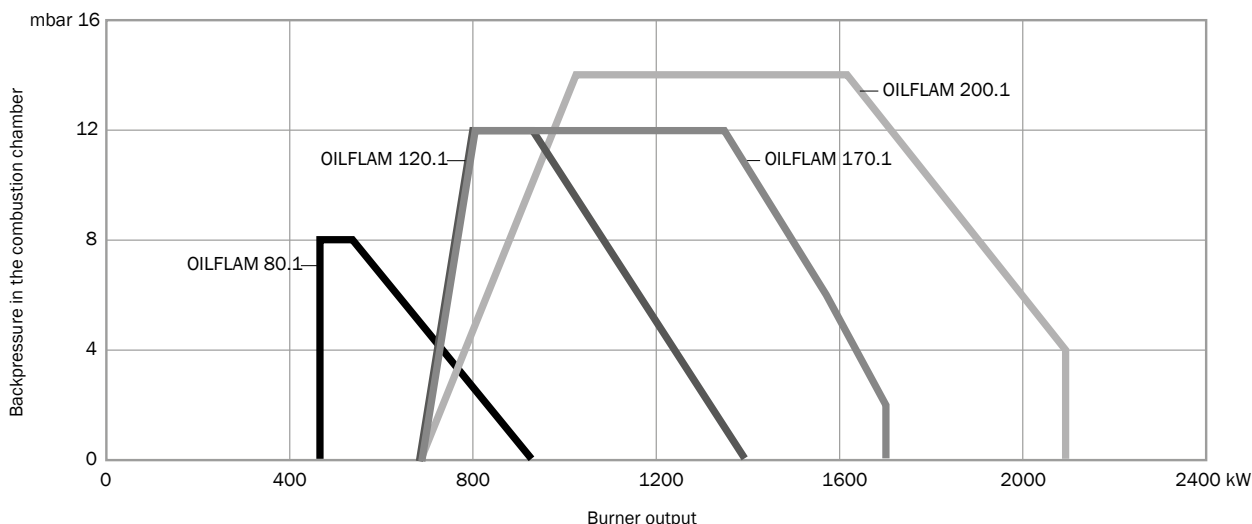

Test conditions conforming to EN267
 Temperature: 20 °C
 Pressure: 1013,5 mbar
 Altitude: 0 m a.s.l.

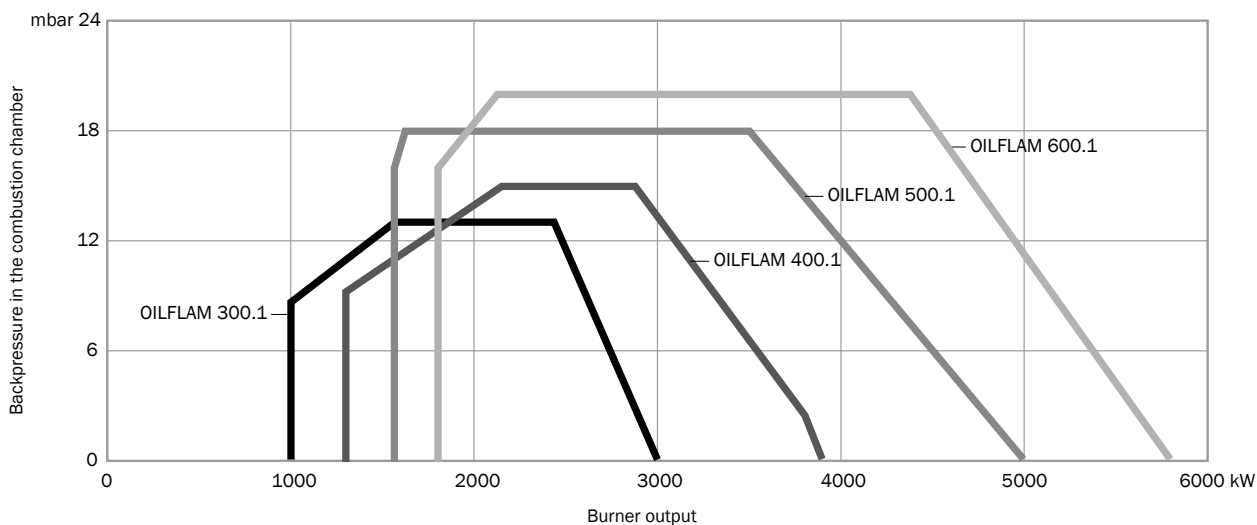

Test conditions conforming to EN267
 Temperature: 20 °C
 Pressure: 1013,5 mbar
 Altitude: 0 m a.s.l.

TECHNICAL DATA

Model	Operation	Output (kW)	Flow rate (kg/h)	Control box	Flame detector	Power supply	Motor (kW)	Resistance (kW)
OILFLAM 80.1	AB PR PRE	464 - 930	41 - 82	LM044	FTEB1	3/230-400V/50Hz	1,5	4,7
OILFLAM 120.1	AB PR PRE	682 - 1395	60 - 122	LM044	FTEB1	3/230-400V/50Hz	2,2	7,1
OILFLAM 170.1	AB PR PRE	682 - 1700	60 - 148	LM044	FTEB1	3/230-400V/50Hz	3	9
OILFLAM 200.1	AB PR PRE	682 - 2093	60 - 184	LM044	FTEB1	3/230-400V/50Hz	4	10,5
OILFLAM 300.1	AB	1000 - 3000	88,5 - 264	LM044	QRB4A	3/230-400V/50Hz	7,5	18
	PR PRE			LAL1.25	QRB1A			
OILFLAM 400.1	AB	1300 - 3900	115 - 343	LM044	QRB4A	3/230-400V/50Hz	9	21
	PR PRE			LAL1.25	QRB1A			
OILFLAM 500.1	PR PRE	1578 - 5000	140 - 440	LAL1.25	QRB1A	3/230-400V/50Hz	11	24
OILFLAM 600.1	PR PRE	1795 - 5800	159 - 510	LAL1.25	QRB1A	3/230-400V/50Hz	15	24

CODES

■ AB - Two stages

Model	TC	TL
OILFLAM 80.1 AB	3142604	3142605
OILFLAM 120.1 AB	3142606	3142607
OILFLAM 170.1 AB	3142608	3142609
OILFLAM 200.1 AB	3142610	3142611
OILFLAM 300.1 AB	3143753	3143754
OILFLAM 400.1 AB Z3	3143755	3143756

■ PR - Two stage progressive/modulating mechanical

Model	TC	TL
OILFLAM 80.1 PR	on request	on request
OILFLAM 120.1 PR	on request	on request
OILFLAM 170.1 PR	on request	on request
OILFLAM 200.1 PR	on request	on request
OILFLAM 300.1 PR	3143757	3143758
OILFLAM 400.1 PR	3143759	3143760
OILFLAM 500.1 PR	3143761	3143762
OILFLAM 600.1 PR	3143763	3143764

■ P PRE - Two stage progressive/modulating electronic

Codes available on request.
 Contact us in case of order.

! Nozzle not included in the code of the burner - see page 251

OTHER AVAILABLE CONFIGURATIONS

- Continuous ventilation (CV)
- Post-purge
- High viscosity version
- 60 Hz
- Other special versions on request according to feasibility

i All non-standard configurations are available on request: contact us to know more

OVERALL DIMENSIONS

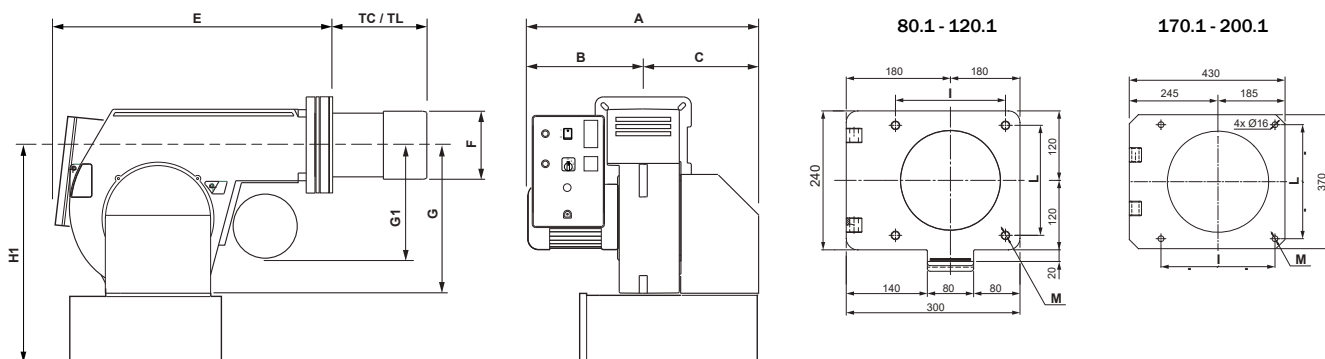

Model	A	B	C	TC	TL	E	F	G	G1	H1 ¹	I	L	M
OILFLAM 80.1	758	388	370	170	310	600	185	390	440	600	190	190	M10
OILFLAM 120.1	758	388	370	170	310	600	185	390	440	600	190	190	M10
OILFLAM 170.1	920	450	470	280	480	710	250	420	390	680	315	315	M14
OILFLAM 200.1	920	450	470	280	480	710	270	420	390	680	315	315	M14

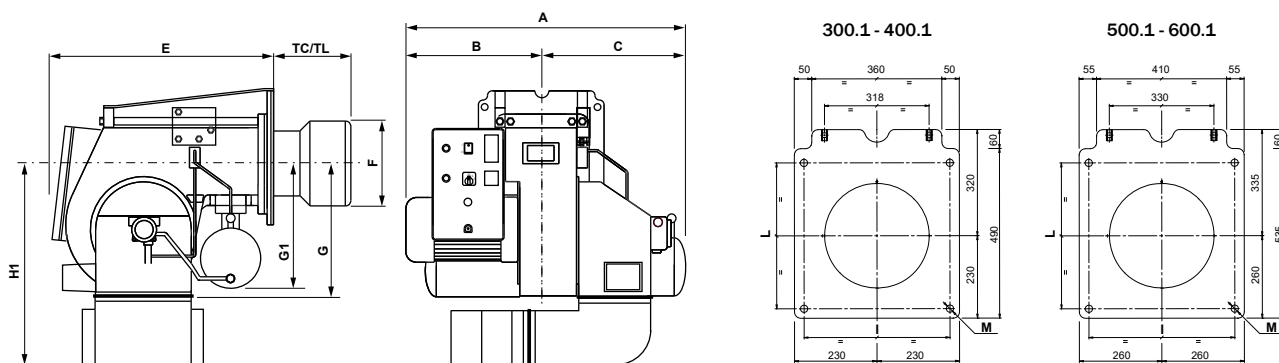

Model	A	B	C	TC	TL	E	F	G	G1	H1 ¹	I	L	M
OILFLAM 300.1	1205	603	602	350	600	925	290	470	430	746	400	400	M16
OILFLAM 400.1	1205	603	602	350	600	925	320	470	430	746	400	400	M16
OILFLAM 500.1	1300	610	690	370	670	990	320	570	480	965	460	460	M16
OILFLAM 600.1	1300	610	690	370	670	990	320	570	480	965	460	460	M16

i Dimensions in mm
 Head length: TC short / TL long
¹: with silencer (optional)

PACKAGING

The burner is delivered in a carton box containing boiler fixing accessories and a bag with technical documentation.

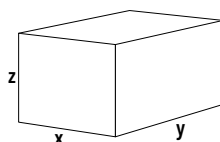

Model	x	y	z	kg
OILFLAM 80.1	800	850	590	123
OILFLAM 120.1	800	850	590	142
OILFLAM 170.1	1150	1380	960	223
OILFLAM 200.1	1150	1380	960	223
OILFLAM 300.1	1590	1590	1080	452
OILFLAM 400.1	1590	1590	1080	476
OILFLAM 500.1	1590	1590	1080	542
OILFLAM 600.1	1590	1590	1080	629

Dimensions in mm.
 Values referred to burners in standard version; the dimensions of the package may vary according to the configuration chosen

OPTIONS**MODULATING
PID CONTROLLER**

Description	Code
Kit RWF50	3143713
Kit RWF55	3143714

i Kit supplied loose; on-board assembly available upon request
See page 257 for more information on RWF kit features

**MAGNETIC +
SELF-CLEANING FILTER**

Description	Suitable for	Code
Kit 250 kg	OILFLAM range	3141965

**SEPARATE
PRE-HEATER**

Description	Suitable for	Code
Pre-heater unit supplied separately	OILFLAM 300.1 ... 600.1	on request

**OIL SPILL BACK
NOZZLES**

Size (kg/h)	Model	Connection	Code
300	Bergonzo B5 AA 45°	Threaded, 7/8"	3142694
400			3142775
425			3142804
450			3142834
500			3142415

! Bergonzo nozzles are recommended for heavy oil burners

- OILFLAM models from 70.1 to 1800.1 are monoblock force-draught burners working with heavy oil and covering an output range from 2417 to 17000 kW
- Standard versions work with heavy oil with maximum viscosity of 380 cSt (50 °E) at 50 °C; high viscosity versions suitable for 118 cSt (15 °E) at 80 °C are available on request
- These models are available in two stage progressive or modulating with the installation of a power regulator and dedicated probes (see page 257); electronic versions are available on request
- All models are equipped with heavy oil electric heating system and integrated electrical panel complete with pre-heater management system
- As all the Ecoflam burners they are equipped with an adjustable combustion head for easy regulation and matching with different combustion chambers



WORKING DIAGRAM

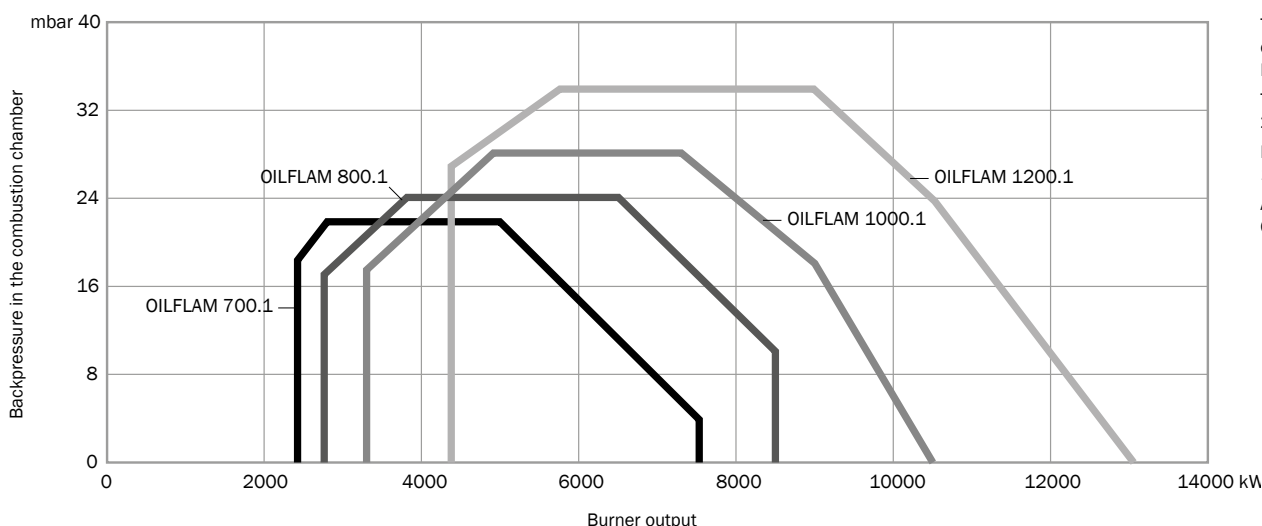

Test conditions conforming to EN267
 Temperature: 20 °C
 Pressure: 1013,5 mbar
 Altitude: 0 m a.s.l.

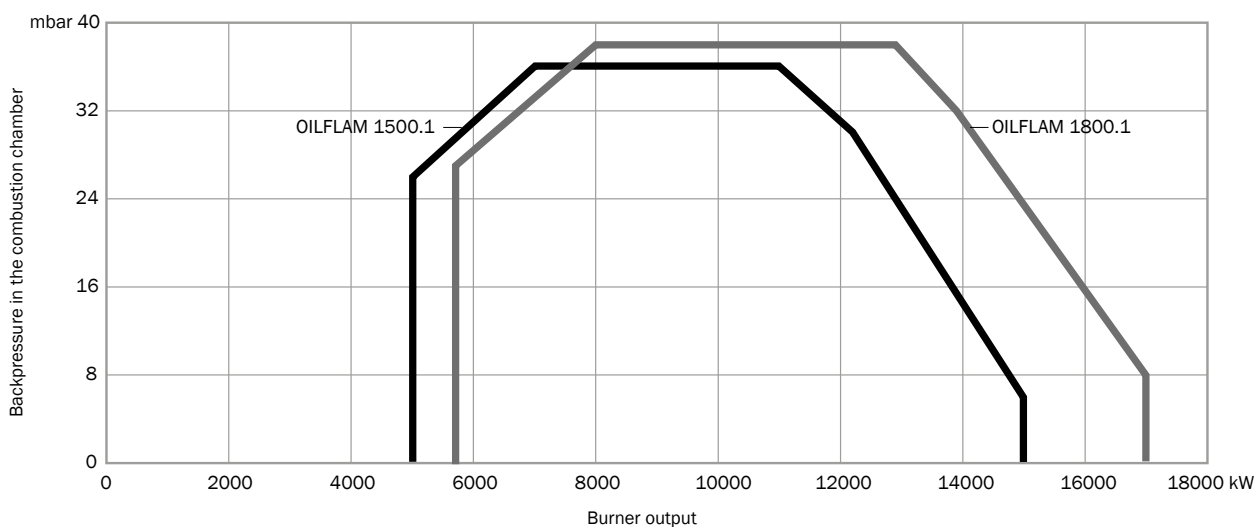

Test conditions conforming to EN267
 Temperature: 20 °C
 Pressure: 1013,5 mbar
 Altitude: 0 m a.s.l.

TECHNICAL DATA

Model	Operation	Output (kW)	Flow rate (kg/h)	Control box	Flame detector	Power supply	Motor (kW)	Resistance (kW)
OILFLAM 700.1	PR PRE	2417 - 7500	214 - 660	LAL2.25	QRB1A	3/400V/50Hz	15	30
OILFLAM 800.1	PR PRE	2750 - 8500	243 - 748	LAL2.25	QRB1A	3/400V/50Hz	18,5	30
OILFLAM 1000.1	PR PRE	3300 - 10500	292 - 924	LAL2.25	QRB1A	3/400V/50Hz	22	44
OILFLAM 1200.1	PR PRE	4367 - 12500	386 - 1099	LAL2.25	QRB1A	3/400V/50Hz	37	2x 30
OILFLAM 1500.1	PR PRE	5000 - 15000	440 - 1319	LAL2.25	QRB1A	3/400V/50Hz	45	75
OILFLAM 1800.1	PR PRE	5700 - 17000	501 - 1495	LAL2.25	QRB1A	3/400V/50Hz	55	75

CODES

■ PR - Two stage progressive/modulating mechanical

Model	TC	TL
OILFLAM 700.1 PR	3143936	on request
OILFLAM 800.1 PR	on request	on request
OILFLAM 1000.1 PR	on request	on request
OILFLAM 1200.1 PR	on request	on request
OILFLAM 1500.1 PR	on request	on request
OILFLAM 1800.1 PR	on request	on request

■ P PRE - Two stage progressive/modulating electronic

Codes available on request.
Contact us in case of order.

 Nozzle not included in the code of the burner - see page 251

OTHER AVAILABLE CONFIGURATIONS

- Continuous ventilation (CV)
- Post-purge
- High viscosity version
- 60 Hz
- Other special versions on request according to feasibility

 All non-standard configurations are available on request: contact us to know more

OVERALL DIMENSIONS

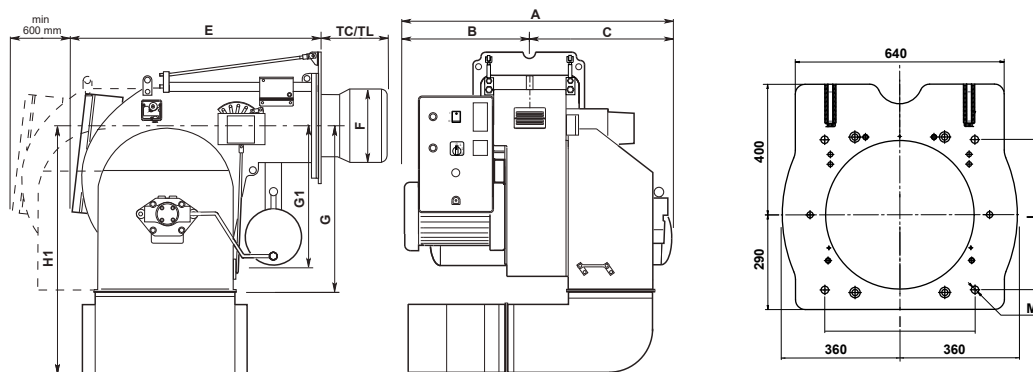

Model	A	B	C	TC	TL	E	F	G	G1	H1 ¹	I	L	M
OILFLAM 700.1	1390	660	730	525	-	1240	385	775	520	1270	460	460	M20
OILFLAM 800.1	1480	660	820	535	-	1240	430	775	520	1270	460	460	M20
OILFLAM 1000.1	1505	685	820	535	-	1240	460	775	520	1270	460	460	M20
OILFLAM 1200.1	1750	800	950	535	-	1410	460	775	900	1270	460	460	M20

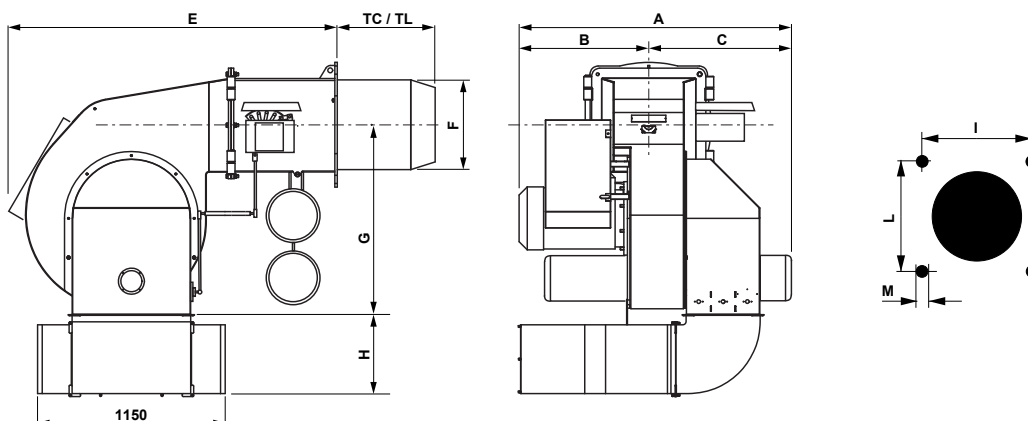

Model	A	B	C	TC	TL	E	F	G	H ¹	I	L	M
OILFLAM 1500.1	1948	860	1088	590	-	1910	550	1167	530	620	620	M20
OILFLAM 1800.1	1948	860	1088	590	-	1910	550	1167	530	620	620	M20

i Dimensions in mm
 Head length: TC short / TL long
¹: with silencer (optional)

PACKAGING

The burner is delivered in a wooden box containing boiler fixing accessories and a bag with technical documentation.

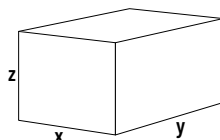

Model	x	y	z	kg
OILFLAM 700.1	1760	2390	1470	964
OILFLAM 800.1	1760	2390	1470	964
OILFLAM 1000.1	1760	2390	1470	1035
OILFLAM 1200.1	2080	2780	1940	1460
OILFLAM 1500.1	2080	2780	1940	1600
OILFLAM 1800.1	2080	2780	1940	1600

Dimensions in mm.
 Values referred to burners in standard version; the dimensions of the package may vary according to the configuration chosen

OPTIONS**MODULATING
PID CONTROLLER**

Description	Code
Kit RWF50	3143713
Kit RWF55	3143714

i Kit supplied loose; on-board assembly available upon request
See page 257 for more information on RWF kit features

**MAGNETIC +
SELF-CLEANING FILTER**

Description	Suitable for	Code
Kit 250 kg	OILFLAM range	3141965

**SEPARATE
PRE-HEATER**

Description	Code
Pre-heater unit supplied separately	on request

**OIL SPILL BACK
NOZZLES**

Size (kg/h)	Model	Connection	Code
300			3142694
400			3142775
425			3142804
450			3142834
500			3142415
600			3141837
650			3144394
700	Bergonzo B5 AA 45°	Threaded, 7/8"	3142948
750			3142491
800			3142833
850			3145237
900			3142510
950			3145238
1000			3142947
1100 - A (for models from 700.1 to 1200.1)			3142949
1000 - B (for models 1500.1 and 1800.1)			3142961
1100			3142769
1200	Bergonzo C5 45°	Threaded, M35x1/2"	3144774
1300			3144490
1400			3142776
1500			3145239

! Bergonzo nozzles are recommended for heavy oil burners

RANGE OVERVIEW

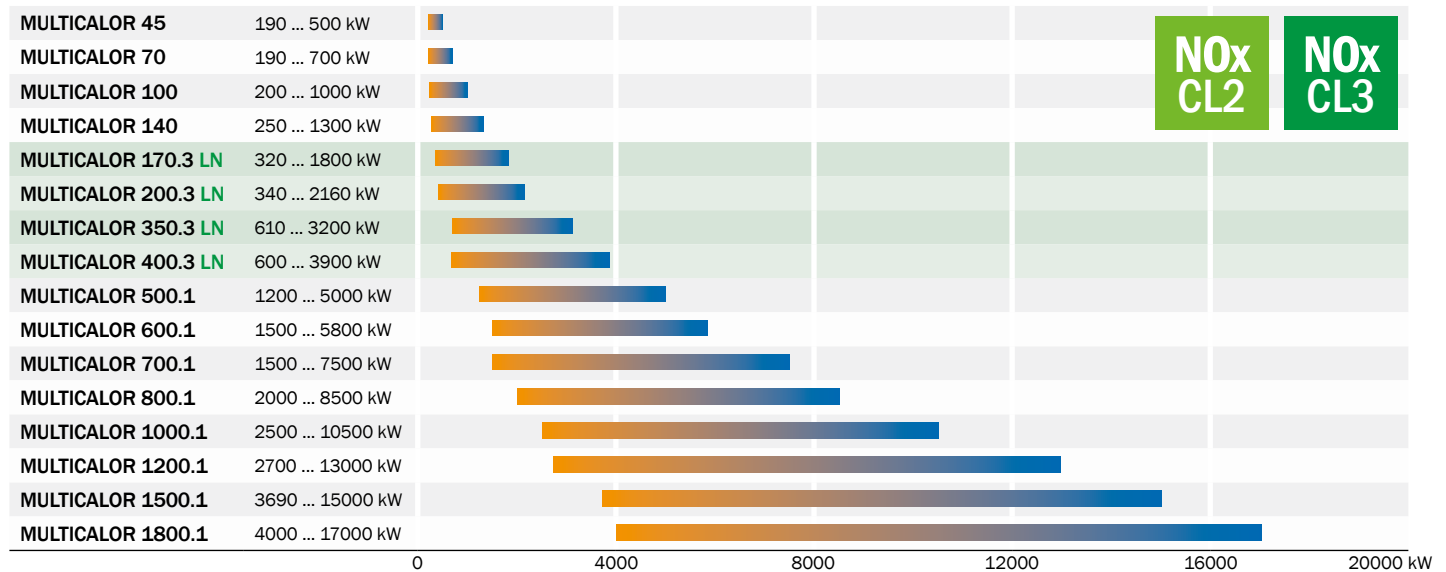

CONFIGURATIONS

MULTICALOR range is available in the following operation modes:

MULTICALOR	MULTICALOR 45 ... 200.1 Two stages in gas and in light oil
MULTICALOR PR/AB	MULTICALOR 70 ... 200.1 PR/AB Two stage progressive/modulating mechanical in gas / two stages in light oil
MULTICALOR PR	MULTICALOR 170.3/400.3 PR and 70 ... 1800.1 PR Two stage progressive/modulating mechanical in gas and in light oil
MULTICALOR PRE	MULTICALOR 170.3/400.3 PRE and 70 ... 1800.1 PRE Two stage progressive/modulating electronic in gas and in light oil

Other available configurations:

- Continuous ventilation versions
- Swirl system for flame geometry customization
- OEM and special versions on request according to feasibility

MAIN FEATURES

- MULTICALOR models from 170.3 to 400.3 are equipped with low emissions combustion head and are classified Low NOx class 3 when operating in gas ($\text{NOx} \leq 80 \text{ mg/kWh}$ according to EN676) and class 2 when operating in light oil ($\text{NOx} \leq 185 \text{ mg/kWh}$ according to EN267)
- Progressive version with electric servomotor and double adjustable mechanical cam that allows air and fuel fine tuning
- Version with fully electronic Burner Management System available for all models
- Adjustable combustion head for easy regulation and matching with different combustion chambers
- Configured and special versions on request according to feasibility

FUEL

- Natural gas (G20, G25 according to EN676)
- LPG
- Light oil (viscosity from 1,6 cSt to 6 cSt at 20 °C)

EMISSIONS

Class	Gas
	NOx mg/kWh
2	120
3	80

All models are in compliance with EN 676 and EN 267 European Standard

DIRECTIVES

All products are built in accordance with the following directives:

- 2006/42/EC Machinery Directive
- 2014/30/UE EMC Directive
- 2014/35/UE Low Voltage Directive
- 2009/142/CEE Gas Appliances Directive

MULTICALOR
170.3 LN PR

Two stage progressive mechanical
in gas and in light oil
320 - 1800 kW



MULTICALOR
500.1 PRE

Two stage progressive electronic
in gas and in light oil
1200 - 5000 kW



MULTICALOR
700.1 PR

Two stage progressive mechanical
in gas and in light oil
1500 - 7500 kW



MULTICALOR
1200.1 PR

Two stage progressive mechanical
in gas and in light oil
2700 - 13000 kW



- MULTICALOR models from 45 to 600.1 are monoblock force-draught burners working with gas or light oil and covering an output range from 190 to 5800 kW
- Models up to MULTICALOR 200.1 are available in different operation modes:
 - two stages in gas and in light oil
 - two stage progressive mechanical or modulating when operating in gas and two stages when operating in light oil
 - two stage progressive mechanical or modulating with the installation of a power regulator and dedicated probes (see page 257)
- The new MULTICALOR models from 170.3 to 400.3 are equipped with low emissions combustion head and are classified Low NO_x class 3 when operating in gas (NO_x ≤ 80 mg/kWh according to EN676) and class 2 when operating in light oil (NO_x ≤ 185 mg/kWh according to EN267)
- Electronic versions are also available: see page 182
- As all the Ecoflam burners they are equipped with an adjustable combustion head for easy regulation and matching with different combustion chambers
- The structure of the burners allow easy access to the internal components for fast start-up and reduced maintenance time and space
- Multiple gas train matching are available according to the inlet gas pressure



WORKING DIAGRAM

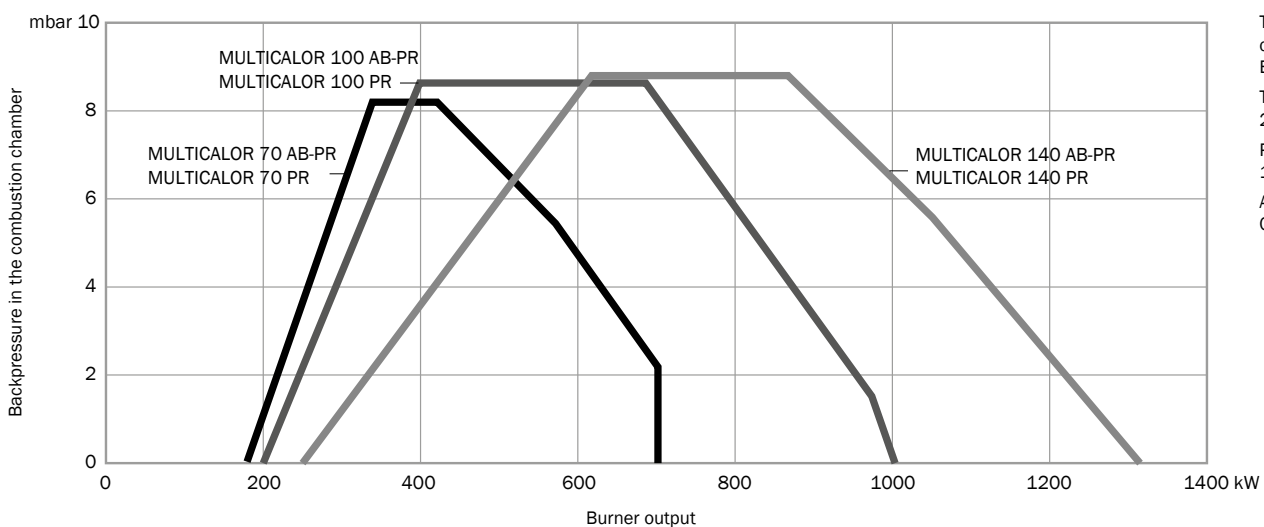
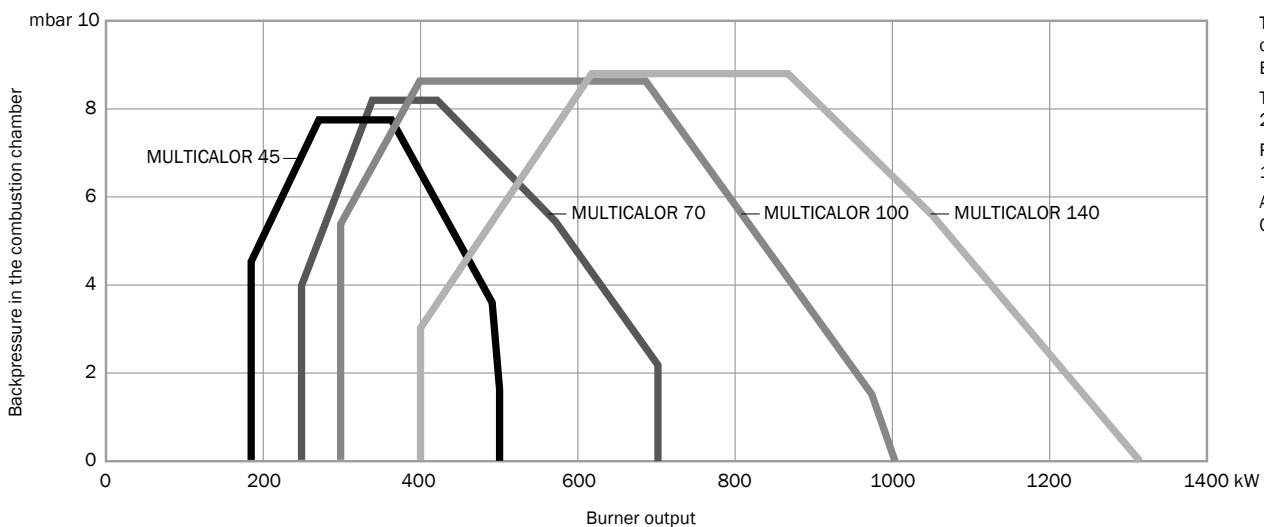

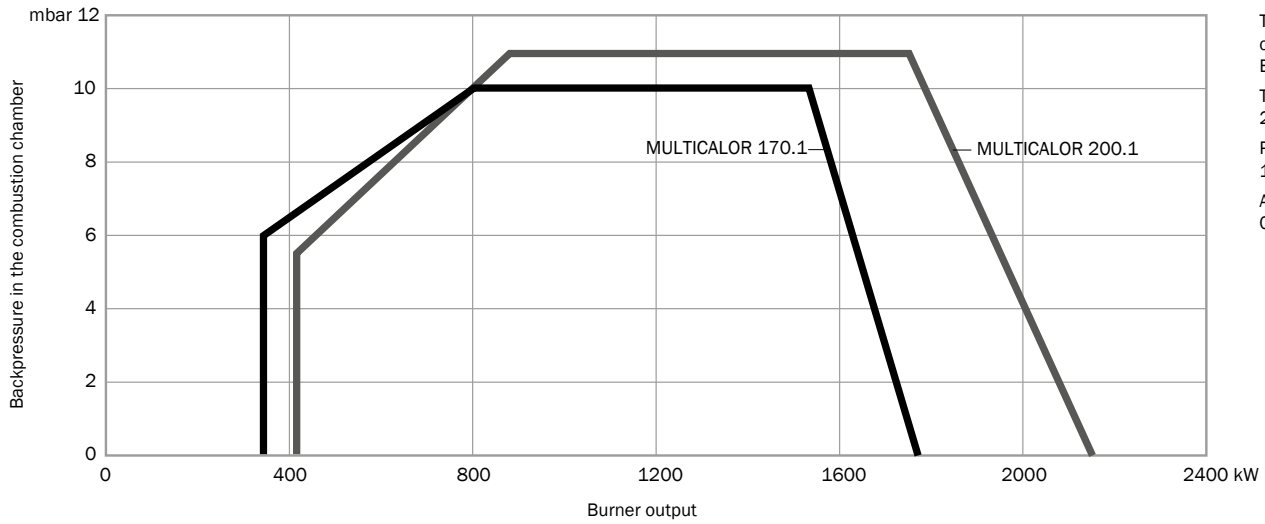

Test conditions conforming to EN676 and EN267
 Temperature: 20 °C
 Pressure: 1013,5 mbar
 Altitude: 0 m a.s.l.

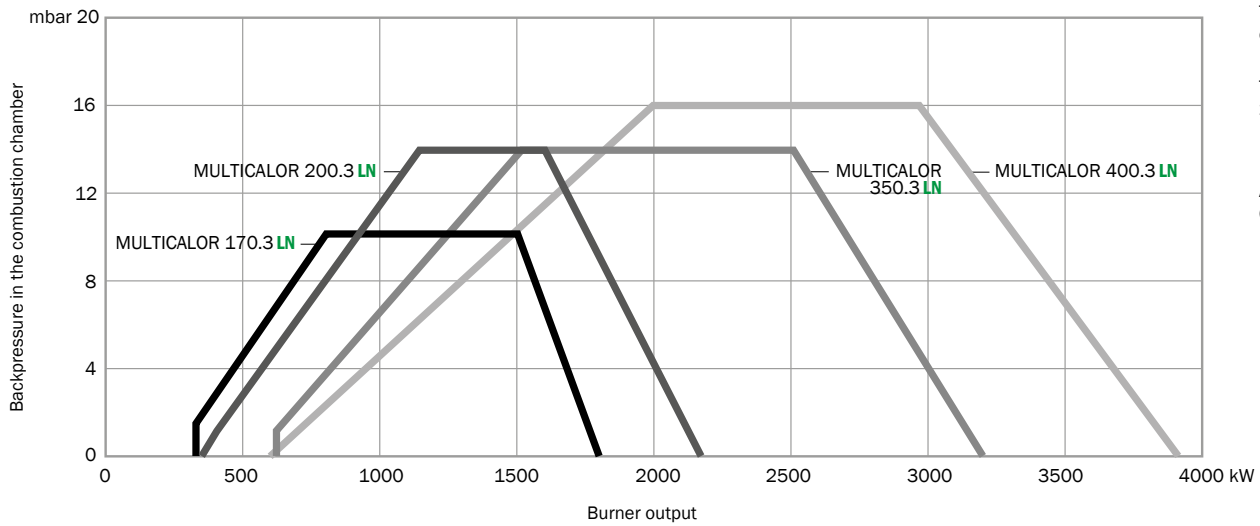

Test conditions conforming to EN676 and EN267
 Temperature: 20 °C
 Pressure: 1013,5 mbar
 Altitude: 0 m a.s.l.

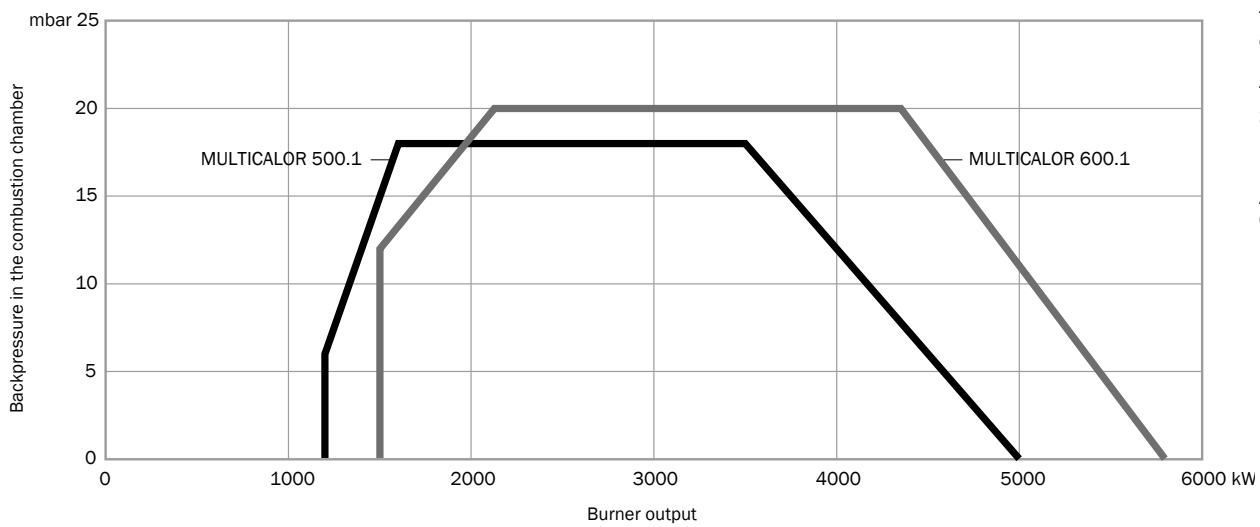

Test conditions conforming to EN676 and EN267
 Temperature: 20 °C
 Pressure: 1013,5 mbar
 Altitude: 0 m a.s.l.

TECHNICAL DATA

Model	Operation	Output (kW)	Flow rate (kg/h)	Control box	Flame detector	Power supply	Motor (kW)	Emissions
MULTICALOR 45	2 stages	190 - 500	16 - 42	LME22	QRA2	3/230-400/50Hz	0,55	Class 2/1
MULTICALOR 70	2 stages	250 - 700	21 - 59	LME22	QRA2	3/230-400/50Hz	1,1	Class 2/1
	PR-AB PR	190 - 700	16 - 59					
MULTICALOR 100	2 stages	300 - 1000	25 - 84	LME22	QRA2	3/230-400/50Hz	1,1	Class 2/1
	PR-AB PR	200 - 1000	17 - 84					
MULTICALOR 140	2 stages	400 - 1300	33 - 110	LME22	QRA2	3/230-400/50Hz	2,2	Class 2/1
	PR-AB PR	250 - 1300	21 - 110					
MULTICALOR 170.1	2 stages PR-AB	342 - 1770	29 - 150	LME22	QRA2	3/230-400/50Hz	3	Class 2/1
MULTICALOR 170.3 LN	PR 72H	320 - 1800	27 - 151	LME73 ¹	QRA2 ²	3/230-400/50Hz	3	Class 3/2
MULTICALOR 200.1	2 stages PR-AB	414 - 2150	35 - 181	LME22	QRA2	3/230-400/50Hz	4	Class 2/1
MULTICALOR 200.3 LN	PR 72H	340 - 2160	29 - 182	LME73 ¹	QRA2 ²	3/230-400/50Hz	4	Class 3/2
MULTICALOR 350.3 LN	PR 72H	610 - 3200	51 - 270	LME73 ¹	QRA2 ²	3/230-400/50Hz	5,5	Class 3/2
MULTICALOR 400.3 LN	PR 72H	600 - 3900	51 - 329	LME73 ¹	QRA2 ²	3/230-400/50Hz	7,5	Class 3/2
MULTICALOR 500.1	PR	1200 - 5000	101 - 423	LME73	QRA2	3/400/50Hz	11	Class 2/1
MULTICALOR 600.1	PR	1500 - 5800	126 - 490	LME73	QRA2	3/400/50Hz	15	Class 2/1

i ¹: LME75 on 72H versions
²: QRA73 on 72H versions

CODES

■ Two stages in gas and in light oil

Model	TC	TL
MULTICALOR 45	3140429	3140428
MULTICALOR 70	3140431	3140430
MULTICALOR 100	3140433	3140432
MULTICALOR 140	3140439	3140438
MULTICALOR 170.1	3142628	3142629
MULTICALOR 200.1	3142630	3142631

■ PR/AB - Two stage progressive/modulating mechanical in gas - Two stages in light oil

Model	TC	TL
MULTICALOR 70 PR-AB	3142632	3142633
MULTICALOR 100 PR-AB	3142634	3142635
MULTICALOR 140 PR-AB	3142636	3142637
MULTICALOR 170.1 PR-AB	3142638	3142639
MULTICALOR 200.1 PR-AB	3142640	3142641

■ PR - Two stage progressive/modulating mechanical in gas and in light oil

Model	TC	TL
MULTICALOR 70 PR	on request	on request
MULTICALOR 100 PR	on request	on request
MULTICALOR 140 PR	on request	on request
MULTICALOR 170.3 LN PR	3149372	3149373
MULTICALOR 200.3 LN PR	3149374	3149375
MULTICALOR 350.3 LN PR	3149378	3149379
MULTICALOR 400.3 LN PR	3149380	3149381
MULTICALOR 500.1 PR	3147260	3147261
MULTICALOR 600.1 PR	3147262	3147263

■ PR 72H - Two stage progressive/modulating mechanical in gas and in light oil, 72-hour continuous operation

Model	TC	TL
MULTICALOR 170.3 LN PR 72H	3149386	3149387
MULTICALOR 200.3 LN PR 72H	3149388	3149389
MULTICALOR 350.3 LN PR 72H	3149392	3149393
MULTICALOR 400.3 LN PR 72H	3149394	3149395

! Nozzle not included in the code of the burner - see page 251

OTHER AVAILABLE CONFIGURATIONS

- Continuous ventilation (CV)
- Post-purge
- 60 Hz
- Special versions on request according to feasibility

i All non-standard configurations are available on request: contact us to know more

OVERALL DIMENSIONS

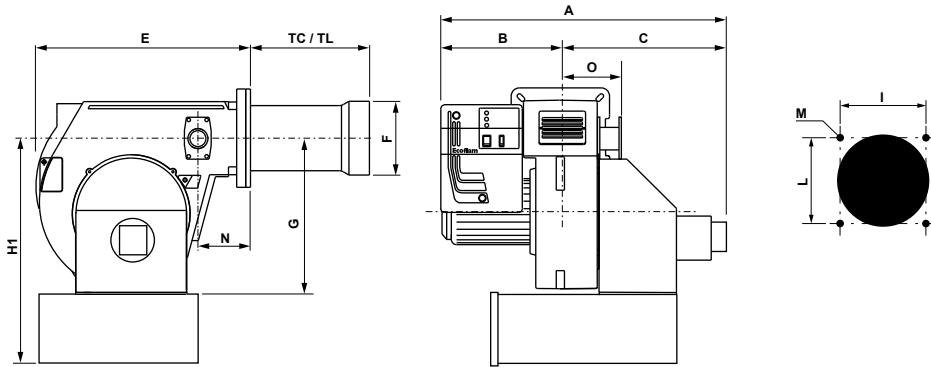

Model	A	B	C	TC	TL	E	F	G	H1 ¹	I	L	M	N	O
MULTICALOR 45	1045	510	535	175	335	555	160	390	600	190	190	M10	140	165
MULTICALOR 70	1045	510	535	175	395	555	180	390	600	190	190	M10	140	165
MULTICALOR 100	1045	510	535	175	395	555	190	390	600	190	190	M10	140	165
MULTICALOR 140	1070	510	560	307	457	555	215	390	600	190	190	M10	140	165
MULTICALOR 70 PR-AB	780	330	450	175	395	555	180	390	600	190	190	M10	140	165
MULTICALOR 100 PR-AB	780	330	450	175	395	555	190	390	600	190	190	M10	140	165
MULTICALOR 140 PR-AB	800	350	450	307	457	555	215	390	600	190	190	M10	140	165
MULTICALOR 70 PR	1045	510	535	175	395	760	180	390	600	190	190	M10	140	165
MULTICALOR 100 PR	1045	510	535	175	395	760	190	390	600	190	190	M10	140	165
MULTICALOR 140 PR	1070	510	560	307	457	760	215	390	600	190	190	M10	140	165

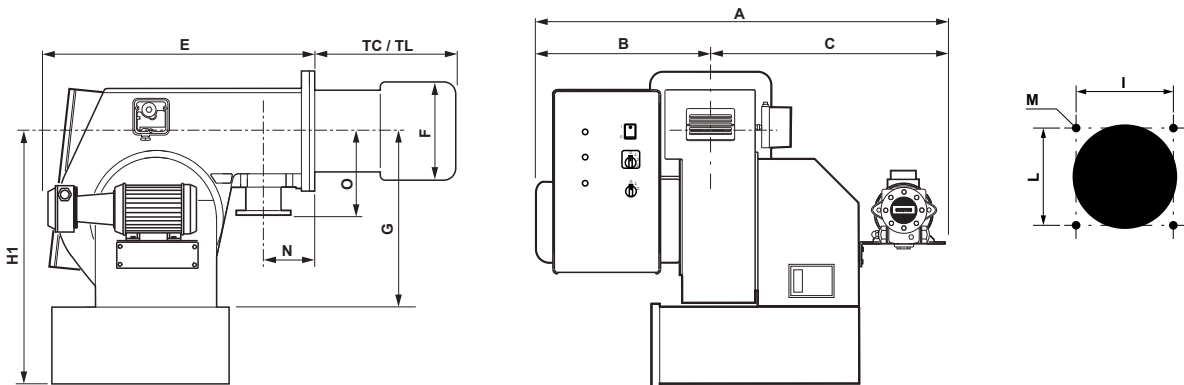

Model	A	B	C	TC	TL	E	F	G	H1 ¹	I	L	M	N	O
MULTICALOR 170.1	965	395	570	290	490	700	250	420	680	240	240	M14	125	250
MULTICALOR 200.1	990	420	570	290	490	700	270	420	680	240	240	M14	125	250
MULTICALOR 170.1 PR-AB	950	400	550	290	490	770	250	420	680	240	240	M14	125	250
MULTICALOR 200.1 PR-AB	950	400	550	290	490	770	270	420	680	240	240	M14	125	250
MULTICALOR 500.1 PR	1200	590	610	355	555	1000	320	570	965	330	330	M16	195	250
MULTICALOR 600.1 PR	1200	590	610	355	555	1000	320	570	965	330	330	M16	195	250

i Dimensions in mm
 Head length: TC short / TL long
¹: with silencer (optional)

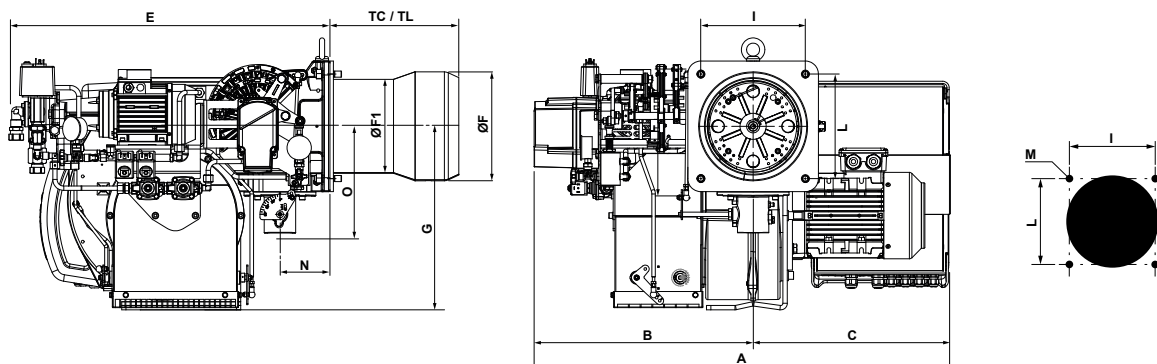
OVERALL DIMENSIONS

Model	A	B	C	TC	TL	E	F	F1	G	I	L	M	N	O
MULTICALOR 170.3 LN PR	898	503	395	288	488	745	250	216	421	240	240	M14	123	245
MULTICALOR 200.3 LN PR	920	503	417	288	488	745	270	216	421	240	240	M14	123	245
MULTICALOR 350.3 LN PR	989	532	457	328	528	778	290	241	471	315	315	M16	195	245
MULTICALOR 400.3 LN PR	989	532	457	344	544	778	320	248	471	315	315	M16	195	245

i Dimensions in mm
Head length: TC short / TL long

PACKAGING

The complete burner with gas train and filter is delivered in a carton box containing boiler fixing accessories and a bag with technical documentation.

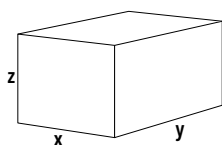

Model	x	y	z	kg
MULTICALOR 45	800	1070	590	54
MULTICALOR 70	800	1070	590	57
MULTICALOR 100	800	1070	590	66
MULTICALOR 140	1150	1380	960	130
MULTICALOR 170.3 LN	1150	1380	960	170
MULTICALOR 200.3 LN	1150	1380	960	190
MULTICALOR 350.3 LN	1590	1590	1080	328
MULTICALOR 400.3 LN	1590	1590	1080	334
MULTICALOR 500.1	1590	1590	1080	420
MULTICALOR 600.1	1590	1590	1080	440

Dimensions in mm.
Values referred to burners in standard version; the dimensions of the package may vary according to the configuration chosen

GAS TRAINS

Model	Pressure (mbar) min - max	Model	Size	Codes	Connection pipe	Filter
for MULTICALOR 45	15 - 360	MB-DLE 415	1"1/2	3141846	-	included
	30 - 360	MB-DLE 412	1"1/4	3141845		included
	50 - 360	MB-DLE 410	1"	3142022		included
	85 - 360	MB-DLE 407	3/4"	3141843		included
for MULTICALOR 70	17 - 360	MB-DLE 420	2"	3141847	-	included
	25 - 360	MB-DLE 415	1"1/2	3141846		included
	75 - 360	MB-DLE 410	1"	3142022		included
for MULTICALOR 100	27 - 360	MB-DLE 420	2"	3141847	-	included
	35 - 360	MB-DLE 415	1"1/2	3141846		included
	75 - 360	MB-DLE 412	1"1/4	3141845		included
for MULTICALOR 140	40 - 360	MB-DLE 420	2"	3141847	-	included
	50 - 360	MB-DLE 415	1"1/2	3141846		included
	100 - 360	MB-DLE 412	1"1/4	3141845		included
	25 - 500	VDG 20.503	2"	3123860		3121384
for MULTICALOR 170.3 LN	60 - 360	MB-DLE 420	2"	4399021	3144686	-
	85 - 360	MB-DLE 415	1"1/2	4399020	3144686	-
	20 - 500	VDG 40.080	DN80	3146006	3148772	3142088
	35 - 500	VDG 40.065	DN65	3146005	3148771	3124111
	45 - 500	VDG 20.5011	2"	4399022	3144686	3121384
for MULTICALOR 200.3 LN	75 - 360	MB-DLE 420	2"	4399021	3144686	-
	100 - 360	MB-DLE 415	1"1/2	4399020	3144686	-
	23 - 500	VDG 40.080	DN80	3146006	3148772	3142088
	35 - 500	VDG 40.065	DN65	3146005	3148771	3124111
	60 - 500	VDG 20.5011	2"	4399022	3144686	3121384
for MULTICALOR 350.3 LN	22 - 500	VDG 40.100	DN100	3146007	3148773	3142205
	35 - 500	VDG 40.080	DN80	3146006	3148772	3142088
	55 - 500	VDG 40.065	DN65	3146005	3148771	3124111
	100 - 500	VDG 20.5011	2"	3146004	3149594	3121384
for MULTICALOR 400.3 LN	30 - 500	VDG 40.100	DN100	3146007	3148768	3142205
	50 - 500	VDG 40.080	DN80	3146006	3148767	3142088
	90 - 500	VDG 40.065	DN65	3146005	3148766	3124111
	170 - 500	VDG 20.5011	2"	3146004	4396173	3121384
for MULTICALOR 500.1	35 - 500	VDG 40.125	DN125	3146008	3145830	3142206
	45 - 500	VDG 40.100	DN100	3146007	3145821	3142205
	75 - 500	VDG 40.080	DN80	3146006	3145864	3142088
	140 - 500	VDG 40.065	DN65	3146005	3145997	3124111
	250 - 500	VDG 20.503	2"	3146004	4396173	3121384
for MULTICALOR 600.1	50 - 500	VDG 40.125	DN125	3146008	3145830	3142206
	60 - 500	VDG 40.100	DN100	3146007	3145821	3142205
	100 - 500	VDG 40.080	DN80	3146006	3145864	3142088
	180 - 500	VDG 40.065	DN65	3146005	3145997	3124111
	340 - 500	VDG 20.503	2"	3146004	4396173	3121384



Default blank spring: head pressure 0...22 mbar; choose and change spring and damping (to be fitted during installation on site)
 For minimum inlet pressures higher than 250 mbar, choose the pressure switch GW500 (to be fitted during installation on site)
 For gas trains in EN676 Configuration a tightness control device must be included over 1200 kW

GAS TRAINS - DIMENSIONS

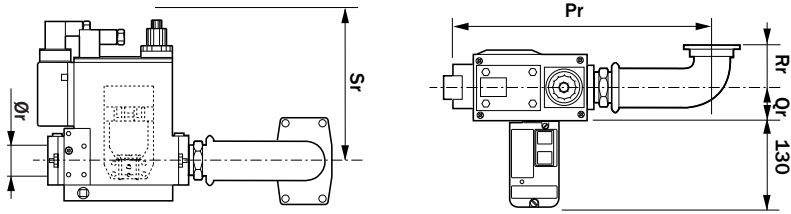

Code	Gas train	Ø	Dimensions (mm)				
			Pr	Qr	Rr	Sr	Ør
3141843	GT-D1-MBDLE407-RP20-BLU/MULTI	Rp3/4"	315	55	85	140	3/4"
3141845	GT-D1-MBDLE412-RP32-BLU/MULTI	Rp1"1/4	330	62	85	160	1"1/4
3141846	GT-D1-MBDLE415-RP40-BLU/MULTI	Rp1"1/2	410	50	85	175	1"1/2
3141847	GT-D1-MBDLE420-RP50-BLU/MULTI	Rp2"	420	50	85	175	2"
3142022	GT-D1-MBDLE410-RP25-BLU/MULTI	Rp1"	330	62	85	160	1"

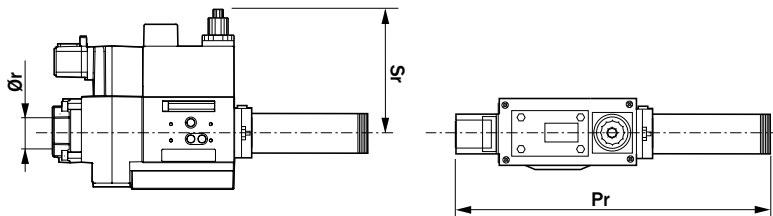

Code	Gas train	Ø	Dimensions (mm)		
			Pr	Sr	Ør
4399020	GT-D1-MBDLE415-RP40-PS3	Rp1"1/2	570	85	1"1/2
4399021	GT-D1-MBDLE420-RP50-PS3	Rp2"	570	109	2"

CONNECTION PIPE

Code	Dimensions (mm)	
	T	U
3144686	100	32

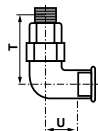

TOTAL DIMENSIONS CALCULATION

MULTICALOR 45 ... 140

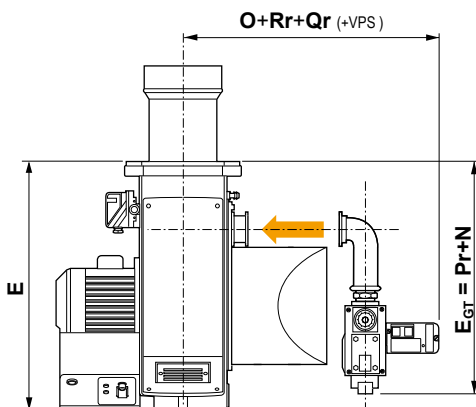

MULTICALOR 170.3 / 200.3

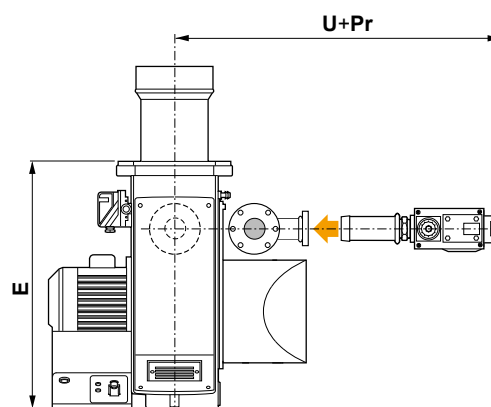
To calculate the overall dimensions, consider the greater value between E and E_{Gr}

GAS TRAINS - DIMENSIONS

■ VGD 20...

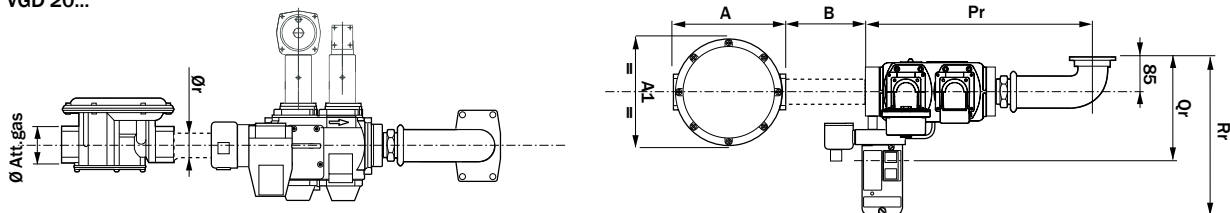

Code	Gas train	\varnothing	Dimensions (mm)			
			Pr	Qr	Rr	\varnothing_r
3123860	GT-S1-VGD20-RP50-BLU/MULTI	Rp2"	450	185	315	2"

■ VGD 20... PS3

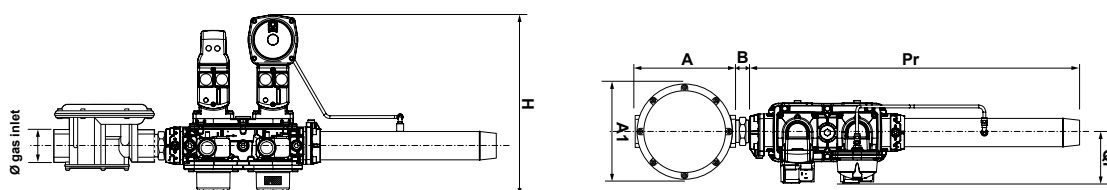

Code	Gas train	\varnothing	Dimensions (mm)			
			Pr	Qr	H	B
4399022	GT-S1-VGD20-RP50-PS3	Rp2"	606	35	385	36

■ VGD 20... PS3

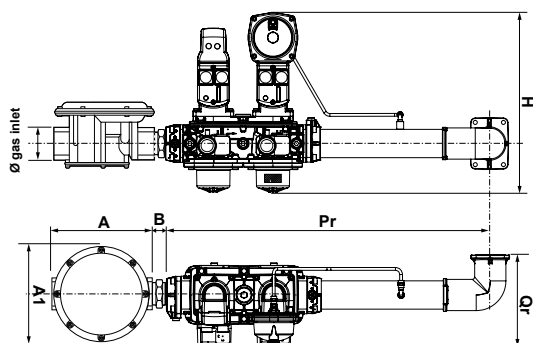

■ VGD 40... PS3

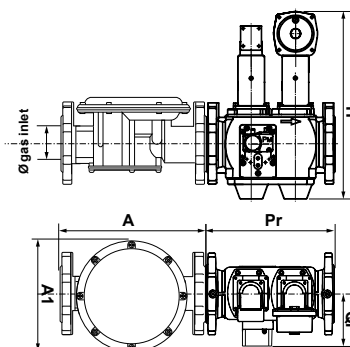

Code	Gas train	\varnothing	Dimensions (mm)			
			Pr	Qr	H	B
3146004	GT-S1-VGD20-RP50-PS3	Rp2"	689	193	382	36
3146005	GT-S1-VGD40-DN65-PS3	DN65	290	127,3	421	-
3146006	GT-S1-VGD40-DN80-PS3	DN80	310	127,3	445	-
3146007	GT-S1-VGD40-DN100-PS3	DN100	350	145,4	476	-
3146008	GT-S1-VGD40-DN125-PS3	DN125	400	158,4	524	-

GAS TRAINS - DIMENSIONS

CONNECTION PIPE

Code	Pic.	Dimensions (mm)		
		T	U	V
4396173	1	85	580	-
3144686	3	100	32	-
3145821	2	122	668	122
3145830	2	156	718	122
3145864	2	122	668	122
3145997	2	122	668	122
3148766	2	122	778	145
3148767	2	145	778	120
3148768	2	145	778	120
3148771	4	100	602	106
3148772	4	100	602	125
3148773	4	100	602	125
3149594	5	100	507	-

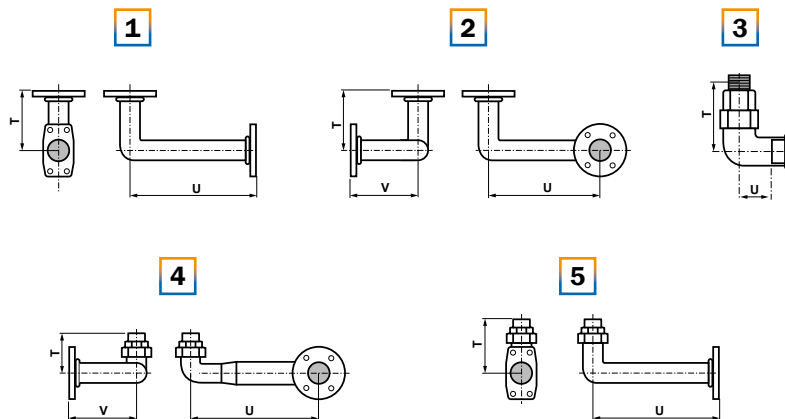

GAS FILTER

Code	Ø	Dimensions (mm)		
		A	A1	B
3121384	Rp2"	186	186	>100
3124111	DN65	290	212	-
3142088	DN80	320	240	-
3142205	DN100	380	280	-
3142206	DN125	380	280	-

GAS TRAINS - DIMENSIONS

TOTAL DIMENSIONS CALCULATION

MULTICALOR 140

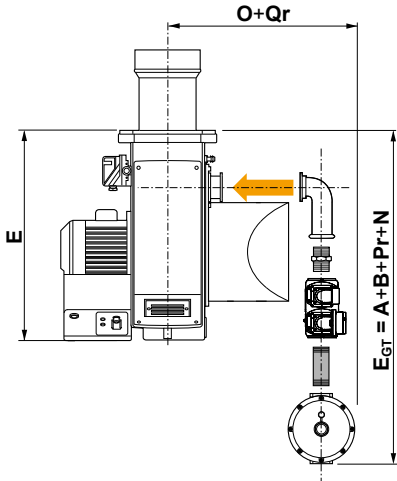

MULTICALOR 170.3 / 200.3

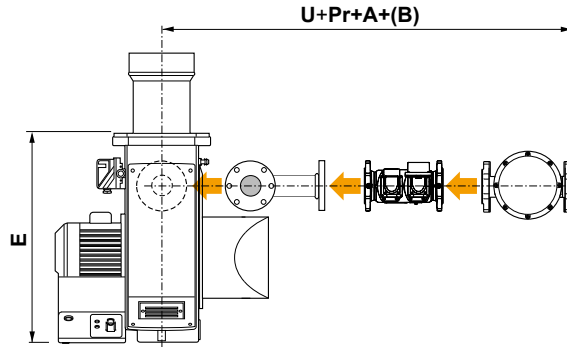

MULTICALOR 350.3 ... 600.1

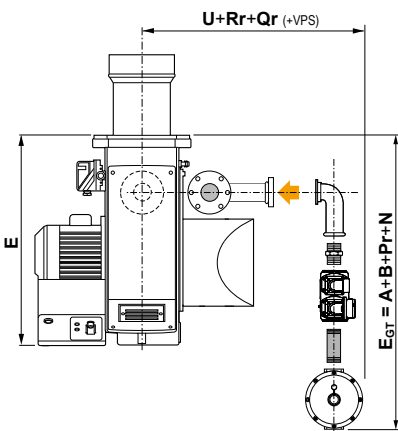

MULTICALOR 170.1 ... 600.1

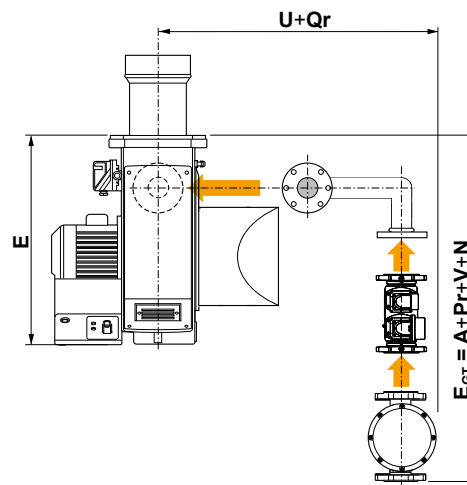

i To calculate the overall dimensions, consider the greater value between E and E_{GT}

OPTIONS**MODULATING
PID CONTROLLER**

Model	Code
Kit RWF50 for MULTICALOR 45 ... 200.1 PR-AB	3144025
Kit RWF50 for MULTICALOR 70 ... 600.1 PR	3147786
Kit RWF55	3147787

i Kit supplied loose; on-board assembly available upon request
See page 257 for more information on RWF kit features

**TEMPERATURE AND
PRESSURE PROBES**

Description	Code
Water probe, temperature range from 0 to 130 °C	3122316
Steam probe 0 ... 2 bar	3124100
Steam probe 0 ... 4 bar	3122317
Steam probe 0 ... 10 bar	3122318
Steam probe 0 ... 16 bar	3122319
Steam probe 0 ... 25 bar	3834314
Steam probe 0 ... 40 bar	3122320
Probe for external temperature from -35° to 50 °C	3122315
Hot air or liquid probe, temperature range from -50° to 400 °C	3122314
Thermocouple J type, temperature up to 750 °C (for RWF55 only)	3146725

**CUSTOMER INTERFACE
KIT DISPLAY**

Description	Code
Kit display AZL21 for burners equipped with Siemens LME7	3148779

**FREQUENCY
CONVERTER**

Description	Code	
IP21 with: • EMC filter • Inductor • Control panel	3 kW	3757054
	4 kW	3757055
	5,5 kW	3757056
	7,5 kW	3757057
	11 kW	3757058
	15 kW	3757059
IP55 with: • EMC filter • Inductor • Control panel	3 kW	3757067
	4 kW	3757068
	5,5 kW	3757069
	7,5 kW	3757070
	11 kW	3757071
	15 kW	3757072

OPTIONS**TIGHTNESS CONTROL**

For gas trains in EN676 Configuration a tightness control device must be included over 1200 kW

Description	Code
Kit VPS504 for MB-DLE and VGD DN65/80/100 valves, working with natural gas	3122303
Kit VPS504 for VGD20.503 valve, working with natural gas	3122305
Kit VDK for VGD valve, DN125 size	3141922
Kit LDU	3142314
Adapter for VPS pilot gas train	3142754

MAXIMUM GAS PRESSURE SWITCH

Description	Output range	Setting range	Code
Kit GPS 50	<6 MW	5 ... 50 mbar	3141921

GAS GOVERNOR WITH BUILT-IN FILTER

Default spring is neutral for outlet pressure range 10 - 30 mbar

Size	Maximum gas pressure	Code
Rp3/4"	500 mbar	3142520
Rp1"	500 mbar	3142521
Rp1"1/4	500 mbar	3142522
Rp1"1/2	500 mbar	3142523
Rp2"	500 mbar	3142524
Rp2"	1 bar	3142051
DN65	1 bar	3141983
DN80	1 bar	3142538
DN100	1 bar	on request
DN125	1 bar	on request

OPTIONS**SPRINGS FOR
GAS GOVERNOR**

Description	Size	Gas pressure range	Code	
Green spring	1/2", 3/4", 1"	5 ... 15 mbar	3142547	
Neutral spring		10 ... 30 mbar	3142548	
Violet spring		25 ... 80 mbar	3142549	
Brown spring		70 ... 160 mbar	3142550	
Blue spring		150 ... 280 mbar	3142551	
White spring		270 ... 350 mbar	3142552	
Green spring	1"1/4, 1"1/2	5 ... 15 mbar	3142553	
Neutral spring		10 ... 30 mbar	3142554	
Violet spring		20 ... 70 mbar	3142555	
Brown spring		65 ... 130 mbar	3142556	
White spring		120 ... 250 mbar	3142557	
Black spring		240 ... 350 mbar	3142558	
Green spring	2"	5 ... 15 mbar	3142559	
Neutral spring		10 ... 30 mbar	3142560	
Violet spring		30 ... 80 mbar	3142561	
Brown spring		70 ... 220 mbar	3142562	
Blue spring		210 ... 350 mbar	3142563	
Red spring		DN65, DN80	25-80 mbar	3144252
Violet spring	60-120 mbar		3144253	
Blue spring	100-220 mbar		3144254	
White spring	200-450 mbar		3144255	
Red spring	DN100		30-70 mbar	3144256
Violet spring			60-110 mbar	3144257
Brown spring		100-210 mbar	3144258	
White spring		200-450 mbar	3144060	

GAS FILTER

Size	Code
Rp3/4"	3142045
Rp1"	3142046
Rp1"1/2	3141954
Rp2"	3121384
DN65	3124111
DN80	3142088
DN100	3142205
DN125	3142206

ANTIVIBRATION JOINT

Size	Code
Rp3/4"	3122322
Rp1"	3122323
Rp1"1/4	3122324
Rp1"1/2	3122325
Rp2"	3122326
DN65	3142060
DN80	3122328
DN100	3122329
DN125	3142061

OPTIONS**MANUAL VALVE**

Size	Code
Rp3/4"	3142254
Rp1"	3121430
Rp1"1/4	3142253
Rp1"1/2	3142101
Rp2"	3142102
DN65	3142062
DN80	3143730
DN100	3141997
DN125	3141998

**MANOMETER +
PUSH BUTTON**

Description	Pressure range	Code
Gas manometer 1/2"	0...60 mbar	3142056
Gas manometer 1/4"	0...250 mbar	3142055
Gas manometer 1/4"	0...1000 mbar	3142054
Push button 1/2"		3142057
Push button 1/4"		3142058

OPTIONS**OIL FILTER**

Description	Suitable for	Code
Oil filter 3/8"	MULTICALOR 70 ... 140	3142085

OIL SPILL BACK NOZZLES

! Exclusively for
MULTICALOR 45...140

Size (kg/h)	Model	Connection	Code
26	Monarch	Threaded, 9/16"	3142326
33			3143301
37			3142511
39			3142503
49			3142351
50			3142512
62			3143299
71			3142504
76			3142488
90			3145764
97			3141817

OIL SPILL BACK NOZZLES

! All burners except
MULTICALOR 45...140

Size (kg/h)	Model	Connection	Code
40	Fluidics W2 50°	Threaded, 7/8"	3145231
50			3145232
60			3142763
70			3145233
80			3145234
90			3145235
100			3142704
115			3142564
130			3142515
145			3142516
160			3142421
180			3142492
200			3142690
225			3142489
250			3142768
275			3142805
300			3142490
330			3142703
360	3142513		
400	3142497		
450	3142483		
500	3142699		

KIT FOR AUTOMATIC FUEL SWITCH GAS/OIL

Description	Code
Kit automatic fuel switch	3142021

i The standard version works with manual fuel selection mode; with this kit, the change of fuel is activated by a gas pressure switch or by a timer

- MULTICALOR models from 700.1 to 1800.1 are monoblock force-draught burners working with gas or light oil and covering an output range from 1500 to 17000 kW
- These models are available in two stage progressive mechanical in both gas and light oil operation; they can be transformed in modulating with the installation of a power regulator and dedicated probes (see page 257)
- Electronic versions are also available: see page 196
- As all the Ecoflam burners they are equipped with an adjustable combustion head for easy regulation and matching with different combustion chambers
- The structure of the burners allow easy access to the internal components for fast start-up and reduced maintenance time and space
- Multiple gas train matching are available according to the inlet gas pressure



WORKING DIAGRAM

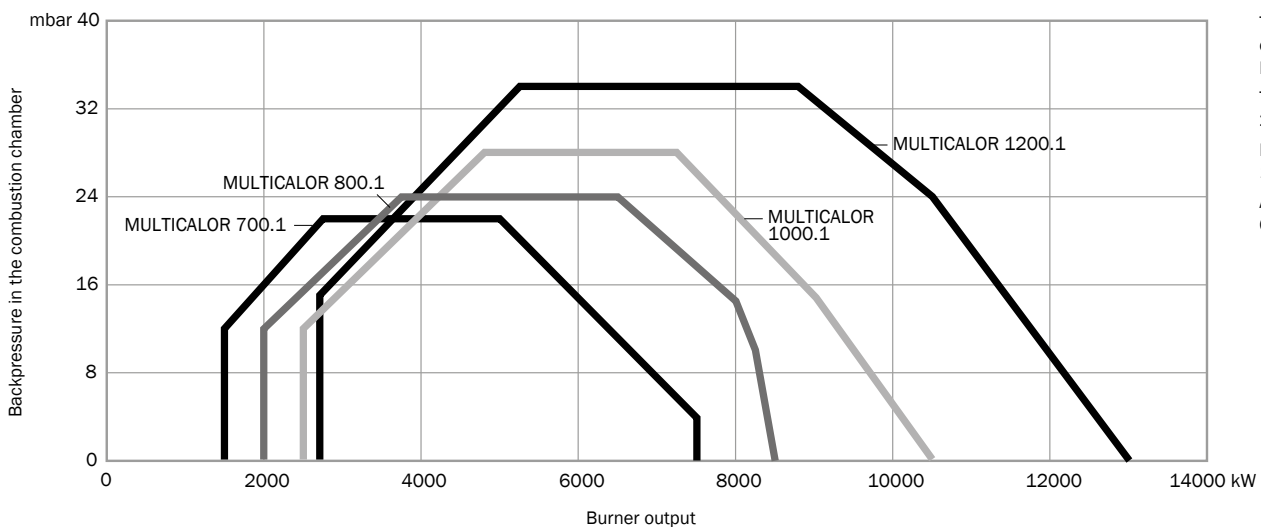

Test conditions conforming to EN676 and EN267
 Temperature: 20 °C
 Pressure: 1013,5 mbar
 Altitude: 0 m a.s.l.

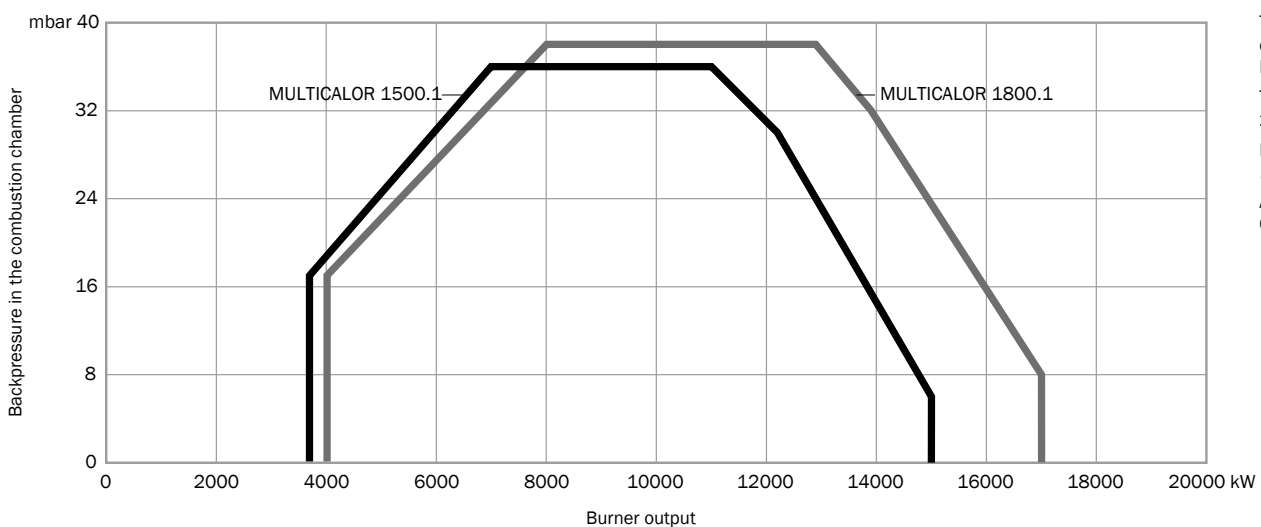

Test conditions conforming to EN676 and EN267
 Temperature: 20 °C
 Pressure: 1013,5 mbar
 Altitude: 0 m a.s.l.

TECHNICAL DATA

Model	Operation	Output (kW)	Flow rate (kg/h)	Control box	Flame detector	Power supply	Motor (kW)	Emissions
MULTICALOR 700.1	PR	1500 - 7500	126 - 634	LME73	QRA2	3/400/50Hz	15	Class 2 / 1
MULTICALOR 800.1	PR	2000 - 8500	169 - 718	LME73	QRA2	3/400/50Hz	18,5	Class 2 / 1
MULTICALOR 1000.1	PR	2500 - 10500	211 - 887	LME73	QRA2	3/400/50Hz	22	Class 2 / 1
MULTICALOR 1200.1	PR	2700 - 13000	228 - 1099	LME73	QRA2	3/400/50Hz	37	Class 2 / 1
MULTICALOR 1500.1	PR	3690 - 15000	312 - 1268	LME73	QRA2	3/400/50Hz	45	Class 2 / 1
MULTICALOR 1800.1	PR	4000 - 17000	338 - 1437	LME73	QRA2	3/400/50Hz	55	Class 2 / 1

CODES

■ PR - Two stage progressive/modulating mechanical in gas and in light oil

Model	TC	TL
MULTICALOR 700.1 PR	3146100	on request
MULTICALOR 800.1 PR	3146121	on request
MULTICALOR 1000.1 PR	3146122	on request
MULTICALOR 1200.1 PR	3146158	on request
MULTICALOR 1500.1 PR	3146180	on request
MULTICALOR 1800.1 PR	3146406	on request

! Nozzle not included in the code of the burner - see page 253

OTHER AVAILABLE CONFIGURATIONS

- Continuous ventilation (CV)
- Post-purge
- 60 Hz
- Special versions on request according to feasibility

i All non-standard configurations are available on request: contact us to know more

OVERALL DIMENSIONS

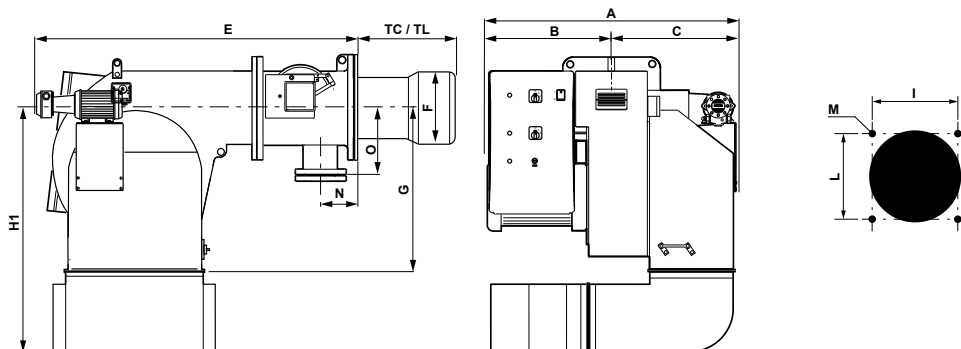

Model	A	B	C	TC	TL	E	F	G	H1 ¹	I	L	M	N	O
MULTICALOR 700.1	1370	740	630	470	-	1640	420	775	1270	460	460	M20	195	232
MULTICALOR 800.1	1370	740	630	470	-	1640	420	775	1270	460	460	M20	195	232
MULTICALOR 1000.1	1370	740	630	470	-	1640	420	775	1270	460	460	M20	195	232
MULTICALOR 1200.1	1430	800	630	470	-	1640	450	775	1270	460	460	M20	195	232

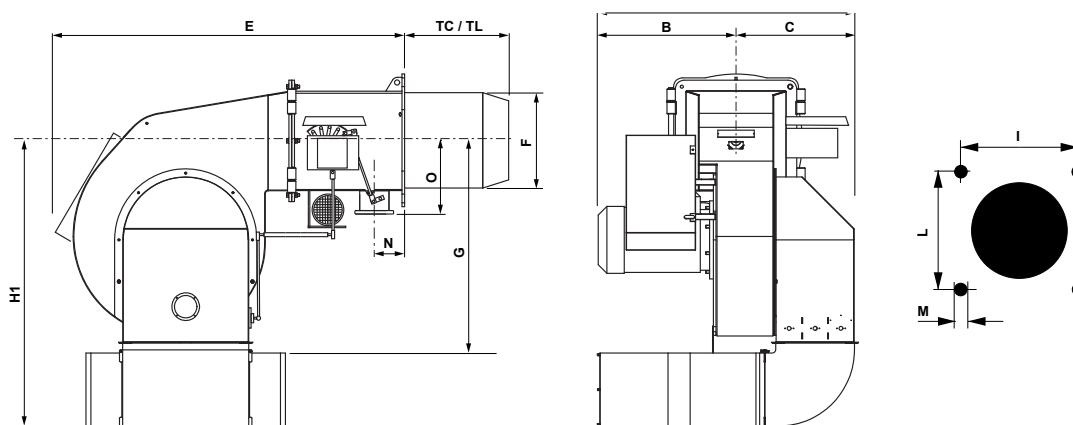

Model	A	B	C	TC	TL	E	F	G	H1 ¹	I	L	M	N	O
MULTICALOR 1500.1	1700	800	900	590	-	1910	550	1320	1670	619	619	M20	210	320
MULTICALOR 1800.1	1770	870	900	590	-	1910	550	1320	1670	619	619	M20	210	320

i Dimensions in mm
 Head length: TC short / TL long
¹: with silencer (optional)

PACKAGING

The complete burner with gas train and filter is delivered in a wooden box containing boiler fixing accessories and a bag with technical documentation.

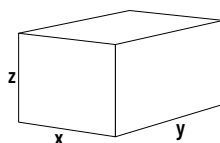

Model	x	y	z	kg
MULTICALOR 700.1	1760	2390	1470	753
MULTICALOR 800.1	1760	2390	1470	830
MULTICALOR 1000.1	1760	2390	1470	908
MULTICALOR 1200.1	1760	2390	1470	908
MULTICALOR 1500.1	2090	2800	1970	1600
MULTICALOR 1800.1	2090	2800	1970	1600

Dimensions in mm.
 Values referred to burners in standard version; the dimensions of the package may vary according to the configuration chosen

GAS TRAINS

Model	Pressure (mbar) min - max	Model	Size	Codes	Connection pipe	Filter
for MULTICALOR 700.1	60 - 500	VGD 40.125	DN125	3146008	3145829	3142206
	75 - 500	VGD 40.100	DN100	3146007	3145822	3142205
	140 - 500	VGD 40.080	DN80	3146006	3145816	3142088
	280 - 500	VGD 40.065	DN65	3146005	3145801	3124111
for MULTICALOR 800.1	85 - 500	VGD 40.125	DN125	3146008	3145829	3142206
	110 - 500	VGD 40.100	DN100	3146007	3145822	3142205
	210 - 500	VGD 40.080	DN80	3146006	3145816	3142088
	410 - 500	VGD 40.065	DN65	3146005	3145801	3124111
for MULTICALOR 1000.1	115 - 500	VGD 40.125	DN125	3146008	3145829	3142206
	165 - 500	VGD 40.100	DN100	3146007	3145822	3142205
	290 - 500	VGD 40.080	DN80	3146006	3145816	3142088
	550 - 500	VGD 40.065	DN65	3146005	3145801	3124111
for MULTICALOR 1200.1	175 - 500	VGD 40.125	DN125	3146008	3145829	3142206
	230 - 500	VGD 40.100	DN100	3146007	3145822	3142205
	420 - 500	VGD 40.080	DN80	3146006	3145816	3142088
for MULTICALOR 1500.1	150 - 500	VGD 40.125	DN125	3146008	3145829	3142206
	230 - 500	VGD 40.100	DN100	3146007	3145822	3142205
	450 - 500	VGD 40.080	DN80	3146006	3145816	3142088
for MULTICALOR 1800.1	210 - 500	VGD 40.125	DN125	3146008	3145829	3142206
	330 - 500	VGD 40.100	DN100	3146007	3145822	3142205

- ! Default blank spring: head pressure 0...22 mbar; choose and change spring and damping (to be fitted during installation on site)
 For minimum inlet pressures higher than 250 mbar, choose the pressure switch GW500 (to be fitted during installation on site)
 For gas trains in EN676 Configuration a tightness control device must be included over 1200 kW

GAS TRAINS - DIMENSIONS

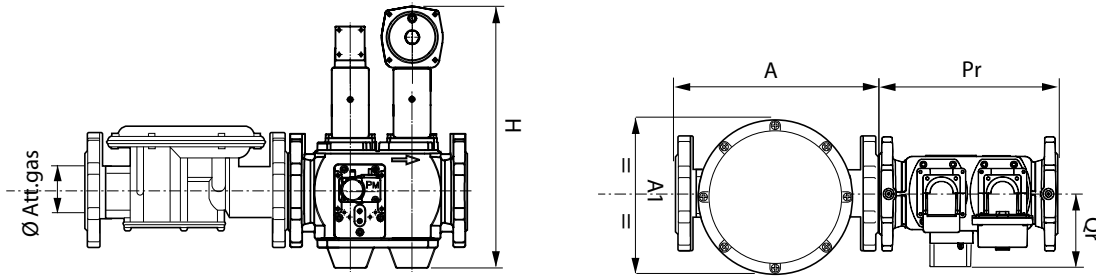

Code	Gas train	\varnothing	Dimensions (mm)		
			Pr	Qr	H
3146005	GT-S1-VGD40-DN65-PS3	DN65	290	127,3	421
3146006	GT-S1-VGD40-DN80-PS3	DN80	310	127,3	445
3146007	GT-S1-VGD40-DN100-PS3	DN100	350	145,4	476
3146008	GT-S1-VGD40-DN125-PS3	DN125	400	158,4	524

■ CONNECTION PIPE

Code	Dimensions (mm)		
	T	U	V
3145801	202	820	105
3145816	221	820	124
3145822	158	820	158
3145829	284	820	143

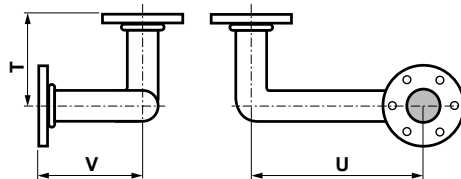

■ GAS FILTER

Code	\varnothing	Dimensions (mm)	
		A	A1
3124111	DN65	290	212
3142088	DN80	320	240
3142205	DN100	380	280
3142206	DN125	380	280

■ TOTAL DIMENSIONS CALCULATION

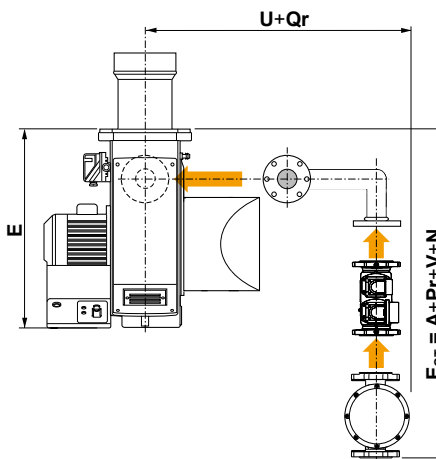

i To calculate the overall dimensions, consider the greater value between E and E_{gr}

OPTIONS

MODULATING PID CONTROLLER



Description	Code
Kit RWF50	3143713
Kit RWF55	3143714

i Kit supplied loose; on-board assembly available upon request
See page 257 for more information on RWF kit features

TEMPERATURE AND PRESSURE PROBES



Description	Code
Water probe, temperature range from 0 to 130 °C	3122316
Steam probe 0 ... 2 bar	3124100
Steam probe 0 ... 4 bar	3122317
Steam probe 0 ... 10 bar	3122318
Steam probe 0 ... 16 bar	3122319
Steam probe 0 ... 25 bar	3834314
Steam probe 0 ... 40 bar	3122320
Probe for external temperature from -35° to 50 °C	3122315
Hot air or liquid probe, temperature range from -50° to 400 °C	3122314
Thermocouple J type, temperature up to 750 °C (for RWF55 only)	3146725

CUSTOMER INTERFACE KIT DISPLAY

Description	Code
Kit display AZL21 for burners equipped with Siemens LME7	3148779

FREQUENCY CONVERTER



Description	Code	
IP21 with: • EMC filter • Inductor • Control panel	15 kW	3757059
	18,5 kW	3757060
	22 kW	3757061
	30 kW	3757062
	37 kW	3757063
	45 kW	3757064
	55 kW	3757065
	15 kW	3757072
	18,5 kW	3757073
	22 kW	3757074
IP55 with: • EMC filter • Inductor • Control panel	30 kW	3757075
	37 kW	3757076
	45 kW	3757077
	55 kW	3757078

TIGHTNESS CONTROL

! For gas trains in EN676
Configuration a tightness
control device must be
included over 1200 kW

Description	Code
Kit VPS504 for VGD DN65/80/100 valves, working with natural gas	3122303
Kit VDK for VGD valve, DN125 size	3141922
Kit LDU	3142314
Adaptor for VPS pilot gas train	3142754

OPTIONS

MAXIMUM GAS PRESSURE SWITCH

Description	Output range	Setting range	Code
Kit GPS 150	6 ... 15 MW	30 ... 150 mbar	3142033
Kit GPS 500	>15 MW	50 ... 500 mbar	3145166

GAS GOVERNOR WITH BUILT-IN FILTER

! Default spring is neutral for outlet pressure range 10 - 30 mbar

Size	Maximum gas pressure	Code
DN65	1 bar	3141983
DN80	1 bar	3142538
DN100	1 bar	on request
DN125	1 bar	on request

SPRINGS FOR GAS GOVERNOR

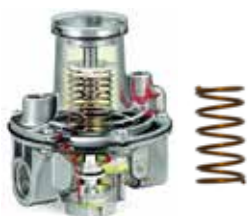

Description	Size	Gas pressure range	Code
Red spring	DN65, DN80	25-80 mbar	3144252
Violet spring		60-120 mbar	3144253
Blue spring		100-220 mbar	3144254
White spring		200-450 mbar	3144255
Red spring	DN100	30-70 mbar	3144256
Violet spring		60-110 mbar	3144257
Brown spring		100-210 mbar	3144258
White spring		200-450 mbar	3144060

GAS FILTER



Size	Code
DN65	3124111
DN80	3142088
DN100	3142205
DN125	3142206

ANTIVIBRATION JOINT



Size	Code
DN65	3142060
DN80	3122328
DN100	3122329
DN125	3142061

MANUAL VALVE



Size	Code
DN65	3142062
DN80	3143730
DN100	3141997
DN125	3141998

OPTIONS

MANOMETER +
PUSH BUTTON

Description	Pressure range	Code
Gas manometer 1/2"	0...60 mbar	3142056
Gas manometer 1/4"	0...250 mbar	3142055
Gas manometer 1/4"	0...1000 mbar	3142054
Push button 1/2"		3142057
Push button 1/4"		3142058

OIL SPILL BACK
NOZZLES

Size (kg/h)	Model	Connection	Code
300	Fluidics W2 50°	Threaded, 7/8"	3142490
330			3142703
360			3142513
400			3142497
450			3142483
500			3142699
600			3142506
650			3142870
700			3145236

KIT FOR AUTOMATIC
FUEL SWITCH GAS/OIL

Description	Code
Kit automatic fuel switch	3142021



The standard version works with manual fuel selection mode; with this kit, the change of fuel is activated by a gas pressure switch or by a timer

- MULTICALOR models from 70 to 600.1 are monoblock force-draught burners working with gas or light oil and covering an output range from 190 to 5800 kW
- The new MULTICALOR models from 170.3 to 400.3 are equipped with low emissions combustion head and are classified Low NO_x class 3 when operating in gas (NO_x ≤ 80 mg/kWh according to EN676) and class 2 when operating in light oil (NO_x ≤ 185 mg/kWh according to EN267)
- All MULTICALOR PRE models are available in two stage progressive electronic configuration with Burner Management System
- All models are fully electronically controlled for smooth operation and simple and effective programming operation
- As all the Ecoflam burners they are equipped with an adjustable combustion head for easy regulation and matching with different combustion chambers
- The structure of the burners allow easy access to the internal components for fast start-up and reduced maintenance time and space
- Multiple gas train matching are available according to the inlet gas pressure



WORKING DIAGRAM

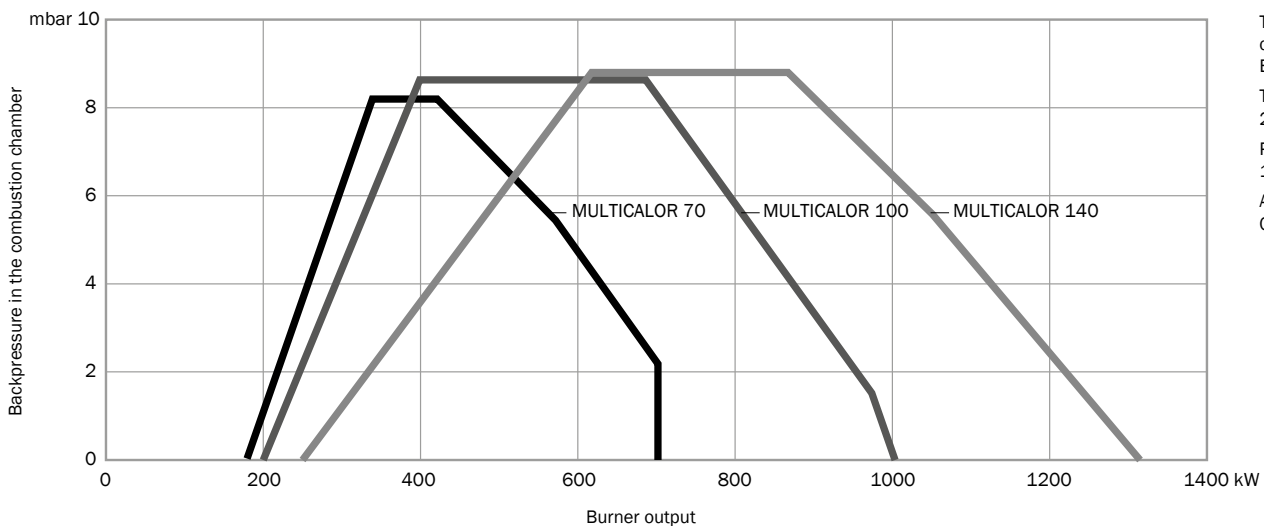

Test conditions conforming to EN676 and EN267
 Temperature: 20 °C
 Pressure: 1013,5 mbar
 Altitude: 0 m a.s.l.

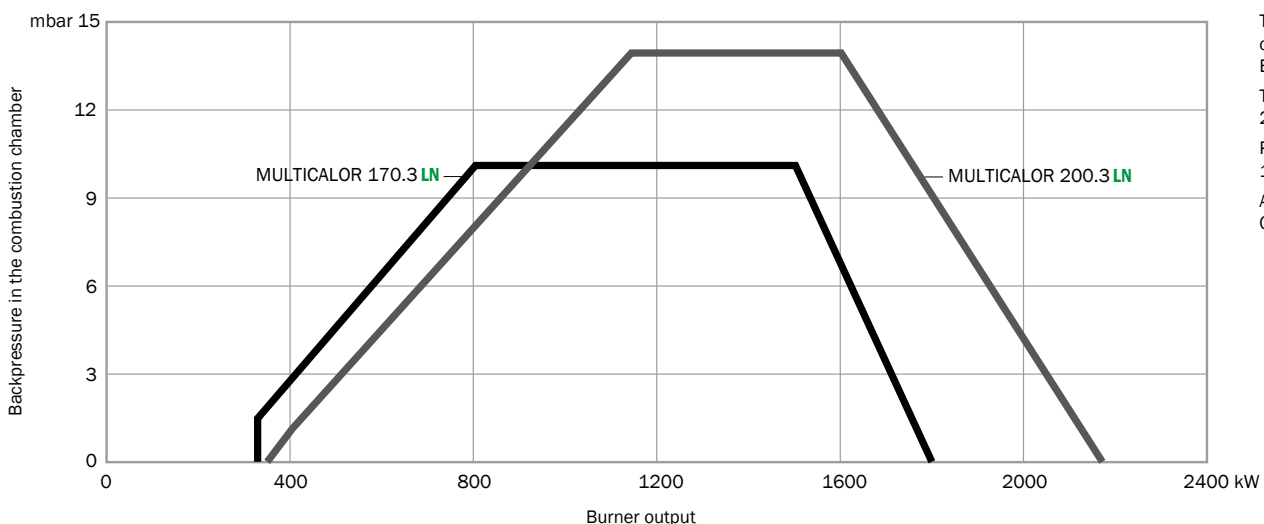

Test conditions conforming to EN676 and EN267
 Temperature: 20 °C
 Pressure: 1013,5 mbar
 Altitude: 0 m a.s.l.

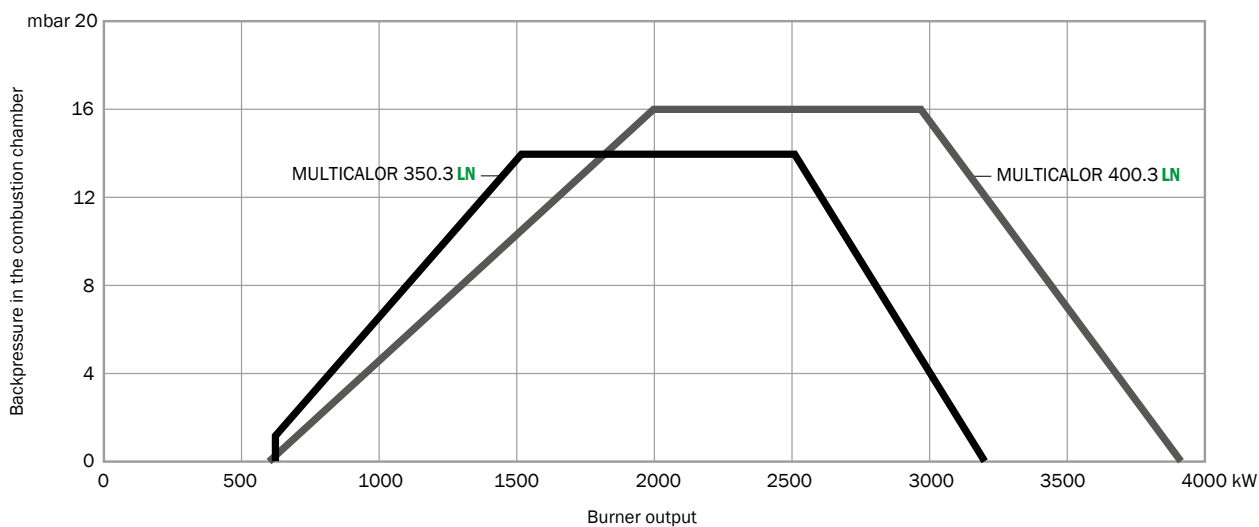

Test conditions conforming to EN676 and EN267
 Temperature: 20 °C
 Pressure: 1013,5 mbar
 Altitude: 0 m a.s.l.

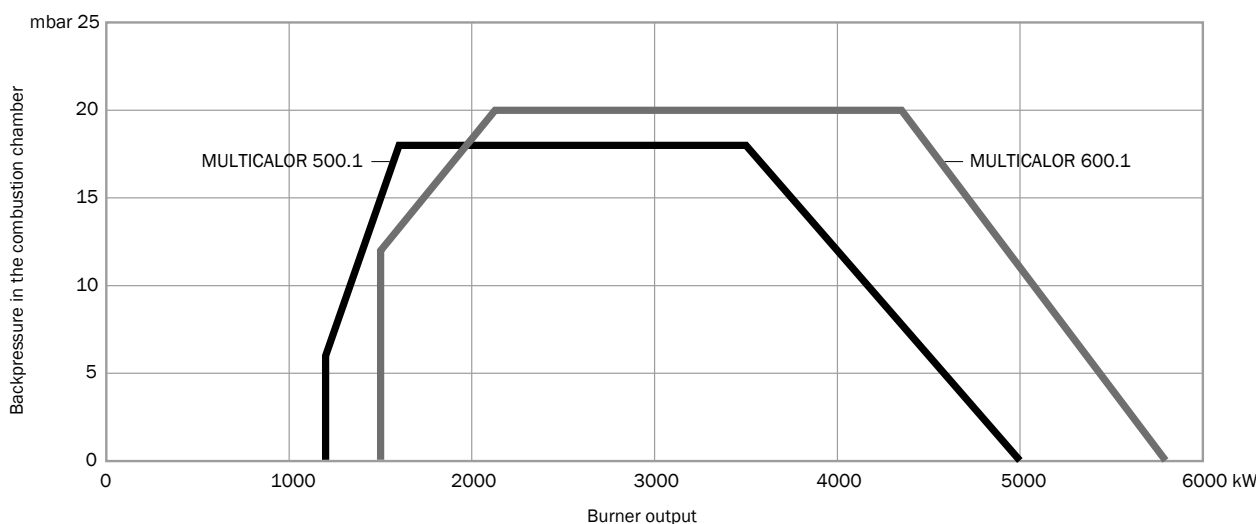

Test conditions conforming to EN676 and EN267
 Temperature: 20 °C
 Pressure: 1013,5 mbar
 Altitude: 0 m a.s.l.

TECHNICAL DATA

Model	Operation	Output (kW)	Flow rate (kg/h)	Control box	Flame det.	Power supply	Motor (kW)	NOx emission
MULTICALOR 70	PRE	190 - 700	16 - 59	BT340	QRA2	3/230-400/50Hz	1,1	Class 2 / 1
MULTICALOR 100	PRE	200 - 1000	16,9 - 84,3	BT340	QRA2	3/230-400/50Hz	1,1	Class 2 / 1
MULTICALOR 140	PRE	250 - 1300	21,1 - 110	BT340	QRA2	3/230-400/50Hz	2,2	Class 2 / 1
MULTICALOR 170.3 LN	PRE FCA 72H FCA72H	320 - 1800	27 - 151	BT335 ¹	KLC20 ²	3/230-400/50Hz	3	Class 3 / 2
MULTICALOR 200.3 LN	PRE FCA 72H FCA72H	340 - 2160	28,8 - 182	BT335 ¹	KLC20 ²	3/230-400/50Hz	4	Class 3 / 2
MULTICALOR 350.3 LN	PRE FCA 72H FCA72H	610 - 3200	51 - 270	BT335 ¹	KLC20 ²	3/230-400/50Hz	5,5	Class 3 / 2
MULTICALOR 400.3 LN	PRE FCA 72H FCA72H	600 - 3900	51 - 329	BT335 ¹	KLC20 ²	3/230-400/50Hz	7,5	Class 3 / 2
MULTICALOR 500.1	PRE	1200 - 5000	101 - 423	BT340	QRA2	3/400/50Hz	11	Class 2 / 1
MULTICALOR 600.1	PRE	1500 - 5800	126 - 490	BT340	QRA2	3/400/50Hz	15	Class 2 / 1

¹: BT330 on 72H versions
²: FFS08-UV1 on 72H versions

CODES

■ PRE - Two stage progressive/modulating electronic in gas and in light oil

Model	TC	TL
MULTICALOR 70 PRE	on request	3145139
MULTICALOR 100 PRE	on request	3145140
MULTICALOR 140 PRE	on request	3145141
MULTICALOR 170.3 LN PRE	3149316	3149317
MULTICALOR 200.3 LN PRE	3149318	3149319
MULTICALOR 350.3 LN PRE	3149322	3149323
MULTICALOR 400.3 LN PRE	3149324	3149325
MULTICALOR 500.1 PRE	3145148	3145149
MULTICALOR 600.1 PRE	3145150	3145151

■ PRE FCA - Two stage progressive/modulating electronic with frequency converter arrangement

Model	TC	TL
MULTICALOR 170.3 LN PRE FCA	3149344	3149345
MULTICALOR 200.3 LN PRE FCA	3149346	3149347
MULTICALOR 350.3 LN PRE FCA	3149350	3149351
MULTICALOR 400.3 LN PRE FCA	3149352	3149353

■ PRE 72H - Two stage progressive/modulating electronic, 72-hour continuous operation

Model	TC	TL
MULTICALOR 170.3 LN PRE 72H	3149330	3149331
MULTICALOR 200.3 LN PRE 72H	3149332	3149333
MULTICALOR 350.3 LN PRE 72H	3149336	3149337
MULTICALOR 400.3 LN PRE 72H	3149338	3149339

■ PRE FCA 72H - Two stage progressive/modulating electronic with frequency converter arrangement, 72-hour continuous operation

Model	TC	TL
MULTICALOR 170.3 LN PRE FCA 72H	3149358	3149359
MULTICALOR 200.3 LN PRE FCA 72H	3149360	3149361
MULTICALOR 350.3 LN PRE FCA 72H	3149364	3149365
MULTICALOR 400.3 LN PRE FCA 72H	3149366	3149367

! Nozzle not included in the code of the burner - see page 253

OTHER AVAILABLE CONFIGURATIONS

- Continuous ventilation (CV)
- Post-purge
- 60 Hz
- Special versions on request according to feasibility

i All non-standard configurations are available on request: contact us to know more

OVERALL DIMENSIONS

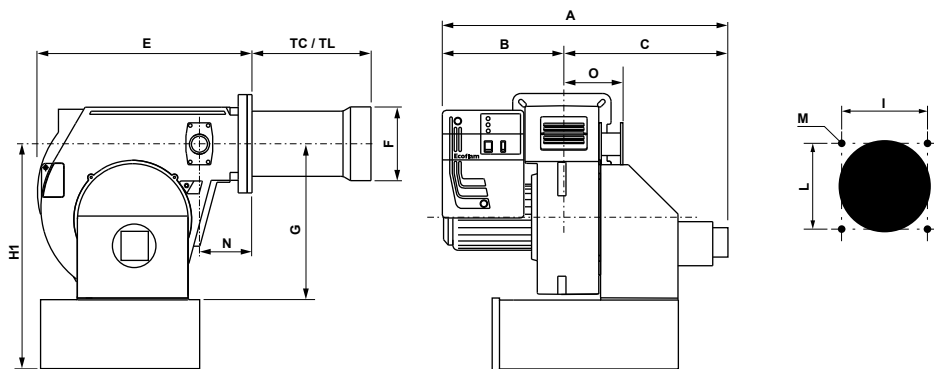

Model	A	B	C	TC	TL	E	F	G	H1 ¹	I	L	M	N	O
MULTICALOR 70 PRE	1045	510	535	175	395	555	180	390	600	190	190	M10	140	165
MULTICALOR 100 PRE	1045	510	535	175	395	555	190	390	600	190	190	M10	140	165
MULTICALOR 140 PRE	1070	510	560	307	457	555	215	390	600	190	190	M10	140	165

i Dimensions in mm
 Head length: TC short / TL long
¹: with silencer (optional)

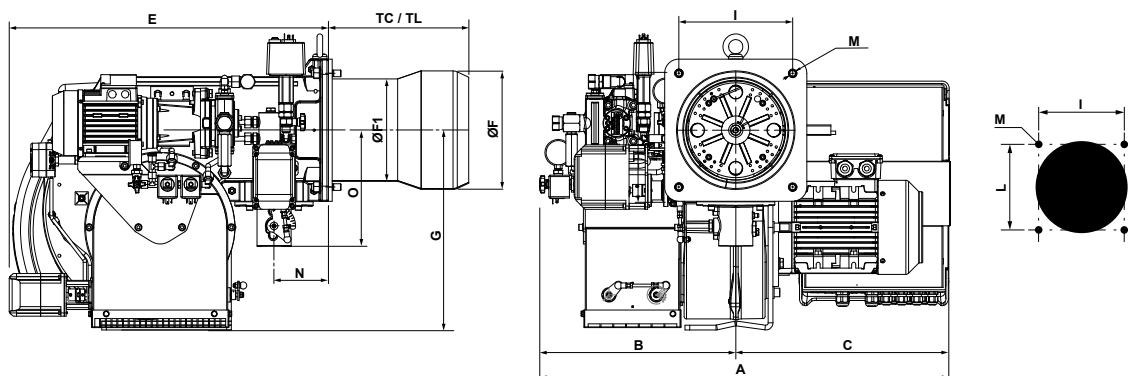

Model	A	B	C	TC	TL	E	F	F1	G	I	L	M	N	O
MULTICALOR 170.3 LN PRE	855	402	453	288	488	681	250	216	421	240	240	M14	123	245
MULTICALOR 200.3 LN PRE	855	402	453	288	488	681	270	216	421	240	240	M14	123	245
MULTICALOR 350.3 LN PRE	917	460	457	328	358	789	290	241	471	315	315	M16	195	245
MULTICALOR 400.3 LN PRE	917	460	457	344	544	789	320	248	471	315	315	M16	195	245
MULTICALOR 500.1 PRE	1200	610	590	355	555	1000	320	-	570	330	330	M16	195	250
MULTICALOR 600.1 PRE	1200	610	590	355	555	1000	320	-	570	330	330	M16	195	250

i Dimensions in mm
 Head length: TC short / TL long

PACKAGING

The complete burner with gas train and filter is delivered in a carton box containing boiler fixing accessories and a bag with technical documentation.

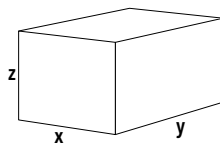

Model	x	y	z	kg
MULTICALOR 70	800	1070	590	57
MULTICALOR 10	800	1070	590	66
MULTICALOR 140	1150	1380	960	130
MULTICALOR 170.3 LN	1150	1380	960	170
MULTICALOR 200.3 LN	1150	1380	960	190
MULTICALOR 350.3 LN	1590	1590	1080	328
MULTICALOR 400.3 LN	1590	1590	1080	334
MULTICALOR 500.1	1590	1590	1080	420
MULTICALOR 600.1	1590	1590	1080	440

Dimensions in **mm**.

Values referred to burners in standard version; the dimensions of the package may vary according to the configuration chosen

GAS TRAINS

Model	Pressure (mbar) min - max	Model	Size	Codes	Connection pipe	Filter
for MULTICALOR 70	17 - 360	MB-DLE 420	2"	3145934	-	included
	25 - 360	MB-DLE 415	1"1/2	3145933		included
	75 - 360	MB-DLE 410	1"	3145931		included
for MULTICALOR 100	27 - 360	MB-DLE 420	2"	3145934	-	included
	35 - 360	MB-DLE 415	1"1/2	3145933		included
	75 - 360	MB-DLE 412	1"1/4	3145932		included
for MULTICALOR 140	40 - 360	MB-DLE 420	2"	3145934	-	included
	50 - 360	MB-DLE 415	1"1/2	3145933		included
	100 - 360	MB-DLE 412	1"1/4	3145932		included
for MULTICALOR 170.3 LN	60 - 360	MB-DLE 420	2"	3144773	3144686	included
	85 - 360	MB-DLE 415	1"1/2	3144772	3144686	included
	20 - 500	VGD 40.080	DN80	3145814	3148772	3142088
	35 - 500	VGD 40.065	DN65	3145793	3148771	3124111
	45 - 500	VGD 20.5011	2"	3147672	3144686	3121384
for MULTICALOR 200.3 LN	75 - 360	MB-DLE 420	2"	3144773	3144686	included
	100 - 360	MB-DLE 415	1"1/2	3144772	3144686	included
	23 - 500	VGD 40.080	DN80	3145814	3148772	3142088
	35 - 500	VGD 40.065	DN65	3145793	3148771	3124111
	60 - 500	VGD 20.5011	2"	3147672	3144686	3121384
for MULTICALOR 350.3 LN	22 - 500	VGD 40.100	DN100	3145817	3148773	3142205
	35 - 500	VGD 40.080	DN80	3145814	3148772	3142088
	55 - 500	VGD 40.065	DN65	3145793	3148771	3124111
	100 - 500	VGD 20.5011	2"	3147672	3149594	3121384
for MULTICALOR 400.3 LN	30 - 500	VGD 40.100	DN100	3145817	3148768	3142205
	50 - 500	VGD 40.080	DN80	3145814	3148767	3142088
	90 - 500	VGD 40.065	DN65	3145793	3148766	3124111
	170 - 500	VGD 20.5011	2"	3145790	4396173	3121384
for MULTICALOR 500.1	35 - 500	VGD 40.125	DN125	3145823	3145830	3142206
	45 - 500	VGD 40.100	DN100	3145817	3145821	3142205
	75 - 500	VGD 40.080	DN80	3145814	3145864	3142088
	140 - 500	VGD 40.065	DN65	3145793	3145997	3124111
	250 - 500	VGD 20.503	2"	3145790	4396173	3121384
for MULTICALOR 600.1	50 - 500	VGD 40.125	DN125	3145823	3145830	3142206
	60 - 500	VGD 40.100	DN100	3145817	3145821	3142205
	100 - 500	VGD 40.080	DN80	3145814	3145864	3142088
	180 - 500	VGD 40.065	DN65	3145793	3145997	3124111
	340 - 500	VGD 20.503	2"	3145790	4396173	3121384

- !** Default blank spring: head pressure 0...22 mbar; choose and change spring and damping (to be fitted during installation on site)
 For minimum inlet pressures higher than 250 mbar, choose the pressure switch GW500 (to be fitted during installation on site)
 For gas trains in EN676 Configuration a tightness control device must be included over 1200 kW

GAS TRAINS - DIMENSIONS

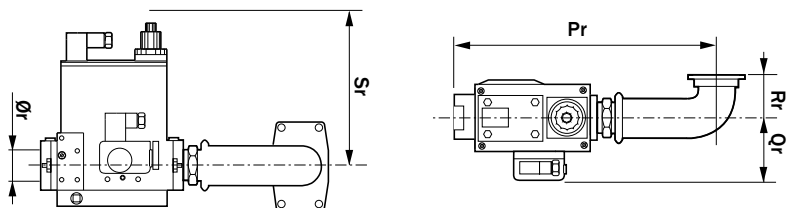

Code	Gas train	\varnothing	Dimensions (mm)				
			Pr	Qr	Rr	Sr	$\varnothing r$
3145931	GT-D1-MBDLE410-RP25-PS2	Rp1"	330	102	85	160	1"
3145932	GT-D1-MBDLE412-RP32-PS2	Rp1"1/2	410	90	85	175	1"1/2
3145933	GT-D1-MBDLE415-RP25-PS2	Rp1"1/2	410	90	85	175	1"1/2
3145934	GT-D1-MBDLE420-RP32-PS2	Rp2"	420	90	85	175	2"

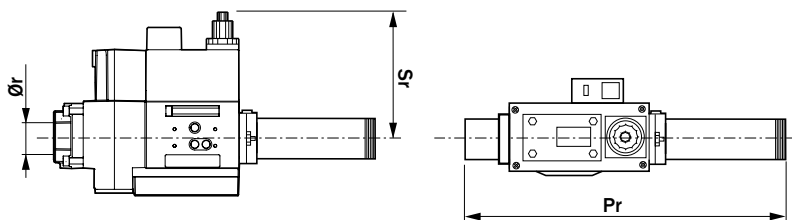

Code	Gas train	\varnothing	Dimensions (mm)		
			Pr	Sr	$\varnothing r$
3144772	GT-D1-MBDLE415-RP40-PS2	Rp1"1/2	589	169	1"1/2
3144773	GT-D1-MBDLE420-RP50-PS2	Rp2"	589	217	2"

CONNECTION PIPE

Code	Dimensions (mm)	
	T	U
3144686	100	32

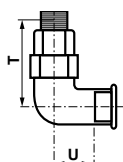

TOTAL DIMENSIONS CALCULATION

MULTICALOR 45 ... 140

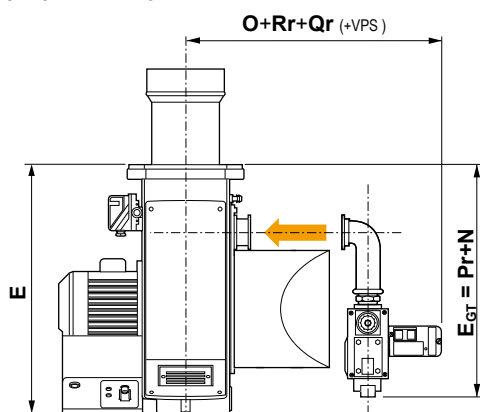

MULTICALOR 170.3 / 200.3

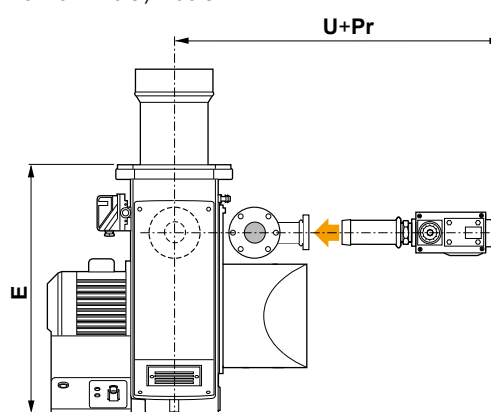

i To calculate the overall dimensions, consider the greater value between E and E_{GT}

GAS TRAINS - DIMENSIONS

■ VGD 20... PS2-S

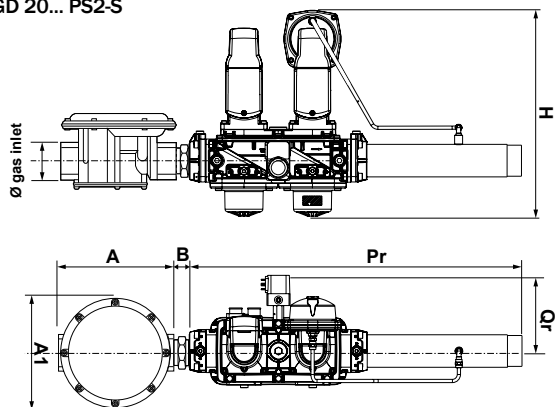

Code	Model	Ø	Dimensions (mm)			
			Pr	Qr	H	B
3147672	GT-S1-VGD20-RP50-PS2-S	Rp2"	628	34,9	382	36

■ VGD 20... PS2

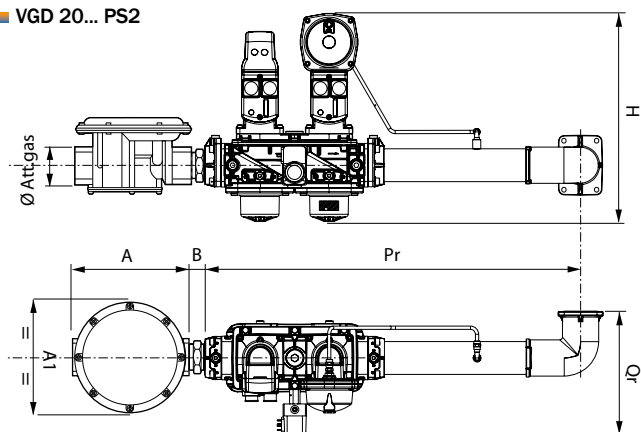

■ VGD 40... PS2

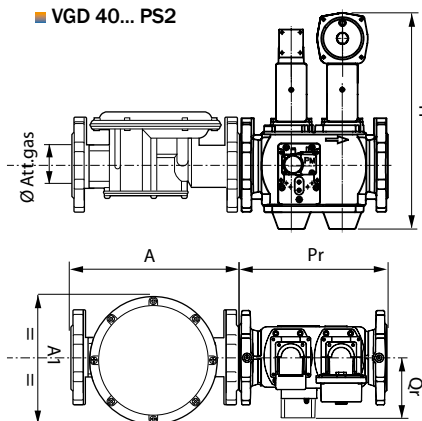

Code	Gas train	Ø	Dimensions (mm)			
			Pr	Qr	H	B
3145790	GT-S1-VGD20-RP50-PS2	Rp2"	689	226	382	36
3145793	GT-S1-VGD40-DN65-PS2	DN65	290	127,3	421	-
3145814	GT-S1-VGD40-DN80-PS2	DN80	310	127,3	445	-
3145817	GT-S1-VGD40-DN100-PS2	DN100	350	145,4	476	-
3145823	GT-S1-VGD40-DN125-PS2	DN125	400	158,4	524	-

GAS TRAINS - DIMENSIONS

CONNECTION PIPE

Code	Pic.	Dimensions (mm)		
		T	U	V
4396173	1	85	580	-
3144686	3	100	32	-
3145821	2	122	668	122
3145830	2	156	718	122
3145864	2	122	668	122
3145997	2	122	668	122
3148766	2	122	778	145
3148767	2	145	778	120
3148768	2	145	778	120
3148769	2	145	788	157
3148771	4	100	602	106
3148772	4	100	602	125
3148773	4	100	602	125
3149594	5	100	532	-

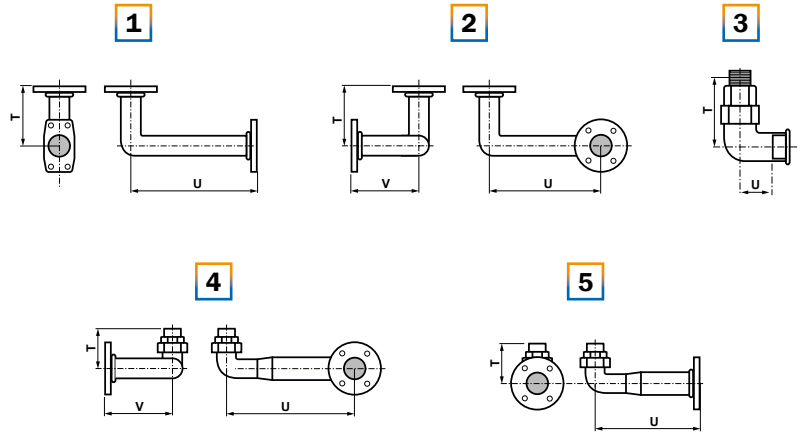

GAS FILTER

Code	Ø	Dimensions (mm)		
		A	A1	B
3121384	Rp2"	186	186	>100
3124111	DN65	290	212	-
3142088	DN80	320	240	-
3142205	DN100	380	280	-
3142206	DN125	380	280	-

TOTAL DIMENSIONS CALCULATION

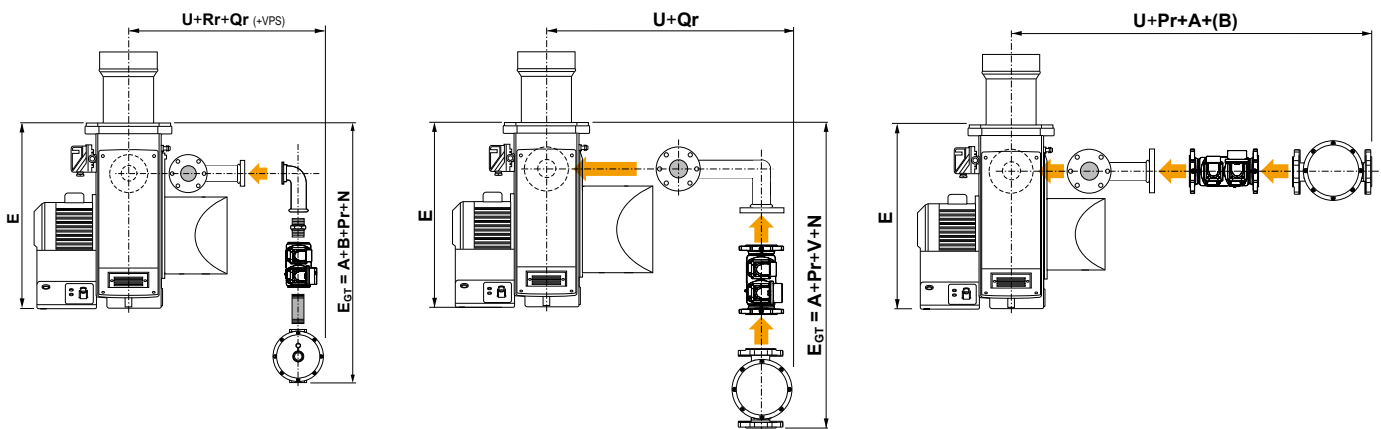

i To calculate the overall dimensions, consider the greater value between E and E_{GT}

OPTIONS**MODULATING
PID CONTROLLER**

Description	Code
Kit RWF50 for MULTICALOR 70/100/140 and 500.1/600.1	3143713
Kit RWF50 for MULTICALOR 170.3 ... 400.3	3147786
Kit RWF55 for MULTICALOR 70/100/140 and 500.1/600.1	3143714
Kit RWF55 for MULTICALOR 170.3 ... 400.3	4396228

i Kit supplied loose; on-board assembly available upon request
See page 257 for more information on RWF kit features

**TEMPERATURE AND
PRESSURE PROBES**

Description	Code
Water probe, temperature range from 0 to 130 °C	3122316
Steam probe 0 ... 2 bar	3124100
Steam probe 0 ... 4 bar	3122317
Steam probe 0 ... 10 bar	3122318
Steam probe 0 ... 16 bar	3122319
Steam probe 0 ... 25 bar	3834314
Steam probe 0 ... 40 bar	3122320
Probe for external temperature from -35° to 50 °C	3122315
Hot air or liquid probe, temperature range from -50° to 400 °C	3122314
Thermocouple J type, temperature up to 750 °C (for RWF55 only)	3146725

**FREQUENCY
CONVERTER**

Description		Code
	3 kW	3757054
	4 kW	3757055
IP21 with: • EMC filter • Inductor • Control panel	5,5 kW	3757056
	7,5 kW	3757057
	11 kW	3757058
	15 kW	3757059
	3 kW	3757067
IP55 with: • EMC filter • Inductor • Control panel	4 kW	3757068
	5,5 kW	3757069
	7,5 kW	3757070
	11 kW	3757071
	15 kW	3757072

OPTIONS

MAXIMUM GAS
PRESSURE SWITCH

Description	Output range	Setting range	Code
Kit GPS 150	<15 MW	5 ... 150 mbar	3147771

GAS GOVERNOR WITH
BUILT-IN FILTER

! Default spring is neutral for outlet pressure range 10 - 30 mbar

Size	Maximum gas pressure	Code
Rp1"	500 mbar	3142521
Rp1"1/4	500 mbar	3142522
Rp1"1/2	500 mbar	3142523
Rp2"	500 mbar	3142524
Rp2"	1 bar	3142051
DN65	1 bar	3141983
DN80	1 bar	3142538
DN100	1 bar	on request
DN125	1 bar	on request

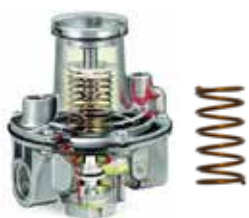
SPRINGS FOR
GAS GOVERNOR

Description	Size	Gas pressure range	Code
Green spring	1/2", 3/4", 1"	5 ... 15 mbar	3142547
Neutral spring		10 ... 30 mbar	3142548
Violet spring		25 ... 80 mbar	3142549
Brown spring		70 ... 160 mbar	3142550
Blue spring		150 ... 280 mbar	3142551
White spring		270 ... 350 mbar	3142552
Green spring	1"1/4, 1"1/2	5 ... 15 mbar	3142553
Neutral spring		10 ... 30 mbar	3142554
Violet spring		20 ... 70 mbar	3142555
Brown spring		65 ... 130 mbar	3142556
White spring		120 ... 250 mbar	3142557
Black spring		240 ... 350 mbar	3142558
Green spring	2"	5 ... 15 mbar	3142559
Neutral spring		10 ... 30 mbar	3142560
Violet spring		30 ... 80 mbar	3142561
Brown spring		70 ... 220 mbar	3142562
Blue spring		210 ... 350 mbar	3142563
Red spring		25-80 mbar	3144252
Violet spring	DN65, DN80	60-120 mbar	3144253
Blue spring		100-220 mbar	3144254
White spring		200-450 mbar	3144255
Red spring	DN100	30-70 mbar	3144256
Violet spring		60-110 mbar	3144257
Brown spring		100-210 mbar	3144258
White spring		200-450 mbar	3144060

OPTIONS**GAS FILTER**

Size	Code
Rp1"	3142046
Rp1"1/2	3141954
Rp2"	3121384
DN65	3124111
DN80	3142088
DN100	3142205
DN125	3142206

ANTIVIBRATION JOINT

Size	Code
Rp1"	3122323
Rp1"1/4	3122324
Rp1"1/2	3122325
Rp2"	3122326
DN65	3142060
DN80	3122328
DN100	3122329
DN125	3142061

MANUAL VALVE

Size	Code
Rp1"	3121430
Rp1"1/4	3142253
Rp1"1/2	3142101
Rp2"	3142102
DN65	3142062
DN80	3143730
DN100	3141997
DN125	3141998

**MANOMETER +
PUSH BUTTON**

Description	Pressure range	Code
Gas manometer 1/2"	0...60 mbar	3142056
Gas manometer 1/4"	0...250 mbar	3142055
Gas manometer 1/4"	0...1000 mbar	3142054
Push button 1/2"		3142057
Push button 1/4"		3142058

OPTIONS

LCM MODULE

Description	Code
LCM module mounted in factory for communication via BUS, O ₂ control and frequency converter	3146795

FREQUENCY CONVERTER ARRANGEMENT

Description	Code
Burner prepared to be connected to an external frequency converter	on request

i This variant includes the VSM module to control the frequency converter

REMOTE SOFTWARE

Description	Code
Kit to connect a PC to the BT300 for its parametrization (LSA100 + USB/CAN + CD-Rom)	3751130

COMMUNICATION MODULES

Description	Code	
Additional module for BT3 (supplied loose)	ModBus/BT3	on request
	ProfiBus/BT3	on request
	Ethernet/BT3	on request

O₂ TRIM

Flue temp max 300 °C
Display for O₂ visualization
The kit includes:

- Lambda transmitter LT3
- Lambda probe LS2
- Probe installation fitting
- Gas extraction device



Additional LSB modules installed at LT3	GED length	Code
None	150 mm	3759296
	300 mm	3759297
	450 mm	3759298
4x 0/4-20 mA output	150 mm	3759299
	300 mm	3759300
	450 mm	3759301
4x 0/4-20 mA output + 4x digital output	150 mm	3759302
	300 mm	3759303
	450 mm	3759304

Description	Code	
Extension for LS2	5m ready-made cable	3759318
	PCB (probe connection box) ¹	3759319

O₂ AND CO TRIM

Flue temp max 300 °C
The kit includes:

- Lambda transmitter LT3-F
- Lambda probe KS1D
- Probe installation fitting
- Gas extraction device

Additional LSB modules installed at LT3-F	GED length	Code
none	150 mm	3759305
	300 mm	3759306
	450 mm	3759307
4x 0/4-20 mA output	150 mm	3759308
	300 mm	3759309
	450 mm	3759310
4x 0/4-20 mA output + 4x digital output	150 mm	3759311
	300 mm	3759312
	450 mm	3759313

Description	Code	
Extension for KS1D	5m ready-made cable	3759318
	PCB (probe connection box) ¹	3759319

! ¹: The PCB is mandatory if the end user chooses to use his own connecting cable and not one of those proposed above
See page 260 for further information

OPTIONS**OIL FILTER**

Description	Suitable for	Code
Oil filter 3/8"	MULTICALOR 70 ... 140	3142085

**OIL SPILL BACK
NOZZLES**

Size (kg/h)	Model	Connection	Code
40			3145231
50			3145232
60			3142763
70			3145233
80			3145234
90			3145235
100			3142704
115			3142564
130			3142515
145			3142516
160			3142421
180			3142492
200			3142690
225			3142489
250			3142768
275			3142805
300			3142490
330			3142703
360			3142513
400			3142497
450			3142483
500			3142699
	Fluidics W2 50°	Threaded, 7/8"	

**KIT FOR AUTOMATIC
FUEL SWITCH GAS/OIL**

Description	Code
Kit automatic fuel switch	3142021

i The standard version works with manual fuel selection mode; with this kit, the change of fuel is activated by a gas pressure switch or by a timer

- MULTICALOR models from 700.1 to 1800.1 are monoblock force-draught burners working with gas or light oil and covering an output range from 1500 to 17000 kW
- These models are available in two stage progressive electronic configuration with Burner Management System
- All models are fully electronically controlled for smooth operation and simple and effective programming operation
- As all the Ecoflam burners they are equipped with an adjustable combustion head for easy regulation and matching with different combustion chambers
- The structure of the burners allow easy access to the internal components for fast start-up and reduced maintenance time and space
- Multiple gas train matching are available according to the inlet gas pressure



WORKING DIAGRAM

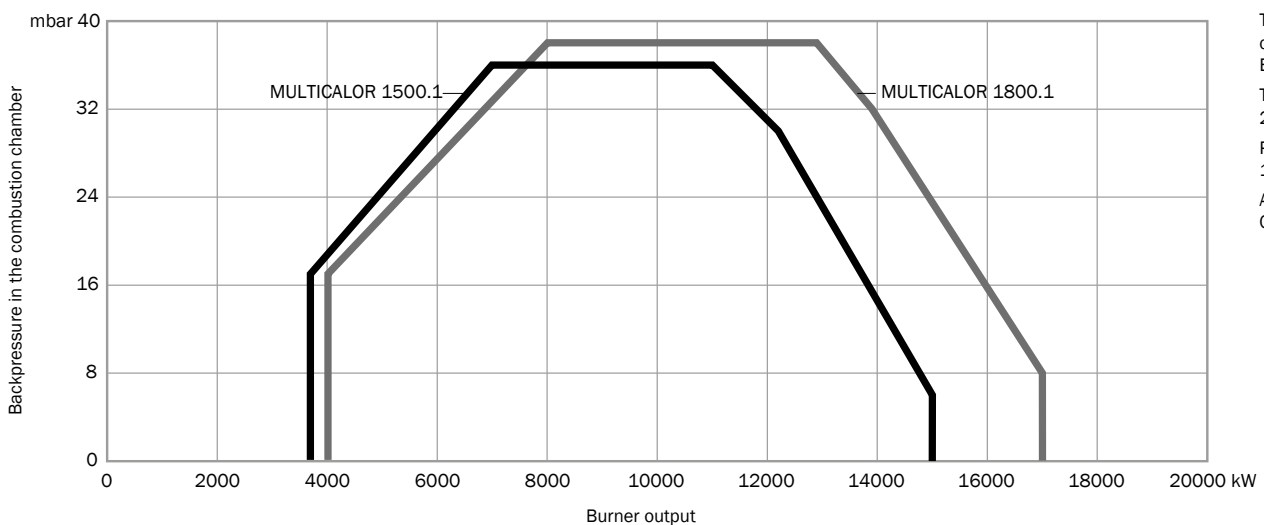
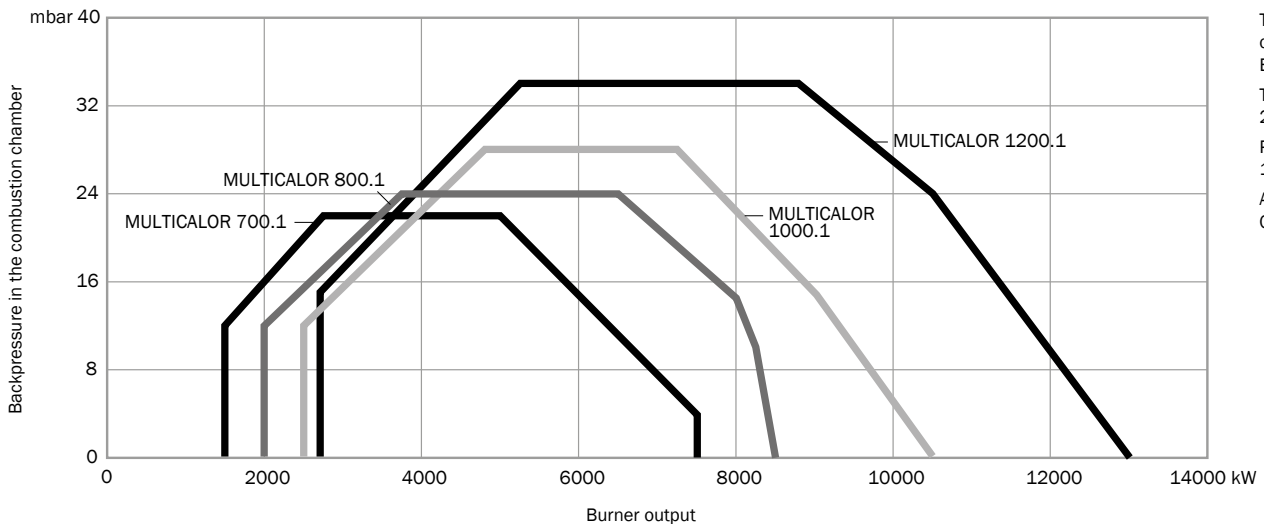

TECHNICAL DATA

Model	Operation	Output (kW)	Flow rate (kg/h)	Control box	Flame detector	Power supply	Motor (kW)	Emissions
MULTICALOR 700.1	PRE	1500 - 7500	126 - 634	BT340	QRA2	3/400/50Hz	15	Class 2 / 1
MULTICALOR 800.1	PRE	2000 - 8500	169 - 718	BT340	QRA2	3/400/50Hz	18,5	Class 2 / 1
MULTICALOR 1000.1	PRE	2500 - 10500	211 - 887	BT340	QRA2	3/400/50Hz	22	Class 2 / 1
MULTICALOR 1200.1	PRE	2700 - 13000	228 - 1099	BT340	QRA2	3/400/50Hz	37	Class 2 / 1
MULTICALOR 1500.1	PRE	3690 - 15000	312 - 1268	BT340	QRA2	3/400/50Hz	45	Class 2 / 1
MULTICALOR 1800.1	PRE	4000 - 17000	338 - 1437	BT340	QRA2	3/400/50Hz	55	Class 2 / 1

CODES

■ PRE - Two stage progressive/modulating electronic in gas and in light oil

Model	TC	TL
MULTICALOR 700.1 PRE	3145152	on request
MULTICALOR 800.1 PRE	3145153	on request
MULTICALOR 1000.1 PRE	3145154	on request
MULTICALOR 1200.1 PRE	3145155	on request
MULTICALOR 1500.1 PRE	3145156	on request
MULTICALOR 1800.1 PRE	3145157	on request

! Nozzle not included in the code of the burner - see page 251

OTHER AVAILABLE CONFIGURATIONS

- Continuous ventilation (CV)
- Post-purge
- 60 Hz
- Special versions on request according to feasibility

i All non-standard configurations are available on request: contact us to know more

OVERALL DIMENSIONS

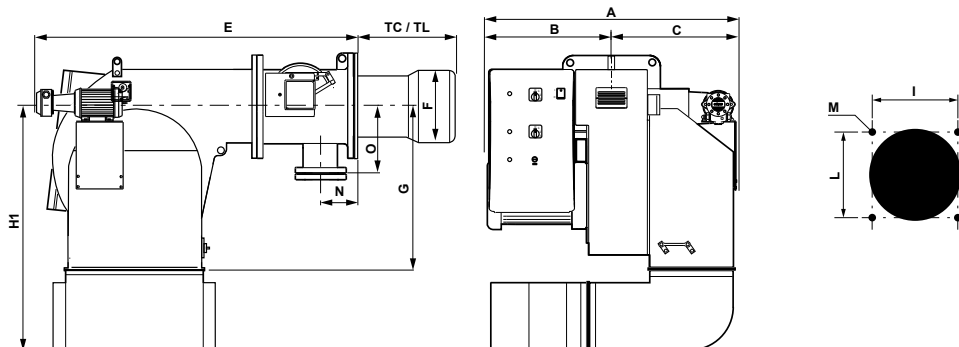

Model	A	B	C	TC	TL	E	F	G	H1 ¹	I	L	M	N	O
MULTICALOR 700.1	1370	740	630	470	-	1640	420	775	1270	460	460	M20	195	232
MULTICALOR 800.1	1370	740	630	470	-	1640	420	775	1270	460	460	M20	195	232
MULTICALOR 1000.1	1370	740	630	470	-	1640	420	775	1270	460	460	M20	195	232
MULTICALOR 1200.1	1430	800	630	470	-	1640	450	775	1270	460	460	M20	195	232

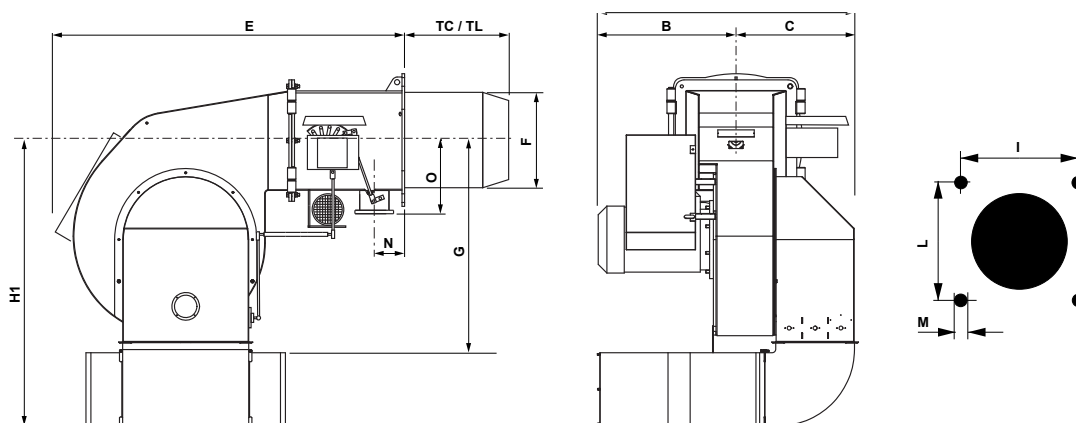

Model	A	B	C	TC	TL	E	F	G	H1 ¹	I	L	M	N	O
MULTICALOR 1500.1	1700	800	900	590	-	1910	550	1320	1670	619	619	M20	210	320
MULTICALOR 1800.1	1770	870	900	590	-	1910	550	1320	1670	619	619	M20	210	320

i Dimensions in mm
Head length: TC short / TL long
¹: with silencer (optional)

PACKAGING

The complete burner with gas train and filter is delivered in a wooden box containing boiler fixing accessories and a bag with technical documentation.

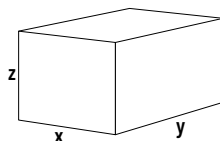

Model	x	y	z	kg
MULTICALOR 700.1	1760	2390	1470	753
MULTICALOR 800.1	1760	2390	1470	830
MULTICALOR 1000.1	1760	2390	1470	908
MULTICALOR 1200.1	1760	2390	1470	908
MULTICALOR 1500.1	2090	2800	1970	1600
MULTICALOR 1800.1	2090	2800	1970	1600

Dimensions in mm.
Values referred to burners in standard version; the dimensions of the package may vary according to the configuration chosen

GAS TRAINS

Model	Pressure (mbar) min - max	Model	Size	Codes	Connection pipe	Filter
for MULTICALOR 700.1	60 - 500	VGD 40.125	DN125	3145823	3145829	3142206
	75 - 500	VGD 40.100	DN100	3145817	3145822	3142205
	140 - 500	VGD 40.080	DN80	3145814	3145816	3142088
	280 - 500	VGD 40.065	DN65	3145793	3145801	3124111
for MULTICALOR 800.1	85 - 500	VGD 40.125	DN125	3145823	3145829	3142206
	110 - 500	VGD 40.100	DN100	3145817	3145822	3142205
	210 - 500	VGD 40.080	DN80	3145814	3145816	3142088
	410 - 500	VGD 40.065	DN65	3145793	3145801	3124111
for MULTICALOR 1000.1	115 - 500	VGD 40.125	DN125	3145823	3145829	3142206
	165 - 500	VGD 40.100	DN100	3145817	3145822	3142205
	290 - 500	VGD 40.080	DN80	3145814	3145816	3142088
	550 - 500	VGD 40.065	DN65	3145793	3145801	3124111
for MULTICALOR 1200.1	175 - 500	VGD 40.125	DN125	3145823	3145829	3142206
	230 - 500	VGD 40.100	DN100	3145817	3145822	3142205
	420 - 500	VGD 40.080	DN80	3145814	3145816	3142088
for MULTICALOR 1500.1	150 - 500	VGD 40.125	DN125	3145823	3145829	3142206
	230 - 500	VGD 40.100	DN100	3145817	3145822	3142205
	450 - 500	VGD 40.080	DN80	3145814	3145816	3142088
for MULTICALOR 1800.1	210 - 500	VGD 40.125	DN125	3145823	3145829	3142206
	330 - 500	VGD 40.100	DN100	3145817	3145822	3142205

- ! Default blank spring: head pressure 0...22 mbar; choose and change spring and damping (to be fitted during installation on site)
 For minimum inlet pressures higher than 250 mbar, choose the pressure switch GW500 (to be fitted during installation on site)
 For gas trains in EN676 Configuration a tightness control device must be included over 1200 kW

GAS TRAINS - DIMENSIONS

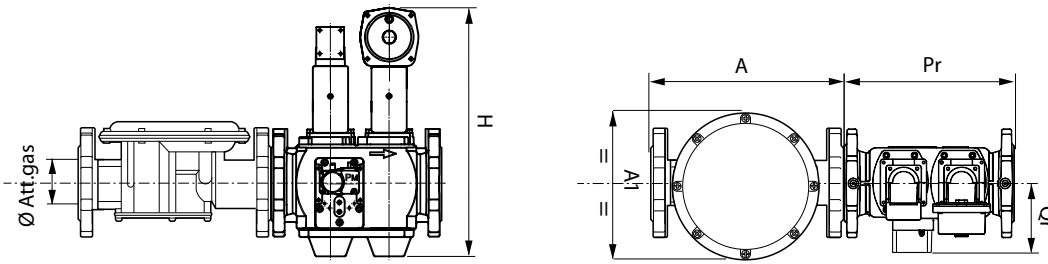

Code	Gas train	\varnothing	Dimensions (mm)		
			Pr	Qr	H
3145793	GT-S1-VGD40-DN65-PS2	DN65	290	127,3	421
3145814	GT-S1-VGD40-DN80-PS2	DN80	310	127,3	445
3145817	GT-S1-VGD40-DN100-PS2	DN100	350	145,4	476
3145823	GT-S1-VGD40-DN125-PS2	DN125	400	158,4	524

CONNECTION PIPE

Code	Dimensions (mm)		
	T	U	V
3145801	202	820	105
3145816	221	820	124
3145822	158	820	158
3145829	284	820	143

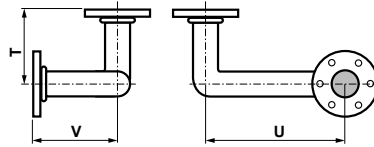

GAS FILTER

Code	\varnothing	Dimensions (mm)	
		A	A1
3124111	DN65	290	212
3142088	DN80	320	240
3142205	DN100	380	280
3142206	DN125	380	280

TOTAL DIMENSIONS CALCULATION

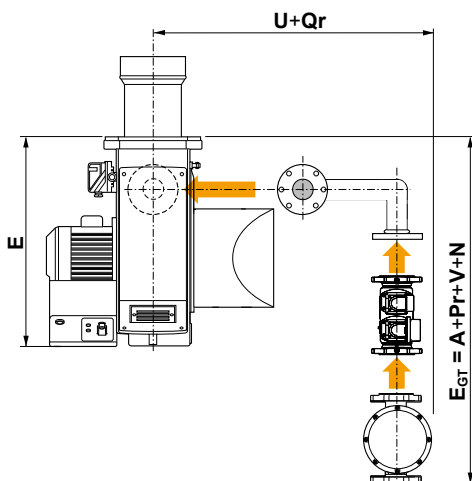

To calculate the overall dimensions, consider the greater value between E and E_{GT}

OPTIONS

MODULATING PID CONTROLLER

Description	Code
Kit RWF50	3143713
Kit RWF55	3143714

i Kit supplied loose; on-board assembly available upon request
See page 257 for more information on RWF kit features

TEMPERATURE AND PRESSURE PROBES



Description	Code
Water probe, temperature range from 0 to 130 °C	3122316
Steam probe 0 ... 2 bar	3124100
Steam probe 0 ... 4 bar	3122317
Steam probe 0 ... 10 bar	3122318
Steam probe 0 ... 16 bar	3122319
Steam probe 0 ... 25 bar	3834314
Steam probe 0 ... 40 bar	3122320
Probe for external temperature from -35° to 50 °C	3122315
Hot air or liquid probe, temperature range from -50° to 400 °C	3122314
Thermocouple J type, temperature up to 750 °C (for RWF55 only)	3146725

FREQUENCY CONVERTER



Description	Code
15 kW	3757059
18,5 kW	3757060
IP21 with:	22 kW
• EMC filter	30 kW
• Inductor	37 kW
• Control panel	45 kW
	55 kW
	15 kW
	18,5 kW
IP55 with:	22 kW
• EMC filter	30 kW
• Inductor	37 kW
• Control panel	45 kW
	55 kW

MAXIMUM GAS PRESSURE SWITCH

Description	Output range	Setting range	Code
Kit GPS 150	<15 MW	5 ... 150 mbar	3147771
Kit GPS 500	>15 MW	50 ... 500 mbar	3147772

GAS GOVERNOR WITH BUILT-IN FILTER

! Default spring is neutral
for outlet pressure range
10 - 30 mbar

Size	Maximum gas pressure	Code
DN65	1 bar	3141983
DN80	1 bar	3142538
DN100	1 bar	on request
DN125	1 bar	on request

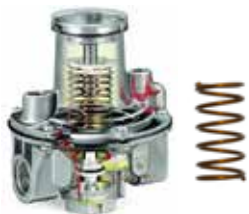
OPTIONS**SPRINGS FOR
GAS GOVERNOR**

Description	Size	Gas pressure range	Code
Red spring	DN65, DN80	25-80 mbar	3144252
Violet spring		60-120 mbar	3144253
Blue spring		100-220 mbar	3144254
White spring		200-450 mbar	3144255
Red spring	DN100	30-70 mbar	3144256
Violet spring		60-110 mbar	3144257
Brown spring		100-210 mbar	3144258
White spring		200-450 mbar	3144060

GAS FILTER

Size	Code
DN65	3124111
DN80	3142088
DN100	3142205
DN125	3142206

ANTIVIBRATION JOINT

Size	Code
DN65	3142060
DN80	3122328
DN100	3122329
DN125	3142061

MANUAL VALVE

Size	Code
DN65	3142062
DN80	3143730
DN100	3141997
DN125	3141998

**MANOMETER +
PUSH BUTTON**

Description	Pressure range	Code
Gas manometer 1/2"	0...60 mbar	3142056
Gas manometer 1/4"	0...250 mbar	3142055
Gas manometer 1/4"	0...1000 mbar	3142054
Push button 1/2"		3142057
Push button 1/4"		3142058

OPTIONS

LCM MODULE

Description	Code
LCM module mounted in factory for communication via BUS, O ₂ control and frequency converter	3146795

FREQUENCY CONVERTER ARRANGEMENT

Description	Code
Burner prepared to be connected to an external frequency converter	on request

i This variant includes the VSM module to control the frequency converter; a LCM module is required and must be added separately

REMOTE SOFTWARE

Description	Code
Kit to connect a PC to the BT300 for its parametrization (LSA100 + USB/CAN + CD-Rom)	3751130

COMMUNICATION MODULES

Description	Code	
Additional module for BT3 (supplied loose)	ModBus/BT3	on request
	ProfiBus/BT3	on request
	Ethernet/BT3	on request

OPTIONS

O₂ TRIM

Flue temp max 300 °C

Display for O₂ visualization

The kit includes:

- Lambda transmitter LT3
- Lambda probe LS2
- Probe installation fitting
- Gas extraction device



Additional LSB modules installed at LT3	GED length	Code
None	150 mm	3759296
	300 mm	3759297
	450 mm	3759298
4x 0/4-20 mA output	150 mm	3759299
	300 mm	3759300
	450 mm	3759301
4x 0/4-20 mA output + 4x digital output	150 mm	3759302
	300 mm	3759303
	450 mm	3759304

Description	Code
Extension for LS2	5m ready-made cable PCB (probe connection box) ¹
	3759318
	3759319

O₂ AND CO TRIM

Flue temp max 300 °C

The kit includes:

- Lambda transmitter LT3-F
- Lambda probe KS1D
- Probe installation fitting
- Gas extraction device

Additional LSB modules installed at LT3-F	GED length	Code
none	150 mm	3759305
	300 mm	3759306
	450 mm	3759307
4x 0/4-20 mA output	150 mm	3759308
	300 mm	3759309
	450 mm	3759310
4x 0/4-20 mA output + 4x digital output	150 mm	3759311
	300 mm	3759312
	450 mm	3759313

Description	Code
Extension for KS1D	5m ready-made cable PCB (probe connection box) ¹
	3759318
	3759319

! ¹: The PCB is mandatory if the end user chooses to use his own connecting cable and not one of those proposed above
See page 260 for further information

OPTIONS**OIL SPILL BACK
NOZZLES**

Size (kg/h)	Model	Connection	Code
300	Fluidics W2 50°	Threaded, 7/8"	3142490
330			3142703
360			3142513
400			3142497
450			3142483
500			3142699
600			3142506
650			3142870
700			3145236

**KIT FOR AUTOMATIC
FUEL SWITCH GAS/OIL**

Description	Code
Kit automatic fuel switch	3142021

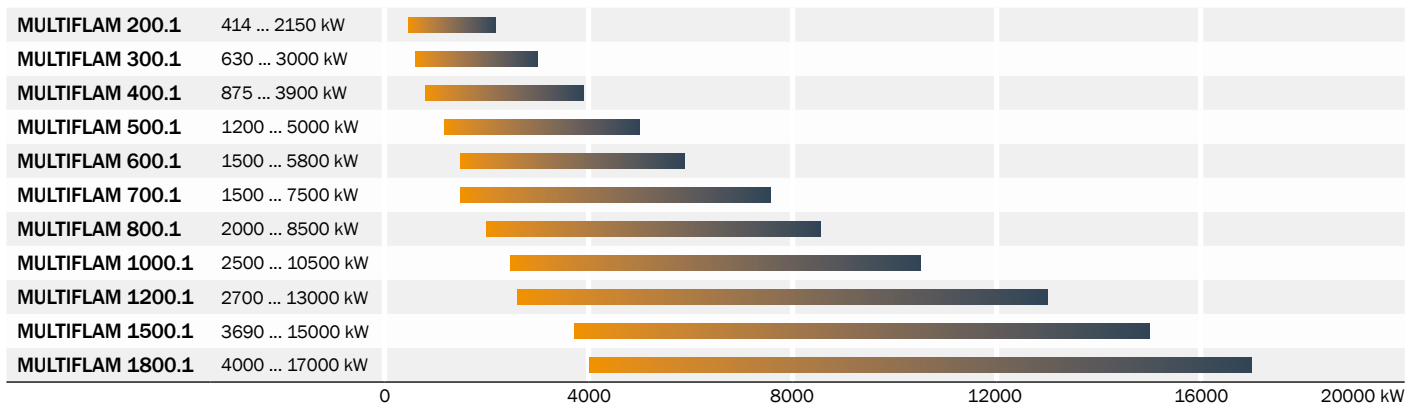

The standard version works with manual fuel selection mode; with this kit, the change of fuel is activated by a gas pressure switch or by a timer

RANGE OVERVIEW**CONFIGURATIONS**

MULTIFLAM range is available in the following operation modes:

**MULTIFLAM 200.1**

Two stages in gas and in heavy oil

**MULTIFLAM 300.1 ... 1800.1 PR**

Two stage progressive/modulating mechanical

**MULTIFLAM 300.1 ... 1800.1 PRE**

Two stage progressive/modulating electronic

Other available configurations:

- Continuous ventilation versions
- High temperature versions
- High viscosity versions suitable for 118 cSt (15° E) at 80° C available on request
- Versions in electronic configuration

MAIN FEATURES

- Two stage version with electric servomotor and integrated system for the regulation of air and fuel (for MULTIFLAM 200.1)
- Progressive version with electric servomotor and double adjustable mechanical cam that allows air and fuel fine tuning
- Modulating version with PID system controller with digital set point display and real time value
- Digital thermoregulator integrated on the front panel to grant temperature stability of the fuel (from MULTIFLAM 300.1)
- Adjustable combustion head for easy regulation and matching with different combustion chambers
- Gas pilot included with separate supply line
- Heavy oil electric heating system on board
- Version with fully electronic Burner Management System available for all models on request
- Configured and special version on request according to feasibility

FUEL

- Natural gas (G20, G25 according to EN676)
- LPG
- Heavy oil (max viscosity 380 cSt (50 °E) at 50 °C)

DIRECTIVES

- All products are built in accordance with the following directives:
- 2006/42/EC Machinery Directive
 - 2014/30/UE EMC Directive
 - 2014/35/UE Low Voltage Directive
 - 2009/142/CEE Gas Appliances Directive

MULTIFLAM
200.1

Two stages in gas and in heavy oil
414 - 2150 kW

MULTIFLAM
400.1 PR

Two stage progressive mechanical
in gas and in heavy oil
875 - 3900 kW

MULTIFLAM
600.1 PR

Two stages in gas and in heavy oil
1500 - 5800 kW

MULTIFLAM
1500.1 PR

Two stage progressive mechanical
in gas and in heavy oil
3690 - 15000 kW



- MULTIFLAM models from 200.1 to 600.1 are monoblock force-draught burners working with gas or heavy oil and covering an output range from 414 to 5800 kW
- Standard versions work with heavy oil with maximum viscosity of 380 cSt (50 °E) at 50 °C; high viscosity versions suitable for 118 cSt (15 °E) at 80 °C are available on request
- MULTIFLAM 200.1 is available in two stages operation; models from 300.1 to 600.1 are available in two stage progressive mechanical operation or modulating with the installation of a power regulator and dedicated probes (see page 257); electronic versions are available on request
- As all the Ecoflam burners they are equipped with an adjustable combustion head for easy regulation and matching with different combustion chambers
- The structure of the burners allow easy access to the internal components for fast start-up and reduced maintenance time and space
- Multiple gas train matching are available according to the inlet gas pressure



WORKING DIAGRAM

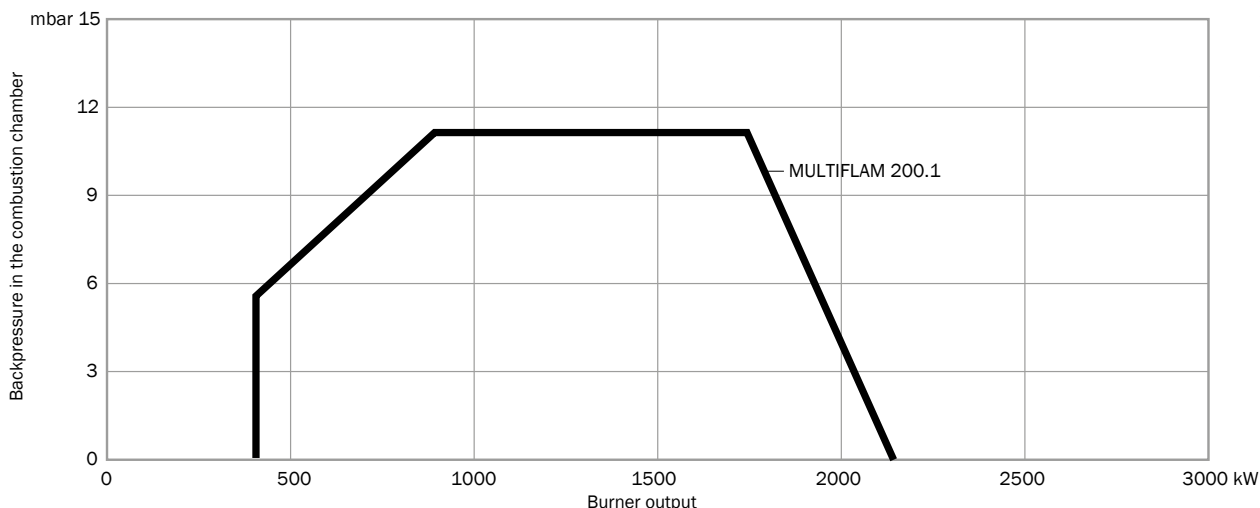

Test conditions conforming to EN676 and EN267
 Temperature: 20 °C
 Pressure: 1013,5 mbar
 Altitude: 0 m a.s.l.

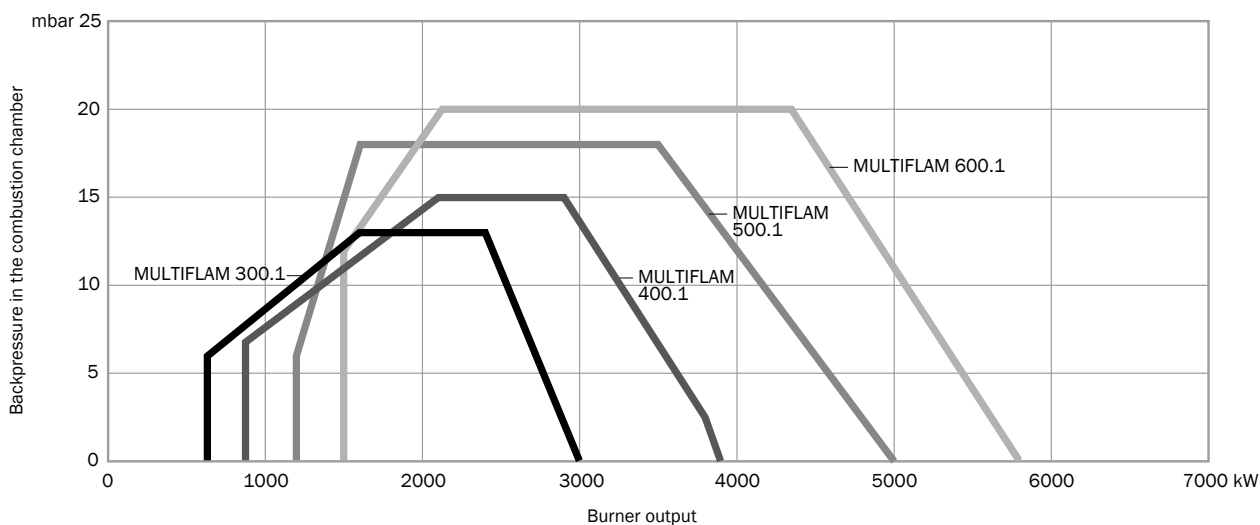

Test conditions conforming to EN676 and EN267
 Temperature: 20 °C
 Pressure: 1013,5 mbar
 Altitude: 0 m a.s.l.

TECHNICAL DATA

Model	Operation	Output (kW)	Flow rate (kg/h)	Control box	Flame detector	Power supply	Motor (kW)	Emissions
MULTIFLAM 200.1	2 stages	414 - 2150	35 - 182	LME22	QRA2	3/230-400/50Hz	4	Class 2 / 1
MULTIFLAM 300.1	PR PRE	630 - 3000	55 - 264	LFL1.333	QRA2	3/400/50Hz	5,5	Class 2 / 1
MULTIFLAM 400.1	PR PRE	875 - 3900	77 - 343	LFL1.333	QRA2	3/400/50Hz	7,5	Class 2 / 1
MULTIFLAM 500.1	PR PRE	1200 - 5000	105 - 440	LFL1.333	QRA2	3/400/50Hz	11	Class 2 / 1
MULTIFLAM 600.1	PR PRE	1500 - 5800	132 - 510	LFL1.333	QRA2	3/400/50Hz	15	Class 2 / 1

CODES

■ PAB - Two stages

Model	TC	TL
MULTIFLAM 200.1	3142669	3142670

■ PR - Two stage progressive/modulating mechanical in gas and in heavy oil

Model	TC	TL
MULTIFLAM 300.1 PR	3143779	3143780
MULTIFLAM 400.1 PR	3143781	3143782
MULTIFLAM 500.1 PR	3143783	3143784
MULTIFLAM 600.1 PR	3143785	3143786

■ P PRE - Two stage progressive/modulating electronic

Codes available on request.
Contact us in case of order.

! Nozzle not included in the code of the burner - see page 251

OTHER AVAILABLE CONFIGURATIONS

- Continuous ventilation (CV)
- Post-purge
- 60 Hz
- High viscosity versions suitable for 118 cSt (15° E) at 80° C
- Special versions on request according to feasibility

i All non-standard configurations are available on request: contact us to know more

OVERALL DIMENSIONS

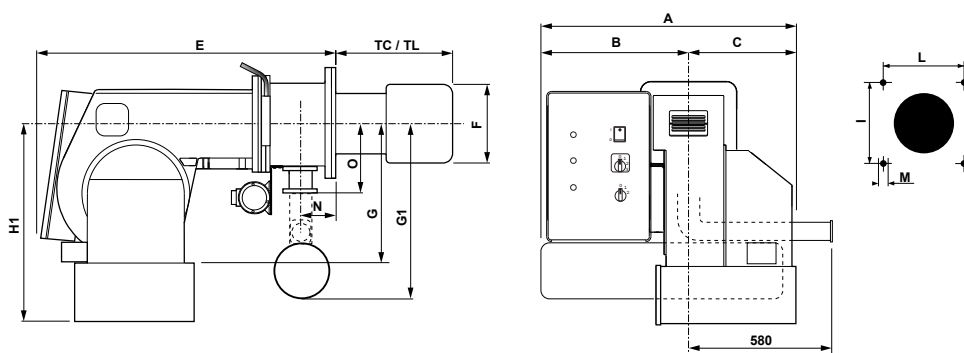

Model	A	B	C	TC	TL	E	F	G	G1	H1 ¹	I	L	M	N	O
MULTIFLAM 200.1	848	530	318	285	485	1150	270	398	600	680	315	315	M14	125	250

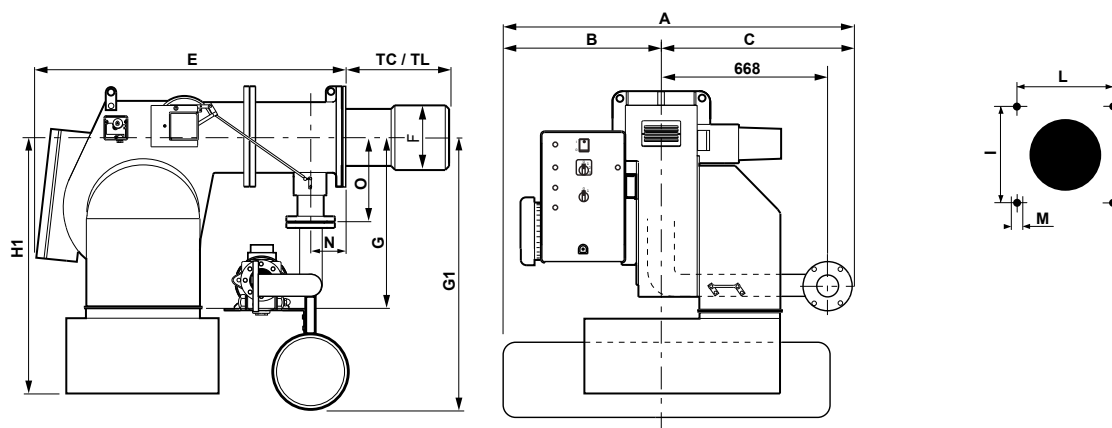

Model	A	B	C	TC	TL	E	F	G	G1	H1 ¹	I	L	M	N	O
MULTIFLAM 300.1	1288	610	678	330	530	1130	290	471	750	746	315	315	M16	195	250
MULTIFLAM 400.1	1288	610	678	330	530	1130	290	471	750	746	315	315	M16	195	250
MULTIFLAM 500.1	1288	610	678	345	545	1130	320	471	750	746	315	315	M16	195	250
MULTIFLAM 600.1	1358	680	678	354	554	1230	320	570	775	965	330	330	M16	195	250

i Dimensions in mm
 Head length: TC short / TL long
¹: with silencer (optional)

PACKAGING

The complete burner with gas train and filter is delivered in a carton box containing boiler fixing accessories and a bag with technical documentation.

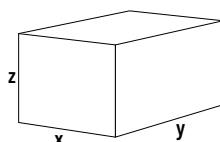

Model	x	y	z	kg
MULTIFLAM 200.1	1590	1590	1080	250
MULTIFLAM 300.1	1590	1590	1080	510
MULTIFLAM 400.1	1590	1590	1080	510
MULTIFLAM 500.1	1760	2390	1470	700
MULTIFLAM 600.1	1760	2390	1470	700

Dimensions in mm.
 Values referred to burners in standard version; the dimensions of the package may vary according to the configuration chosen

GAS TRAINS

Model	Pressure (mbar) min - max	Model	Size	Codes	Connection pipe	Filter
for MULTIFLAM 200.1	35 - 700	VGD 40.080	DN80	3142026	-	3142088
	55 - 700	VGD 40.065	DN65	3124110	3142935	3124111
	100 - 600	VGD 20.503	2"	3123860	3143080	3121384
for MULTIFLAM 300.1	22 - 700	VGD 40.100	DN100	3141869	3142073	3142205
	35 - 700	VGD 40.080	DN80	3142026	-	3142088
	55 - 700	VGD 40.065	DN65	3124110	3142935	3124111
	100 - 600	VGD 20.503	2"	3123860	3143080	3121384
for MULTIFLAM 400.1	30 - 700	VGD 40.100	DN100	3141869	3142073	3142205
	50 - 700	VGD 40.080	DN80	3142026	-	3142088
	90 - 700	VGD 40.065	DN65	3124110	3142935	3124111
	170 - 600	VGD 20.503	2"	3123860	3143080	3121384
for MULTIFLAM 500.1	35 - 700	VGD 40.125	DN125	3142666	3143105	3142206
	45 - 700	VGD 40.100	DN100	3141869	3142073	3142205
	75 - 700	VGD 40.080	DN80	3142026	-	3142088
	140 - 700	VGD 40.065	DN65	3124110	3142935	3124111
	250 - 600	VGD 20.503	2"	3123860	3143080	3121384
for MULTIFLAM 600.1	50 - 700	VGD 40.125	DN125	3142666	3143105	3142206
	60 - 700	VGD 40.100	DN100	3141869	3142073	3142205
	100 - 700	VGD 40.080	DN80	3142026	-	3142088
	180 - 700	VGD 40.065	DN65	3124110	3142935	3124111
	340 - 600	VGD 20.503	2"	3123860	3143080	3121384

- !** Default blank spring: head pressure 0...22 mbar; choose and change spring and damping (to be fitted during installation on site)
For minimum inlet pressures higher than 250 mbar, choose the pressure switch GW500 (to be fitted during installation on site)
For gas trains in EN676 Configuration a tightness control device must be included over 1200 kW

GAS TRAINS - DIMENSIONS

■ VGD 20...

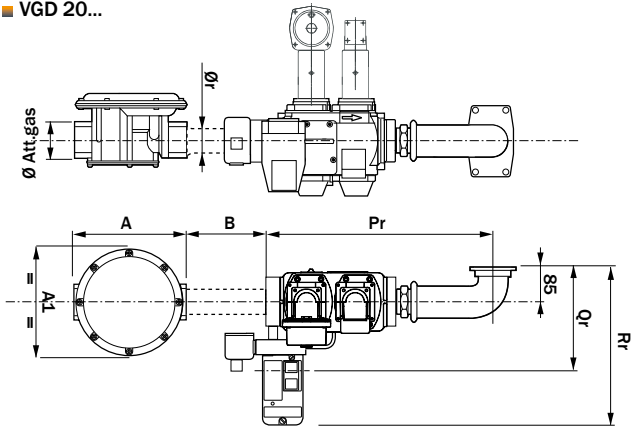

■ VGD 40...

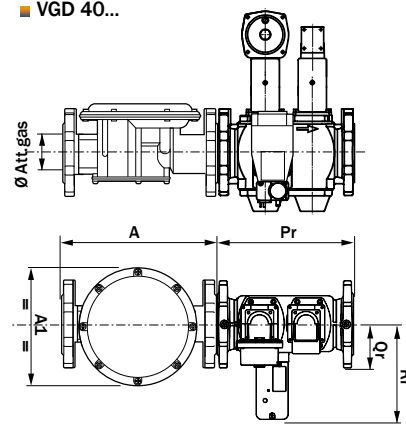

Code	Gas train	Ø	Dimensions (mm)			
			Pr	Qr	Rr	Ør
3123860	GT-S1-VGD20-RP50-BLU/MULTI	Rp2"	450	185	315	Rp2"
3124110	GT-S1-VGD40-DN65-BLU/MULTI	DN65	290	97	211	DN65
3142026	GT-S1-VGD40-DN80-BLU/MULTI	DN80	310	102	218	DN80
3141869	GT-S1-VGD40-DN100-BLU/MULTI	DN100	350	113,5	229	DN100
3142666	GT-S1-VGD40-DN125-BLU/MULTI	DN125	400	127,5	243	DN125

■ CONNECTION PIPE

Code	Pic.	Dimensions (mm)		
		T	U	V
3142073	3	-	130	-
3142935	3	-	120	-
3143080	3	-	80	-
3143105	3	-	137	-

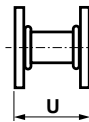

■ GAS FILTER

Code	Ø	Dimensions (mm)		
		A	A1	B
3121384	Rp2"	186	186	>100
3124111	DN65	290	212	-
3142088	DN80	320	240	-
3142205	DN100	380	280	-
3142206	DN125	380	280	-

■ TOTAL DIMENSIONS CALCULATION

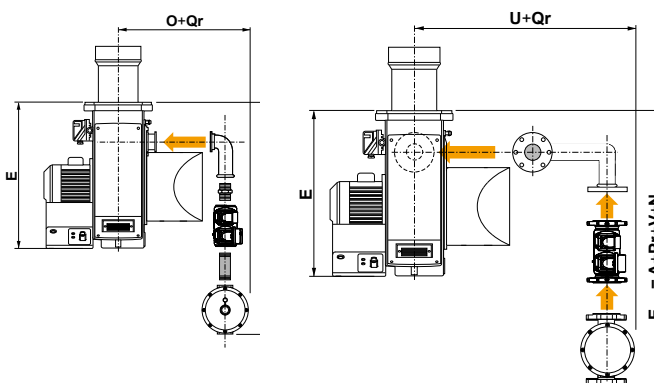

i To calculate the overall dimensions, consider the greater value between E and E_{GT}

OPTIONS

MODULATING
PID CONTROLLER

Description	Code
Kit RWF50	3143713
Kit RWF55	3143714

i Kit supplied loose; on-board assembly available upon request
See page 257 for more information on RWF kit features

TEMPERATURE AND
PRESSURE PROBES

Description	Code
Water probe, temperature range from 0 to 130 °C	3122316
Steam probe 0 ... 2 bar	3124100
Steam probe 0 ... 4 bar	3122317
Steam probe 0 ... 10 bar	3122318
Steam probe 0 ... 16 bar	3122319
Steam probe 0 ... 25 bar	3834314
Steam probe 0 ... 40 bar	3122320
Probe for external temperature from -35° to 50 °C	3122315
Hot air or liquid probe, temperature range from -50° to 400 °C	3122314
Thermocouple J type, temperature up to 750 °C (for RWF55 only)	3146725

CUSTOMER INTERFACE
KIT DISPLAY

Description	Code
Kit display AZL21 for burners equipped with Siemens LME7	3148779

FREQUENCY
CONVERTER

Description	Code	
IP21 with: • EMC filter • Inductor • Control panel	3 kW	3757054
	4 kW	3757055
	5,5 kW	3757056
	7,5 kW	3757057
	11 kW	3757058
	15 kW	3757059
IP55 with: • EMC filter • Inductor • Control panel	3 kW	3757067
	4 kW	3757068
	5,5 kW	3757069
	7,5 kW	3757070
	11 kW	3757071
	15 kW	3757072

TIGHTNESS
CONTROL

For gas trains in EN676
Configuration a tightness
control device must be
included over 1200 kW

Description	Code
Kit VPS504 for MB-DLE/MB-ZRDLE and VGD DN65/80/100 valves, working with natural gas	3122303
Kit VPS504 for VGD20.503 valves, working with natural gas	3122305
Kit VDK for VGD valve, DN125 size	3141922
Kit LDU	3142314
Adaptor for VPS pilot gas train	3142754

OPTIONS

MAXIMUM GAS
PRESSURE SWITCH

Description	Output range	Setting range	Code
Kit GPS 50	<6 MW	5 ... 50 mbar	3141921

GAS GOVERNOR WITH
BUILT-IN FILTER

! Default spring is neutral for outlet pressure range 10 - 30 mbar

Size	Maximum gas pressure	Code
Rp2"	500 mbar	3142524
Rp2"	1 bar	3142051
DN65	1 bar	3141983
DN80	1 bar	3142538
DN100	1 bar	on request
DN125	1 bar	on request

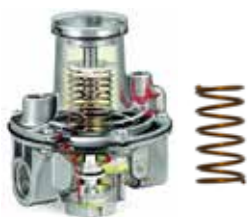
SPRINGS FOR
GAS GOVERNOR

Description	Size	Gas pressure range	Code
Green spring	2"	5 ... 15 mbar	3142559
Neutral spring		10 ... 30 mbar	3142560
Violet spring		30 ... 80 mbar	3142561
Brown spring		70 ... 220 mbar	3142562
Blue spring		210 ... 350 mbar	3142563
Red spring		25-80 mbar	3144252
Violet spring	DN65, DN80	60-120 mbar	3144253
Blue spring		100-220 mbar	3144254
White spring		200-450 mbar	3144255
Red spring	DN100	30-70 mbar	3144256
Violet spring		60-110 mbar	3144257
Brown spring		100-210 mbar	3144258
White spring		200-450 mbar	3144060

GAS FILTER



Size	Code
Rp2"	3121384
DN65	3124111
DN80	3142088
DN100	3142205
DN125	3142206

ANTIVIBRATION JOINT



Size	Code
Rp2"	3122326
DN65	3142060
DN80	3122328
DN100	3122329
DN125	3142061

OPTIONS

OIL SPILL BACK NOZZLES

Size (kg/h)	Model	Connection	Code
300	Bergonzo B5 AA 45 °	Threaded, 7/8"	3142694
400			3142775
425			3142804
450			3142834
500			3142415

! Bergonzo nozzles are recommended for heavy oil burners

KIT FOR AUTOMATIC FUEL SWITCH GAS/OIL

Description	Code
Kit automatic fuel switch	3142021

i The standard version works with manual fuel selection mode; with this kit, the change of fuel is activated by a gas pressure switch or by a timer

SEPARATE PRE-HEATER

Description	Code
Pre-heater unit supplied separately	on request

- MULTIFLAM models from 700.1 to 1800.1 are monoblock force-draught burners working with gas or heavy oil and covering an output range from 1500 to 17000 kW
- Standard versions work with heavy oil with maximum viscosity of 380 cSt (50 °E) at 50 °C; high viscosity versions suitable for 118 cSt (15 °E) at 80 °C are available on request
- These models are available in two stage progressive mechanical operation or modulating with the installation of a power regulator and dedicated probes (see page 257), electronic versions are available on request
- As all the Ecoflam burners they are equipped with an adjustable combustion head for easy regulation and matching with different combustion chambers
- The structure of the burners allow easy access to the internal components for fast start-up and reduced maintenance time and space
- Multiple gas train matching are available according to the inlet gas pressure



WORKING DIAGRAM

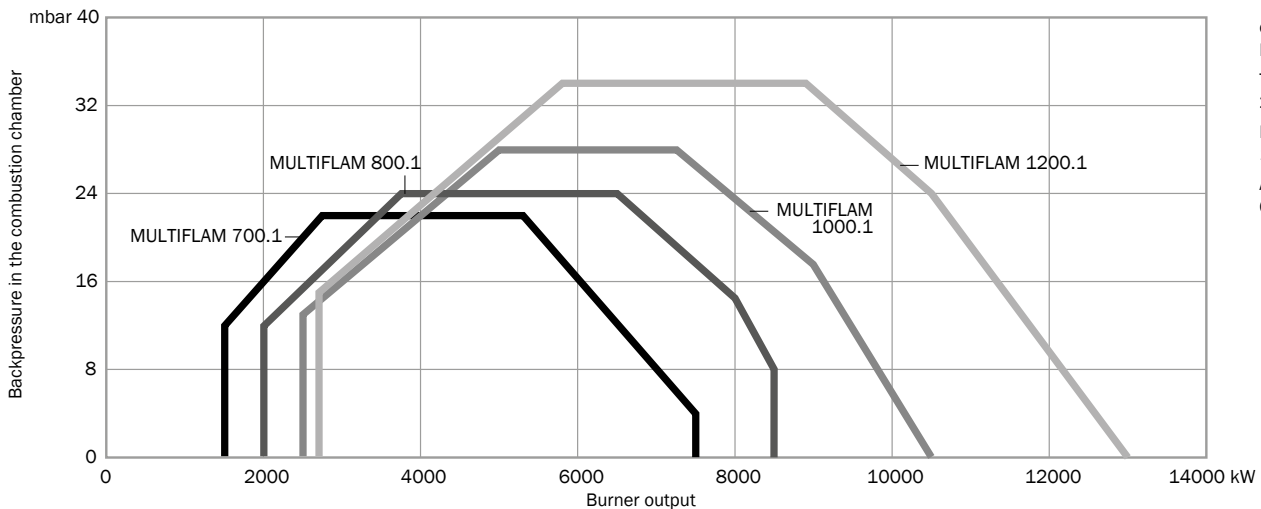

Test conditions conforming to EN676 and EN267
 Temperature: 20 °C
 Pressure: 1013,5 mbar
 Altitude: 0 m a.s.l.

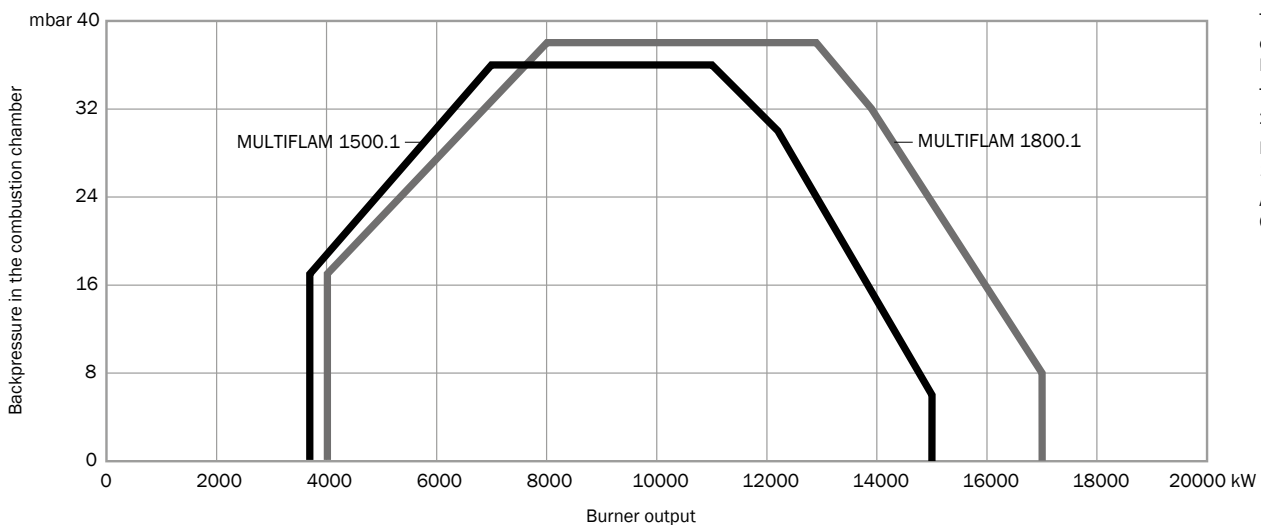

Test conditions conforming to EN676 and EN267
 Temperature: 20 °C
 Pressure: 1013,5 mbar
 Altitude: 0 m a.s.l.

TECHNICAL DATA

Model	Operation	Output (kW)	Flow rate (kg/h)	Control box	Flame detector	Power supply	Motor (kW)	Emissions
MULTIFLAM 700.1	PR PRE	1500 - 7500	132 - 660	LFL1.333	QRA2	3/400/50Hz	15	Class 2 / 1
MULTIFLAM 800.1	PR PRE	2000 - 8500	176 - 748	LFL1.333	QRA2	3/400/50Hz	18,5	Class 2 / 1
MULTIFLAM 1000.1	PR PRE	2500 - 10500	220 - 924	LFL1.333	QRA2	3/400/50Hz	22	Class 2 / 1
MULTIFLAM 1200.1	PR PRE	2700 - 13000	237 - 1143	LFL1.333	QRA2	3/400/50Hz	37	Class 2 / 1
MULTIFLAM 1500.1	PR PRE	3690 - 15000	324 - 1319	LFL1.333	QRA2	3/400/50Hz	45	Class 2 / 1
MULTIFLAM 1800.1	PR PRE	4000 - 17000	352 - 1495	LFL1.333	QRA2	3/400/50Hz	55	Class 2 / 1

CODES

■ PR - Two stage progressive/modulating mechanical in gas and in heavy oil

Model	TC	TL
MULTIFLAM 700.1 PR	on request	on request
MULTIFLAM 800.1 PR	on request	on request
MULTIFLAM 1000.1 PR	on request	on request
MULTIFLAM 1200.1 PR	on request	on request
MULTIFLAM 1500.1 PR	on request	on request
MULTIFLAM 1800.1 PR	on request	on request

■ P PRE - Two stage progressive/modulating electronic

Codes available on request.
Contact us in case of order.

! Nozzle not included in the code of the burner - see page 253

OTHER AVAILABLE CONFIGURATIONS

- Continuous ventilation (CV)
- Post-purge
- 60 Hz
- High viscosity versions suitable for 118 cSt (15 °E) at 80 °C
- Special versions on request according to feasibility

i All non-standard configurations are available on request: contact us to know more

OVERALL DIMENSIONS

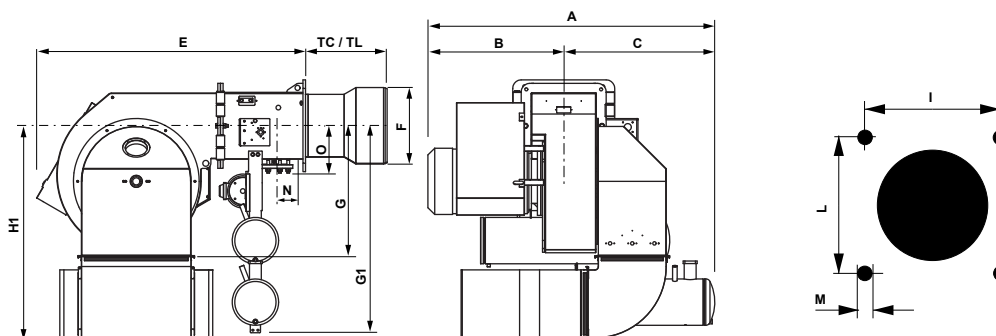

Model	A	B	C	TC	TL	E	F	G	G1	H1 ¹	I	L	M	N	O
MULTIFLAM 700.1	1370	740	630	470	-	1640	420	775	850	1270	195	232	460	460	M20
MULTIFLAM 800.1	1370	740	630	470	-	1640	420	775	850	1270	195	232	460	460	M20
MULTIFLAM 1000.1	1500	740	760	470	-	1640	420	775	850	1270	195	232	460	460	M20
MULTIFLAM 1200.1	1700	800	900	470	-	1640	450	775	1200	1270	195	232	460	460	M20

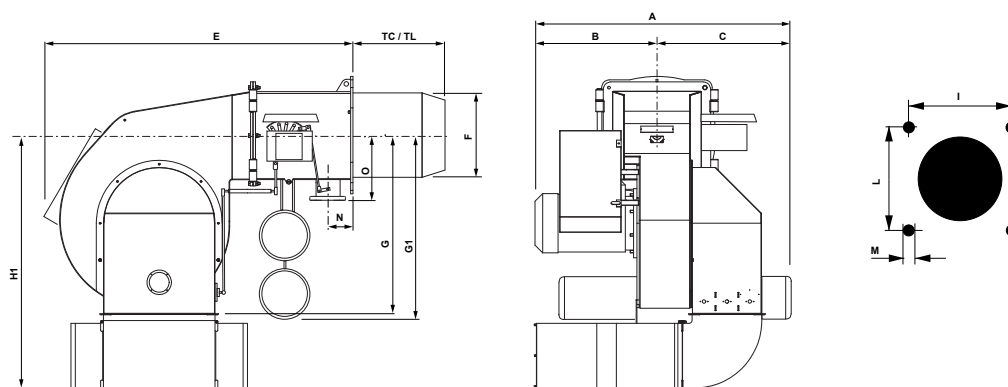

Model	A	B	C	TC	TL	E	F	G	G1	H1 ¹	I	L	M	N	O
MULTIFLAM 1500.1	1700	800	900	590	-	1910	550	1170	1220	1670	210	320	620	620	M20
MULTIFLAM 1800.1	1770	870	900	590	-	1910	550	1170	1220	1670	210	320	620	620	M20

i Dimensions in mm
Head length: TC short / TL long
¹: with silencer (optional)

PACKAGING

The complete burner with gas train and filter is delivered in a wooden box containing boiler fixing accessories and a bag with technical documentation.

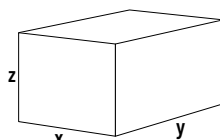

Model	x	y	z	kg
MULTIFLAM 700.1	1760	2390	1470	970
MULTIFLAM 800.1	1760	2390	1470	970
MULTIFLAM 1000.1	2090	2800	1970	1050
MULTIFLAM 1200.1	2090	2800	1970	1500
MULTIFLAM 1500.1	2090	2800	1970	1600
MULTIFLAM 1800.1	2090	2800	1970	1600

Dimensions in mm.
Values referred to burners in standard version; the dimensions of the package may vary according to the configuration chosen

GAS TRAINS

Model	Pressure (mbar) min - max	Model	Size	Codes	Connection pipe	Filter
for MULTIFLAM 700.1	60 - 700	VGD 40.125	DN125	3142666	3145829	3142206
	75 - 700	VGD 40.100	DN100	3141869	3145822	3142205
	140 - 700	VGD 40.080	DN80	3142026	3145816	3142088
	280 - 700	VGD 40.065	DN65	3124110	3145801	3124111
for MULTIFLAM 800.1	85 - 700	VGD 40.125	DN125	3142666	3145829	3142206
	110 - 700	VGD 40.100	DN100	3141869	3145822	3142205
	210 - 700	VGD 40.080	DN80	3142026	3145816	3142088
	410 - 700	VGD 40.065	DN65	3124110	3145801	3124111
for MULTIFLAM 1000.1	115 - 700	VGD 40.125	DN125	3142666	3145829	3142206
	165 - 700	VGD 40.100	DN100	3141869	3145822	3142205
	290 - 700	VGD 40.080	DN80	3142026	3145816	3142088
	550 - 700	VGD 40.065	DN65	3124110	3145801	3124111
for MULTIFLAM 1200.1	160 - 700	VGD 40.150	DN150	on request	on request	on request
	175 - 700	VGD 40.125	DN125	3142666	3145829	3142206
	230 - 700	VGD 40.100	DN100	3141869	3145822	3142205
	420 - 700	VGD 40.080	DN80	3142026	3145816	3142088
for MULTIFLAM 1500.1	125 - 700	VGD 40.125	DN125	on request	on request	on request
	150 - 700	VGD 40.100	DN100	3142666	3145829	3142206
	230 - 700	VGD 40.065	DN65	3141869	3145822	3142205
	450 - 700	VGD 40.080	DN80	3142026	3145816	3142088
for MULTIFLAM 1800.1	175 - 700	VGD 40.150	DN150	on request	on request	on request
	210 - 700	VGD 40.125	DN125	3142666	3145829	3142206
	330 - 700	VGD 40.100	DN100	3141869	3145822	3142205

- !** Default blank spring: head pressure 0...22 mbar; choose and change spring and damping (to be fitted during installation on site)
 For minimum inlet pressures higher than 250 mbar, choose the pressure switch GW500 (to be fitted during installation on site)
 For gas trains in EN676 Configuration a tightness control device must be included over 1200 kW (already included on PRE burners)

GAS TRAINS - DIMENSIONS

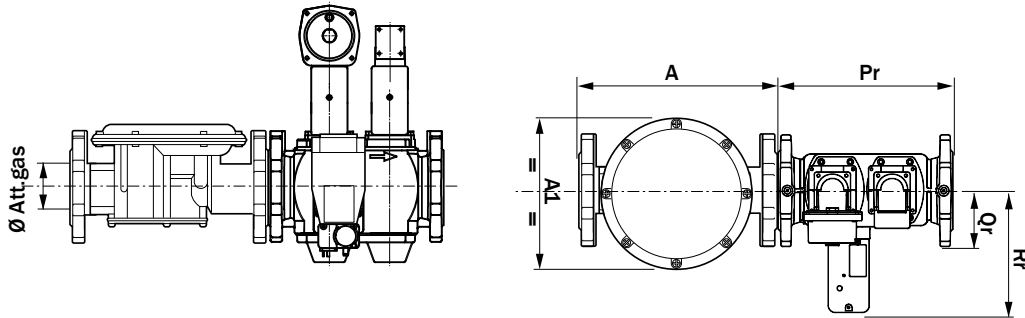

Code	Gas train	\varnothing	Dimensions (mm)			
			Pr	Qr	Rr	$\varnothing r$
3124110	GT-S1-VGD40-DN65-BLU/MULTI	DN65	290	97	211	DN65
3142026	GT-S1-VGD40-DN80-BLU/MULTI	DN80	310	102	218	DN80
3141869	GT-S1-VGD40-DN100-BLU/MULTI	DN100	350	113,5	229	DN100
3142666	GT-S1-VGD40-DN125-BLU/MULTI	DN125	400	127,5	243	DN125

CONNECTION PIPE

Code	Dimensions (mm)		
	T	U	V
3145801	202	820	105
3145816	221	820	124
3145822	158	820	158
3145829	284	820	143

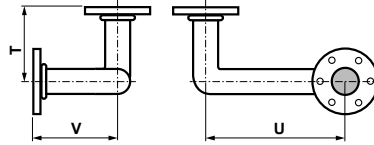

GAS FILTER

Code	\varnothing	Dimensions (mm)	
		A	A1
3124111	DN65	290	212
3142088	DN80	320	240
3142205	DN100	380	280
3142206	DN125	380	280

TOTAL DIMENSIONS CALCULATION

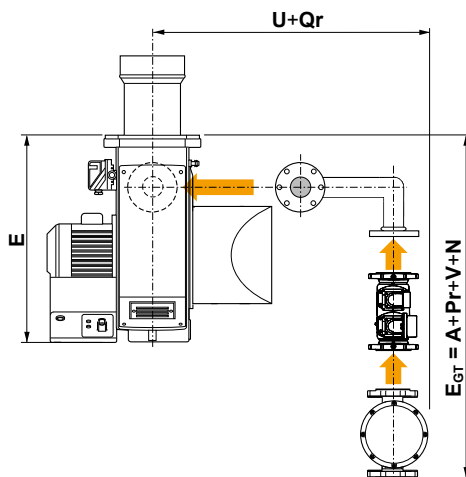

To calculate the overall dimensions, consider the greater value between E and E_{GT}

OPTIONS

MODULATING
PID CONTROLLER

Description	Code
Kit RWF50	3143713
Kit RWF55	3143714

i Kit supplied loose; on-board assembly available upon request
See page 257 for more information on RWF kit features

TEMPERATURE AND
PRESSURE PROBES

Description	Code
Water probe, temperature range from 0 to 130 °C	3122316
Steam probe 0 ... 2 bar	3124100
Steam probe 0 ... 4 bar	3122317
Steam probe 0 ... 10 bar	3122318
Steam probe 0 ... 16 bar	3122319
Steam probe 0 ... 25 bar	3834314
Steam probe 0 ... 40 bar	3122320
Probe for external temperature from -35° to 50 °C	3122315
Hot air or liquid probe, temperature range from -50° to 400 °C	3122314
Thermocouple J type, temperature up to 750 °C (for RWF55 only)	3146725

CUSTOMER INTERFACE
KIT DISPLAY

Description	Code
Kit display AZL21 for burners equipped with Siemens LME7	3148779

FREQUENCY
CONVERTER

Description	Code	
IP21 with: • EMC filter • Inductor • Control panel	15 kW	3757059
	18,5 kW	3757060
	22 kW	3757061
	30 kW	3757062
	37 kW	3757063
	45 kW	3757064
	55 kW	3757065
	15 kW	3757072
	18,5 kW	3757073
	22 kW	3757074
IP55 with: • EMC filter • Inductor • Control panel	30 kW	3757075
	37 kW	3757076
	45 kW	3757077
	55 kW	3757078

TIGHTNESS
CONTROL

! For gas trains in EN676
Configuration a tightness
control device must be
included over 1200 kW

Description	Code
Kit VPS504 for VGD DN65/80/100 valves, working with natural gas	3122303
Kit VDK for VGD valves, DN125 size	3141922
Kit LDU	3142314
Adaptor for VPS pilot gas train	3142754

OPTIONS

MAXIMUM GAS
PRESSURE SWITCH

Description	Output range	Setting range	Code
Kit GPS 150	6 ... 15 MW	30 ... 150 mbar	3142033
Kit GPS 500	>15 MW	50 ... 500 mbar	3145166

GAS GOVERNOR WITH
BUILT-IN FILTER

! Default spring is neutral
for outlet pressure range
10 - 30 mbar

Size	Maximum gas pressure	Code
DN65	1 bar	3141983
DN80	1 bar	3142538
DN100	1 bar	on request
DN125	1 bar	on request

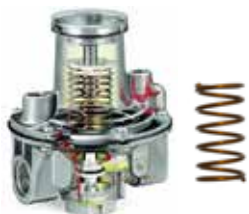
SPRINGS FOR
GAS GOVERNOR

Description	Size	Gas pressure range	Code
Red spring	DN65, DN80	25-80 mbar	3144252
Violet spring		60-120 mbar	3144253
Blue spring		100-220 mbar	3144254
White spring		200-450 mbar	3144255
Red spring	DN100	30-70 mbar	3144256
Violet spring		60-110 mbar	3144257
Brown spring		100-210 mbar	3144258
White spring		200-450 mbar	3144060

GAS FILTER



Size	Code
DN65	3124111
DN80	3142088
DN100	3142205
DN125	3142206
DN150	3142808

ANTIVIBRATION JOINT



Size	Code
DN65	3142060
DN80	3122328
DN100	3122329
DN125	3142061
DN150	3147792

OPTIONS

OIL SPILL BACK
NOZZLES

Size (kg/h)	Model	Connection	Code
300	Bergonzo B5 AA 45°	Threaded, 7/8"	3142694
400			3142775
425			3142804
450			3142834
500			3142415
600			3141837
650			3144394
700			3142948
750			3142491
800			3142833
850			3145237
900			3142510
950			3145238
1000			3142947
1100 - A (for models from 700.1 to 1200.1)	Bergonzo C5 45°	Threaded, M35x1/2"	3142949
1000 - B (for models 1500.1 and 1800.1)			3142961
1100			3142769
1200			3144774
1300			3144490
1400			3142776
1500			3145239

! Bergonzo nozzles are recommended for heavy oil burners

KIT FOR AUTOMATIC
FUEL SWITCH GAS/OIL

Description	Code
Kit automatic fuel switch	3142021

i The standard version works with manual fuel selection mode; with this kit, the change of fuel is activated by a gas pressure switch or by a timer

SEPARATE
PRE-HEATER

Description	Code
Pre-heater unit supplied separately	on request

Thanks to their extreme flexibility and ease of use TS burners are suitable for all types of installation up to 42 MW. Burners can be assembled with air duct connection in different layouts in order to meet a wide range of specifications in terms of performance and overall dimensions. All the models of the range can work with pre-heated combustion air up to 200 °C; **HT2.2 versions** suitable to work with temperature up to 250 °C in order to achieve greater values of efficiency are also available.

RANGE OVERVIEW

! The following diagrams make reference to burners in standard configuration. For HT versions it is necessary to consider a reduction in the power range which depends on the chosen configuration and the combustion air temperature.

GAS

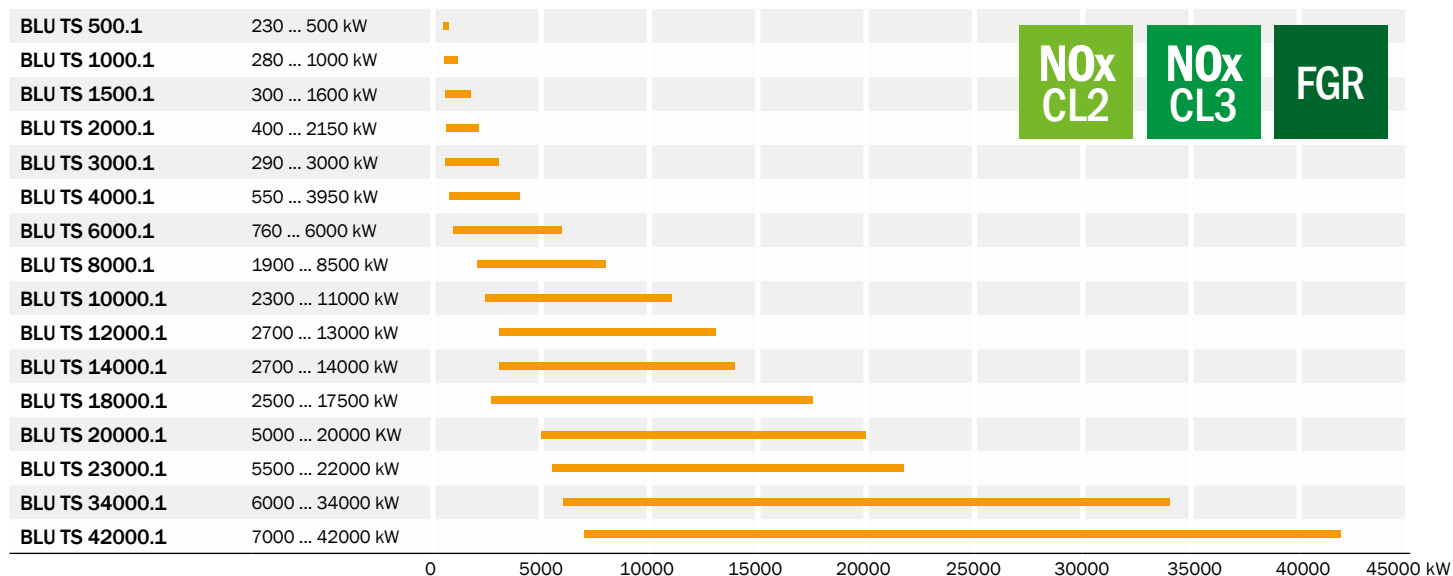

LIGHT OIL

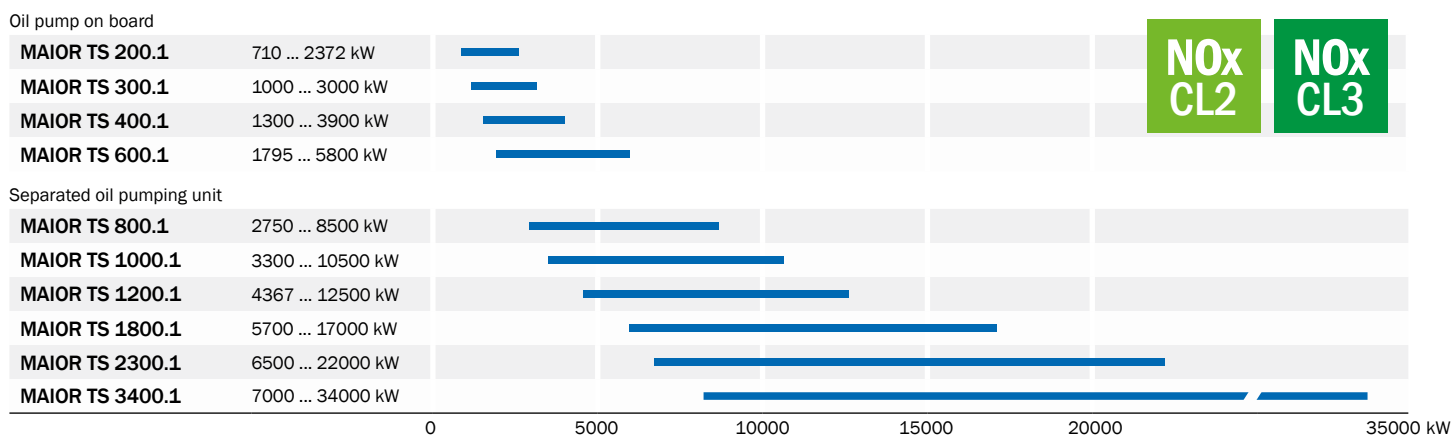

HEAVY OIL

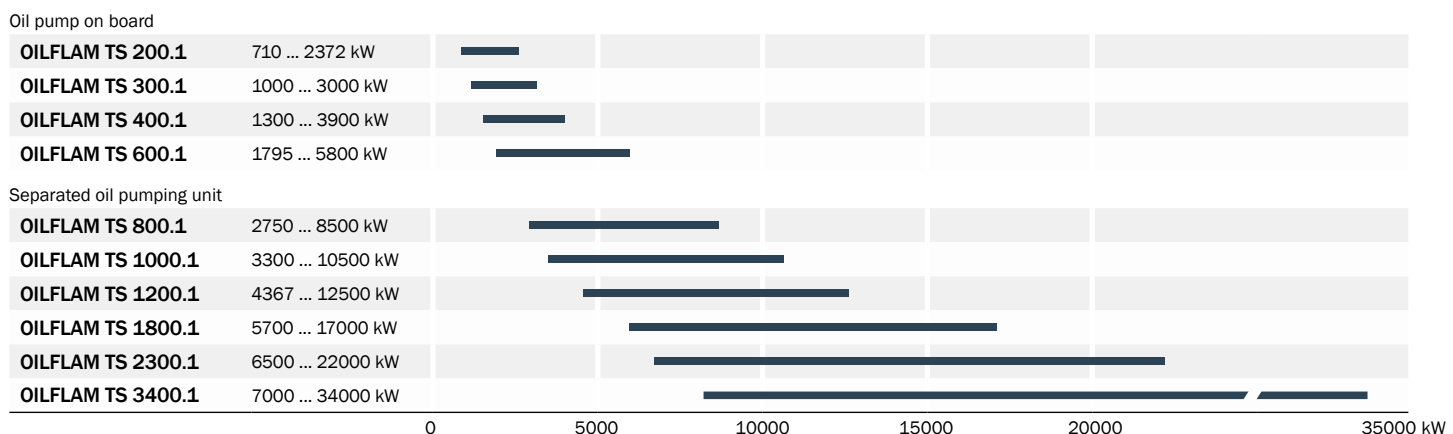



DUAL FUEL (GAS/LIGHT OIL)

Oil pump on board

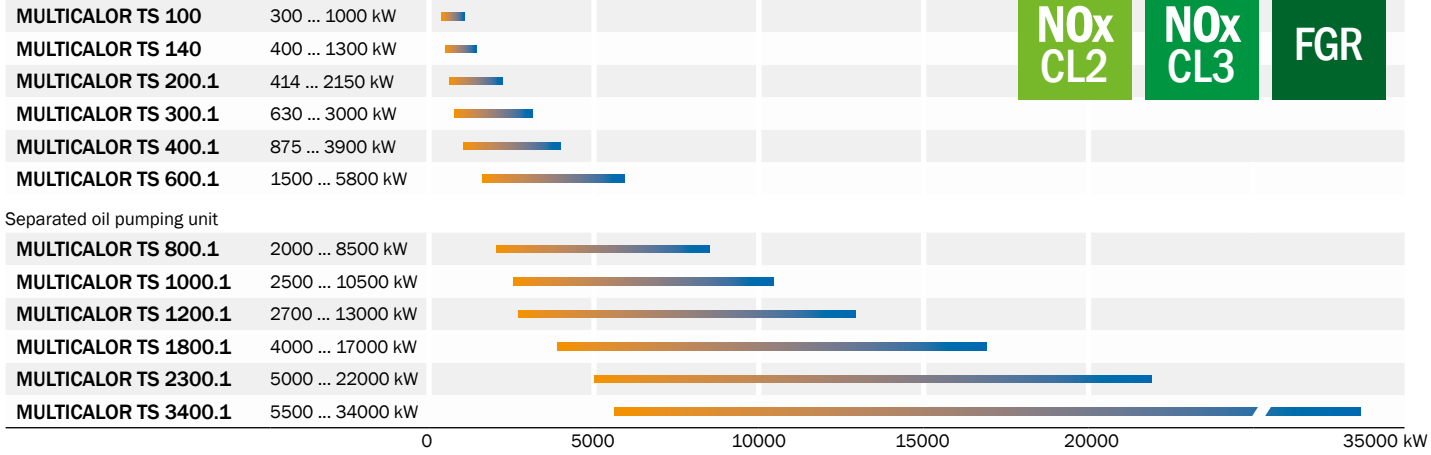

DUAL FUEL (GAS/HEAVY OIL)

Oil pump on board

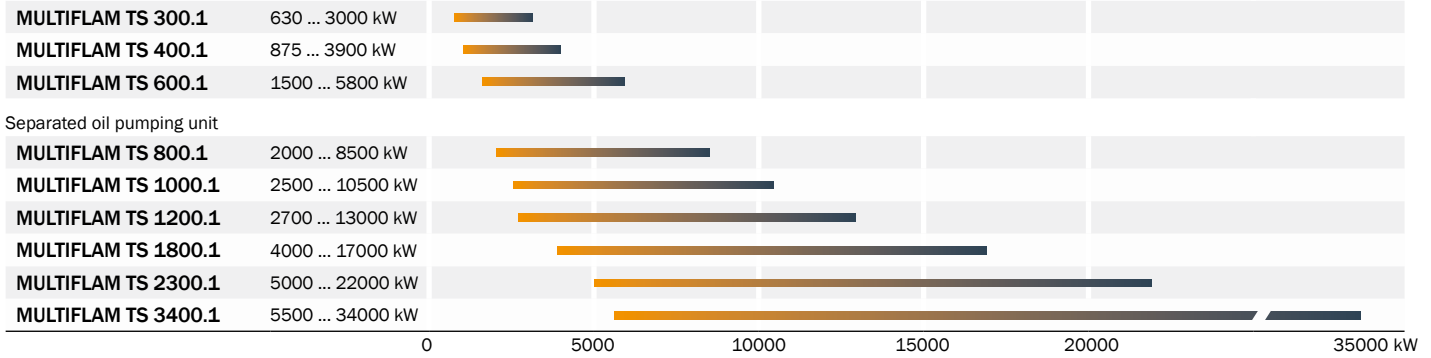

CONFIGURATIONS

TS burners are available in the following operation modes:



Models up to 2 MW
Two stages



Models up to 42 MW
Two stage progressive/modulating mechanical



Models up to 42 MW
Two stage progressive/modulating electronic

TS series is available in a wide range of variants to suit any application or specific requirement. Contact us to know more.

MAIN FEATURES

All the benefits of the separate ventilation

In contrast to monoblock burners, duoblock burners are made up of two units, or blocks, as the name implies: the burner head with the air inlet, and the separately-installed fan; the two units are connected via an air duct.

The separate installation of the fan offers several benefits:

- the fan can be installed in a separate room, for instance in the cellar; this results in considerably lower noise levels in the boiler room; when the fan is installed in the same room, a fan enclosure can be used to achieve optimum sound absorption, without inhibiting access to the burner;
- less space required in front of the boiler and in the boiler room;
- individual fan layout with optimum adaptation of the fan characteristic curve to suit the pressure ratio of the heat generator; this guarantees pulsation-free and stable burner behaviour, even on heat generators with high resistance on the exhaust side;
- combustion air can be pre-heated to increase installation efficiency;
- lower weight loading on the boiler front.

Maximum flexibility for highly customized solutions

Thanks to their extreme flexibility and ease of use TS burners are suitable for all types of installation from 200 kW up to 42 MW. Terminal block configuration is provided as standard; versions with integrated control panel are available on request.



Burners can be assembled with air duct connection in different layouts in order to meet a wide range of specifications in terms of performance and overall dimensions.

Low maintenance, high reliability

All TS range models feature easy maintenance. Access to the combustion head and to the internal components is allowed from the housing top cover with a single operation, without removing the burner from the boiler.

The clear layout allows rapid cleaning of the mechanical components, keeping the installation always in good conditions.



HT2.2

All TS models can work with pre-heated combustion air up to 200 °C. High temperature "HT2.2" versions suitable to work with pre-heated combustion air up to 250 °C in order to achieve greater values of efficiency.

The burners are equipped with:

- external thermal screen protection
- insulated removable upper covers
- servomotors with heat insulation and plastic support
- metallic sheath cables
- integrated control panel

CONFIGURATIONS, VARIANTS AND ACCESSORIES



■ Standard configuration:
 loose version with
 derivative panel



■ IP55 Switch cabinet configuration:
 version with assembled or
 remote switch cabinet



■ Pre-heating
 pump station



■ Separate ventilator



■ Gas train unit



■ Modulation Kit



■ Gas governor/filter
 (Compulsory EN676)



■ Max pressure switch



■ Tightness control
 (Compulsory EN676
 over 1200 kW)

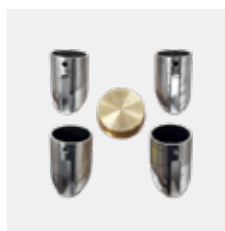

■ LPG/Natural gas

- Fuel: natural gas
- Operation: two stages and two stage progressive or modulating with the installation of a power regulator and dedicated probes (see page 257)
- Emission class: Low NOx class 2 (≤ 120 mg/kWh) according to EN676
- Max inlet air temperature: 200 °C (versions suitable to work with higher temperature available on request)

■ Two stages, terminal box with burner control unit supplied loose

Model	TC	TM	TL
BLU TS 1000.1 PAB HT2	3147352	3147353	3147354
BLU TS 2000.1 PAB HT2	3147355	3147356	3147357

■ Two stage progressive/modulating mechanical, terminal box with burner control unit supplied loose

Model	TC	TM	TL
BLU TS 2000.1 PR HT2	3147358	3147359	3147360
BLU TS 3000.1 PR HT2	3147361	3147362	3147363
BLU TS 4000.1 PR HT2	3147364	3147365	3147366
BLU TS 6000.1 PR HT2	3147367	3147368	3147369
BLU TS 8000.1 PR HT2	3147370	3147371	3147372
BLU TS 10000.1 PR HT2	3147373	3147374	3147375
BLU TS 12000.1 PR HT2	3147376	3147377	3147378
BLU TS 18000.1 PR HT2	3147382	3147383	3147384

HT2.2

HT2.2 versions, suitable to work with pre-heated combustion air **up to 250 °C**, are available on request according to feasibility

- Fuel: natural gas
- Operation: two stage progressive or modulating with the installation of a power regulator and dedicated probes (see page 257)
- Emission class: Low NOx class 3 (≤ 80 mg/kWh) according to EN676
- Max inlet air temperature: 200 °C (versions suitable to work with higher temperature available on request)
- Versions equipped with FGR System to reach NOx emission below 30 mg/kWh available on request



■ Two stage progressive/modulating electronic (Etamatic OEM, terminal box with burner control unit and customer interface supplied loose)

Model	TC	TM	TL
BLU TS 500.1 LN PRE HT2	3147520	3147521	3147522
BLU TS 1000.1 LN PRE HT2	3147523	3147524	3147525
BLU TS 1500.1 LN PRE HT2	3147526	3147527	3147528
BLU TS 2000.1 LN PRE HT2	3147529	3147530	3147531
BLU TS 3000.1 LN PRE HT2	3147532	3147533	3147534
BLU TS 4000.1 LN PRE HT2	3147535	3147536	3147537
BLU TS 6000.1 LN PRE HT2	3147538	3147539	3147540
BLU TS 8000.1 LN PRE HT2	on request	on request	on request
BLU TS 10000.1 LN PRE HT2	3147544	3147545	3147546
BLU TS 12000.1 LN PRE HT2	3147547	3147548	3147549
BLU TS 14000.1 LN PRE HT2	on request	on request	on request
BLU TS 18000.1 LN PRE HT2	3147553	3147554	3147555
BLU TS 20000.1 LN PRE HT2	on request	on request	on request
BLU TS 23000.1 LN PRE HT2	3147556	3147557	3147558
BLU TS 34000.1 LN PRE HT2	3147559	3147560	3147561
BLU TS 42000.1 LN PRE HT2	on request	on request	on request

■ Two stage progressive/modulating electronic (BT300, burner control unit included in the burner switch cabinet)

Model	TC	TM	TL
BLU TS 500.1 LN PRE HT2 BT3	3147320	3147321	3147322
BLU TS 1000.1 LN PRE HT2 BT3	3147323	3147324	3147325
BLU TS 1500.1 LN PRE HT2 BT3	3147326	3147327	3147328
BLU TS 2000.1 LN PRE HT2 BT3	3147329	3147330	3147331
BLU TS 3000.1 LN PRE HT2 BT3	3147332	3147333	3147334
BLU TS 4000.1 LN PRE HT2 BT3	3147335	3147336	3147337
BLU TS 6000.1 LN PRE HT2 BT3	3147338	3147339	3147340
BLU TS 8000.1 LN PRE HT2 BT3	on request	on request	4384120
BLU TS 10000.1 LN PRE HT2 BT3	3147344	3147345	3147346
BLU TS 12000.1 LN PRE HT2 BT3	3147347	3147348	3147349
BLU TS 14000.1 LN PRE HT2 BT3	on request	on request	4384137

! Maximum length of the control unit from the burner: 10 mt



HT2.2 versions, suitable to work with pre-heated combustion air up to 250 °C, are available on request according to feasibility

- Fuel: light oil an heavy oil
- Operation: two stages and two stage progressive or modulating with the installation of a power regulator and dedicated probes (see page 257)
- Max inlet air temperature: 200 °C (versions suitable to work with higher temperature available on request)

■ LIGHT OIL range

■ Two stages

Model	TC	TL
MAIOR TS 200.1 AB HT2	on request	on request

■ Two stage progressive/modulating mechanical

Model	TC	TL
MAIOR TS 200.1 PR HT2	on request	on request
MAIOR TS 300.1 PR HT2	on request	on request
MAIOR TS 400.1 PR HT2	on request	on request
MAIOR TS 600.1 PR HT2	on request	on request
MAIOR TS 800.1 PR HT2	on request	on request
MAIOR TS 1000.1 PR HT2	on request	on request
MAIOR TS 1200.1 PR HT2	on request	on request
MAIOR TS 1800.1 PR HT2	on request	on request
MAIOR TS 2300.1 PR HT2	on request	on request
MAIOR TS 3400.1 PR HT2	on request	on request

■ Two stage progressive/modulating electrical (Etamatic OEM or BT3)

Model	TC	TL
MAIOR TS 200.1 PRE HT2	on request	on request
MAIOR TS 300.1 PRE HT2	on request	on request
MAIOR TS 400.1 PRE HT2	on request	on request
MAIOR TS 600.1 PRE HT2	on request	on request
MAIOR TS 800.1 PRE HT2	on request	on request
MAIOR TS 1000.1 PRE HT2	on request	on request
MAIOR TS 1200.1 PRE HT2	on request	on request
MAIOR TS 1800.1 PRE HT2	on request	on request
MAIOR TS 2300.1 PRE HT2	on request	on request
MAIOR TS 3400.1 PRE HT2	on request	on request

■ HEAVY OIL range

■ Two stage progressive/modulating electrical (Etamatic OEM or BT3)

Model	TC	TL
OILFLAM TS 200.1 PRE HT2	on request	on request
OILFLAM TS 300.1 PRE HT2	on request	on request
OILFLAM TS 400.1 PRE HT2	on request	on request
OILFLAM TS 600.1 PRE HT2	on request	on request
OILFLAM TS 800.1 PRE HT2	on request	on request
OILFLAM TS 1000.1 PRE HT2	on request	on request
OILFLAM TS 1200.1 PRE HT2	on request	on request
OILFLAM TS 1800.1 PRE HT2	on request	on request
OILFLAM TS 2300.1 PRE HT2	on request	on request
OILFLAM TS 3400.1 PRE HT2	on request	on request

LOW NOx

Low NOx versions available on request

HT2.2

HT2.2 versions, suitable to work with pre-heated combustion air **up to 250 °C**, are available on request according to feasibility

i

Burner supplied with terminal block with burner controller in a separate box

Oil pump on board up to MAIOR TS 600.1; separated oil pumping unit (not included in the scope of supply) starting from MAIOR TS 800.1

Nozzle not included in the code of the burner See "Oil spill back nozzles" section at page 253

HT2.2

HT2.2 versions, suitable to work with pre-heated combustion air **up to 250 °C**, are available on request according to feasibility

i

Burner supplied with terminal block with burner controller in a separate box

Oil pump on board up to OILFLAM TS 600.1; separated oil pumping unit (not included in the scope of supply) starting from MAIOR TS 800.1

Nozzle not included in the code of the burner See "Oil spill back nozzles" section at page 253

- Fuel: natural gas and light oil or heavy oil
- Operation: two stages and two stage progressive or modulating with the installation of a power regulator and dedicated probes (see page 257)
- Max inlet air temperature: up to 200 °C with additional equipment (versions suitable to work with higher temperature available on request)

■ DUAL FUEL (GAS/LIGHT OIL) range

■ Two stages

Model	TC	TL
MULTICALOR TS 100 PAB HT2	on request	on request
MULTICALOR TS 140 PAB HT2	on request	on request
MULTICALOR TS 200.1 PAB HT2	on request	on request



Low NOx and ULTRA Low NOx versions available on request



HT2.2 versions, suitable to work with pre-heated combustion air up to 250 °C, are available on request according to feasibility

■ Two stage progressive/modulating mechanical

Model	TC	TL
MULTICALOR TS 200.1 PR HT2	on request	on request
MULTICALOR TS 300.1 PR HT2	on request	on request
MULTICALOR TS 400.1 PR HT2	on request	on request
MULTICALOR TS 600.1 PR HT2	on request	on request
MULTICALOR TS 800.1 PR HT2	on request	on request
MULTICALOR TS 1000.1 PR HT2	on request	on request
MULTICALOR TS 1200.1 PR HT2	on request	on request
MULTICALOR TS 1800.1 PR HT2	on request	on request
MULTICALOR TS 2300.1 PR HT2	on request	on request
MULTICALOR TS 3400.1 PR HT2	on request	on request

i Burner supplied with terminal block with burner controller in a separate box

Oil pump on board up to MULTICALOR TS 600.1; separated oil pumping unit (not included in the scope of supply) starting from MULTICALOR TS 800.1

Nozzle not included in the code of the burner
 See "Oil spill back nozzles" section at page 253

■ Two stage progressive/modulating electrical (Etamatic OEM or BT3)

Model	TC	TL
MULTICALOR TS 200.1 PRE HT2	on request	on request
MULTICALOR TS 300.1 PRE HT2	on request	on request
MULTICALOR TS 400.1 PRE HT2	on request	on request
MULTICALOR TS 600.1 PRE HT2	on request	on request
MULTICALOR TS 800.1 PRE HT2	on request	on request
MULTICALOR TS 1000.1 PRE HT2	on request	on request
MULTICALOR TS 1200.1 PRE HT2	on request	on request
MULTICALOR TS 1800.1 PRE HT2	on request	on request
MULTICALOR TS 2300.1 PRE HT2	on request	on request
MULTICALOR TS 3400.1 PRE HT2	on request	on request

■ DUAL FUEL (GAS/HEAVY OIL) range

■ Two stage progressive/modulating electrical (Etamatic OEM or BT3)

Model	TC	TL
MULTIFLAM TS 200.1 PRE HT2	on request	on request
MULTIFLAM TS 300.1 PRE HT2	on request	on request
MULTIFLAM TS 400.1 PRE HT2	on request	on request
MULTIFLAM TS 600.1 PRE HT2	on request	on request
MULTIFLAM TS 800.1 PRE HT2	on request	on request
MULTIFLAM TS 1000.1 PRE HT2	on request	on request
MULTIFLAM TS 1200.1 PRE HT2	on request	on request
MULTIFLAM TS 1800.1 PRE HT2	on request	on request
MULTIFLAM TS 2300.1 PRE HT2	on request	on request
MULTIFLAM TS 3400.1 PRE HT2	on request	on request



HT2.2 versions, suitable to work with pre-heated combustion air up to 250 °C, are available on request according to feasibility

i Burner supplied with terminal block with burner controller in a separate box

Oil pump on board up to MULTIFLAM TS 600.1; separated oil pumping unit (not included in the scope of supply) starting from MULTIFLAM TS 800.1

Nozzle not included in the code of the burner
 See "Oil spill back nozzles" section at page 253

OVERALL DIMENSIONS: Burner body + combustion head¹

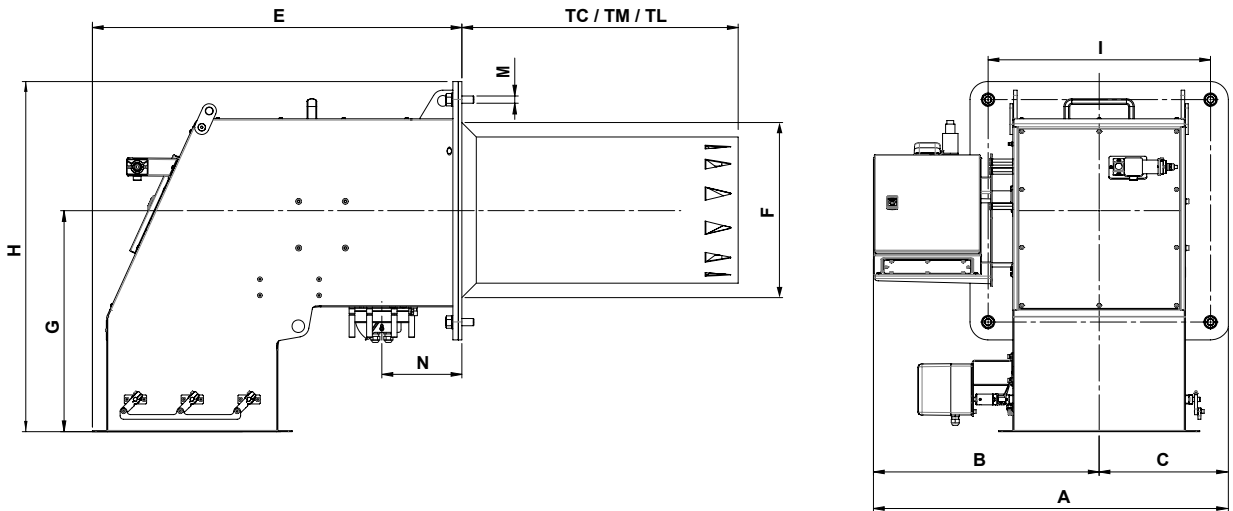

Connecting flange

Gas: TS 500.1 ... 12000.1
 Oil and dual: TS 100 ... 1200.1

Gas: TS 1800.1 ... 42000.1
 Oil and dual: TS 1800.1 ... 3400.1

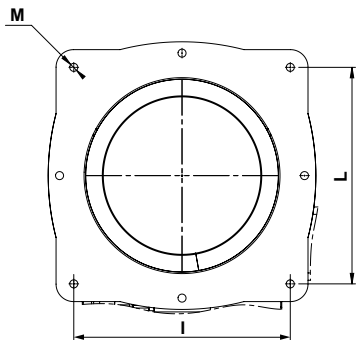
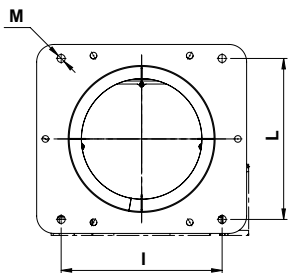

Model	A	B	C	TC	TM	TL	E	F	G	H	I	L	M	N
TS 500.1	523	307	216	205	284	394	556	160	290	415	185/200	185/200	4xM10	140 ²
TS 1000.1	523	307	216	205	284	394	556	190	290	415	185/200	185/200	4xM10	140 ²
TS 1500.1	620	376	373	345	445	545	556	205	290	415	185/200	185/200	4xM10	140 ²
TS 2000.1	584	420	164	345	445	545	637	224	379	545	270	270	4xM16	125
TS 3000.1	623	440	183	400	540	640	650	263	375	545	270	270	4xM16	125
TS 4000.1	746	530	216	400	550	640	798	310	392	587	315	315	4xM16	190
TS 6000.1	746	536	210	450	560	690	847	325	409	619	330	330	4xM16	195
TS 8000.1	907	602	305	490	630	770	802	377	480	760	485	485	4xM20	195
TS 10000.1	998	638	360	490	640	790	1040	420	556	889	620	620	4xM20	195
TS 12000.1	998	638	360	490	640	790	1030	440	622	982	620	620	4xM20	195
TS 14000.1	947	629	318	490	640	790	908	464	523	841	550	550	4xM20	195
TS 18000.1	1056	673	383	590	710	810	1480	497	676	982	620	620	4xM20	210
TS 20000.1	1099	706	393	640	760	810	1054	580	653	1055	695	695	4xM20	210
TS 23000.1	1307	835	472	640	760	850	1549	712	767	1248	800	800	4xM20	400
TS 34000.1	1307	835	472	700	850	950	1549	712	767	1248	800	800	4xM20	400
TS 42000.1	1508	918	590	700	850	950	1519	855	900	1490	1020	1020	4xM20	400

i ¹: Drawings and dimensions (in mm) make reference to a Low NOx class 3 burner in electronic version: they are shown for informational purposes only and may vary according to the chosen configuration
²: Gas train connection on the right side of the burner
 Head length: TC short / TM medium / TL long

OVERALL DIMENSIONS: Air Duct

Gas: TS 500.1 ... 3000.1
Oil and dual fuel: TS 100 ... 300.1

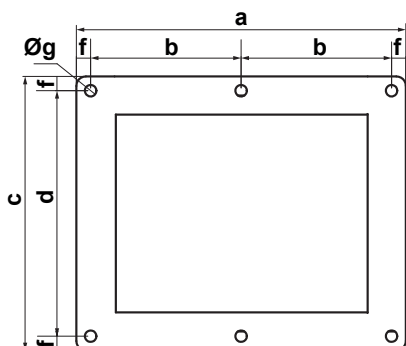

Gas: TS 4000.1 ... 8000.1 and 14000.1
Oil and dual fuel: TS 400 ... 800.1

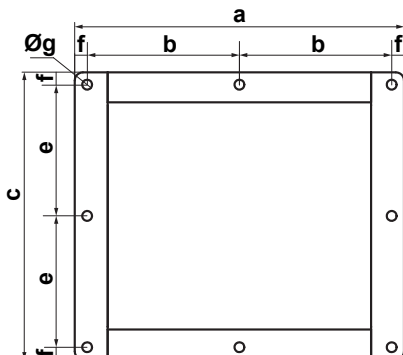

Gas: TS 10000.1 ... 12000.1
Oil and dual fuel: TS 1000.1 ... 1200.1

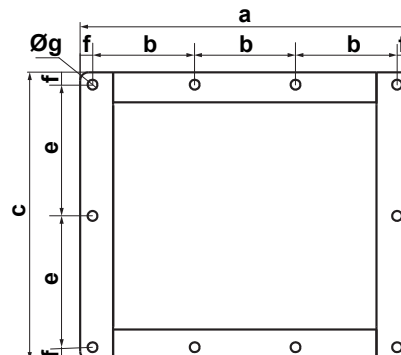

Gas: TS 18000.1 and 20000.1
Oil and dual fuel: TS 1800.1

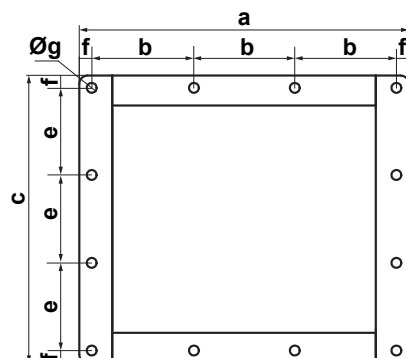

Gas: TS 23000.1 ... 34000.1
Oil and dual fuel: TS 2300.1 ... 3400.1

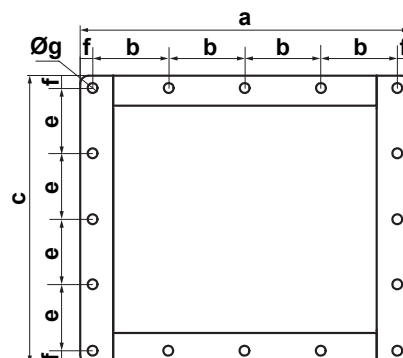

Gas: TS 42000.1

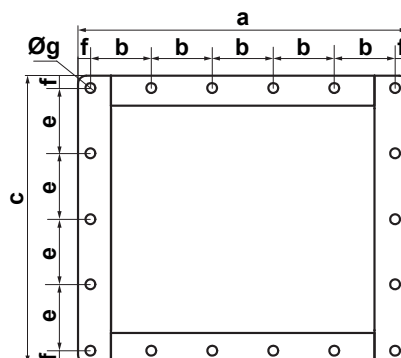

Model	a	b	c	d	e	f	Øg
TS 500.1	303	136,5	252	222	-	15	6x R12
TS 1000.1	303	136,5	252	222	-	15	6x R12
TS 1500.1	303	136,5	252	222	-	15	6x R12
TS 2000.1	345	157,5	287	257	-	15	6x R12
TS 3000.1	345	157,5	287	257	-	15	6x R12
TS 4000.1	400	185	349	-	159,5	15	8x R12
TS 6000.1	470	220	361	-	165,5	15	8x R12
TS 8000.1	506	234	402	-	182	19	10x R14
TS 10000.1	557	173	474	-	218	19	10x R14
TS 12000.1	557	173	561	-	261,5	19	10x R14
TS 14000.1	561	261,5	508	-	235	19	8x R14
TS 18000.1	730	230,7	650	-	204	19	12x R14
TS 20000.1	696	226	614	-	192	19	12x R14
TS 23000.1	930	223	828	-	197,5	19	16x R14
TS 34000.1	930	223	828	-	197,5	19	16x R14
TS 42000.1	1042	200,8	828	-	197,5	19	18x R14

 Dimensions in mm

Ecoflam is continuously focused on an environmental program, both for optimisation of existing products and new developments, with the target to offer efficient, reliable and technologically advanced solutions able to meet the most restrictive European legislation requirements, in particular in terms of emission and energy saving.



New series of low NOx oil burners for OEM «Unit» applications are available with one stage, two stage or modulating operation. Burners suitable to work with alternative fuels such as biofuels and biogas are also available.

Low NOx one stage burners



MAX LN range

- One stage light oil burners available in different rating sizes from 15 to 65 kW
- Low NOx combustion technology able to guarantee NOx emissions below 115 mg/kWh (EN 267:2009)
- High ventilation performance
- Easy installation, adjustment and maintenance

Low NOx special customized models



UB1 VD range

- Two stage light oil burners covering an output range from 11 to 42 kW
- Blue Flame combustion technology with NOx emissions below 110 mg/kWh (EN 267:2009)
- Suitable to operate in altitude with high performances

Low NOx modulating burners



F10/F15 range

- Innovative modulating light oil burners with an output range from 8 to 62 kW
- Blue Flame combustion technology granting NOx emissions below 100 mg/kWh (EN 267:2009)
- Patented modulating system
- High ventilation performance
- Low noise and low electrical consumption
- Easy setting through a 3-point curve

Burners suitable for low sulphur oil and light oil/biofuel blends (biofuel up to 10%). Special dedicated burner models available for kerosene Low NOx applications.

Ecoflam is renowned for its ability to conceive and build flexible products and to propose customized solutions for any type of applications. Successful and satisfied customers, both from OEM or distribution fields, demonstrate throughout the years that Ecoflam is able to meet their requests offering a wide range of special products capable to satisfy even the most difficult ones.

**High
Temperature
versions**



**Products for
industrial
applications**



**Two-gas
burners
(i.e. Gas /
Biogas)**



**2-head and
4-head
burners**

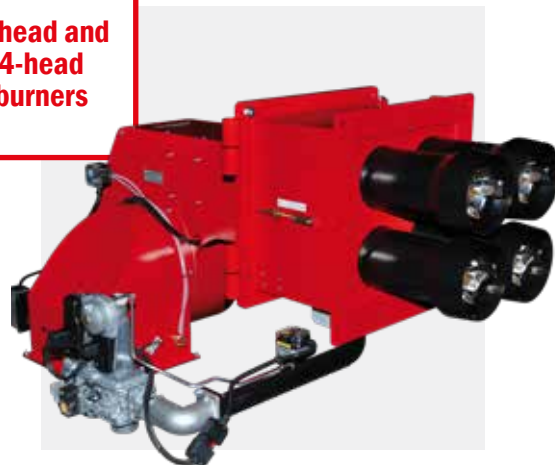

**FGR System
(Flue Gas
Recirculation)**

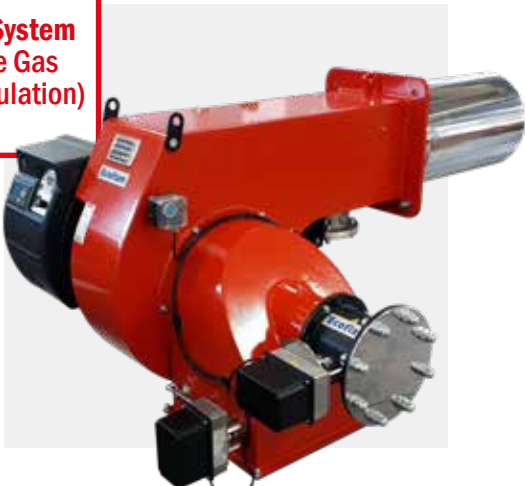

**Remote
control
panel**



The continuous research has led to the acquirement of a specific know-how on many industrial processes and the possibility to develop advanced technology burners and industrial combustion systems combining together the use of conventional burners and duct burners.

The MAX-PRO industrial range is dedicated to light process industry and it is suitable for several production processes and for any fuel: natural gas, LPG and lean gas in many mixtures. These combustion systems are developed and dimensioned to satisfy the needs of all the industrial thermal processes in which they are installed.

The possibility to choose within a wide range of products, the high flexibility of installation and the constant technical support and assistance allow our customers to find the correct solution to any requirement coming from the industrial combustion.

To do so, ECOFLAM offers combustion systems throughout a proper selection of dedicated devices with the aim to satisfy the required specifications and offer the most appropriate solution for a wide range of application fields:



TEXTILE



PAPER



DRYERS



INDUSTRIAL PAINTING/COATING
AUTOMOTIVE



HEAT SURFACE TREATMENT



METALLURGICAL



AUTOMATION AND SUPERVISING



ENVIRONMENT



FOOD

PRODUCT RANGE OVERVIEW

MB LMT



MB LMT HCA



**HTC
HTS
HTI**

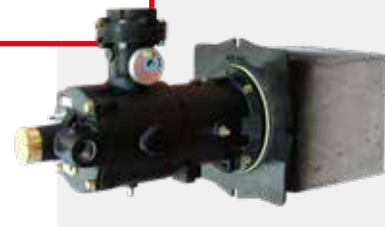

MVRT



**DBC LD MB
DBC LLD MB**



**DBO
DBC**

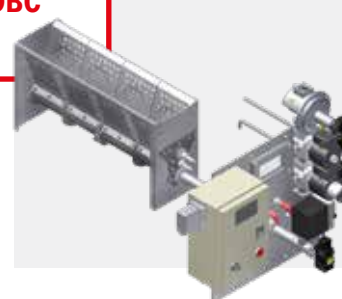

SSDBS



SSDBD



HGC



PRODUCT RANGE OVERVIEW**MB LMT****Monoblock high ratio regulation**

The "MB LMT" (Mono-Block Low Medium Temperatures) gas burner series is ideal for all the installations requiring a compact and silent combustion group with high turn-down ratio and a maximum temperature of process up to 400 °C

- Light and handy structure combined with reduced overall dimensions
- Suitable for direct or indirect heating
- Up to 5÷7 mbar backpressure (with adequate feedings)
- The gas train, the combustion air blower and the automatic burner control unit are located externally to the burner, with orientation that can be defined according to the installation requirements;
- Completely automatic operation allows different regulation controls such as modulating on gas or modulating on ratio
- Turn-down ratio of 30:1 with neutral combustion chamber

MB LMT HCA**High ratio regulation**

The "MB LMT HCA" (Mono-Block Low Medium Temperatures Hot Combustion Air) gas burner series is ideal for all the installations requiring a compact and silent combustion group with high turn-down ratio and a maximum temperature of process up to 600 °C

- Burner body entirely insulated and covered by a protective metallic layer to prevent heat dispersion that could injure the technical staff during the operating phases of the combustion apparatus
- Temperature of the combustion air in inlet up to 250 °C
- Gas train and automatic burner control unit are located externally to the burner, with orientation that can be defined according to the installation requirements
- High temperature combustion air fan available on request
- Completely automatic operation allowing different regulation controls such as modulating on gas or modulating on ratio (turn-down ratio up to 20:1)

**HTC
HTS
HTI****Intensive high/medium speed**

The High Temperature gas burners "HTC" (concrete casting cone), "HTS" (silicon carbide cone) and "HTC" (with steel flame tube) are burners with strong construction layout and used in all the installations in which is required a certain temperature resistance and dedicated flame velocities (Low, Medium, or High Velocity)

- Wide choice of models available
- Burners are equipped with ignition electrode and detection probe
- Possibility of choosing between different existing flame cones
- Combustion air temperature up to 100 °C as standard
- HTC and HTS are available also as a package (turn down ratio 10:1 ÷ 15:1)

MVRT**Metallic volumetric for radiant tube**

The "MVRT" series gas blown-air burners are compact, strong, and of nozzle-mix type, designed to operate in radiant tubes with maximum combustion efficiency over varying operating conditions.

- Optimum flame stability and mixing at all firing rates
- Burners are equipped with ignition electrode and detection probe
- Progressive combustion inside the tube for higher temperature uniformity and longer life of the tube itself
- Possibility to work in all types of radiant tubes ("U", "P", "W")
- Combustion air temperature up to 100 °C as standard

PRODUCT RANGE OVERVIEW

**DBC LD MB
DBC LLD MB**



Monoblock air duct burners

Duct burners "DBC LD/LLD MB" are ideal for generating volumes of clean, hot air.

- The turndown ratio goes from 10:1 to 15:1, depending on the model
- Applications include oven, dryers, fume incinerators, and similar industrial equipment
- All models feature an integral combustion air blower mounted on the burner steel case
- By supplying the correct air volume and pressure to the burner, the blower allows stable operation over a wide range of duct velocities without installing a profile plate around the burner
- Burner installation must be in suction (or slightly in pressure on demand)

**DBO
DBC**

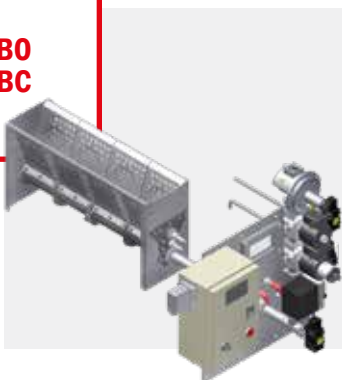

"Open Back"/"Close Back" monoblock air duct burners

"DBO" (Open Back) and "DBC" (Close Back) burners are extremely flexible and used in all those applications where it is required the direct heating of large amount of air with a small increase in temperature.

- Mixing heads with modular design to obtain a distribution of the power on a surface suitable to allow a correct mixing with the process air
- The combustion air is the same as the process air, taken through the mixing head by a suitable reduction of the duct section; the consequent increase in speed allows to have a correct and complete combustion
- Application of this range is only possible when free O₂>19% and when in the process air there aren't other gases in a concentration that can cause uncontrolled combustion reactions
- This type of heating has an efficiency of 100%: the whole combustion energy is transferred directly to the process (direct exchange combustion)

**SSDBS
SSDBD**



Self standing air duct burners (Single and Dual line)

The air duct burners series is used in every type of industrial process where it is required the direct heating of ducted air.

- Package is composed by a modular burner properly dimensioned and assembled in order to guarantee the best heat exchange between process air and combustion products
- An air box is created in the lower part of the burner body which will make up the burner structure. The air box, made with a modular structure like the burner itself, is made of reinforced stainless steel or carbon steel and houses the special process air fans, suitably sized for duct burner feeding
- Gas train is fixed to the burner structure under the air box and is housed along the entire length of the burner; the junction box containing the transformer igniter and the terminal board is fixed on a side of the burner structure
- Ignition is preferentially done with a pilot burner; the two main steps, ignition and operation, are managed by the flame control installed inside the control panel

HGC



Hot air generators

The "HGC" air draught generator series is used in all those applications where it is required a direct air heating during industrial processes.

- Assembly is made of a duct section with suitable materials resistant to temperature and/or treated fluid, and a "DBC" burner correctly dimensioned and assembled, in order to allow the best exchange between combusted gas and process air
- Comburent air can be supplied by an electro-blowing fan, which carries the comburent to the mixing head through a duct
- Combustion air can be obtained also by process, using an "Open Back" module (DBO): in this case part of the process fluid is conveyed to the mixing head by means of an increase in speed, due to a narrowing of the channel in which the burner is located. This application is possible only with oxygen level >19% during the process fuel

FGR

Ecoflam is renowned worldwide for providing high efficiency and reliable burners with significant energy savings and extreme ease of installation, maintenance and flexible boiler-burner matching. Following a philosophy of continuous improving, the R&D Laboratory is constantly working to produce better results, such as the reduced NOx level emissions.

Decades of presence on the international market have enabled Ecoflam to develop a considerable experience in customizing burners and developing innovative technologies which are attentive to the issue of polluting emissions, even in the most demanding applications.

Ecoflam is therefore well placed to provide solutions for the growing number of markets which are enacting ever more restrictive emissions regulations.

In the laboratory of Resana, Italy, the R&D technicians are able to simulate real-life working conditions and measure the performance of burners fitted with Low NOx combustion heads and the **FGR system**.

The excellent results obtained in this field have enabled Ecoflam to offer a complete range of monoblock and duoblock products equipped with the FGR technology.

The principle of external flue gas recirculation consists in sending a mixture of comburent air and flue gas to the combustion head, thus reducing the NOx emissions. This technology enables Ecoflam to guarantee **emissions of less than 30 mg/kWh**, a value which is hard to obtain with conventional combustion systems, and offer cutting-edge products which satisfy the requirements of any current regulations.



CODES

■ Two stage progressive/modulating electronic

Model	Burner head length			FGR valve ¹	
	TC	TM	TL	Size	Code
BLU 700.2 LN PRE FGR	3144882	3145004	3144881	DN80	3145039
BLU 1000.2 LN PRE FGR	3144884	3145005	3144883	DN80	3145039
BLU 1200.2 LN PRE FGR	3145006	3144886	3144885	DN80	3145039
BLU 1500.2 LN PRE FGR	3144888	3145277	3144887	DN80	3145039
BLU 2000.4 LN PRE FGR	-	3146754	3146755	DN100	3145040
BLU 3000.4 LN PRE FGR	-	3146800	3146799	DN100	3145040
BLU 4000.4 LN PRE FGR	-	3147110	3147111	DN125	3145041
BLU 5000.4 LN PRE FGR	-	3146813	3146814	DN150	3145042
BLU 6000.4 LN PRE FGR	-	3146815	3146816	DN150	3145042
BLU 7000.4 LN PRE FGR	-	3147216	3147217	DN200	3145043
BLU 8000.2 LN PRE FGR	3144902	3145292	3145293	DN200	3145043
BLU 10000.2 LN PRE FGR	3145294	3144904	3145687	DN200	3145043
BLU 12000.2 LN PRE FGR	3145296	3144906	3145297	DN200	3145043
BLU 15000.2 LN PRE FGR	3144908	3145298	3145299	DN250	3145044
BLU 18000.2 LN PRE FGR	3144910	3145300	3145301	DN250	3145044

i ¹: FGR valve included in the scope of supply

FUNCTIONAL SCHEMES

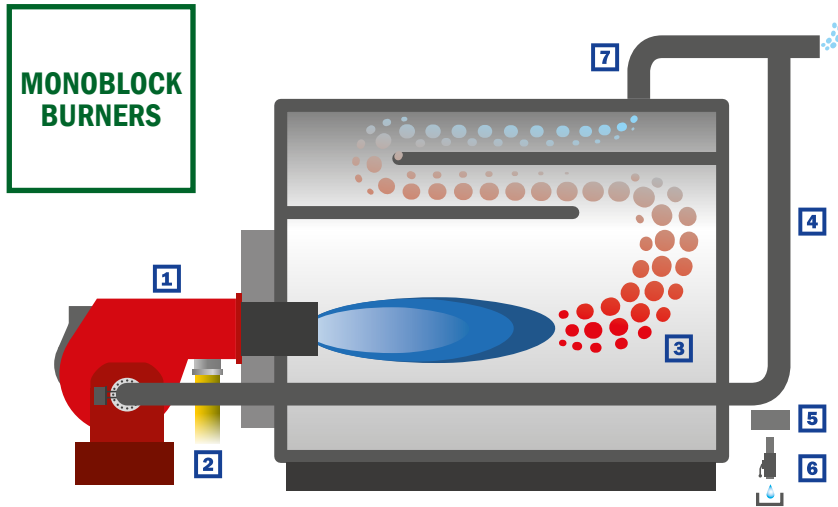

The FGR system on **monoblock burners** provides that the flue gas is drawn in by the burner fan. The installer must therefore install a line connecting the flue gas outlet to the burner fan inlet. The extraction point is generally at the base of the flue pipe, where the pressure is close to zero. A suction is generated in the burner intake box which is a function of the fan curve and the air damper position. In order to ensure an adequate rate of flue gas from the stack and thus to provide the required NOx reduction, the pipeline between the flue and the burner must be sized to minimise the pressure drop.

- Legenda:**
- | | | |
|---------------|--------------------|-----------|
| 1 - Burner | 4 - Flue pipeline | 7 - Stack |
| 2 - Gas inlet | 5 - Drainage | |
| 3 - Furnace | 6 - Drainage valve | |

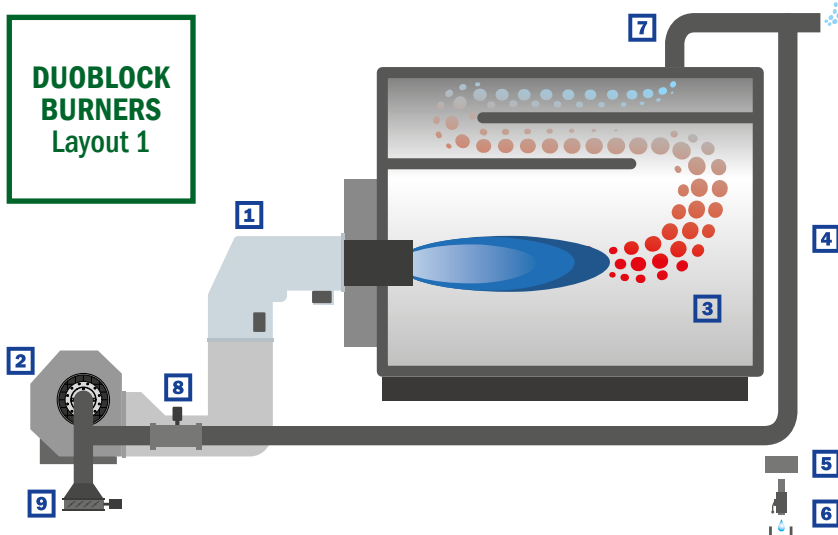

The FGR system for **duoblock burners**, in which the draughtfan is installed in a remote position, has a different layout, since the flue gas line must enter the circuit upstream of the fan itself. Furthermore, to generate the required suction to convey the flue gas into the fan and mix it with the comburent air, the flow regulation device must be located upstream of the flue gas inlet into the fan suction circuit. As for monoblock units, also here the flue gas line must be properly sized.

- Legenda:**
- | | | |
|-----------------|--------------------|----------------|
| 1 - Burner | 4 - Flue pipeline | 7 - Stack |
| 2 - Draught fan | 5 - Drainage | 8 - FGR valve |
| 3 - Furnace | 6 - Drainage valve | 9 - Air damper |

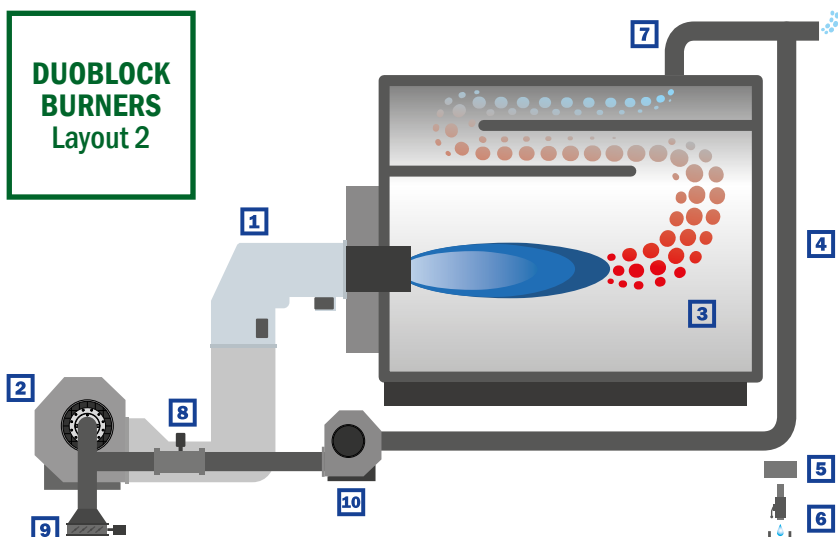

In case of installations with duoblock burners there is an alternative option to layout 1. In this scenario there is a further draught fan dedicated to the flue: it takes the flue from the stack and pushes it into the duct between the burner and the fresh air draught fan. The flue damper is just after the flue fan. The air damper is on burner board and therefore it adjusts the rate of the mixture between the flue and the fresh air. Also in this case the flue duct has to be properly sized in order to minimize the pressure drop.

- Legenda:**
- | | | |
|---------------------------|--------------------|--------------------|
| 1 - Burner | 4 - Flue pipeline | 8 - FGR valve |
| 2 - Fresh air draught fan | 5 - Drainage | 9 - Air damper |
| 3 - Furnace | 6 - Drainage valve | 10 - FGR draft fan |
| | 7 - Stack | |

GAS TRAIN COMPOSITION

ECOFLAM gas trains are delivered separately for all gas and dual fuel burners and are available in different configurations:

- **EN676 configuration** (gas train + kit/accessories to comply with EN676 Directive);
- **Export configuration** (additional options to be added by installer in compliance with local safety regulations and codes of practise)

■ MULTIBLOC DUNGS

Compact double solenoid valve with built-in filter, gas governor and gas pressure switch

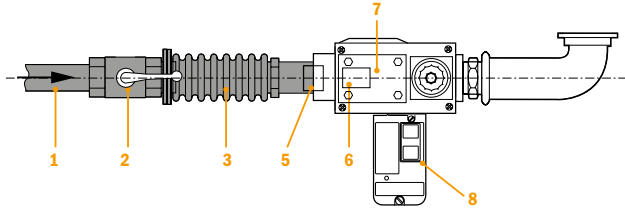

Configuration for electronic burners (PRE):

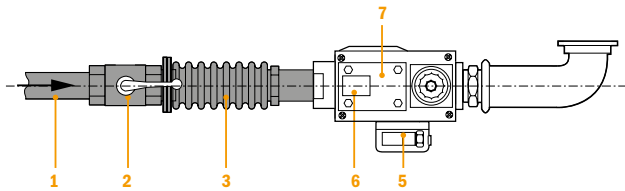

1. Main gas pipe		
2. Ball valve	ACS	
3. Antivibrating joint	ACS	
5. Gas pressure switch		EN676 CONFIGURATION
6. Safety + Working gas valve	GAS TRAIN	
7. Gas governor and filter		
8. Tightness control ⁽¹⁾	KIT ⁽¹⁾	
Maximum gas pressure switch	KIT	
Gas train connection pipe ⁽²⁾	GTCP ⁽²⁾	

- ! ¹: according to the European Standard for gas trains in EN676 Configuration a tightness control device must be included over 1200 kW (already included on PRE burners)
- ! ²: starting from models BLU 1700.1 / MULTICALOR 170.1 / MULTIFLAM 300.1, in order to fit the gas train, the corresponding connection pipe must be ordered

■ VGD SIEMENS

Double gas valve with actuators, gas regulator and gas pressure switch (gas filter not included)

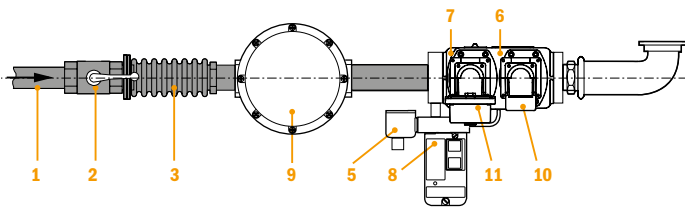

Configuration for electronic burners (PRE):

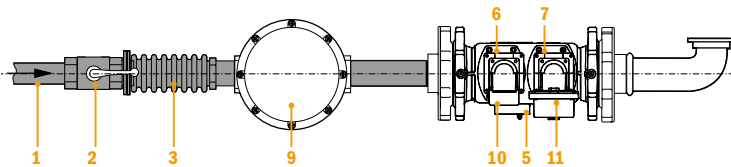

1. Main gas pipe		
2. Ball valve	ACS	
3. Antivibrating joint	ACS	
5. Gas pressure switch		EN676 CONFIGURATION
6. Safety gas valve + 10. Actuator	GAS TRAIN	
7. Working gas valve + 11. Actuator		EXPORT CONFIGURATION
8. Tightness control ⁽¹⁾	KIT ⁽¹⁾	
9. Gas filter	ACS	
Maximum gas pressure switch	KIT	
Gas train connection pipe ⁽²⁾	GTCP ⁽²⁾	

- ! ¹: according to the European Standard for gas trains in EN676 Configuration a tightness control device must be included over 1200 kW (already included on PRE burners)
- ! ²: starting from models BLU 1700.1 / MULTICALOR 170.1 / MULTIFLAM 300.1, in order to fit the gas train, the corresponding connection pipe must be ordered

! for VGD gas trains in EN676 Configuration a filter must be ordered as a separate device

! Default blank spring: head pressure 0...22 mbar; starting from BLU 3000.1/MULTICALOR 300.1/MULTIFLAM 300.1 choose and change spring and damping (to be fitted during installation on site)

! For minimum inlet pressures higher than 250 mbar, choose the pressure switch GW500 (to be fitted during installation on site)

■ Gas trains for MAX GAS 40...250 P in EN676 Configuration

Model	Size	Code
GT-D1-MBC65DLE-RP15-MAXGAS40-120	Rp1/2"	3141885
GT-D1-MBC120DLE-RP20-MAXGAS40-120	Rp 3/4"	3141886
GT-D1-MBDLE403-RP15-MAXGAS40-120	Rp1/2"	3123944
GT-D1-MBDLE405-RP20-MAXGAS40-120	Rp 3/4"	3123560
GT-D1-MBDLE407-RP20-MAXGAS170-250	Rp 3/4"	3123525
GT-D1-MBDLE410-RP25-MAXGAS170-250	Rp1"	3123947
GT-D1-MBDLE412-RP32-MAXGAS170-250	Rp1"1/4	3141899

■ Gas trains for MAX GAS 120...250 PAB in EN676 Configuration

Model	Size	Code
GT-D2-MBZRDLE405-RP20-MAXGAS40-120	Rp 3/4"	3123960
GT-D2-MBZRDLE407-RP20-MAXGAS170-250	Rp 3/4"	3123961
GT-D2-MBZRDLE410-RP25-MAXGAS170-250	Rp1"	3123962
GT-D2-MBZRDLE412-RP32-MAXGAS170-250	Rp1"1/4	3141901

■ Gas trains for MAX GAS 350...700 P/PAB/PR in EN676 Configuration

Model	Size	Code
GT-D2-MBDLE407-RP20-MAXGAS350-500	Rp 3/4"	3142392
GT-D2-MBDLE410-RP25-MAXGAS350-500	Rp1"	3142665
GT-D2-MBDLE412-RP32-MAXGAS350-500	Rp1"1/4	3142295
GT-D2-MBDLE415-RP40-MAXGAS350-500	Rp1"1/2	3142296

i "EN676 Configuration" includes all the mandatory components in order to comply with EN676 regulation
Additional accessories and kits shall be installed by the installer in accordance to the local safety regulations and codes of practise

■ Gas trains for MAX GAS 40-250 in EXPORT Configuration

Model	Size	Code
GT-B1-E6GSRP-RP15-MAXGAS40-120	Rp1/2"	3141888
GT-B1-EG12L-RP15-MAXGAS40-120	Rp1/2"	3141887
GT-K1-VAS125-RP25-MAXGAS170-250	Rp1"	3142815
GT-K1-VAS240-RP40-MAXGAS170-250	Rp1"1/2	3142816

i Additional accessories and kits shall be installed by the installer in accordance to the local safety regulations and codes of practise

■ GAS TRAINS FOR TWO STAGE AND PROGRESSIVE MECHANICAL BURNERS (PAB, PR)

■ Gas trains for BLU, MULTICALOR and MULTIFLAM in EN676 Configuration

Model	Size	Outlet pressure range	Code
GT-D2-MBDLE412-RP32-BLU/MULTI S20	Rp1"1/4		3141845
GT-D2-MBDLE415-RP40-BLU/MULTI S20	Rp1"1/2	4 ... 20 mbar	3141846
GT-D2-MBDLE420-RP50-BLU/MULTI S20	Rp2"		3141847
GT-D2-MBDLE407-RP20-BLU/MULTI S50	Rp 3/4"		3141843
GT-D2-MBDLE410-RP25-BLU/MULTI S50	Rp1"	4 ... 50 mbar	3142022
GT-D2-MBDLE412-RP32-BLU/MULTI S50	Rp1"1/4		3147621
GT-D2-MBDLE415-RP40-BLU/MULTI S50	Rp1"1/2	20 ... 50 mbar	3147622
GT-D2-MBDLE420-RP50-BLU/MULTI S50	Rp2"		3147698

i "EN676 Configuration" includes all the mandatory components in order to comply with EN676 regulation

■ Gas trains for BLU, MULTICALOR and MULTIFLAM in EXPORT Configuration

Model	Size	Suitable for	Code
GT-S1-VGD20-RP50-PS1	Rp2"	BLU 1200.1...2000.1 MULTICALOR 140-200.1 MULTIFLAM 200.1...600.1	3123860
GT-S1-VGD40-DN65-PS1	DN65	BLU 1200.1...2000.1 MULTICALOR 200.1 MULTIFLAM 200.1...1000.1	3124110
GT-S1-VGD40-DN80-PS1	DN80	BLU 1700.1/2000.1 MULTICALOR 170.1/200.1 MULTIFLAM 200.1...600.1	3142026
GT-S1-VGD40-DN100-PS1	DN100	MULTIFLAM 300.1...1800.1	3141869
GT-S1-VGD40-DN125-PS1	DN125	MULTIFLAM 500.1...1800.1	3142666
GT-S1-VGD20-RP50-PS1-S	Rp2"		3147130
GT-S1-VGD40-DN65-PS1-S	DN65	BLU 1700.2 BLU 2500.2	3147131
GT-S1-VGD40-DN80-PS1-S	DN80		3147132
GT-S1-VGD20-RP50-PS3	Rp2"		3146004
GT-S1-VGD40-DN65-PS3	DN65		3146005
GT-S1-VGD40-DN80-PS3	DN80	BLU 3000.1...18000.1 MULTICALOR 300.1...1800.1	3146006
GT-S1-VGD40-DN100-PS3	DN100		3146007
GT-S1-VGD40-DN125-PS3	DN125		3146008
Gas pressure switch GW500 A5 150 ... 500 mbar for VGD4x (flanged valves)			3143350
Gas pressure switch GW500 A6 150 ... 500 mbar for VGD20 (threaded valves)			3145164
Yellow spring (setting range pressure: 15...120 mbar) - Included in the delivery as an alternative to the installed blank spring			3142204
Red spring (setting range pressure: 100...250 mbar)			3141949
Damping throttle			3142207

! For VGD gas trains in EN676 Configuration a filter must be ordered as a separate device

! Default blank spring: head pressure 0...22 mbar; starting from BLU 3000.1/MULTICALOR 300.1/MULTIFLAM 300.1 choose the yellow spring (included in the delivery) and the damping throttle (to be fitted during installation on site)

! For minimum inlet pressures higher than 250 mbar, choose the pressure switch GW500 (to be fitted during installation on site)

■ GAS TRAINS FOR PROGRESSIVE ELECTRONIC BURNERS (PRE)

■ Gas trains for BLU PRE, MULTICALOR PRE and MULTIFLAM PRE in EN676 Configuration

Model	Size	Outlet pressure range	Code
GT-D2-MBDLE410-RP25-BLU/MULTI PS2 S22	Rp1"	4 ... 20 mbar	3145931
GT-D1-MBDLE412-RP32-BLU/MULTI PS2 S22	Rp1"1/4		3145932
GT-D1-MBDLE415-RP40-BLU/MULTI PS2 S22	Rp1"1/2		3145933
GT-D1-MBDLE420-RP50-BLU/MULTI PS2 S22	Rp2"		3145934
GT-D2-MBDLE415-RP40-BLU/MULTI PS2 S52	Rp1"1/2	20 ... 50 mbar	3147841
GT-D2-MBDLE420-RP50-BLU/MULTI PS2 S52	Rp2"		3147716

i "EN676 Configuration" includes all the mandatory components in order to comply with EN676 regulation

■ Gas trains for BLU PRE, MULTICALOR PRE and MULTIFLAM PRE in EXPORT Configuration

Model	Size	Suitable for	Code
GT-S1-VGD20-RP50-PS2	Rp2"	BLU 1200.1...6000.1 MULTICALOR 170...600.1 MULTIFLAM 200.1...600.1	3145790
GT-S1-VGD40-DN65-PS2	DN65	BLU 2000.1...10000.1 MULTICALOR 200.1...1000.1 MULTIFLAM 200.1...600.1	3145793
GT-S1-VGD40-DN80-PS2	DN80	BLU 1700.1...15000.1 MULTICALOR 170.1...1500.1 MULTIFLAM 200.1...600.1	3145814
GT-S1-VGD40-DN100-PS2	DN100	BLU 3000.1...18000.1 MULTICALOR 300.1...1800.1 MULTIFLAM 300.1...600.1	3145817
GT-S1-VGD40-DN125-PS2	DN125	BLU 5000.1...18000.1 MULTICALOR 500.1...1800.1 MULTIFLAM 500.1...600.1	3145823
GT-S1-VGD20-RP50-PS2-S	Rp2"		3147672
GT-S1-VGD40-DN65-PS2-S	DN65	BLU 1700.2 BLU 2500.2	3147673
GT-S1-VGD40-DN80-PS2-S	DN80		3147674
Gas pressure switch GW500 A5 150 ... 500 mbar for VGD4x (flanged valves)			3143350
Gas pressure switch GW500 A6 150 ... 500 mbar for VGD20 (threaded valves)			3145164
Yellow spring (setting range pressure: 15...120 mbar) - Included in the delivery as an alternative to the installed blank spring			3142204
Red spring (setting range pressure: 100...250 mbar)			3141949
Damping throttle			3142207

- !** For VGD gas trains in EN676 Configuration a filter must be ordered as a separate device
- !** Default blank spring: head pressure 0...22 mbar; starting from BLU 3000.1/MULTICALOR 300.1/MULTIFLAM 300.1 choose the yellow spring (included in the delivery) and the damping throttle (to be fitted during installation on site)
- !** For minimum inlet pressures higher than 250 mbar, choose the pressure switch GW500 (to be fitted during installation on site)

■ MB... GAS TRAINS (P, PAB AND PR BURNERS)

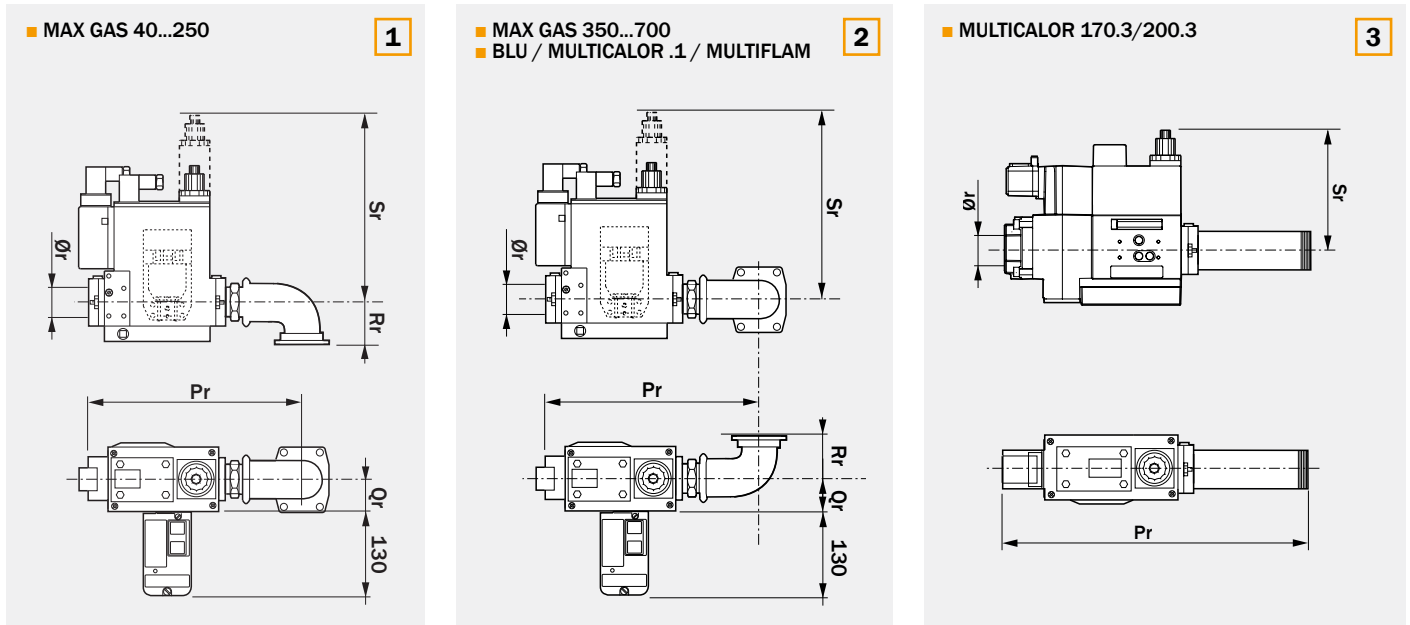

Code	Model	Ø	Pic.	Dimensions (mm)				
				Pr	Qr	Rr	Sr	Ør
3123525	GT-D1-MBDLE407-RP20-MAXGAS170-250	Rp 3/4"	1	194	55	55	140	3/4"
3123560	GT-D1-MBDLE405-RP20-MAXGAS40-120	Rp 3/4"	1	194	55	35	140	3/4"
3123944	GT-D1-MBDLE403-RP15-MAXGAS40-120	Rp1/2"	1	150	29	35	144	1/2"
3123947	GT-D1-MBDLE410-RP25-MAXGAS170-250	Rp1"	1	218	62	55	160	1"
3123960	GT-D2-MBZRDLE405-RP20-MAXGAS40-120	Rp 3/4"	1	194	50	35	210	3/4"
3123961	GT-D2-MBZRDLE407-RP20-MAXGAS170-250	Rp 3/4"	1	194	62	55	210	3/4"
3123962	GT-D2-MBZRDLE410-RP25-MAXGAS170-250	Rp1"	1	223	62	55	260	1"
3141843	GT-D1-MBDLE407-RP20-BLU/MULTI	Rp 3/4"	2	315	55	85	140	3/4"
3141845	GT-D1-MBDLE412-RP32-BLU/MULTI	Rp1"1/4	2	330	62	85	160	1"1/4
3141846	GT-D1-MBDLE415-RP40-BLU/MULTI	Rp1"1/2	2	410	50	85	175	1"1/2
3141847	GT-D1-MBDLE420-RP50-BLU/MULTI	Rp2"	2	420	50	85	175	2"
3141885	GT-D1-MBC65DLE-RP15-MAXGAS40-120	Rp1/2"	1	250	42	35	140	1/2"
3141886	GT-D1-MBC120DLE-RP15-MAXGAS40-120	Rp1/2"	1	260	42	35	140	1/2"
3141899	GT-D1-MBDLE412-RP32-MAXGAS170-250	Rp1"1/4	1	218	62	55	160	1"1/4
3141901	GT-D2-MBZRDLE412-RP32-MAXGAS170-250	Rp1"1/4	1	223	62	55	260	1"1/4
3142022	GT-D1-MBDLE410-RP25-BLU/MULTI	Rp1"	2	330	62	85	160	1"
3142295	GT-D1-MBDLE412-RP32-MAXGAS350-500	Rp1"1/4	2	335	62	150	160	1"1/4
3142296	GT-D1-MBDLE415-RP40-MAXGAS350-500	Rp1"1/2	2	400	50	150	175	1"1/2
3142392	GT-D1-MBDLE407-RP20-MAXGAS350-500	Rp 3/4"	2	335	55	150	140	3/4"
3142665	GT-D1-MBDLE410-RP25-MAXGAS350-500	Rp1"	2	335	62	150	160	1"
4399020	GT-D1-MBDLE415-RP40-PS3	Rp1"1/2	3	570	-	-	85	1"1/2
4399021	GT-D1-MBDLE420-RP50-PS3	Rp2"	3	570	-	-	109	2"
3147988	GT-D1-MBDLE407-RP20-PS1-40/120	Rp 3/4"	1	208	43	35	140	3/4"
3147989	GT-D1-MBDLE410-RP25-PS1-40/120	Rp1"	1	235	58	35	160	1"

■ MB-... GAS TRAINS (PRE BURNERS)

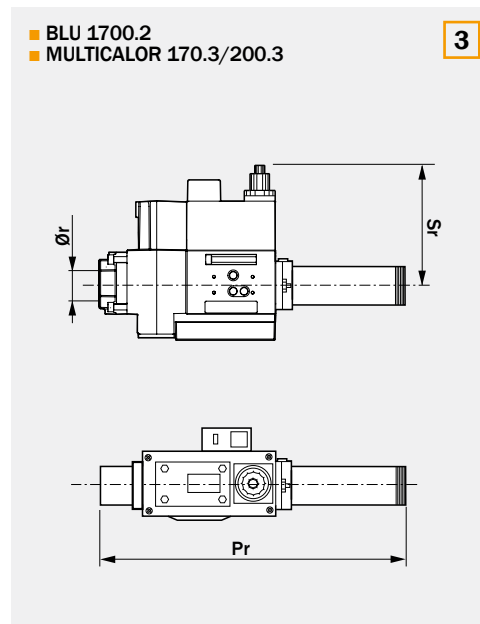
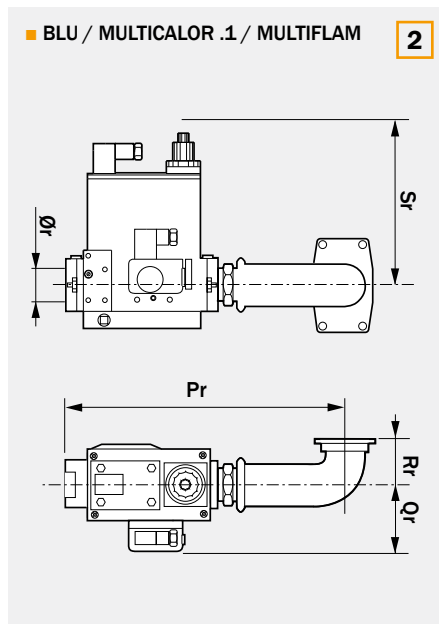
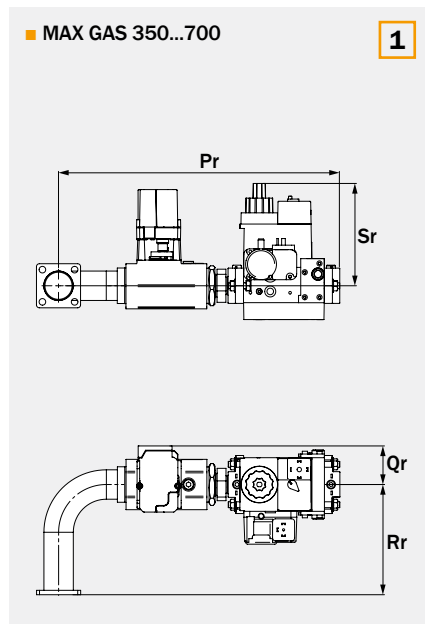

Code	Model	Ø	Pic.	Dimensions (mm)				
				Pr	Qr	Rr	Sr	Ør
3144928	GT-D1-MBDLE415-RP40-PS2	Rp1"1/2	3	592	50	-	169	1"1/2
3144929	GT-D1-MBDLE420-RP50-PS2	Rp2"	3	410	90	-	217	2"
3145931	GT-D1-MBDLE410-RP25-PS2	Rp1"	2	330	102	85	160	1"
3145932	GT-D1-MBDLE412-RP32-PS2	Rp1"1/4	2	330	102	85	160	1"1/4
3145933	GT-D1-MBDLE415-RP40-PS2	Rp1"1/2	2	410	90	85	175	1"1/2
3145934	GT-D1-MBDLE420-RP50-PS2	Rp2"	2	420	90	85	175	2"
3144772	GT-D1-MBDLE415-RP40-PS2	Rp1"1/2	3	589	-	-	169	1"1/2
3144773	GT-D1-MBDLE420-RP50-PS2	Rp2"	3	589	-	-	217	2"
3149309	GT-D1-MBDLE407-RP20-PS2-D200	Rp3/4"	1	385	58	150	140	3/4"
3149310	GT-D1-MBDLE410-RP25-PS2-D200	Rp1"	1	425	58	150	125	1"
3149311	GT-D1-MBDLE412-RP32-PS2-D200	Rp1"1/4	1	425	58	150	125	1"1/4
3149312	GT-D1-MBDLE415-RP40-PS2-D200	Rp1"1/2	1	495	58	150	170	1"1/2
3149313	GT-D1-MBDLE420-RP50-PS2-D200	Rp2"	1	525	58	150	220	2"

■ VGD... GAS TRAINS (PAB AND PR BURNERS)

■ VGD 20...

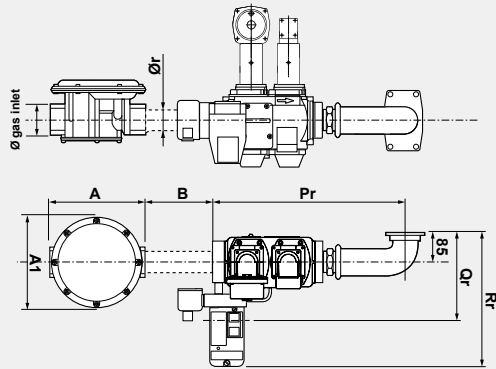

■ VGD 40...

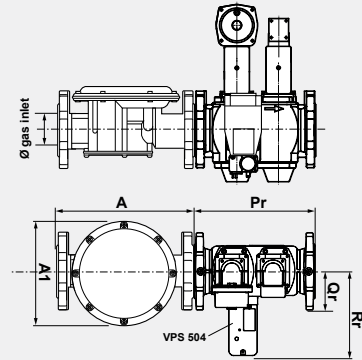

Code	Model	Ø	Dimensions (mm)			
			Pr	Qr	Rr	Ør
3123860	GT-S1-VGD20-RP50-BLU/MULTI	Rp2"	450	185	315	2"
3124110	GT-S1-VGD40-DN65-BLU/MULTI	DN65	290	97	211	DN65
3142026	GT-S1-VGD40-DN80-BLU/MULTI	DN80	310	102	218	DN80
3141869	GT-S1-VGD40-DN100-BLU/MULTI	DN100	350	113,5	229	DN100
3142666	GT-S1-VGD40-DN125-BLU/MULTI	DN125	400	127,5	243	DN125

■ VGD 20... PS1-S

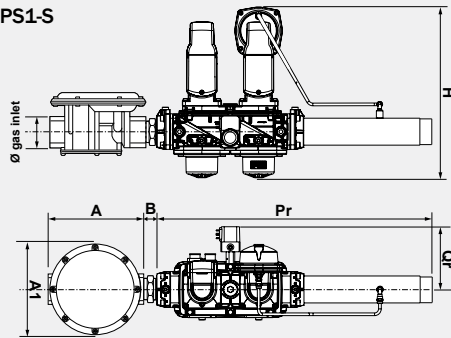

■ VGD 40... PS1-S

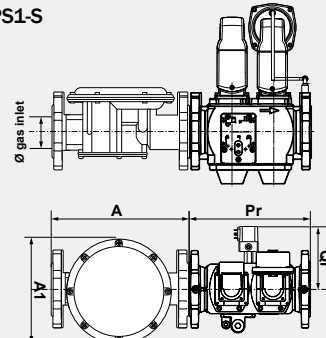

Code	Model	Ø	Dimensions (mm)			
			Pr	Qr	H	B
3147130	GT-S1-VGD20-RP50-PS1-S	Rp2"	689	34,9	382	36
3147131	GT-S1-VGD40-DN65-PS1-S	DN65	290	125,8	421	-
3147132	GT-S1-VGD40-DN80-PS1-S	DN80	310	127,3	445	-

■ VGD 20... PS3

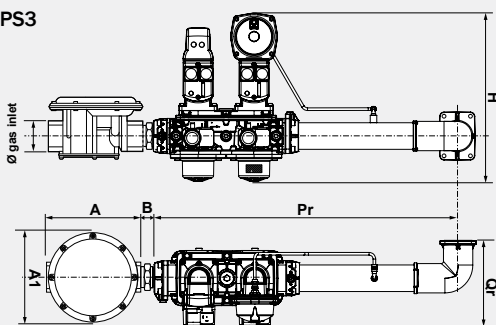

■ VGD 40... PS3

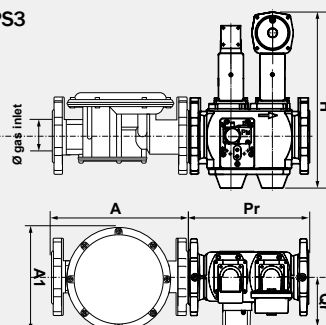

Code	Model	Ø	Dimensions (mm)			
			Pr	Qr	H	B
3146004	GT-S1-VGD20-RP50-PS3	Rp2"	689	193	382	36
3146005	GT-S1-VGD40-DN65-PS3	DN65	290	127,3	421	-
3146006	GT-S1-VGD40-DN80-PS3	DN80	310	127,3	445	-
3146007	GT-S1-VGD40-DN100-PS3	DN100	350	145,4	476	-
3146008	GT-S1-VGD40-DN125-PS3	DN125	400	158,4	524	-

■ VGD... GAS TRAINS (PRE BURNERS)

■ VGD 20... PS2

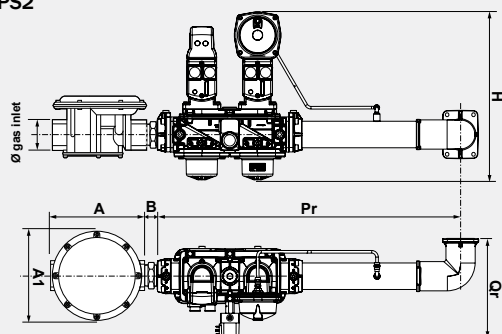

■ VGD 40... PS2

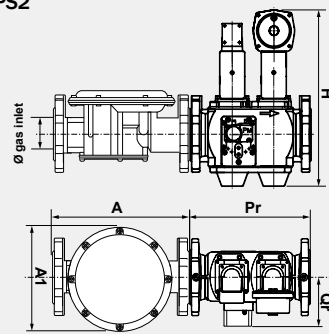

Code	Model	Ø	Dimensions (mm)			
			Pr	Qr	H	B
3145790	GT-S1-VGD20-RP50-PS2	Rp2"	689	226	382	36
3145793	GT-S1-VGD40-DN65-PS2	DN65	290	127,3	421	-
3145814	GT-S1-VGD40-DN80-PS2	DN80	310	127,3	445	-
3145817	GT-S1-VGD40-DN100-PS2	DN100	350	145,4	476	-
3145823	GT-S1-VGD40-DN125-PS2	DN125	400	158,4	524	-

■ VGD 20... PS2-S

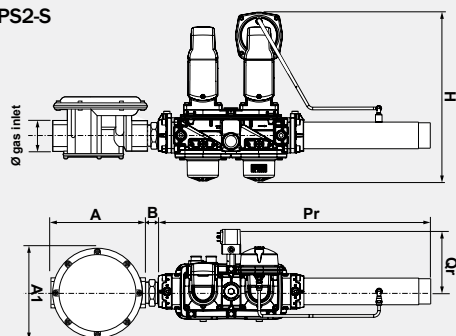

■ VGD 40... PS2-S

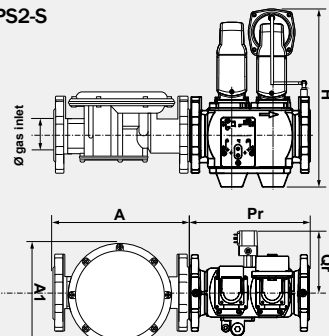

Code	Model	Ø	Dimensions (mm)			
			Pr	Qr	H	B
3147672	GT-S1-VGD20-RP50-PS2-S	Rp2"	628	34,9	382	36
3147673	GT-S1-VGD40-DN65-PS2-S	DN65	290	125,8	421	-
3147674	GT-S1-VGD40-DN80-PS2-S	DN80	310	127,3	445	-

■ GAS FILTER

Code	Model	Ø	Dimensions (mm)		
			A	A1	B
3121384	Gas filter Rp2"	Rp2"	186	186	>100
3124111	Gas filter DN65	DN65	290	212	-
3142088	Gas filter DN80	DN80	320	240	-
3142205	Gas filter DN100	DN100	380	280	-
3142206	Gas filter DN125	DN125	380	280	-
3142808	Gas filter DN150	DN150	450	310	-

GAS GOVERNOR WITH BUILT-IN FILTER

Size	Maximum gas pressure	Code
Rp1/2"	500 mbar	3142519
Rp3/4"	500 mbar	3142520
Rp1"	500 mbar	3142521
Rp1"1/4	500 mbar	3142522
Rp1"1/2	500 mbar	3142523
Rp2"	500 mbar	3142524
Rp2"	1 bar	3142051
DN65	1 bar	3141983
DN80	1 bar	3142538
DN100	1 bar	on request
DN125	1 bar	on request

! Default spring is neutral for outlet pressure range 10 ... 30 mbar

SPRINGS FOR GAS GOVERNOR

Model	Gas pressure range	Code
Green spring	5 ... 15 mbar	3142547
Neutral spring	10 ... 30 mbar	3142548
Violet spring	25 ... 80 mbar	3142549
Brown spring	70 ... 160 mbar	3142550
Blue spring	150 ... 280 mbar	3142551
White spring	270 ... 350 mbar	3142552
Green spring	5 ... 15 mbar	3142553
Neutral spring	10 ... 30 mbar	3142554
Violet spring	20 ... 70 mbar	3142555
Brown spring	65 ... 130 mbar	3142556
White spring	120 ... 250 mbar	3142557
Black spring	240 ... 350 mbar	3142558
Green spring	5 ... 15 mbar	3142559
Neutral spring	10 ... 30 mbar	3142560
Violet spring	30 ... 80 mbar	3142561
Brown spring	70 ... 220 mbar	3142562
Blue spring	210 ... 350 mbar	3142563
Red spring	25-80 mbar	3144252
Violet spring	60-120 mbar	3144253
Blue spring	100-220 mbar	3144254
White spring	200-450 mbar	3144255
Red spring	30-70 mbar	3144256
Violet spring	60-110 mbar	3144257
Brown spring	100-210 mbar	3144258
White spring	200-450 mbar	3144060

MANOMETER + PUSH BUTTON

Description	Pressure range	Code
Gas manometer 1/2"	0...60 mbar	3142056
Gas manometer 1/4"	0...250 mbar	3142055
Gas manometer 1/4"	0...1000 mbar	3142054
Push button 1/2"		3142057
Push button 1/4"		3142058

GAS FILTER

Size	Code
Rp1/2"	3141957
Rp3/4"	3142045
Rp1"	3142046
Rp1"1/2	3141954
Rp2"	3121384
DN65	3124111
DN80	3142088
DN100	3142205
DN125	3142206
DN150	3142808

ANTIVIBRATION JOINT

Size	Code
Rp1/2"	3122321
Rp3/4"	3122322
Rp1"	3122323
Rp1"1/4	3122324
Rp1"1/2	3122325
Rp2"	3122326
DN65	3142060
DN80	3122328
DN100	3122329
DN125	3142061
DN150	3147792

MANUAL VALVE

Size	Code
Rp1/2"	3158027
Rp3/4"	3142254
Rp1"	3121430
Rp1"1/4	3142253
Rp1"1/2	3142101
Rp2"	3142102
DN65	3142062
DN80	3143730
DN100	3141997
DN125	3141998

MAXIMUM GAS PRESSURE SWITCH

Model	Suitable for	Setting range	Code
KITPRES50	PR models <6 MW	5 ... 50 mbar	3141921
KITPRES150	PR models 6 ... 15 MW	30 ... 150 mbar	3142033
KITPRES500	PR models >15 MW	50 ... 500 mbar	3145166
KITPRES150	PRE models <15 MW	5 ... 150 mbar	3147771
KITPRES500	PRE models >15 MW	50 ... 500 mbar	3147772

TIGHTNESS CONTROL

Description	Suitable for	Code
Kit VPS504	MB-DLE/MB-ZRDLE and VGD65/80/100 valves, working with natural gas	3122303 ¹
	MB-DLE/MB-ZRDLE and VGD65/80/100 valves, working with LPG	3142190 ¹
	VGD20.503 valve, working with natural gas	3122305
	VGD20.503 valve, working with LPG	3142688
Kit VDK	VGD valves, DN125/DN150 sizes	3141922
Kit LDU		3142314
Adapter for MAX GAS 70 ... 250 PAB		3142239
Adapter for VPS pilot gas train		3142754

! ¹: for MAX GAS 70 ... 250 PAB this kit can only be mounted with the addition of an adapter (code 3142239)
 For gas trains in EN676 Configuration a tightness control device must be included over 1200 kW (already included on PRE burners)

KIT LPG

Description	Suitable for	Code
 LPG conversion kit for gas burners	MAX GAS 40 / 70 / 105 / 120	3122301
	MAX GAS 170 / 250	3122302
	MAX GAS 350 / 400 / 500	3142431
	MAX GAS 700	3146026
	BLU 700.1 / 1000.1 / 1200.1	3144610
	BLU 1500.3 LN	3149576
	BLU 2000.3 LN	3149577
	BLU 2500.3 / 3000.3 LN	3149288
	BLU 4000.3 LN	3149289
	BLU 5000.3 / 6000.3 LN	3149290

PRESSURE REDUCING UNITS

Outlet pressure <200 mbar

Model	Rough flow rate (inlet) [Nm ³ /h]				Min-Max inlet pressure	Inlet size	Outlet size	Type	Standard outlet pressure	Code
	at 1 barg	at 2 barg	at 3 barg	at 6 barg						
GT GR25-25	<100	<100	<100	<100	1 ... 6 barg	Rp1"	Rp1"	Threaded	90-170 barg	3145754
GT GR40-40	<300	<300	<300	<300	1 ... 6 barg	Rp1"1/2	Rp1"1/2	Threaded	85-180 barg	3145755
GT GR50-50	<390	<470	<470	<470	1 ... 6 barg	Rp2"	Rp2"	Threaded	85-180 barg	3145756
GT GR80-100	<1000	<1800	<1800	<1800	1 ... 6 barg	DN80	DN100	Flanged	50-130 barg	3145019
GT GR100-150	<1200	<2500	<4200	<4200	1 ... 6 barg	DN100	DN150	Flanged	45-120 barg	3145757

Outlet pressure between 200 and 500 mbar

Model	Rough flow rate (inlet) [Nm ³ /h]				Min-Max inlet pressure	Inlet size	Outlet size	Type	Standard outlet pressure	Code
	at 1 barg	at 2 barg	at 3 barg	at 6 barg						
GT GR25-25 H	<100	<100	<100	<100	1 ... 6 barg	Rp1"	Rp1"	Threaded	0,3-0,65 barg	3145759
GT GR40-40 H	<300	<300	<300	<300	1 ... 6 barg	Rp1"1/2	Rp1"1/2	Threaded	0,3-0,5 barg	3145760
GT GR50-50 H	<390	<470	<470	<470	1 ... 6 barg	Rp2"	Rp2"	Threaded	0,3-0,5 barg	3145761
GT GR80-100 H	<1000	<1800	<1800	<1800	1 ... 6 barg	DN80	DN100	Flanged	0,3-0,5 barg	3145762
GT GR100-150 H	<1200	<2500	<4200	<4200	1 ... 6 barg	DN100	DN150	Flanged	0,3-0,5 barg	3145763

! All units are supplied with no frame/support included

OIL SPILL BACK NOZZLES

Size (kg/h)	Model	Code
40		3145231
50		3145232
60		3142763
70		3145233
80		3145234
90		3145235
100		3142704
115		3142564
130		3142515
145		3142516
160		3142421
180		3142492
200	Fluidics W2 50° Threaded connection, 7/8"	3142690
225		3142489
250		3142768
275		3142805
300		3142490
330		3142703
360		3142513
400		3142497
450		3142483
500		3142699
550		3142416
600		3142506
650		3142870
700		3145236
300	Bergonzo B5 AA 45° Threaded connection, 7/8"	3142694
400		3142775
425		3142804
450		3142834
500		3142415
600		3141837
650		3144394
700		3142948
750		3142491
800		3142833
850	Bergonzo C5 45° Threaded connection, M35x1/2"	3145237
900		3142510
950		3145238
1000		3142947
1100 - A (models 700.1 ... 1200.1)		3142949
1000 - B (models 1500.1/1800.1)		3142961
1100		3142769
1200		3144774
1300		3144490
1400		3142776
1500		3145239

! Nozzles for MAIOR 45 ... 140 and MULTICALOR 70 ... 140 must be selected exclusively from the following table:

Size (kg/h)	Model	Code
26		3142326
33		3143301
37		3142511
39		3142503
49	Models for MAIOR 45 ... 140 and MULTICALOR 70 ... 140	3142351
50		3142512
62	Monarch Threaded connection, 9/16"	3143299
71		3142504
76		3142488
90		3145764
97		3141817

! Bergonzo nozzles are recommended for heavy oil burners

OIL FILTER

Description	Suitable for	Code
Oil filter 3/8"	MAX 1 ... 30	3142085
Oil filter 3/8"	MAX 35/45, MAIOR 45/60, MULTICALOR 70 ... 140	3142089

KIT SNORKEL

Description	Suitable for	Code
Air box with snorkel	MAX 1	65320006
	MAX 4	3146437
	MAX 8/12	3144691
	MAX 15	3147112
	MAX ... AB HS	3145906

KIT FOR AUTOMATIC FUEL SWITCH GAS/OIL FOR DUAL FUEL BURNERS

Description	Suitable for	Code
Kit automatic fuel switch	MULTICALOR and MULTIFLAM range	3142021

i The standard version works with manual fuel selection mode; with this kit, the change of fuel is activated by a gas pressure switch or by a timer

KIT BIODIESEL

Description	Suitable for	Code
Kit pump AS47	MAX 1 ... 30 and MAX P 25 AB HS	3141917
Kit pump AT2/AT3	MAX P 12/15 AB HS	3124103

MAGNETIC + SELF-CLEANING FILTER

Description	Suitable for	Code
Kit 50 kg	MAXFLAM range	3142092
Kit 250 kg	OILFLAM range	3141965

SEPARATE PRE-HEATER UNIT

Description	Code
From OILFLAM 300.1 pre-heater can be supplied separately with extra cost	on request

OIL PUMPING UNIT AND DAILY TANK

Description	Code
Separate daily tanks and pumping units	on request

HEAVY OIL HEATING AND PUMPING UNIT

Description	Code
"OIL RING" can be design and delivered assembled on skid or offered as single component	on request

SERVICE TANK

Description	Model	Characteristics	
		Diameter	Oil flow
Electric heating system	500	500 lt	500 kg/h
	1500	1500 lt	1500 kg/h
	2000	2000 lt	2000 kg/h
	3000	3000 lt	3000 kg/h
	4000	4000 lt	4000 kg/h

PRESSURE REGULATION SYSTEM

Description	Model	Characteristics	
		Diameter	Oil flow
 Light oil	400	3/8"	400 kg/h
	600	3/4"	600 kg/h
	1100	1"	1100 kg/h
	1500	1"	1500 kg/h
	2000	1"1/2	2000 kg/h
	3000	1"1/2	3000 kg/h
 Heavy oil	600	DN 50	600 kg/h
	900	DN 50	900 kg/h
	1200	DN 50	1200 kg/h
	2000	DN 50	2000 kg/h
	2500	DN 50	2500 kg/h
	4000	DN 50	4000 kg/h

OIL PUMP SKID (SINGLE PUMP OR TWO PUMPS)

Description	Model	Burner capacity
 Light oil - 1 or 2 pumps, complete with switch cabinet	800	8 MW
	1000	10/12 MW
	1800	15/18 MW
	2300	25 MW
 Heavy oil - 1 or 2 pumps, with electrical pre-heating system, complete with switch cabinet	800	8 MW
	1000	10/12 MW
	1800	15/18 MW
	2300	25 MW

DEGASSING UNIT

Description	Suitable for
Degassing unit complete with all required accessories	Light oil
	Heavy oil

SILENCER

Designation	Gas	Light oil	Heavy oil	Gas/light oil	Gas/heavy oil
KITSIL-260	BLU 700.1 - 1200.1	MAIOR 45 ... 120	OILFLAM 50.1 ... 120.1	MULTICALOR 45 ... 140	MULTIFLAM 50.1 ... 120.1
KITSIL-280	BLU 1500.1 - 2000.1	MAIOR 150.1 - 200.1	OILFLAM 170.1 - 200.1	MULTICALOR 170.1 - 200.1	MULTIFLAM 170.1 - 200.1
KITSIL-320	BLU 3000.1 - 4000.1	MAIOR 300.1 - 400.1	OILFLAM 300.1 - 400.1	MULTICALOR 300.1 - 400.1	MULTIFLAM 300.1 - 400.1
KITSIL-380	BLU 5000.1 - 6000.1	MAIOR 500.1 - 600.1	OILFLAM 500.1 - 600.1	MULTICALOR 500.1 - 600.1	MULTIFLAM 500.1 - 600.1
KITSIL-630	BLU 7000.1 ... 12000.1	MAIOR 700.1 ... 1200.1	OILFLAM 700.1 ... 1200.1	MULTICALOR 700.1 ... 1200.1	MULTIFLAM 700.1 ... 1200.1
KITSIL-710	BLU 15000.1 - 18000.1	MAIOR 1500.1 - 1800.1	OILFLAM 1500.1 - 1800.1	MULTICALOR 1500.1 - 1800.1	MULTIFLAM 1500.1 - 1800.1



Designation	Code
KITSIL-260	3141911
KITSIL-280	3122298
KITSIL-320	3141913
KITSIL-380	3141914
KITSIL-630	3142276
KITSIL-710	3142668

i Expected average reduction in noise level: 5 db
Separate ventilator silencer / silencing box on request

DIAGNOSTIC TOOL FOR ARISTON BURNER CONTROL



Description	Code
TEG111 Diagnostic tool for one stage burners	3142931
PC interface 3.0	3148650

CUSTOMER INTERFACE / KIT DISPLAY



Description	Code
Kit display AZL21 for burners equipped with Siemens LME7	3148779

KIT WIELAND PLUGS

Model	Suitable for	Code
Kit male plug 7 + 4 pins + relay	BLU 700.1 ... 2000.1 PAB	3142034
Kit male plug 7 + 4 pins	BLU/MULTICALOR ... PR	3141932
Kit male plug 7 + 4 pins	MAIOR 45 ... 300.1	3142037

SWIRL SYSTEM



Designation	Gas	Dual fuel (gas/light oil)	Code
KITSWIRL-260	BLU 700.1 - 1200.1	MULTICALOR 45 ... 140	on request
KITSWIRL-280	BLU 1500.1 - 2000.1	MULTICALOR 170.1 - 200.1	on request
KITSWIRL-320	BLU 3000.1 - 4000.1	MULTICALOR 300.1 - 400.1	on request
KITSWIRL-380	BLU 5000.1 - 6000.1	MULTICALOR 500.1 - 600.1	on request
KITSWIRL-630	BLU 7000.1 ... 12000.1	MULTICALOR 700.1 ... 1200.1	on request
KITSWIRL-710	BLU 15000.1 - 18000.1	MULTICALOR 1500.1 - 1800.1	on request

The swirl system for blast tube is applied to reduce the the flame length of the burner. The value of the reduction depends on: boiler back pressure, shape of the combustion chamber, output required.

Estimated length reduction:

- Gas burner: ~ 10/35%
- Dual fuel burners (gas/light oil): ~ 10/25%
- Light oil burners: ~10/25%

! Swirl system for high power burners and for oil burners must be evaluated and developed for each individual application based on feasibility

RWF50

Overall dimensions 48x48mm, IP66, basic controller with:

- 3-position output
- One analog input (actual value)



Model	Code
Kit RWF50 for MAX GAS 70...250 PR	3146829
Kit RWF50 for MAX GAS 350...500 PR with Ariston BCU	3143922
Kit RWF50 for MULTICALOR 45...200 PR-AB	3144025
Kit RWF50 for MAX GAS 350...700 PRE, BLU.3 and MULTICALOR.3, MULTICALOR 500.1/600.1 PR	3147786
Kit RWF50 for all the other models not mentioned above	3143713

i All kits supplied loose; on-board assembly available upon request

RWF55

Overall dimensions 48x96mm, IP66, full version with:

- 3 analog inputs:
 - Analog input 1 (actual value) via thermal elements (J, K, N,...) too;
 - Analog input 2 (external setpoint, setpoint shifting) with resistance thermometer;
 - Analog input 3 (outside temperature) with resistance thermometer (Pt1000 or LG-Ni1000)
- Analog output 4-20mA or 0-10V
- Multi-functional relay "K6" (that could be set for 12 different switching functions)
- Modbus communication via RS-485
- Remote control/setpoint
- Weather-compensated setpoint shifting



Model	Code
Kit RWF55 for MAX GAS 350...700 PRE, BLU.3, BLU 3000.1...18000.1 PR, BLU 7000.1...18000.1 PRE, MULTICALOR 45...600.1 PR and MULTICALOR 170.3...400.3 PR	3147787
Kit RWF55 for MULTICALOR 170.3...400.3 PRE	4396228
Kit RWF55 for all the other models not mentioned above ¹	3143714
Kit RWF55.6 ¹ (PID controller with Profibus communication)	3143830

! ¹: not applicable to MAX GAS with Ariston BCU and to MAX GAS 40...250 with Siemens BCU

i All kits supplied loose; on-board assembly available upon request

TEMPERATURE AND PRESSURE PROBES

Model	Code
Water probe, temperature range from 0 to 130 °C	3122316
Steam probe 0 ... 2 bar	3124100
Steam probe 0 ... 4 bar	3122317
Steam probe 0 ... 10 bar	3122318
Steam probe 0 ... 16 bar	3122319
Steam probe 0 ... 25 bar	3834314
Steam probe 0 ... 40 bar	3122320
Probe for external temperature from -35° to 50 °C	3122315
Hot air or liquid probe, temperature range from -50° to 400 °C	3122314
Thermocouple J type, temperature up to 750 °C (for RWF55 only)	3146725

Description		Code
IP21 with: <ul style="list-style-type: none"> • EMC filter • Inductor • Control panel 	3 kW	3757054
	4 kW	3757055
	5,5 kW	3757056
	7,5 kW	3757057
	11 kW	3757058
	15 kW	3757059
	18,5 kW	3757060
	22 kW	3757061
	30 kW	3757062
	37 kW	3757063
	45 kW	3757064
	55 kW	3757065
	75 kW	3757066
	IP55 with: <ul style="list-style-type: none"> • EMC filter • Inductor • Control panel 	3 kW
4 kW		3757068
5,5 kW		3757069
7,5 kW		3757070
11 kW		3757071
15 kW		3757072
18,5 kW		3757073
22 kW		3757074
30 kW		3757075
37 kW		3757076
45 kW		3757077
55 kW		3757078
75 kW		3757079

GUIDE FOR ELECTRONIC OPTIONS

Required option / Burners with BT300 control	LCM module variant	Frequency converter arrangement	Frequency converter	O ₂ trim kit	O ₂ + CO trim kit	PID load controller kit	Probes	ModBUS/ ProfiBUS KITS
Power modulation with PID controller						•	•	
Frequency converter (installed out of the burner control panel)	•	•	•					
O ₂ control	•			•				
O ₂ + CO control	•				•			
BUS communication	•							•

■ BURNER VARIANTS (options already mounted in factory)

LCM MODULE (for communication via BUS, O₂ control, frequency converter)

Description	Code
Module mounted in factory, required for O ₂ control, frequency converter and communication buses connections Note: only one LCM module is required for these 3 options (already included in dual fuel burners)	3146795

FREQUENCY CONVERTER ARRANGEMENT

Description	Code
Burner prepared to be connected to an external frequency converter Note: this variant includes the VSM module and the Namur speed sensor to control the frequency converter For frequency converter models selection see page 256	on request

! One LCM module is required and must be added separately (already included in dual fuel burners)

■ KITS (supplied loose)

REMOTE SOFTWARE

Description	Code
Kit to connect a PC laptop to the BT300 for its parametrization	LSA100 + USB/CAN + CD-Rom 3751130

COMMUNICATION MODULES

Description	Code	
Additional module for BT3	ModBus/BT3 (EBM102)	3754456
	ProfiBus/BT3 (PBM100)	3752986
	Profinet/BT3 (EBM112)	3758317

O₂ TRIM for BT300, Etamatic and Etamatic OEM

This kit is used to optimize the combustion in order to keep the air excess as much stable as possible irrespective of the changes that can occur during operations, for instance slight calorific value variations, combustion air temperature and pressure. This improves the seasonal efficiency and therefore reduces the fuel consumption.

The kit includes the following components:

- Lambda transmitter LT3
- Lambda probe LS2
- Probe installation fitting (PIF)
- Gas extraction device (GED)

The control unit has to be installed close to the probe (max 10m of cable).

The probe needs a calibration but no reference gas is necessary.

The display shows the O₂ content.

Maximum distance between the LT3 and the burner control panel is 500 meters.

Description	Additional LSB modules installed at LT3	GED length	Code
Kit for O ₂ trim (LT3 + LS2) Flue temp max 300°C - Display for O ₂ visualization	none	150 mm	3759296
		300 mm	3759297
		450 mm	3759298
<div style="background-color: yellow; display: inline-block; padding: 2px;">!</div> For models equipped with BT3 this kit needs a LCM module installed in the burner control panel (already included in dual fuel burners)	4x 0/4-20 mA output	150 mm	3759299
		300 mm	3759300
		450 mm	3759301
	4x 0/4-20 mA output + 4x digital output	150 mm	3759302
		300 mm	3759303
		450 mm	3759304



1. Lambda Probe LS2 in standard housing up to 300°C (572 °F);
default cable: length 2 m (6.5 ft), FEP, with connecting plug
2. Probe installation fitting (PIF)
3. Gas extraction device (GED)
4. Lambda transmitter LT3

The LS2 lambda probe is equipped with a 2 meter long connection cable that connects the sensor to the transmitter (LT3). It is possible to extend the connection up to a maximum distance of 10 meters (for greater lengths the conformity expires) with a ready-made cable and a probe connection box (PCB).

The PCB is a small terminal box that is connected to the 2 meter long cable already existing on the probe. The wiring between the PCB and the transmitter must be carried out on the construction site with suitable cables and trained personnel.

Description	Code
Extension for LS2	5m ready-made cable
	PCB (probe connection box) ¹

! ¹: The PCB is mandatory if the end user chooses to use his own connecting cable and not the one proposed above (maximum total length remains 10m)

O₂ TRIM with CO measure for BT300, Etamatic and Etamatic OEM

This kit is used for optimizing the combustion in order to keep the air excess as low as possible in order to maximize the seasonal efficiency and therefore minimize the fuel consumption. In addition to the features of the O₂ trim only, this kit reduces the air excess to its minimum because this system continuously measures the content of unburned fuel (CO_e) in the flue: should the air excess be reduced too much, the CO_e raises and the system reacts by increasing the air excess in order to keep firing in safe conditions.

The kit includes the following components:

- Lambda transmitter LT3-F
- Lambda probe KS1D
- Probe installation fitting (PIF)
- Gas extraction device (GED)

The control unit has to be installed close to the probe (max 10m of cable).

The probe needs a calibration but no reference gas is necessary.

The display shows the O₂ and CO_e content.

Maximum distance between the LT3-F and the burner control panel is 500 meters.

Description	Additional LSB modules installed at LT3-F	GED length	Code
Kit for O ₂ trim and CO control (LT3-F + KS1D) Flue temp max 300 °C	none	150 mm	3759305
		300 mm	3759306
		450 mm	3759307
 For models equipped with BT3 this kit needs a LCM module installed in the burner control panel (already included in dual fuel burners)	4x 0/4-20 mA output	150 mm	3759308
		300 mm	3759309
		450 mm	3759310
		150 mm	3759311
	4x 0/4-20 mA output + 4x digital output	300 mm	3759312
		450 mm	3759313



1. Lambda Probe KS1D in standard housing up to 300 °C (572 °F); default cable: length 2 m (6.5 ft), FEP, with connecting plug
2. Probe installation fitting (PIF)
3. Gas extraction device (GED)
4. Lambda transmitter LT3-F

The KS1D lambda probe is equipped with a 2 meter long connection cable that connects the sensor to the transmitter (LT3-F). It is possible to extend the connection up to a maximum distance of 10 meters (for greater lengths the conformity expires) with a ready-made cable and a probe connection box (PCB).

The PCB is a small terminal box that is connected to the 2 meter long cable already existing on the probe. The wiring between the PCB and the transmitter must be carried out on the construction site with suitable cables and trained personnel.

Description	Code
Extension for KS1D	5m ready-made cable
	PCB (probe connection box) ¹

 ¹: The PCB is mandatory if the end user chooses to use his own connecting cable and not the one proposed above (maximum total length remains 10m)

SPARE PARTS FOR O₂ AND O₂/CO TRIM

Description		Code
Lambda transmitter LT3	Additional LSB modules installed:	none 4396180 ¹
		4x 0/4-20 mA output 65314636
		4x 0/4-20 mA output + 4x digital output 65314637
Lambda transmitter LT3-F	Additional LSB modules installed:	none 65314641
		4x 0/4-20 mA output 65314638
		4x 0/4-20 mA output + 4x digital output 65314639
LSB modules	4x 0/4-20 mA output	65314642
	4x digital output	65314643
Lambda probes	Lambda probe LS2	4396179 ¹
	Lambda probe KS1D	65314645
Probe installation fitting (PIF)		65314646
Gas extraction device (GED)	GED length 150mm	65314647
	GED length 300mm	65314648
	GED length 450mm	65314649
Wiring adapters ¹	Adapter 655R1027, to adapt a new LS2 with 5-pin round plug to an old LT2/LT3 version with automotive plug	6500790800
	Adapter 655R1028, to adapt an old LS2 version with automotive plug to a new LT3 version with 5-pin round plug	6500791100

i ¹: As of July 2024, the LS2 probe is shipped with a new 5-pin plug, replacing the previous configuration with dual auto plugs. Consequently, the LT3 transmitter has a new plug socket.

For **new installations** refer to the codes with the new configuration on page 260.

In case of an **existing system**:

- to connect a new LS2 probe (code 4396179) to an existing probe connection box, it is necessary to add the adapter 655R1027 (code 6500790800);



- in order to connect the old LS2 probe to a new LT3 transmitter (code 4396180), it is necessary to add the adapter 655R1028 (code 6500791100)





Ecoflam

REGISTERED OFFICE:

Viale A. Merloni, 45
60044 Fabriano (AN)

HEAD OFFICE:

Via Roma, 64
31023 Resana (TV)

Tel.: +39 0423 719500

Fax: +39 0423 719580

Email: export@ecoflam-burners.com

Company subject to the direction and coordination of Ariston Group

Version 2.0 - 19/03/2025

ECOFLAM Bruciatori S.p.A. reserve the right to make any adjustments, without prior notice, which is considered necessary or useful to its products, without affecting their main features.

www.ecoflam-burners.com