

elco

INDUSTRY CATALOGUE





INDUSTRY CATALOGUE

THE COMPANY	_____	p. 4
RANGE OVERVIEW	_____	p. 20
EK-TRON RANGE	_____	p. 36
EK EVO RANGE	_____	p. 66
NEXTRON RANGE	_____	p. 164
N RANGE	_____	p. 232
HO-TRON RANGE	_____	p. 262
GHO-TRON RANGE	_____	p. 282
DUOBLOCK RANGE	_____	p. 296
GAS TRAINS	_____	p. 304
CONTROL UNITS	_____	p. 315
OPTIONS AND ACCESSORIES	_____	p. 317



CUTTING-EDGE BURNERS FOR HEATING AND INDUSTRIAL APPLICATIONS

OUR COMPANY

Since its foundation in 1928, ELCO has always been a specialist in burners conception and manufacturing. By linking a strong innovative ability to a continued developing drive, ELCO has designed high performing and reliable burners as well as corresponding services throughout the years, and is today one of the leaders in the field of combustion technology.



OUR MISSION

ELCO always looks for the best technologies and continues to develop new ones to improve the efficiency of its solutions.

Our R&D Laboratories are committed to develop innovative technological solutions allowing to:

- optimise the running of the installations lowering costs;
- offer service friendly products easy to maintain;
- preserve the environment lowering acoustic and pollutant emissions.



OUR KNOWLEDGE

Your contacts at ELCO and its partners are recognised experts with years of experience. Our worldwide support starts from concept creation to planning, design and project management up to commissioning and on-going operation of the plant throughout its life cycle.

As an ELCO customer, you can count on us for products that guarantee reliability, quality and high performance in any application and working condition.



OUR SERVICE NETWORK

Taking advantage of a staff composed of technicians and engineers with a long experience, ELCO is able to provide professional support to the customer in order to define together the best solution and to develop and manage the project through its entire life-cycle.

ELCO Service activities define the standards in the market and each customer can rely on high performance and reliable products.



OUR INNOVATIVE SOUL

The perfect combination of expertise and inventive spirit provides ELCO the drive to constantly improve its product lines and create new ones to meet market demands, in particular those related to the reduction of polluting emissions.

The growing attention to issues related to the environment has led to the development of advanced combustion technologies that allow NOx emissions to be drastically reduced and which use alternative fuels, as happens for example with hydrogen burners, a product of the future that ELCO is already able to offer today.



OUR ROLE IN THE ENERGY TRANSITION



THE IMPORTANCE OF HYDROGEN IN THE DECARBONIZATION OF THE INDUSTRY

In recent years, decarbonization has become a fundamental issue in our lives, not only for improving the environment but also as a new way of understanding industrial relations and improving our production processes. After many years of intense debate, many countries are now committed to changing the global economy in a climate-friendly way.

In this context, hydrogen shall be deployed as a major future energy source, which is why various development projects are dealing with hydrogen production, transport and storage as well as feeding it into existing gas networks. Hydrogen is thought to be able to provide up to 24% of total energy needs by 2050. This means that in the next few years we will have to deal with the transformation of a large number of plants that consume traditional fuels to make them suitable to work with hydrogen or with mixtures of gases, with hydrogen as the main fuel.

Hydrogen is the most occurring element in the universe and one of the most common elements on earth, where it is bounded in hydrocarbon compounds, in alkaline solutions or in water. However, elemental hydrogen H_2 can be found only in traces in the earth's atmosphere and must be obtained through several processes.

TYPES OF HYDROGEN

 <p>GREY HYDROGEN</p> <p>/ Product of the steam reforming of natural gas (where CO_2 emissions are produced); currently, this represents about 90% of the hydrogen generated for industrial purposes</p>	 <p>BLUE HYDROGEN</p> <p>/ Produced from natural gas, with subsequent storage or disposal of the CO_2 underground/under the seabed (CCS technology)</p>	 <p>GREEN HYDROGEN</p> <p>/ Obtained by (comparatively expensive) electrolysis/power-to-gas processes based on renewable energies</p>
---	--	---

The expected decrease in the cost of electrolyzers and the technological developments in renewable energy technologies will soon create the conditions for large-scale green hydrogen production plants. Consequently, the production of green hydrogen could become easier and more convenient, and in the future become a way to manage, store and reuse energy produced from renewable sources:

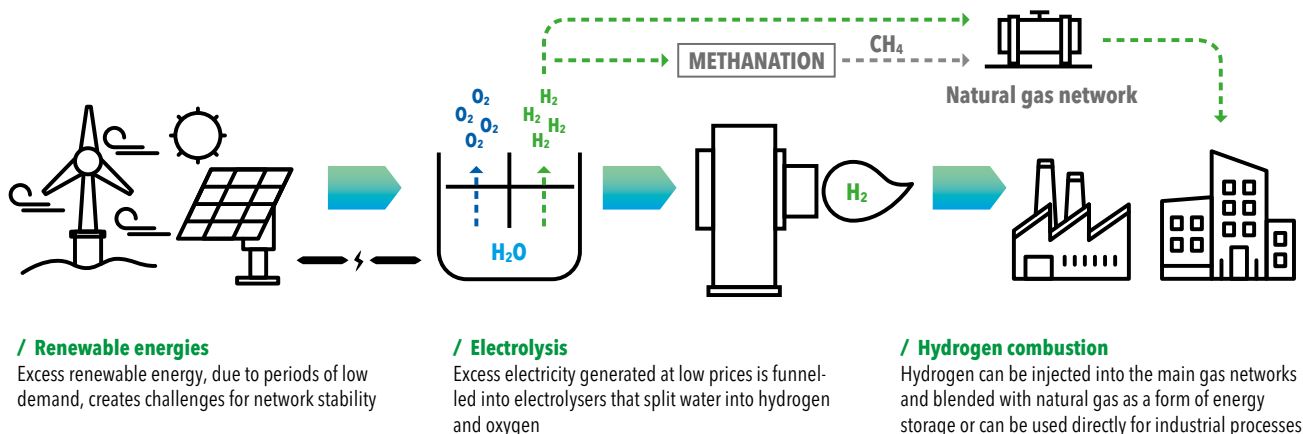

Compared with natural gas, hydrogen has several peculiar characteristics:

- it is colorless, odorless and tasteless;
- it is around 8 times lighter and can volatilize very quickly through porous materials or through the smallest leaks;
- the calorific value is lower by a factor of 3/3,5 than most commercially available natural gases;
- it has an extremely wide flammability range and the flame (almost invisible) burns about 8 times faster than natural gas;
- it needs 15 times less spark energy for ignition than natural gas and ignition speed is about 7 times higher.

The theoretical replacement of natural gas with hydrogen within a system causes enormous changes in the air demand, flame temperature, combustion quality, power output and, due to the different density, also regarding gas pressure losses.

For all these reasons, integrate hydrogen into the energy mix requires a huge experience and specific know-how.

OUR EXPERIENCE WITH HYDROGEN

HYDROGEN BURNERS

Green combustion technologies ready for the future



ELCO has been manufacturing Low NOx combustion systems for several decades and can count on a strong expertise also with hydrogen applications, developed by our R&D Department since the 90s. Thanks to the know-how developed on the field, ELCO is one of the few suppliers in the world that can already offer safe, reliable and performing Low NOx hydrogen burners, guaranteeing excellent results in terms of emission level, flame stability and energy efficiency.

INSTALLATION REFERENCES WITH HYDROGEN BURNERS

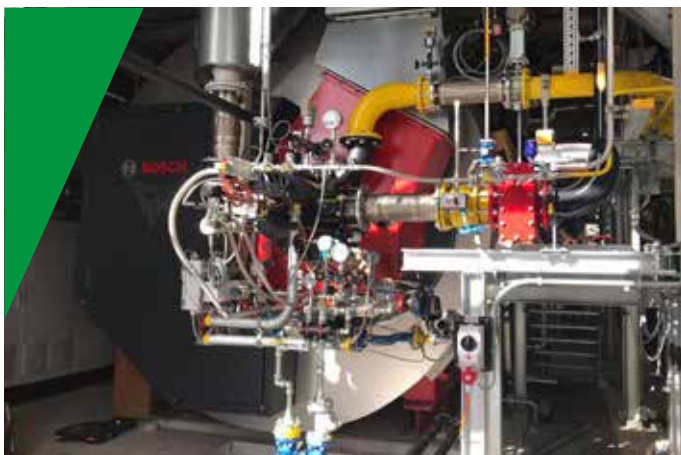

Location: Switzerland
Fuels: hydrogen, natural gas, light oil
 H₂ pressure: 500 mbar
Maximum power output: 13,6 MW
Burner: RPD 70 GGL-EU1-So
 Hot air version (130°C), IP65, FGR System



Location: Jordan
Fuel: hydrogen, natural gas, heavy oil
Maximum power output: 6,2 MW
Burner: RPD 30 GS-ED-So
 Hot air version (270°C), IP54

Burner	Fuels	Country	Date
RPD 30	H ₂ / Natural gas	China	1995
RPD 30	H ₂ / Heavy oil	China	1996
RPD 60	H ₂ / Natural gas	China	1996
RPD 60	H ₂ / Heavy oil	China	2002
RPD 20	H ₂ / Light oil	Saudi Arabia	2003
RPD 60	H ₂ / Heavy oil	China	2004
RPD 30	H ₂ / Heavy oil	India	2005
RPD 60	H ₂ / Heavy oil	China	2005
RPD 60	H ₂ / Natural gas	Taiwan	2006
RPD 70	H ₂ / Heavy oil	China	2006
RPD 40	H ₂ / Heavy oil	India	2007
RPD 60	H ₂ / Natural gas	India	2008
RPD 40	H ₂ / Heavy oil	India	2008
EK-DUO 2.550	H ₂	Belgium	2008
RPD 40	H ₂ / Heavy oil	India	2010
RPD 30	H ₂ / Heavy oil	India	2010
RPD 30	H ₂ / Heavy oil	Syria	2010
RPD 50	H ₂	China	2010
RPD 30	H ₂ / Natural gas	India	2010
RPD 40	H ₂ / Natural gas	India	2011
RPD 30	H ₂ / Heavy oil	India	2011
RPD 30	H ₂ / Natural gas	Belgium	2012
RPD 50	H ₂ / Natural gas	China	2012
RPD 40	H ₂ / Natural gas	India	2012
RPD 50	H ₂ / Natural gas	China	2013
RPD 60	H ₂ / Natural gas / Carbide gas	China	2013
RPD 80	H ₂ / Light oil	Qatar	2013
RPD 30	H ₂ / LPG	India	2014
RPD 30	H ₂ / Heavy oil	Indonesia	2014
RPD 30	H ₂ / LPG	India	2015
RPD 70	H ₂ / Coke gas / Carbide gas	China	2015
RPD 40	H ₂ / Natural gas	Kuwait	2016
RPD 30	H ₂ / Heavy oil	Jordan	2017
RPD 50	H ₂ / Heavy oil	India	2017
RPD 50	H ₂ / Heavy oil	India	2017
RPD 40	H ₂ / Heavy oil	India	2018
RPD 70	H ₂ / Natural gas / Light oil	Switzerland	2019
RPD 70	H ₂ / Natural gas / Light oil	Taiwan	2019
RPD 70	H ₂ / Natural gas	Taiwan	2019
RPD 40	H ₂ / Natural gas / Heavy oil	Saudi Arabia	2019
RPD 50	H ₂ / Natural gas	India	2019

TECHNICAL ASSISTANCE

For safe and efficient operation of your burner system it is very important that the burner is commissioned by a competent person. The combustion will be optimally adjusted over the whole power range of the burner, and all the safety devices will be tested.

To keep your installation in good conditions, it is important to maintain the burner periodically. It is also very important to inspect all the safety devices to ensure that your system operates safely.

Fortunately, you can rely on the professional services of ELCO which can perform this service for you.



BURNER ACADEMY

In order to respond to the needs of our customers we created a Burner Academy, a real training school where the knowledge of our technicians is passed on to our trainees.

We provide the opportunity for boiler room personnel, operators and engineers to attend a series of training sessions carried out on our test bench by highly qualified instructors, who hold the courses in English, German, French, Italian and Dutch language.

The Burner Academy uses various training locations where boilers are installed and where people can be trained in theory and in practice. We offer courses at different levels and also the possibility to handle all your needs in a customer-specific training.



RELIABLE SUPPLY OF SPARE PARTS

Spare parts have always had a great importance inside the ELCO world. Considering the high amount of parts involved in every single product, some of these parts might naturally need to be replaced. ELCO can count on an International network offering original spare parts in order to guarantee the highest quality, reliability and safe continued operation of the appliance.

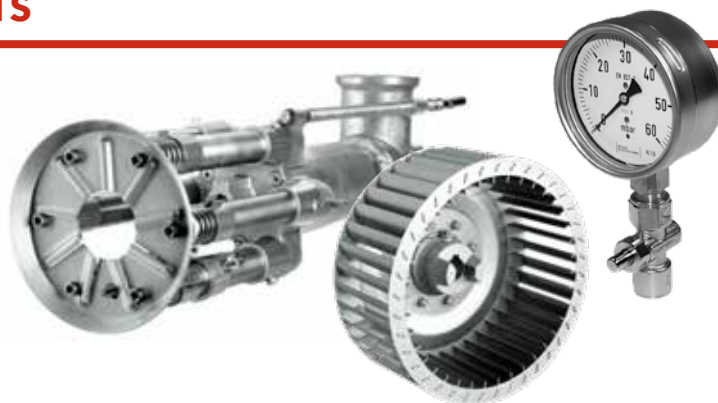

WORLDWIDE NETWORK

Capitalising on almost 100 years of work experience, ELCO has been capable to build up loyal partnerships and today can count on reliable Partners all over the World.

Combining an instinctively global perspective with a genuinely multicultural approach ELCO today offers you skilled and experienced experts available in more than 70 Countries.

- 3 production plants
- 6 commercial branches in Europe
- 2 Sales Offices in Dubai and China
- Distribution in more than 70 Countries
- Strong commercial presence through a network of reliable dealers and partners

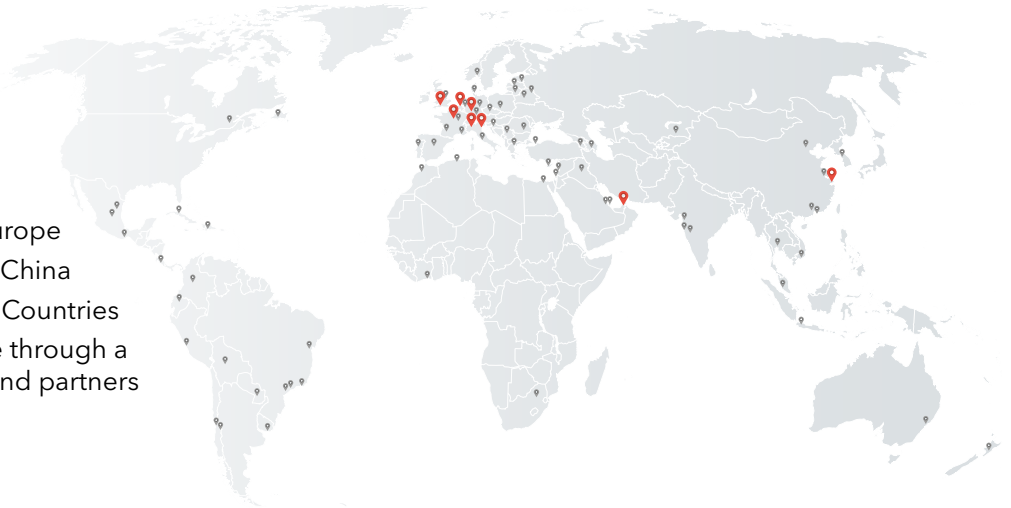

Service Network

In Western Europe, ELCO has a well organised service network. Outside Western Europe ELCO uses a network of partners, consisting of well-trained local engineers, to carry out its service operations. These technicians are able to perform both commissioning and local service and they do it in a very professional and efficient way.

ELCO ON THE WEB

We are constantly looking forward to provide to our customers new technologies, products and services. Stay always up to date on the latest news from the ELCO World visiting our website:

www.elco-burners.com

Navigate to explore the ELCO proposal and choose the perfect product to fit your needs, and follow us to know more about our new activities and projects.

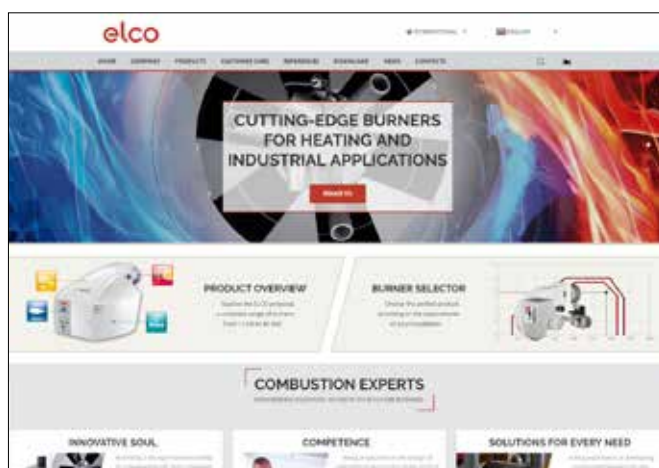

ELCO SYSTEMS AND TECHNOLOGIES

To constantly improve its products, ELCO is committed to develop innovative technological solutions allowing to optimise the running of the installations, to ease technicians work, and naturally to preserve the environment. In order to provide quick responses to its market's demands, the range of ELCO burners is entirely conceived around a consistent combination of Systems.

MDE2 SYSTEM

Permanent communication of information easy to use



Equipped with the MDE2 System, the universal language Elcogram and the 5-button keyboard, ELCO burners adjust themselves and constantly communicate to the technicians and operators:

- real time information about each ignition and during the running;
- statistical information about burner operations recorded during the year before the maintenance operations.

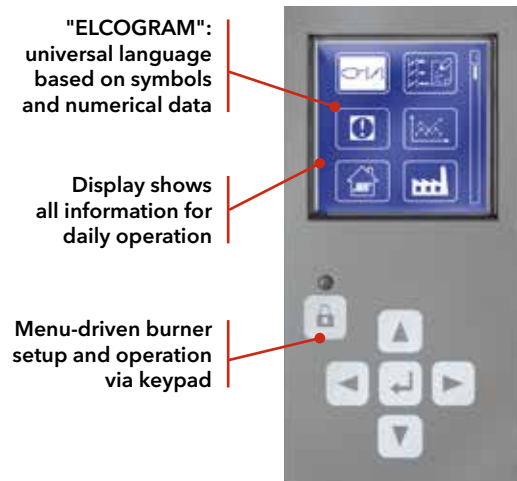

"ELCOGRAM":
universal language
based on symbols
and numerical data

Display shows
all information for
daily operation

Menu-driven burner
setup and operation
via keypad

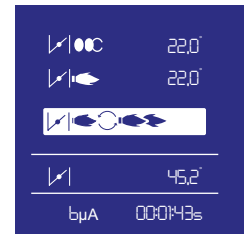

Elcogram, a universal language
As ELCO products are distributed worldwide, the company has developed a universal language composed of pictograms and numerical data. The pictograms use the majority of the symbols used on the wiring diagrams which are recognised and understood by all Nations. This ensures that information is easier to read than ever before.

CMS SYSTEM

The evolution of combustion management systems



CMS is a state of the art system for burner management that sets new standards in control automation. The system provides a full combustion management solution that meets all relevant safety standards, and is certified for all main markets and Standards. CMS system is simple and easily configurable to meet a wide range of application requirements, from low cost to high end solutions, for industrial or residential applications. The CMS grants efficient communication via BUS and is extremely flexible due to the fact that is fully configurable, fully compatible with external devices/systems and fully scalable, allowing additional functions, such as VSD fan control, oxygen trim and CO control. A wide number of interfaces are available, from low-cost keypad to high-resolution touchscreens, allowing intuitive and easy interaction between user and machine.



GEM SYSTEM

Electronic burner control: high safety and low costs



The use of electronic technologies in burner control systems helps to reduce running costs, improve reliability of operation and lower pollutant emissions.

The electronic combustion manager used on ELCO burners are responsible not only for the burner control but also for the fuel/air regulation. Data stored electronically has replaced the mechanical characteristic curve and help to achieve an unprecedented level of precision in air/fuel ratio regulation across the burner's entire control range, a pre-requisite for efficient, energy- and cost-saving operation.

An additional advantage of the GEM is that it provides specific information on all the commands and current situation of the overall system: these can be accessed directly or by remote control.

The digital programming is user-friendly, it is carried out through the display of the MDE2 System or through a PC by using a simple procedure facilitated by easy instructions in a clear language.

VARIATRON

Speed regulation: noise reduction and energy saving



To improve the performance of heating or industrial systems, ELCO applies Variatron (fan speed control).

Conventionally, the air in modulating burners is regulated by an air flap. In the partial load range, a large amount of the air pressure generated by the ventilator goes to waste. With speed regulation, the speed of the combustion/air fan is varied continuously depending on the burner output required: full speed is reached only at maximum burner output. In the predominant partial load range, lower speed translates into significant reductions in power consumption and noise emissions.

The Variatron operates in step with the air damper both with the GEM System, which guarantees a combustion with minimum air excess by continuously monitoring all operating conditions.

Application of the Variatron to ELCO burners results in:

- electrical consumption savings in the order of 50%;
- turndown ratio of up to 1:10, resulting in perfect adaptation to system requirements and improvement in average seasonal efficiency, in particular with condensing or low-temperature boilers or specific processes;
- silent start-up and average overall noise reduction between 2 and 12 dB(A) (at minimum and maximum power).

RTC SYSTEM

Rapid and easy maintenance solutions



The functional housing design of all ELCO burners, combined with the innovative combustion head technologies, creates the RTC System (Retained Head Adjustment) and provides the user with several advantages:

- full access to all components, by simply removing the upper cover;
- complete removal of the combustion head and access to its internal components with a single operation, without removing the burner from the boiler or disconnecting the gas train;
- maintenance of the adjustments made to the combustion head, which are not changed during service operations;
- quick cleaning of mechanical components, thanks to their optimized arrangement;
- reduced servicing times through the use of standard nuts, bolts, screws and pipe fittings, which can be adjusted using only a few tools.

The combination of all these technical solutions makes it possible to simplify and speed up all the operations carried out on the burner, reducing downtime and cost of maintenance.

COMBUSTION TECHNOLOGIES

FREE FLAME (F3, UF)

The pinnacle of low-polluting burner engineering



The Free Flame combustion technology is based on the internal recirculation of the flue gas, combined with high speed flow of the fuel air mixture.

The flame stabilizes at a certain distance from the combustion head, thus leaving space for the mixture of reagents and flue gas.

This phenomenon greatly reduces NOx emissions. The flame seems to float in the furnace, thus giving the system its name: «Free Flame».

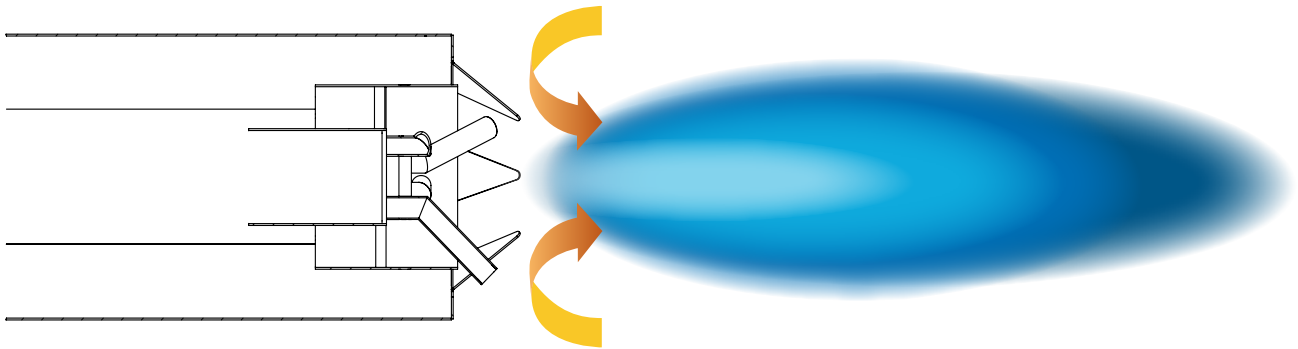

DIAMOND HEAD (U2, U2N, U3)

Low emissions and reliable operation



The principle of Diamond Head technology is based on the internal recirculation of the combustion flue gases. The gases are partially drawn into the base of the flame via triangular openings placed at the end of the combustion head.

The position and geometry of the gas injectors are such that a significant quantity of combustion flue gas is drawn in and rapidly mixed with air and gas at the root of the flame. This mixture crosses the main reaction area, slowing the combustion, which results in lowering the main flame temperature. The result of this staging combustion is a significant reduction in the formation of thermal nitrogen oxides.

The advantage of this internal recirculation technique is an automatic adjustment to the quantity of recycled combustion flue gases: the volume of the flame is always as low as possible, which has a very minor effect on the nominal power of the generator, unlike external recirculation systems.



COMBUSTION TECHNOLOGIES

MULTI-STAGE HEAD (X2)

Clean emissions and flame stability



The principle of the Multi-Stage combustion head is based on the separation of the flame in multiple areas. The result of this process is a significant reduction of the temperature of the flame and, as a direct consequence of this, a drop of the NO_x emission.

The implementation of this technology does not result only in lowering the pollutant emissions but also assure a very stable flame in all operation conditions.

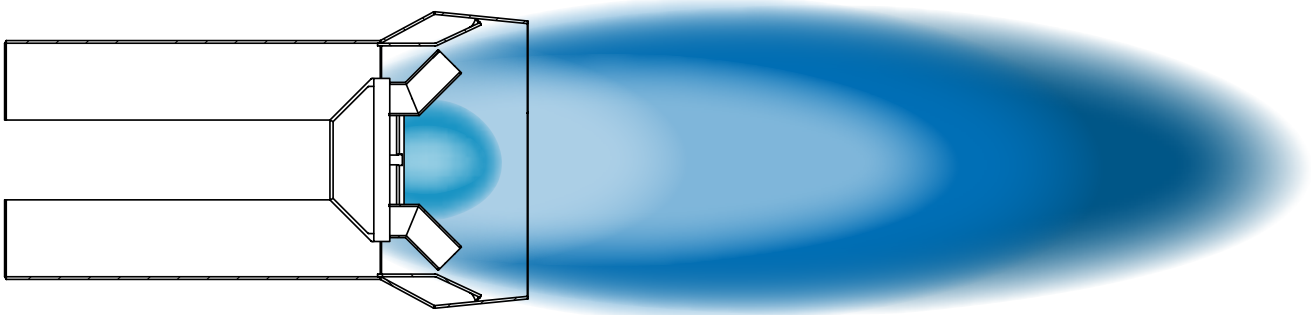

BLUE TRIPLE HEAD (FX)

Extreme low NO_x values and high flame stability



The principle of the "Blue Triple Head" is based on a stage combustion combined with an internal recirculation of the combustion flue gases.

Multi-Stage Combustion allows stable nucleus flame and highest internal flue gas recirculation in next stage.

The result is a very low NO_x value, a CO tending to 0 and a high stability that guarantee the limits even in standard combustion chambers.



FGR SYSTEM

Ultra low NOx solutions to reach emissions of less than 30 mg/kWh



ELCO has an enormous experience in the application of low emissions systems, going back to the early 90s, when the first Low NOx installation have been successfully commissioned.

Thanks to this experience and the technologies developed over the years, ELCO offers a wide range of products which use the external FGR technology to reduce NOx emissions and satisfy even the most stringent regulations.

The external recirculation sends a mixture of air and flue gas to the burner combustion head. The gases are mixed upline of the combustion process by the burner fan (for monoblock units) or by the external fan (in case of duoblock burners).



Functional scheme on monoblock burners

The FGR system on monoblock burners provides that the flue gas is drawn in by the burner fan. The installer must therefore install a line connecting the flue gas outlet to the burner fan inlet.

The extraction point is generally at the base of the flue pipe, where the pressure is close to zero. A suction is generated in the burner intake box which is a function of the fan curve and the air damper position.

In order to ensure an adequate rate of flue gas from the stack and thus to provide the required NOx reduction, the pipeline between the flue and the burner must be sized to minimise the pressure drop.

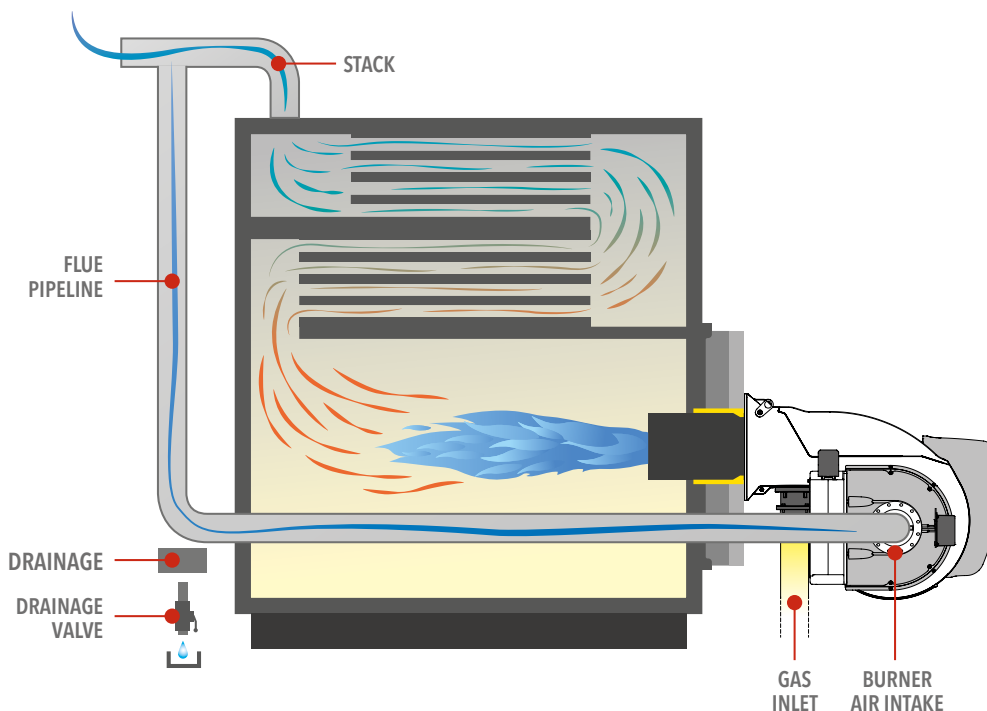

Functional scheme on duoblock burners - Layout «A»

The FGR system for duoblock burners, since the draught fan is installed far from the burner, needs a layout different from the one of the monoblock ones. On such a layout, the flue duct ends upstream of the draught fan. In order to produce the needed suction to get flue from the stack and to mix it with the fresh air, the air damper is fitted upstream of the draught fan and upstream of the flue duct end, too.

As for monoblock burner, the flue duct has to be properly sized in order to minimize the pressure drop.

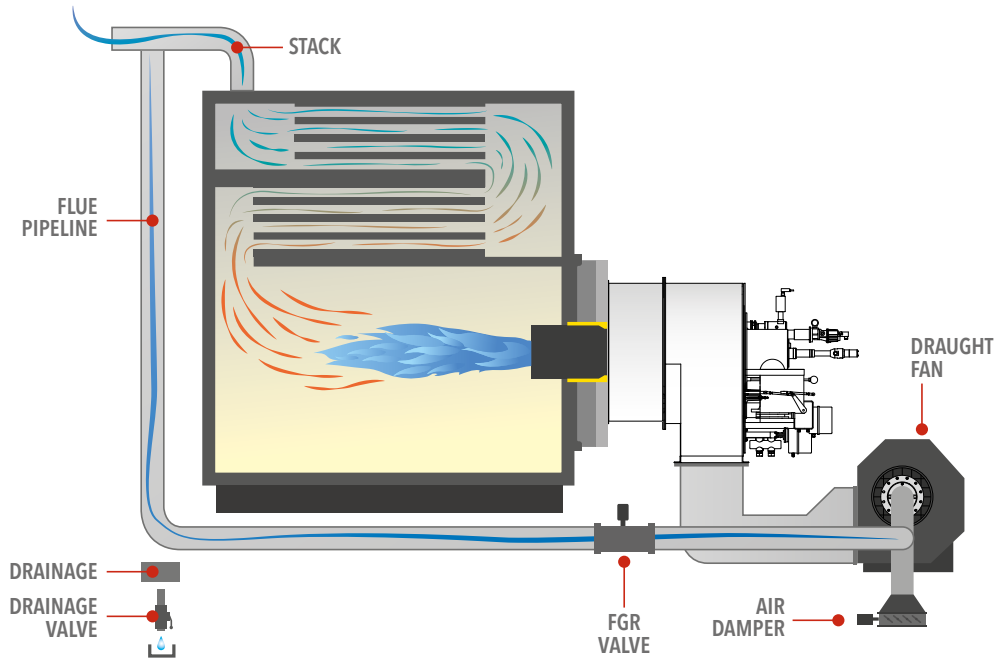

Functional scheme on duoblock burners - Layout «B»

An alternative layout to layout «A» provides a further draught fan dedicated to the flue. It takes the flue from the stack and pushes it into the duct between the burner and the fresh air draught fan. The flue damper is just after the flue fan. The air damper is on burner board and therefore it adjusts the rate of the mixture between the flue and the fresh air.

As for monoblock burner, the flue duct has to be properly sized in order to minimize the pressure drop.

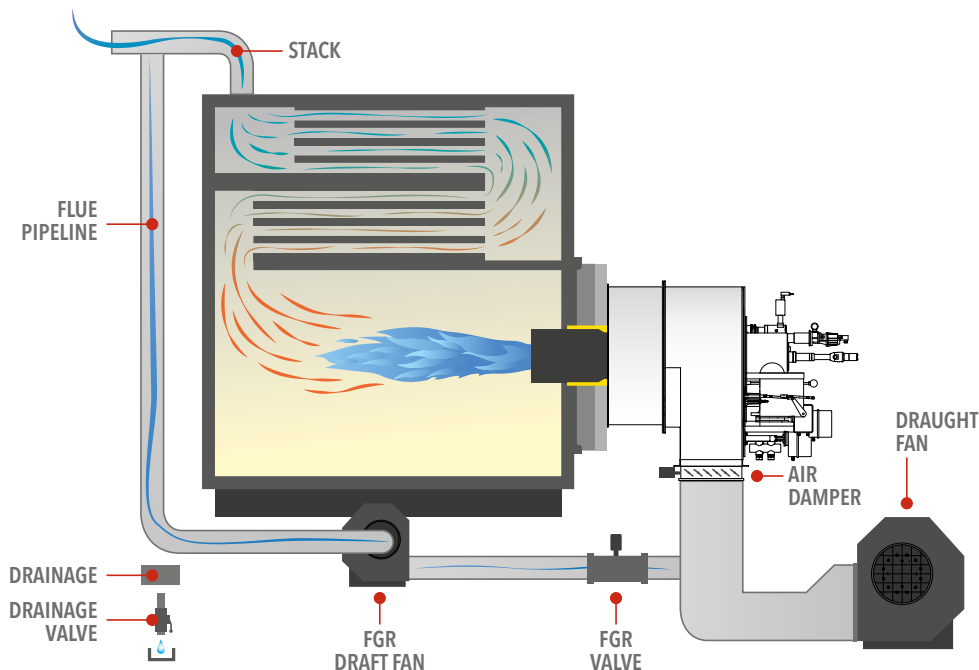

WORLDWIDE REFERENCES

Altchemnitz, Germany

Burners:

6x N11.22000 G-EU1

Total nominal output:

132 MW

Emissions:

NO_x <80 mg/kWh



Bialystok, Poland

Burners:

2x RPD 70 G-EU2

Total nominal output:

41 MW

Emissions:

NO_x <80 mg/kWh



Beijing, China

Burners:

2x N10.16000 G-EU2 FGR

Total nominal output:

32 MW

Emissions:

Installation with FGR system to reach
NO_x values below 30 mg/kWh



WORLDWIDE REFERENCES

Xining, China

Burners:
12x RPD N 70 G-EU1 FGR

Total nominal output:
252 MW

Emissions:
Installation with FGR system to reach
NOx values below 30 mg/kWh



Seoul, South Korea

Burners:
7x N8.7100 G-EU3

Total nominal output:
50 MW

Emissions:
NOx <80 mg/kWh



Stavanger, Norway

Burners:
2x EK-DUO 4.1600 G-E

Total nominal output:
32 MW

Emissions:
NOx <80 mg/kWh



WORLDWIDE REFERENCES

Rostock, Germany

Burners:

2x RPD 90 G-EFX

Total nominal output:

65 MW

Emissions:

NOX <60 mg/kWh



Zhangjiakou, China

Burners:

Plant 1: 2x RPD 160 G EU1 FGR

1x RPD 130 G EU1 FGR

Plant 2: 2x RPD 130 G EU1 FGR

Total nominal output:

355 MW

Emissions:

Installation with FGR system to reach
NOx values below 30 mg/kWh



Seoul, South Korea

Burners:

3x N10.16000.45 G-EU2 FGR

1x N10.12000.37 GL-EUF

Total nominal output:

80 MW

Emissions:

NOx <80 mg/kWh



WORLDWIDE REFERENCES

Beijing, China

Burners:

2x RPD N 90 G-EU1 FGR
2x RPD N 130 G-EU1 FGR

Total nominal output:

87 MW

Emissions:

Installation with FGR system to reach
NOx values below 30 mg/kWh



Monza, Italy

Burners:

1x N11.19000 G-EU2

Total nominal output:

19 MW

Emissions:

Installation with FGR system to reach
NOx values below 30 mg/kWh



Beijing, China

Burners:

1x EK EVO 8.5800 G-EU3 FGR
2x EK EVO 8.7100 G-EU3 FGR

Total nominal output:

21 MW

Emissions:

Installation with FGR system to reach
NOx values below 30 mg/kWh



OUR PRODUCT RANGE

Our experience at combustion technology available in a complete range of burners from 11 kW to 80 MW:

Monoblock range:



VECTRON
11 - 2300 kW
 Gas
 Light oil
 Dual fuel
 Biofuel



PROTRON
15 - 550 kW
 Gas
 Light oil



EK-TRON
320 - 6050 kW
 Gas
 Dual fuel



NEXTRON
250 - 11200 kW
 Gas
 Light oil
 Dual fuel



EK EVO
250 - 13500 kW
 Gas
 Light oil
 Dual fuel



N
1300 - 22000 kW
 Gas
 Light oil
 Dual fuel



HO-TRON
68 - 17000 kW
 Heavy oil



GHO-TRON
414 - 17000 kW
 Heavy oil
 Dual fuel

Duoblock range:



D-TRON
230 - 42000 kW
 Gas
 Light oil
 Gas / light oil
 Heavy oil
 Gas / heavy oil



EK-DUO
600 - 16000 kW
 Gas
 Light oil
 Dual fuel



RPD N
3000 - 80000 kW
 Gas



RPD
500 - 80000 kW
 Gas
 Light oil
 Gas / light oil
 Heavy oil
 Gas / heavy oil

TWO STAGE PROGRESSIVE/MODULATING ELECTRONIC / Low NOx

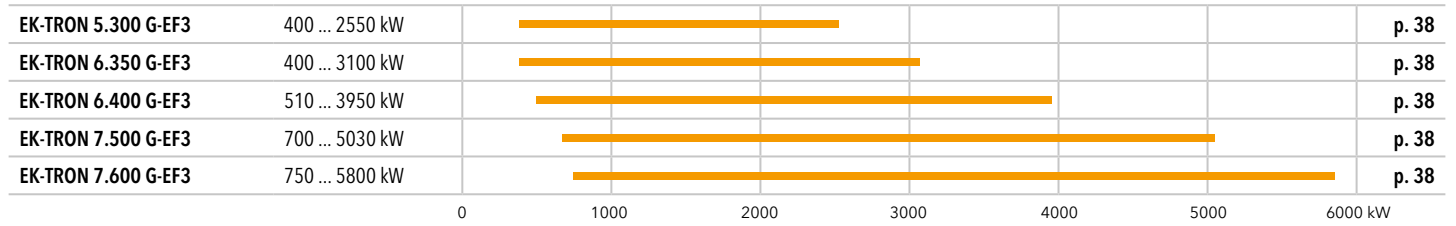

TWO STAGE PROGRESSIVE/MODULATING MECHANICAL / Low NOx

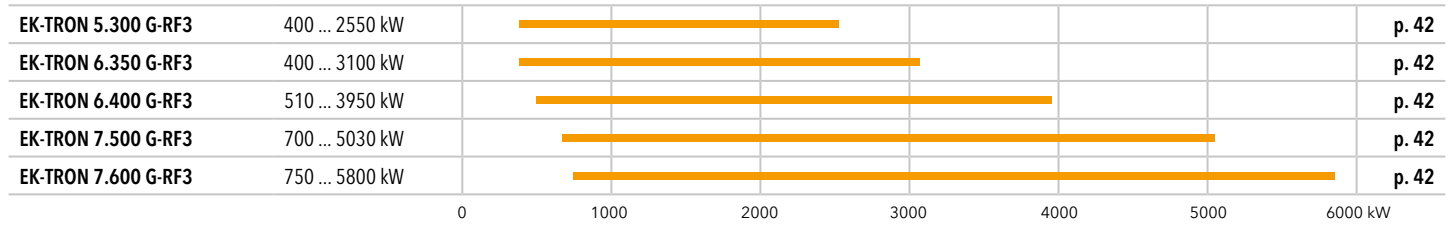



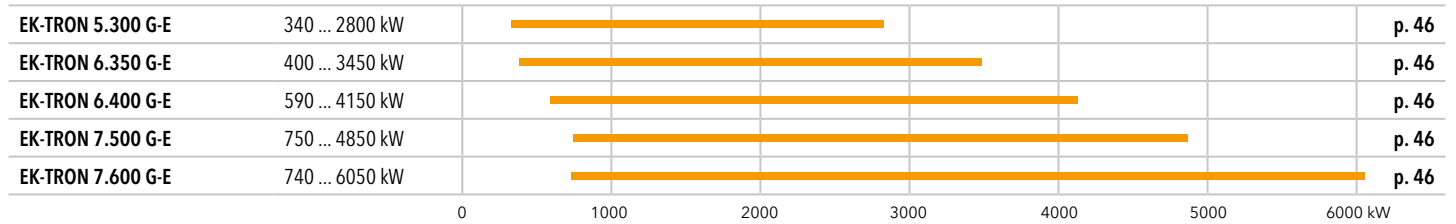

TWO STAGE PROGRESSIVE/MODULATING ELECTRONIC

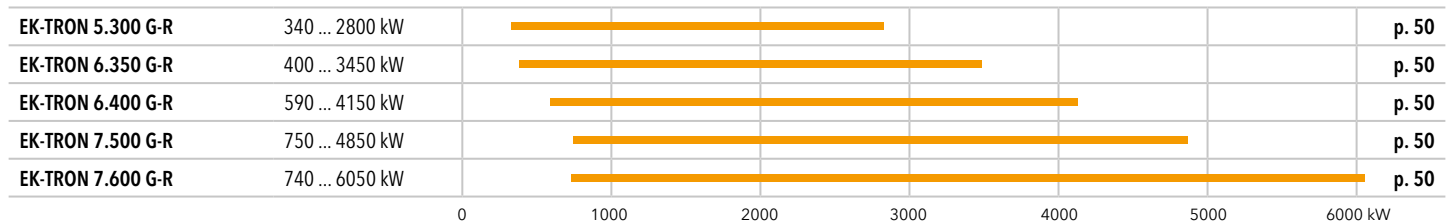

TWO STAGE PROGRESSIVE/MODULATING MECHANICAL

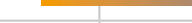

TWO STAGE PROGRESSIVE/MODULATING ELECTRONIC / Low NOx

EK-TRON 5.170 GL-EX2	320 ... 1800 kW		p. 54
EK-TRON 5.200 GL-EX2	340 ... 2160 kW		p. 54
EK-TRON 6.350 GL-EX2	610 ... 3200 kW		p. 58
EK-TRON 6.400 GL-EX2	600 ... 3900 kW		p. 58

0 1000 2000 3000 4000 5000 6000 kW

BURNER VARIANTS [p. 62](#)

BURNER KITS [p. 63](#)

TWO STAGE PROGRESSIVE/MODULATING ELECTRONIC / **ULTRA Low NO_x** (FX burner head)

EK EVO 7.4000 G-EFX	440 ... 4040 kW		p. 68
EK EVO 8.6600 G-EFX	730 ... 6610 kW		p. 68
EK EVO 9.7200 G-EFX	890 ... 7200 kW		p. 72
EK EVO 9.9400 G-EFX	980 ... 9440 kW		p. 72
EK EVO 9.11300 G-EFX	1250 ... 11350 kW		p. 72

TWO STAGE PROGRESSIVE/MODULATING ELECTRONIC / **Low NO_x** (F3/U3 burner head)

EK EVO 6.2400 G-EF3	340 ... 2500 kW		p. 76
EK EVO 6.2900 G-EF3	340 ... 2900 kW		p. 76
EK EVO 7.3600 G-EF3	470 ... 3980 kW		p. 80
EK EVO 7.4500 G-EF3	510 ... 4290 kW		p. 80
EK EVO 7.5800 G-EF3	620 ... 5500 kW		p. 80
EK EVO 7.7000 G-EU3	610 ... 7450 kW		p. 84
EK EVO 8.5800 G-EU3	600 ... 6070 kW		p. 88
EK EVO 8.7100 G-EU3	700 ... 7700 kW		p. 88
EK EVO 9.8700 G-EU3	850 ... 8530 kW		p. 88
EK EVO 9.10400 G-EU3	910 ... 10500 kW		p. 88
EK EVO 9.13000 G-EU3	1350 ... 13500 kW		p. 92

TWO STAGE PROGRESSIVE/MODULATING ELECTRONIC / **Low NO_x** (U2/U2N burner head)

EK EVO 6.2200 G-EU2N	360 ... 2380 kW		p. 96
EK EVO 6.2400 G-EU2	360 ... 2530 kW		p. 100
EK EVO 6.2900 G-EU2	365 ... 3050 kW		p. 100
EK EVO 7.3400 G-EU2N	530 ... 3720 kW		p. 96
EK EVO 7.3600 G-EU2	490 ... 4290 kW		p. 104
EK EVO 7.4500 G-EU2	510 ... 4290 kW		p. 104
EK EVO 7.5800 G-EU2	630 ... 5850 kW		p. 104
EK EVO 9.7200 G-EU2N	1070 ... 8020 kW		p. 108
EK EVO 9.7500 G-EU2N	1050 ... 8300 kW		p. 108
EK EVO 9.13000 G-EU2	1700 ... 13000 kW		p. 112

TWO STAGE PROGRESSIVE/MODULATING ELECTRONIC

EK EVO 6.2400 G-E	390 ... 2650 kW		p. 116
EK EVO 6.2900 G-E	400 ... 3200 kW		p. 116
EK EVO 7.3600 G-E	580 ... 4300 kW		p. 116
EK EVO 7.4500 G-E	680 ... 5400 kW		p. 116
EK EVO 8.5800 G-E	620 ... 6570 kW		p. 120
EK EVO 8.7100 G-E	610 ... 8150 kW		p. 120
EK EVO 9.8700 G-E	780 ... 9700 kW		p. 120
EK EVO 9.10400 G-E	850 ... 11230 kW		p. 120

TWO STAGE PROGRESSIVE/MODULATING ELECTRONIC IN GAS AND IN LIGHT OIL / Low NOx

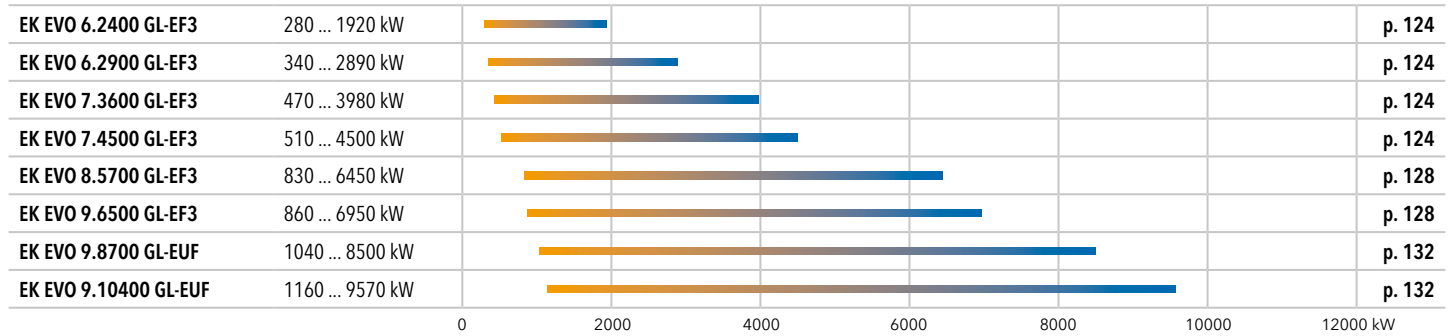

TWO STAGE PROGRESSIVE/MODULATING ELECTRONIC IN GAS / THREE STAGES IN LIGHT OIL

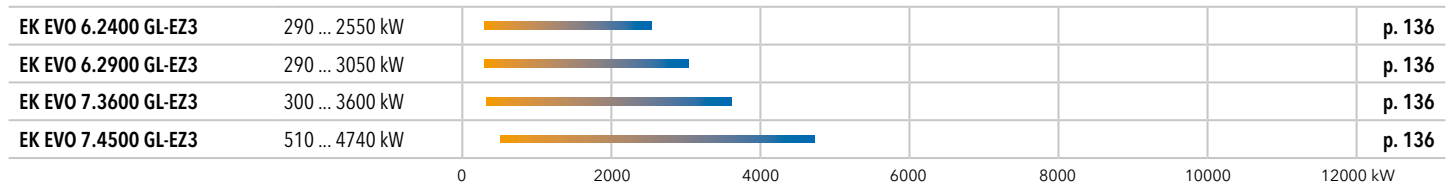

TWO STAGE PROGRESSIVE/MODULATING ELECTRONIC IN GAS AND IN LIGHT OIL

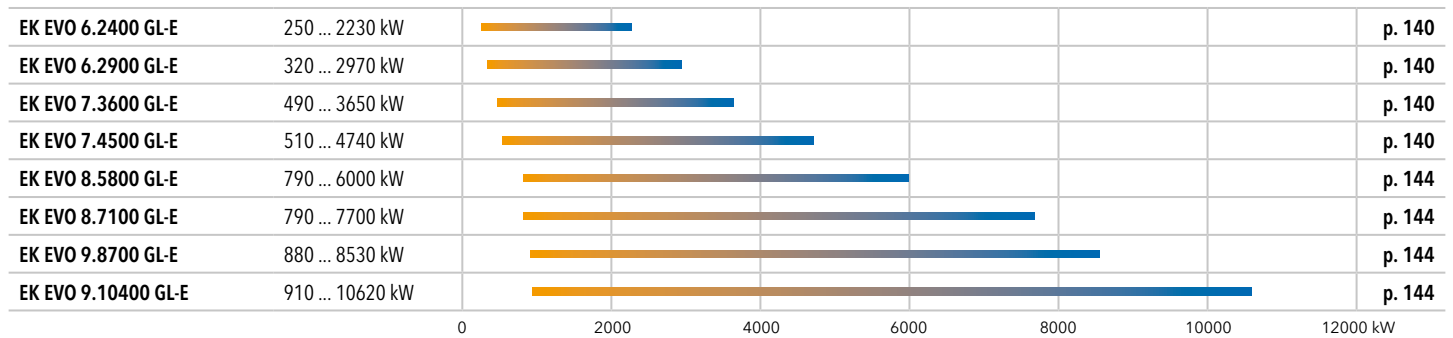

TWO STAGE PROGRESSIVE/MODULATING ELECTRONIC / Low NOx

EK EVO 6.2400 L-EF3	360 ... 1850 kW		p. 148
EK EVO 6.2900 L-EF3	480 ... 2950 kW		p. 148
EK EVO 7.3600 L-EF3	680 ... 4070 kW		p. 148
EK EVO 7.4500 L-EF3	740 ... 4820 kW		p. 148
EK EVO 8.5700 L-EF3	1100 ... 6450 kW		p. 150
EK EVO 9.6500 L-EF3	1200 ... 6600 kW		p. 150
EK EVO 9.8700 L-EUF	1800 ... 8500 kW		p. 152
EK EVO 9.10400 L-EUF	2550 ... 9570 kW		p. 152

TWO STAGE PROGRESSIVE/MODULATING ELECTRONIC

EK EVO 6.2400 L-E	510 ... 2030 kW		p. 154
EK EVO 6.2900 L-E	650 ... 3100 kW		p. 154
EK EVO 7.3600 L-E	900 ... 3850 kW		p. 154
EK EVO 7.4500 L-E	1300 ... 4900 kW		p. 154
EK EVO 8.5800 L-E	1210 ... 6100 kW		p. 156
EK EVO 8.7100 L-E	1450 ... 7700 kW		p. 156
EK EVO 9.8700 L-E	2400 ... 8530 kW		p. 156
EK EVO 9.10400 L-E	2820 ... 10620 kW		p. 156

BURNER VARIANTS [p. 158](#)BURNER KITS [p. 160](#)SPECIAL CONFIGURATIONS [p. 163](#)

TWO STAGE PROGRESSIVE/MODULATING ELECTRONIC / **ULTRA Low NO_x** (FX burner head)

N7.4000 G-EFX	440 ... 4040 kW		p. 166
N8.6600 G-EFX	730 ... 6610 kW		p. 166
N9.7200 G-EFX	890 ... 7200 kW		p. 170
N9.9400 G-EFX	980 ... 9440 kW		p. 170

TWO STAGE PROGRESSIVE/MODULATING ELECTRONIC / **Low NO_x** (F3/U3 burner head)

N6.2400 G-EF3	340 ... 2300 kW		p. 174
N6.2900 G-EF3	360 ... 2850 kW		p. 174
N7.3600 G-EF3	500 ... 3900 kW		p. 174
N7.4500 G-EF3	600 ... 4200 kW		p. 174
N8.5800 G-EU3	640 ... 5800 kW		p. 178
N8.7100 G-EU3	700 ... 7100 kW		p. 178
N9.8700 G-EU3	850 ... 8530 kW		p. 178
N9.10400 G-EU3	900 ... 10200 kW		p. 178

TWO STAGE PROGRESSIVE/MODULATING ELECTRONIC / **Low NO_x** (U2/U2N burner head)

N6.2200 G-EU2N	350 ... 2300 kW		p. 182
N6.2400 G-EU2	340 ... 2500 kW		p. 186
N6.2900 G-EU2	340 ... 2900 kW		p. 186
N7.3400 G-EU2N	490 ... 3700 kW		p. 182
N7.3600 G-EU2	490 ... 4290 kW		p. 186
N7.4500 G-EU2	510 ... 4290 kW		p. 186
N9.7200 G-EU2N	970 ... 7840 kW		p. 190
N9.7500 G-EU2N	1020 ... 8250 kW		p. 190

TWO STAGE PROGRESSIVE/MODULATING ELECTRONIC

N6.2400 G-E	390 ... 2500 kW		p. 194
N6.2900 G-E	400 ... 3000 kW		p. 194
N7.3600 G-E	580 ... 4100 kW		p. 194
N7.4500 G-E	680 ... 5000 kW		p. 194
N8.5800 G-E	740 ... 6570 kW		p. 198
N8.7100 G-E	800 ... 7800 kW		p. 198
N9.8700 G-E	880 ... 9200 kW		p. 198
N9.10400 G-E	960 ... 11200 kW		p. 198

TWO STAGE PROGRESSIVE/MODULATING ELECTRONIC IN GAS AND IN LIGHT OIL / Low NOx

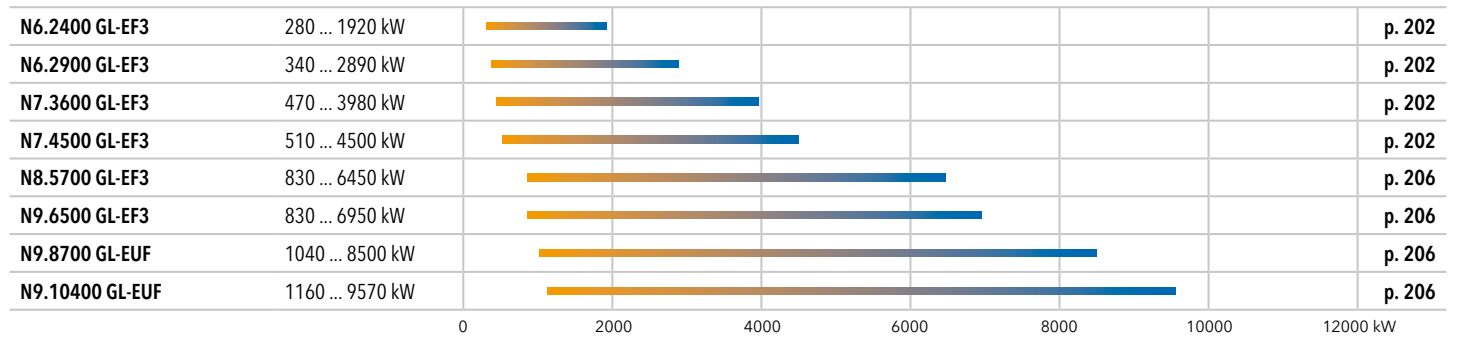

TWO STAGE PROGRESSIVE/MODULATING ELECTRONIC IN GAS AND IN LIGHT OIL

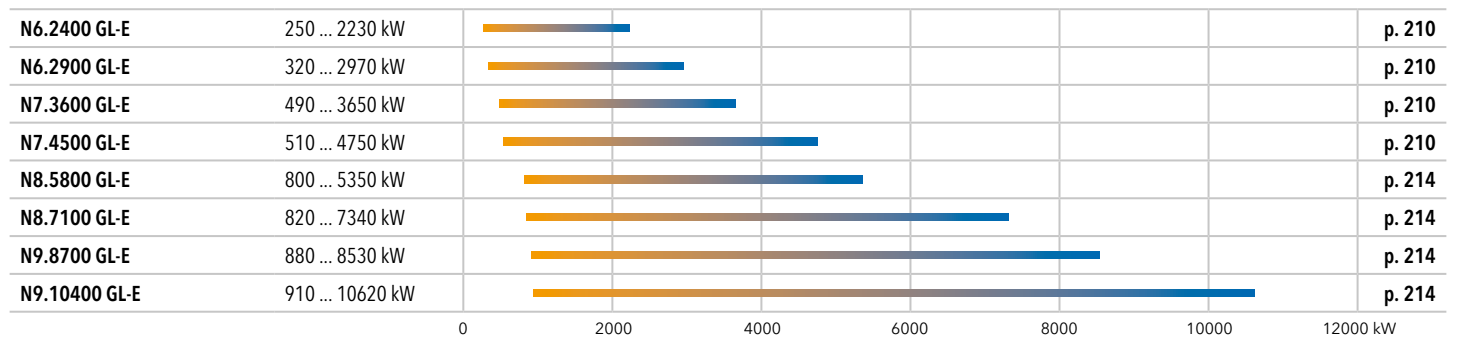

TWO STAGE PROGRESSIVE/MODULATING ELECTRONIC / Low NOx

N6.2400 L-EF3	360 ... 1850 kW		p. 218
N6.2900 L-EF3	480 ... 2950 kW		p. 218
N7.3600 L-EF3	680 ... 4070 kW		p. 218
N7.4500 L-EF3	740 ... 4820 kW		p. 218
N8.5700 L-EF3	1100 ... 6450 kW		p. 220
N9.6500 L-EF3	1200 ... 6600 kW		p. 220
N9.8700 L-EUF	1800 ... 8500 kW		p. 220
N9.10400 L-EUF	2550 ... 9570 kW		p. 220

TWO STAGE PROGRESSIVE/MODULATING ELECTRONIC

N6.2400 L-E	510 ... 2030 kW		p. 222
N6.2900 L-E	650 ... 3100 kW		p. 222
N7.3600 L-E	900 ... 3850 kW		p. 222
N7.4500 L-E	1300 ... 4900 kW		p. 222
N8.5800 L-E	1350 ... 5350 kW		p. 224
N8.7100 L-E	1470 ... 7340 kW		p. 224
N9.8700 L-E	2400 ... 8530 kW		p. 224
N9.10400 L-E	2820 ... 10620 kW		p. 224

BURNER VARIANTS [p. 226](#)BURNER KITS [p. 229](#)SPECIAL CONFIGURATIONS [p. 231](#)

TWO STAGE PROGRESSIVE/MODULATING ELECTRONIC / **ULTRA Low NOx** (FX burner head)

N10.12000 G-EFX	1300 ... 12400 kW		p. 234
N10.14000 G-EFX	1700 ... 14300 kW		p. 234

TWO STAGE PROGRESSIVE/MODULATING ELECTRONIC / **Low NOx**

N10.12000 G-EU2	1500 ... 12300 kW		p. 238
N10.14000 G-EU2	1750 ... 14800 kW		p. 238
N10.16000 G-EU2	2150 ... 16350 kW		p. 238
N11.19000 G-EU2	2750 ... 19000 kW		p. 242
N11.22000 G-EU2	2750 ... 22000 kW		p. 242

TWO STAGE PROGRESSIVE/MODULATING ELECTRONIC

N10.12000 G-E	1300 ... 12000 kW		p. 246
N10.14000 G-E	2000 ... 14000 kW		p. 246
N10.16000 G-E	2000 ... 16000 kW		p. 246

TWO STAGE PROGRESSIVE/MODULATING ELECTRONIC IN GAS AND IN LIGHT OIL / **Low NOx**

N10.12000 GL-EUF	1500 ... 12000 kW		p. 250
N10.14000 GL-EUF	2100 ... 14000 kW		p. 250
N10.16000 GL-EUF	2100 ... 16000 kW		p. 250

TWO STAGE PROGRESSIVE/MODULATING ELECTRONIC IN GAS AND IN LIGHT OIL

N10.12000 GL-E	1300 ... 12000 kW		p. 254
----------------	-------------------	--	--------

TWO STAGE PROGRESSIVE/MODULATING ELECTRONIC / **Low NOx**

N10.12000 L-EUF	3000 ... 12000 kW		p. 258
N10.14000 L-EUF	3150 ... 14000 kW		p. 258
N10.16000 L-EUF	3300 ... 16670 kW		p. 258

TWO STAGE PROGRESSIVE/MODULATING ELECTRONIC

N10.12000 L-E	3600 ... 12000 kW		p. 260
---------------	-------------------	--	--------

ONE STAGE

HO-TRON 0.135	68 ... 136 kW		p. 264
HO-TRON 0.225	108 ... 227 kW		p. 264
HO-TRON 1.350	170 ... 340 kW		p. 266

TWO STAGES

HO-TRON 1.350 Z	205 ... 410 kW		p. 266
HO-TRON 2.580 Z	205 ... 570 kW		p. 266
HO-TRON 2.930 Z	464 ... 930 kW		p. 268
HO-TRON 2.1400 Z	682 ... 1395 kW		p. 268
HO-TRON 3.1700 Z	682 ... 1700 kW		p. 270
HO-TRON 3.2100 Z	682 ... 2093 kW		p. 270
HO-TRON 4.3000 Z	1000 ... 3000 kW		p. 272
HO-TRON 4.3900 Z3	1300 ... 3900 kW		p. 272

TWO STAGE PROGRESSIVE/MODULATING MECHANICAL

HO-TRON 4.3000 R	1000 ... 3000 kW		p. 274
HO-TRON 4.3900 R	1300 ... 3900 kW		p. 274
HO-TRON 5.5000 R	1578 ... 5000 kW		p. 276
HO-TRON 5.5800 R	1795 ... 5800 kW		p. 276
HO-TRON 6.7200 R	2417 ... 7250 kW		p. 278
HO-TRON 6.8500 R	2750 ... 8500 kW		p. 278
HO-TRON 6.10500 R	3300 ... 10500 kW		p. 278
HO-TRON 6.13000 R	4367 ... 12500 kW		p. 278
HO-TRON 7.15000 R	5000 ... 15000 kW		p. 280
HO-TRON 7.17000 R	5700 ... 17000 kW		p. 280

TWO STAGES

GHO-TRON 3.2100 Z	414 ... 2150 kW		p. 284
-------------------	-----------------	--	--------

TWO STAGE PROGRESSIVE/MODULATING MECHANICAL

GHO-TRON 4.3000 R	630 ... 3000 kW		p. 286
GHO-TRON 4.3900 R	875 ... 3900 kW		p. 286
GHO-TRON 5.5000 R	1200 ... 5000 kW		p. 288
GHO-TRON 5.5800 R	1500 ... 5800 kW		p. 288
GHO-TRON 6.7200 R	1500 ... 7500 kW		p. 290
GHO-TRON 6.8500 R	2000 ... 8500 kW		p. 290
GHO-TRON 6.10500 R	2500 ... 10500 kW		p. 290
GHO-TRON 6.13000 R	2700 ... 13000 kW		p. 290
GHO-TRON 7.15000 R	3690 ... 15000 kW		p. 292
GHO-TRON 7.17000 R	4000 ... 17000 kW		p. 292

TWO STAGES and TWO STAGE PROGRESSIVE/MODULATING MECHANICAL or ELECTRONIC p. 296

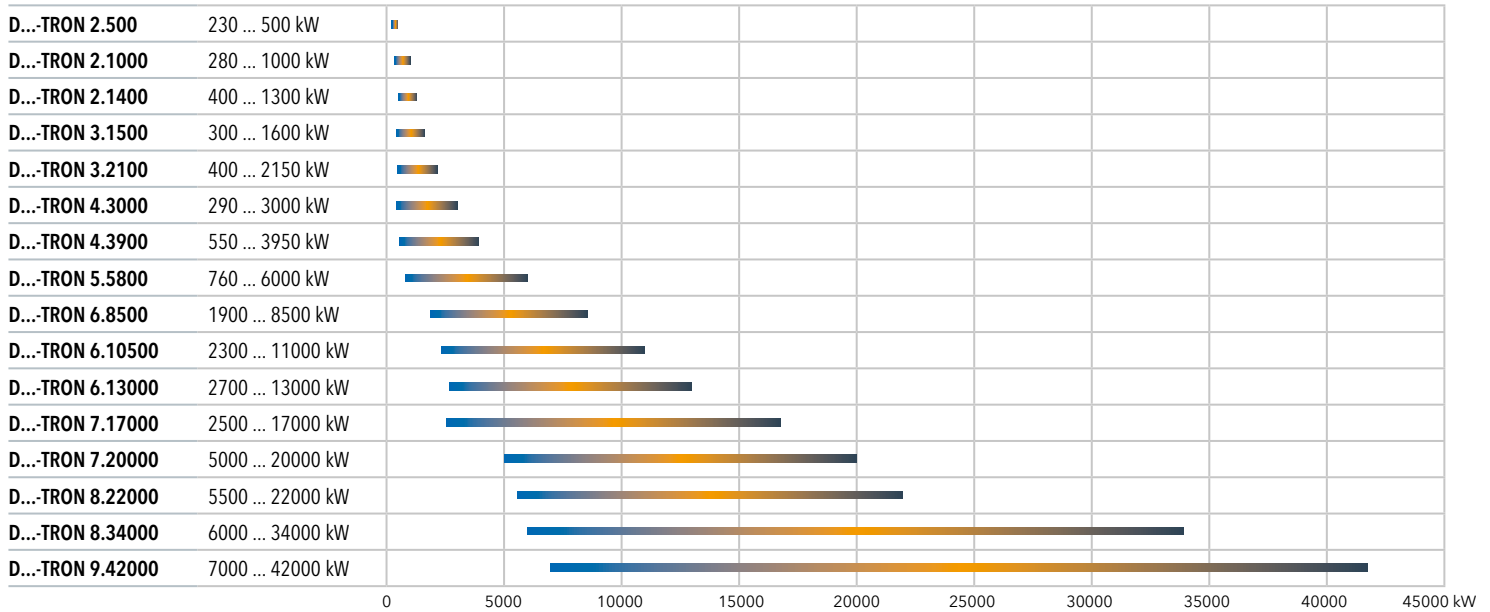

TWO STAGE PROGRESSIVE/MODULATING ELECTRONIC p. 298

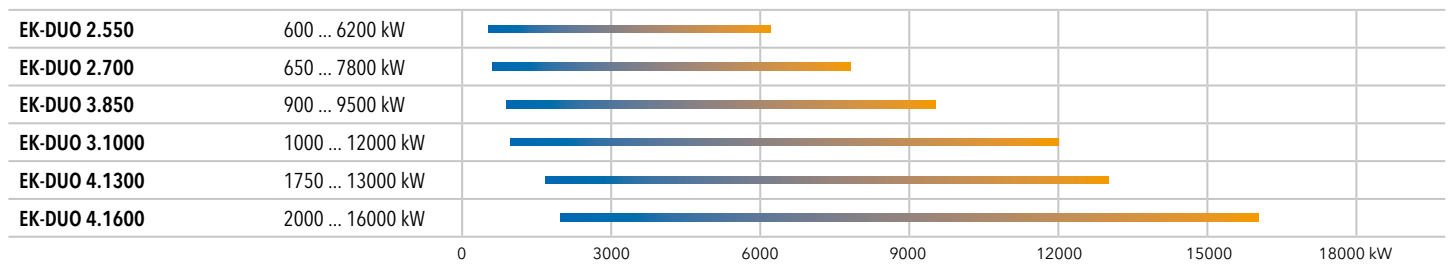

TWO STAGE PROGRESSIVE/MODULATING MECHANICAL AND ELECTRONIC

p. 300

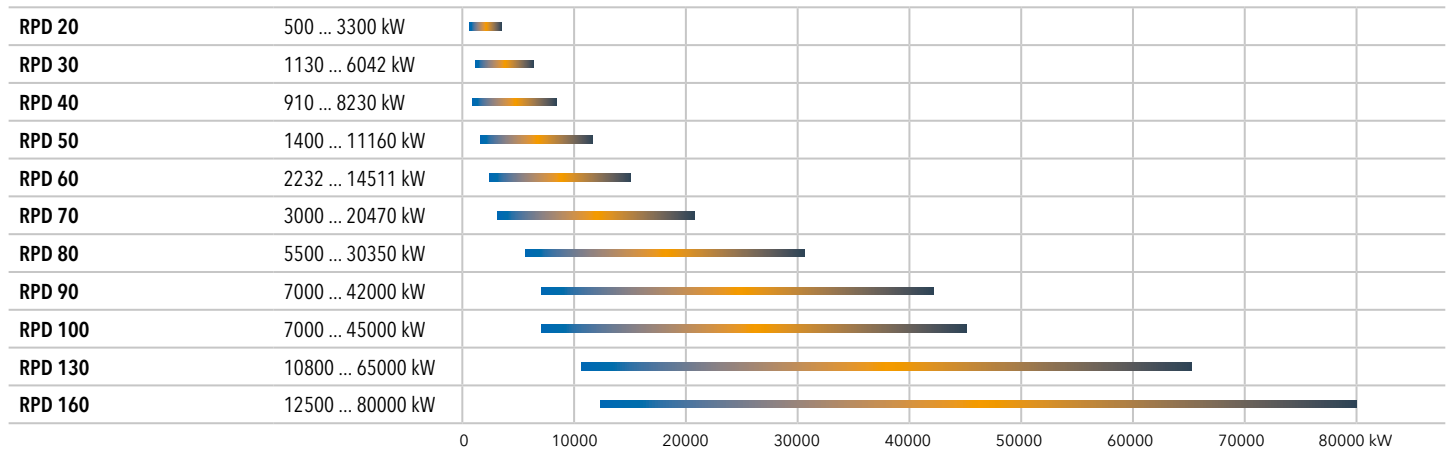

TWO STAGE PROGRESSIVE/MODULATING ELECTRONIC

p. 302

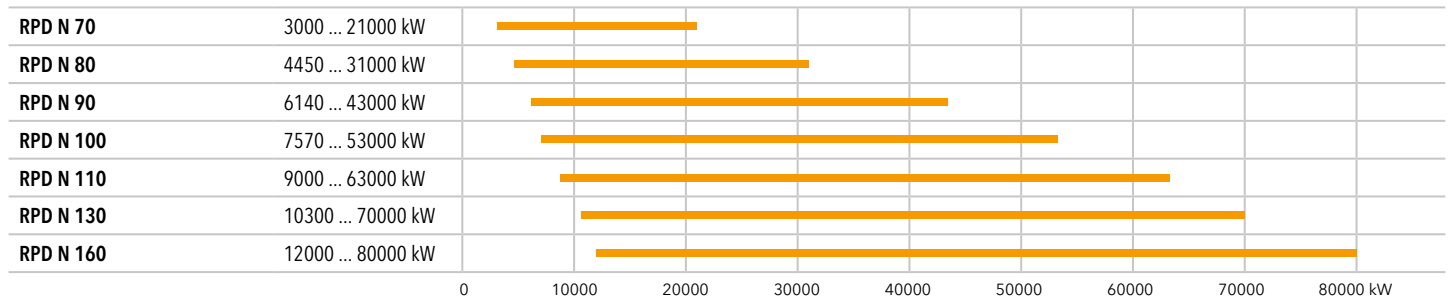

GAS TRAINS

Electronic and mechanical versions for EK-TRON	p. 304
Electronic versions for EK EVO and NEXTRON	p. 308
Electronic versions for N10/N11	p. 312
Mechanical versions for GH0-TRON	p. 314

CONTROL UNITS

BT300	p. 315
ETAMATIC	p. 316

O₂/CO TRIM

O ₂ TRIM for BT300, Etamatic and Etamatic OEM	p. 317
O ₂ TRIM with CO measure for BT300, Etamatic and Etamatic OEM	p. 318

OPTIONS

Frequency converter	p. 320
Acoustic shrouds	p. 321
Options for gas burners	p. 322
Options for light oil burners	p. 328

EK-TRON, EK EVO and NEXTRON range

Burner body

OPERATION TYPE

E = 2 stage progressive/modulating electronic
Z3 = 3 stages (in light oil)

COMBUSTION TYPE

- = Low NOx Class 2
F3, F4, UF = Low NOx, Free Flame technology
U2, U2N, U3 = Low NOx, Diamond Head technology
X2 = Low NOx, Multi-stage technology
FX = Ultra Low NOx, Blue Triple Head technology

EK EVO 6 . 2400 G-EF3 /BT3 /KL /PED

RANGE

EK-TRON 5, 6, 7
 EK EVO 6, 7, 8, 9
 N6, N7, N8, N9

SIZE

Approximate power (kW)

FUEL

G = Natural gas
GL = Dual fuel
L = Light oil

ELECTRICAL EQUIPMENT

/BT3 = BT300

LENGTH

KN = short
KM = medium
KL = long

ADDITIONAL VARIANTS

FGR = FGR equipped
PED = PED equipped
72H = 72-hour continuous operation
FCE = connection arrangement to an external frequency converter
FCO = on-board frequency converter

Combustion head

OPERATION TYPE

E = 2 stage progressive/modulating electronic
R = 2 stage progressive/modulating mechanical
Z3 = 3 stages (in light oil)

COMBUSTION TYPE

- = Low NOx Class 2
F3, F4, UF = Low NOx, Free Flame technology
U2, U2N, U3 = Low NOx, Diamond Head technology
X2 = Low NOx, Multi-stage technology
FX = Ultra Low NOx, Blue Triple Head technology

G11EF31 - KN

FUEL

G = Gas
GL = Dual fuel
L = Light oil

PLATFORM

11 EK EVO 6/N6
12 EK EVO 7/N7
13 EK EVO 8/N8
14 EK EVO 9/N9

SERIES

1 = N°1
2 = N°2
3 = N°3
 ... = N°...

LENGTH

KN = short
KM = medium
KL = long

Gas train

OPERATION TYPE

4 = 2 stage progressive electronic
5 = 2 stage progressive mechanical

SERIES

51 = N°1
 ... = N°...
99 = N°...

d452 - 1"1/2 - Rp 1"1/2

VALVE MANUFACTURER

d = Dungs
s = Siemens

VALVE NOMINAL DIAMETER

1"1/2 ... 2" or DN50 ... DN125

GAS TRAIN CONNECTION DIAMETER

1"1/2 ... 2" or DN50 ... DN125

N range

SIZE

Approximate power (kW)

FUEL

G = Natural gas
GL = Dual fuel
L = Light oil

COMBUSTION TYPE

- = Low NOx Class 2
UF = Low NOx, Free Flame technology
U2 = Low NOx, Diamond Head technology
FX = Low NOx, Blue Triple Head technology

N10 . 14000 G-EU2 /ETO /KN /FGR

RANGE

N10/N11

OPERATION TYPE

E = 2 stage progressive/modulating electronic

ELECTRICAL EQUIPMENT

/ETO = Etamatic OEM

LENGTH

KN = short
KM = medium
KL = long

ADDITIONAL EQUIPMENT

/PED = PED equipped
 /FGR = FGR equipped

HO-TRON and GHO-TRON range

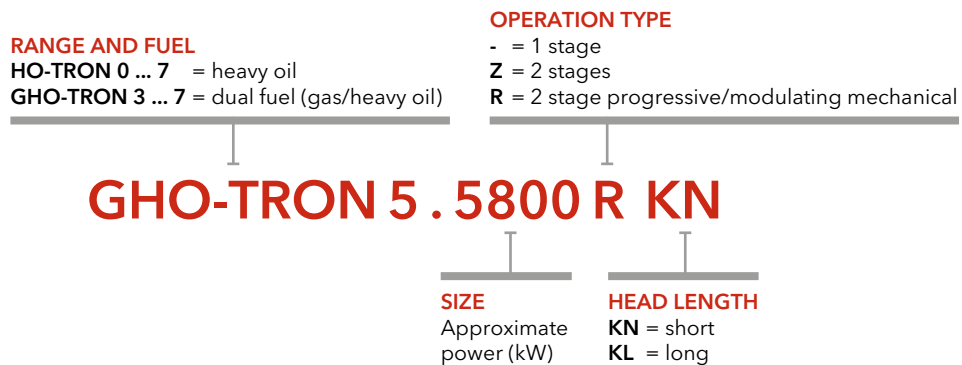

D...-TRON range

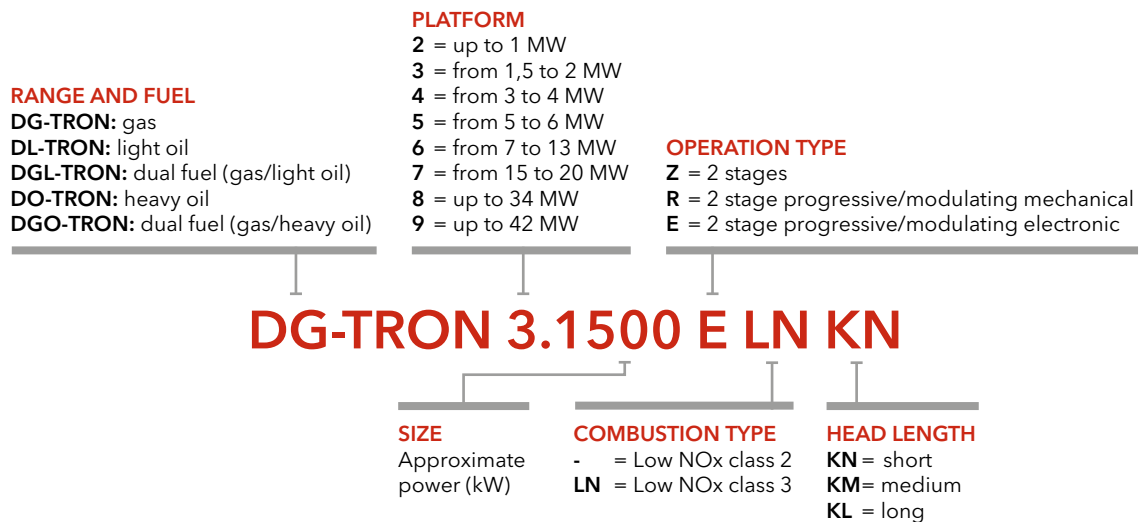

EK-DUO, RPD and RPD N range

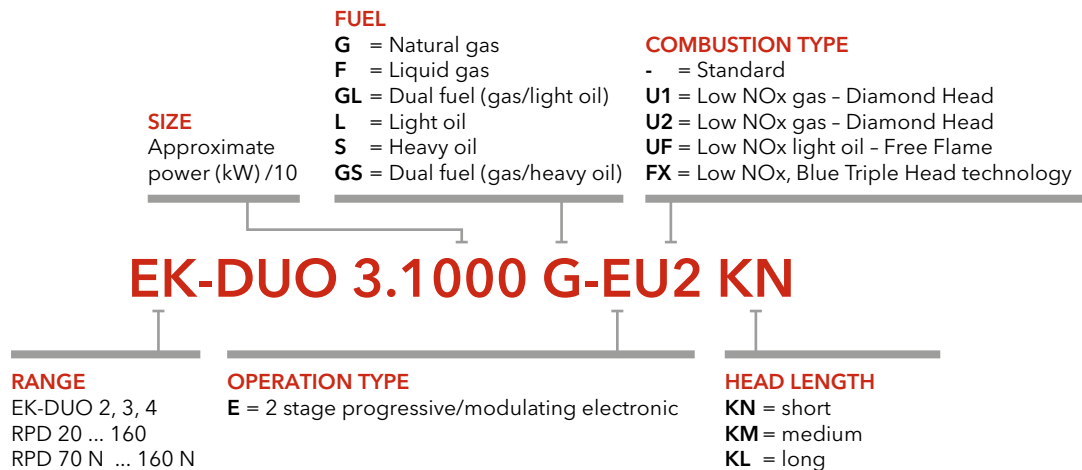

EK-TRON

**MONOBLOCK BURNERS
FROM 320 TO 6050 kW
GAS AND DUAL FUEL**



ROBUST AND RELIABLE DESIGN

The structure of the EK-TRON is the result of a successful synergy between ELCO key features and technologies, developed to meet the needs of any heating application and industrial process.

The essential and simple design of the EK-TRON allows perfect adaptation to any conditions, thanks to the optimal combination of resistant and reliable materials, extreme ease of use and great comfort during daily operation.

FLEXIBILITY AND VERSATILITY

The EK-TRON are characterized by a high flexibility of installation and operation.

They have been designed to be installed in different ways: up-firing, down-firing, upside-down or side-to-side (twin chamber boilers).

Options and configurations have been foreseen in order to fulfill any application need.

CLEAN AND STEADY COMBUSTION

The ELCO combustion technologies are capable to reach the NO_x levels required by the most severe standards for all types of boiler furnaces, even the most narrow ones.

The combination of internal and external recirculation, studied in our laboratories, allows EK-TRON burners to reach extremely low emissions value (between 25 and 28 NO_x mg/kWh at 3% of O₂).

EFFICIENT AND PRACTICAL OPERATIONS

All the models in the series are available with mechanical operation or in a fully electronic configuration.

The electronic versions are equipped with the exclusive ELCO man-machine interface allowing simple and effective programming operations. This results in smooth and performing operation and a quick and simple interaction between the user and the burner.

RANGE OVERVIEW



/ GAS RANGE
340 / 6050 kW

/ DUAL FUEL RANGE
320 / 3900 kW

/ ULTRA LOW NO_x
420 / 5800 kW

MAIN TECHNICAL FEATURES

- Two stage progressive/modulating forced draught burner
- Fuels:
 - natural gas, Hi = 6,99 ... 11,39 kWh/Nm³
 - LPG, Hi = 25,89 kWh/Nm³
 - light oil, viscosity 6 mm²/s at 20°C, Hi = 11,86 kWh/kg
- Fully electronic modulation system or mechanical configuration available for each model
- Different combustion technologies available to reduce NOx emissions without compromising the performance and capable to satisfy even the most difficult conditions in terms of combustion chamber dimension:
 - Low NOx class 2 (<120 mg/kWh) according to EN676 Directive
 - Low NOx class 3 (<80 mg/kWh) according to EN676 Directive
 - Ultra Low NOx versions with FGR system to reach NOx values well below 30 mg/kWh are available on request
- Simplified switch cabinet to meet the majority of the application requirements
- Redesigned ventilation system for a more compact structure
- Easily adjustable combustion head to adapt to different boiler specifications and emission level requirements
- Flame tube available in different lengths
- Secured burner head adjustments during maintenance (RTC System)
- Closing of the air damper on burner shut-down
- Multiple gas train matching according to the inlet gas pressure
- Gas train factory assembled and tested for tightness and electrical security
- Products are in compliance with EN676 and EN267 European standards and with the following directives:
 - 2014/35/UE Low Voltage Directive
 - 2014/30/UE EMC Directive
 - 2016/426/UE Gas Appliances Regulation
 - 2006/42/EC Machinery Directive
 - 2011/65/EU RoHS2 Directive

PRODUCT LIST

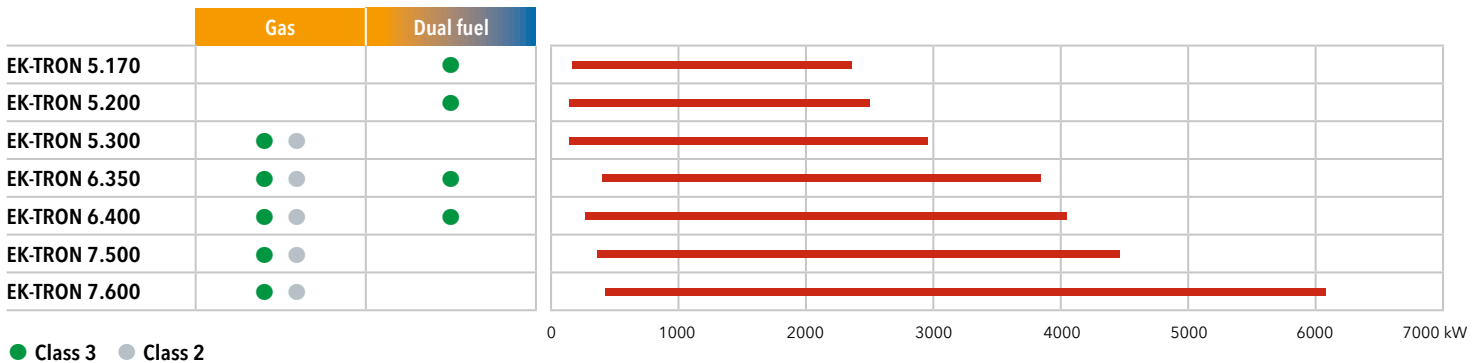

EMISSIONS

EK-TRON burners are equipped with combustion technologies that allow these models not only to meet the NOx limit imposed by the EN676 Standard, but also to work well below the requirements, ensuring extremely low emissions:

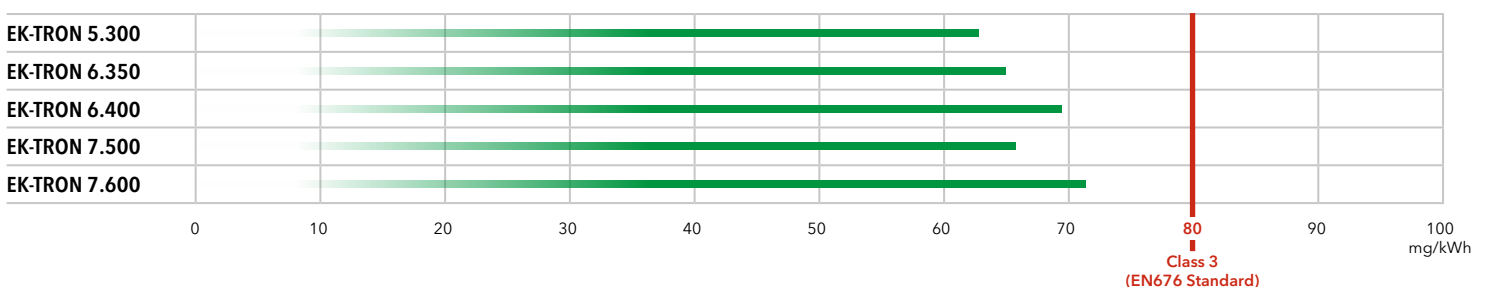

EK-TRON 5 G-EF3 / EK-TRON 6 G-EF3 / EK-TRON 7 G-EF3

400 ... 5800 kW

Two stage progressive/modulating electronic



- **Fuel:** natural gas, Hi = 6,99 ... 11,39 kWh/Nm³
- **Emissions:** Low NOx class 3 burners (≤80 mg/kWh) according to EN676 Directive equipped with Low NOx Free Flame combustion head
- **Additional configuration:** models with FGR System (≤30 mg/kWh) available on request
- **Protection level:** IP 40

TECHNICAL DATA

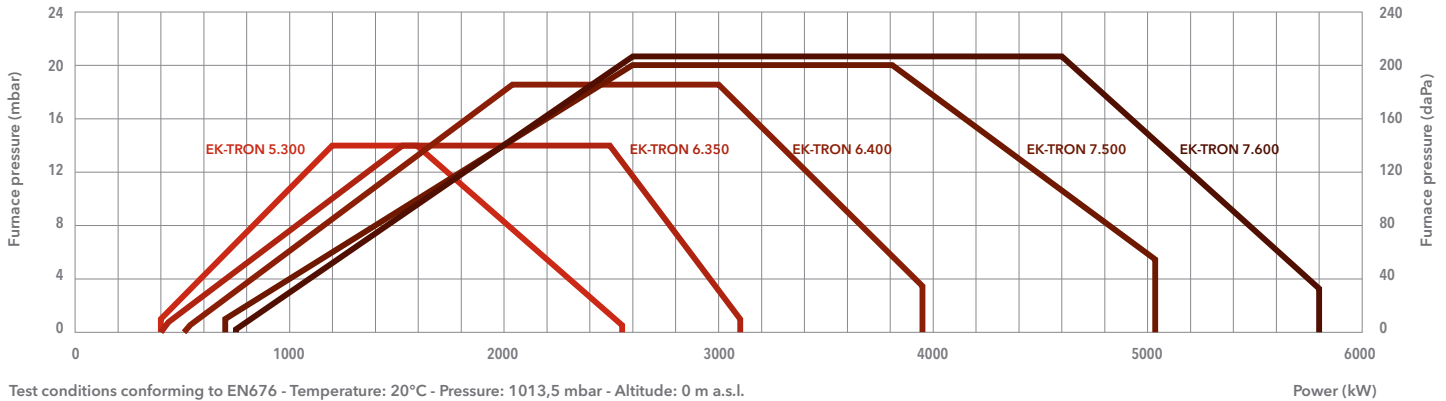

Test conditions conforming to EN676 - Temperature: 20°C - Pressure: 1013,5 mbar - Altitude: 0 m a.s.l.

	EK-TRON 5.300 G-EF3	EK-TRON 6.350 G-EF3	EK-TRON 6.400 G-EF3	EK-TRON 7.500 G-EF3	EK-TRON 7.600 G-EF3
Operating range	400 – 2550 kW	400 – 3100 kW	510 – 3950 kW	700 – 5030 kW	750 – 5800 kW
Gas connection	DN50	DN50	DN65	DN65	DN65
Control box / flame detector	BT320 / QRA2*	BT320 / QRA2*	BT320 / QRA2*	BT320 / QRA2*	BT320 / QRA2*
Auxiliary voltage	1NPE AC 230 V - 50 Hz TN-S	1NPE AC 230 V - 50 Hz TN-S	1NPE AC 230 V - 50 Hz TN-S	1NPE AC 230 V - 50 Hz TN-S	1NPE AC 230 V - 50 Hz TN-S
Power supply	3NPE AC 400 V - 50 Hz	3NPE AC 400 V - 50 Hz	3NPE AC 400 V - 50 Hz	3NPE AC 400 V - 50 Hz	3NPE AC 400 V - 50 Hz
Fan motor	4 kW	5,5 kW	7,5 kW	11 kW	15 kW
Acoustic level	<83 dB(A)	<84 dB(A)	<85 dB(A)	<85 dB(A)	<85 dB(A)
Burner codes (body + head)	KM 3148195	KM 3148425	KM 3148197	KM 3148199	KM 3148201
	KL 3148196	KL 3148426	KL 3148198	KL 3148200	KL 3148202

*: BT330 / FFS08 for 72H versions

OTHER AVAILABLE VERSIONS

Variant		EK-TRON 5.300 G-EF3	EK-TRON 6.350 G-EF3	EK-TRON 6.400 G-EF3	EK-TRON 7.500 G-EF3	EK-TRON 7.600 G-EF3
72H	KM	3148450	3148452	3148454	3148456	3148458
	KL	3148451	3148453	3148455	3148457	3148459
FCE	KM	3148474	3148476	3148478	3148480	3148482
	KL	3148475	3148477	3148479	3148481	3148483
72H + FCE	KM	3148486	3148488	3148490	3148492	3148494
	KL	3148487	3148489	3148491	3148493	3148495
FCO	KM	3148920	3148922	3148924	3148926	3148928
	KL	3148921	3148923	3148925	3148927	3148929
72H + FCO	KM	3148930	3148932	3148934	3148936	3148938
	KL	3148931	3148933	3148935	3148937	3148939

GAS TRAINS AND FILTERS

DUNGS models	Code
GT-D1-MBEVB-RP50-PS2	3148693
GT-D1-MBEVB-DN65-PS2	3148694
GT-D1-MBEVB-DN80-PS2	3148695
GT-D1-MBEVB-DN100-PS2	3148696

SIEMENS models	Code
GT-S1-VGD20-RP50-PS2	3148683
GT-S1-VGD40-DN65-PS2	3148684
GT-S1-VGD40-DN80-PS2	3148685
GT-S1-VGD40-DN100-PS2	3148686
GT-S1-VGD40-DN125-PS2	3148687

Filters	Code
FG-Rp2"	3757200
FG-DN65	3757198
FG-DN80	3757201
FG-DN100	3757195
FG-DN125	3757209



DIMENSIONS (mm)

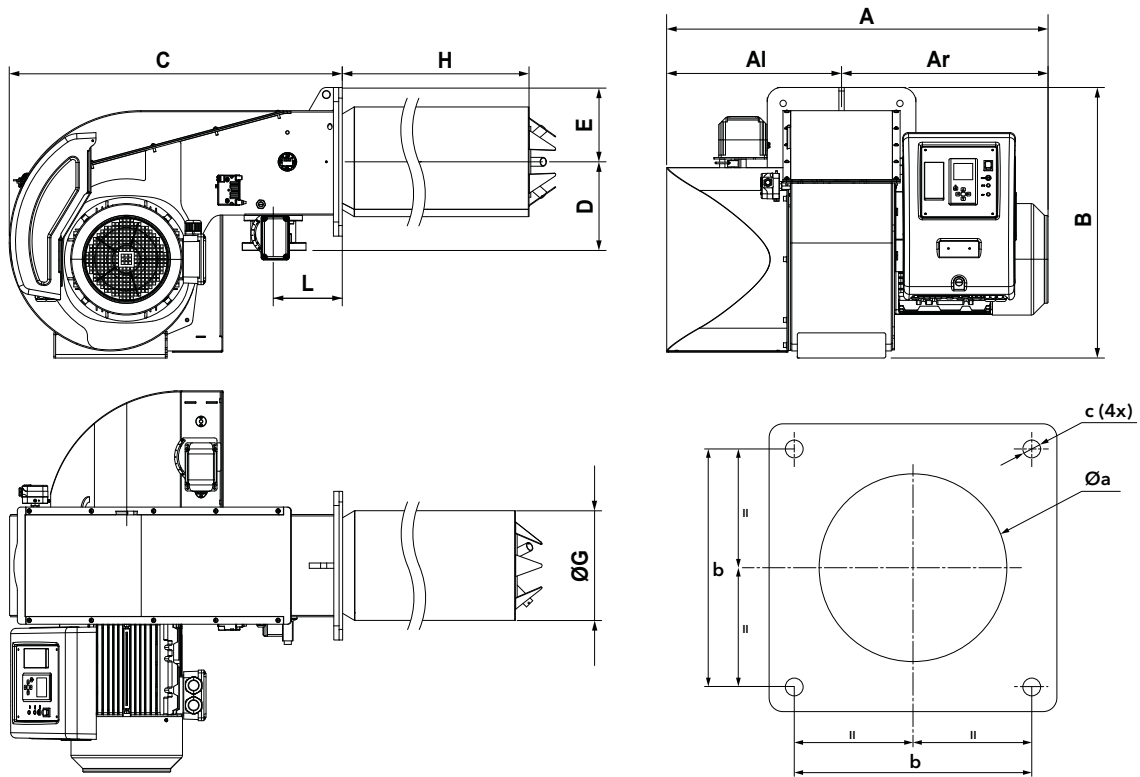

Model	A	AI	Ar	B	C	D	E	ØG	H		L	Øa	b	c
									KM	KL				
EK-TRON 5.300 G-EF3	813	356	457	606	724	245	190	263	540	640	125	278-288	315	M16
EK-TRON 6.350 G-EF3	875	387	488	684	828	250	190	263	550	650	195	278-288	315	M16
EK-TRON 6.400 G-EF3	875	387	488	684	828	250	190	310	548	638	195	325-335	315	M16
EK-TRON 7.500 G-EF3	1083	494	589	780	943	250	210	310	558	688	195	325-335	330	M16
EK-TRON 7.600 G-EF3	1083	494	589	780	943	250	210	323	558	688	195	338-348	330	M16

Note: dimensions may vary depending on the configuration chosen

PACKAGING

The burner is delivered on a pallet with:

- burner body and combustion head (to be mounted by the installer)
- gas train and filter
- boiler fixing accessories
- technical documentation

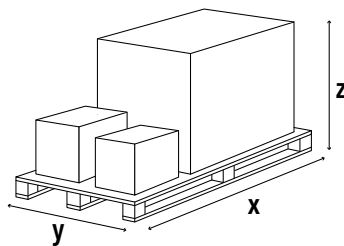

Model	Dimensions (mm)		
	X	Y	Z
EK-TRON 5.300 G-EF3	1100	900	720
EK-TRON 6.350 G-EF3	1100	900	720
EK-TRON 6.400 G-EF3	1100	900	720
EK-TRON 7.500 G-EF3	1300	1050	900
EK-TRON 7.600 G-EF3	1300	1050	900

EK-TRON 5 G-EF3 / EK-TRON 6 G-EF3 / EK-TRON 7 G-EF3

400 ... 5800 kW

Two stage progressive/modulating electronic

PRESSURE LOSS [BURNER HEAD + GAS TRAIN] (mbar)

EK-TRON 5.300 G-EF3

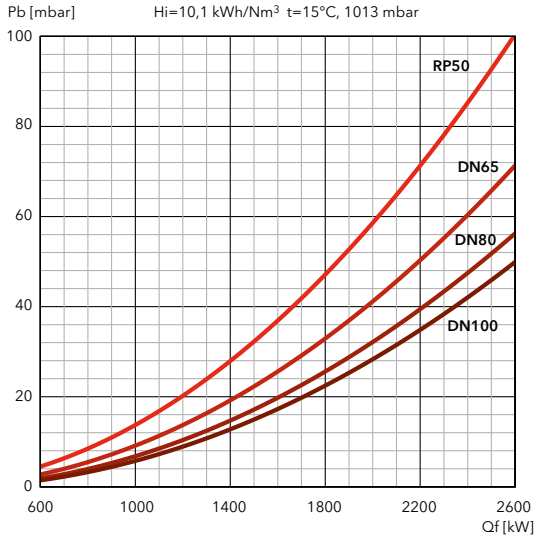

i Each gas train must be installed with its own **connection pipe**, to be selected from the following table:

Gas train model	Code	Connection pipe
GT-S1-VGD20-RP50-PS2	3148683	3144686
GT-S1-VGD40-DN65-PS2	3148684	3148771
GT-S1-VGD40-DN80-PS2	3148685	3148772
GT-S1-VGD40-DN100-PS2	3148686	3148773
GT-D1-MBEVB-RP50-PS2	3148693	3144686
GT-D1-MBEVB-DN65-PS2	3148694	3148771
GT-D1-MBEVB-DN80-PS2	3148695	3148772
GT-D1-MBEVB-DN100-PS2	3148696	3148773

Dimensions of gas trains and connection pipes: see page 304

EK-TRON 6.350 G-EF3

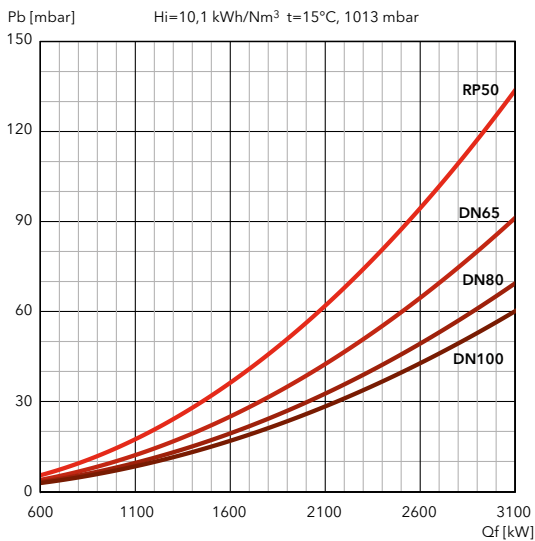

i Each gas train must be installed with its own **connection pipe**, to be selected from the following table:

Gas train model	Code	Connection pipe
GT-S1-VGD20-RP50-PS2	3148683	3144686
GT-S1-VGD40-DN65-PS2	3148684	3148771
GT-S1-VGD40-DN80-PS2	3148685	3148772
GT-S1-VGD40-DN100-PS2	3148686	3148773
GT-D1-MBEVB-RP50-PS2	3148693	3144686
GT-D1-MBEVB-DN65-PS2	3148694	3148771
GT-D1-MBEVB-DN80-PS2	3148695	3148772
GT-D1-MBEVB-DN100-PS2	3148696	3148773

Dimensions of gas trains and connection pipes: see page 304

EK-TRON 6.400 G-EF3

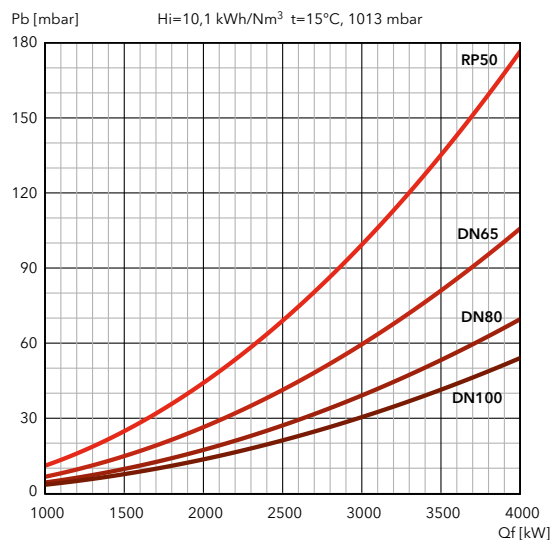

i Each gas train must be installed with its own **connection pipe**, to be selected from the following table:

Gas train model	Code	Connection pipe
GT-S1-VGD20-RP50-PS2	3148683	3148770
GT-S1-VGD40-DN65-PS2	3148684	3145997
GT-S1-VGD40-DN80-PS2	3148685	3145864
GT-S1-VGD40-DN100-PS2	3148686	3145821
GT-D1-MBEVB-RP50-PS2	3148693	3148770
GT-D1-MBEVB-DN65-PS2	3148694	3145997
GT-D1-MBEVB-DN80-PS2	3148695	3145864
GT-D1-MBEVB-DN100-PS2	3148696	3145821

Dimensions of gas trains and connection pipes: see page 304



PRESSURE LOSS [BURNER HEAD + GAS TRAIN] (mbar)

EK-TRON 7.500 G-EF3

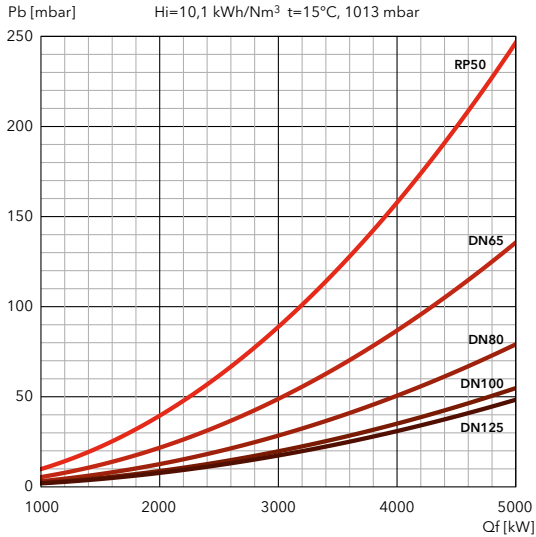

i Each gas train must be installed with its own **connection pipe**, to be selected from the following table:

Gas train model	Code	Connection pipe
GT-S1-VGD20-RP50-PS2	3148683	3148770
GT-S1-VGD40-DN65-PS2	3148684	3148766
GT-S1-VGD40-DN80-PS2	3148685	3148767
GT-S1-VGD40-DN100-PS2	3148686	3148768
GT-S1-VGD40-DN125-PS2	3148687	3148769
GT-D1-MBEVB-RP50-PS2	3148693	3148770
GT-D1-MBEVB-DN65-PS2	3148694	3148766
GT-D1-MBEVB-DN80-PS2	3148695	3148767
GT-D1-MBEVB-DN100-PS2	3148696	3148768

Dimensions of gas trains and connection pipes: see page 304

EK-TRON 7.600 G-EF3

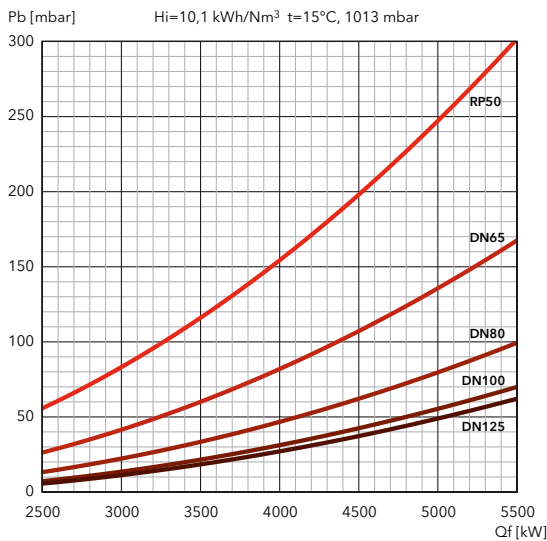

i Each gas train must be installed with its own **connection pipe**, to be selected from the following table:

Gas train model	Code	Connection pipe
GT-S1-VGD20-RP50-PS2	3148683	3148770
GT-S1-VGD40-DN65-PS2	3148684	3148766
GT-S1-VGD40-DN80-PS2	3148685	3148767
GT-S1-VGD40-DN100-PS2	3148686	3148768
GT-S1-VGD40-DN125-PS2	3148687	3148769
GT-D1-MBEVB-RP50-PS2	3148693	3148770
GT-D1-MBEVB-DN65-PS2	3148694	3148766
GT-D1-MBEVB-DN80-PS2	3148695	3148767
GT-D1-MBEVB-DN100-PS2	3148696	3148768

Dimensions of gas trains and connection pipes: see page 304

FILTERS

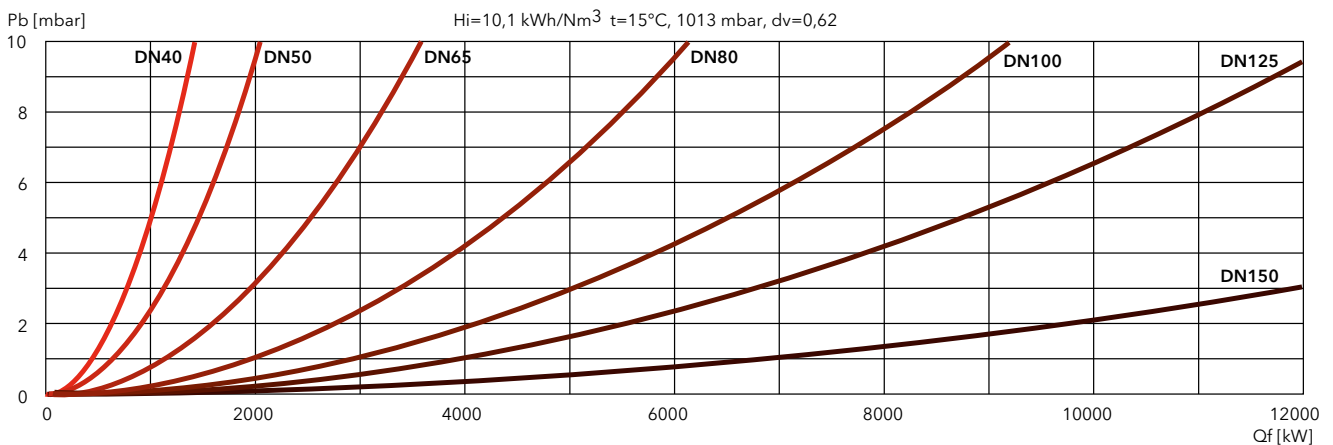

EK-TRON 5 G-RF3 / EK-TRON 6 G-RF3 / EK-TRON 7 G-RF3

400 ... 5800 kW

Two stage progressive/modulating mechanical



- **Fuel:** natural gas, Hi = 6,99 ... 11,39 kWh/Nm³
- **Emissions:** Low NOx class 3 burners (≤80 mg/kWh) according to EN676 Directive equipped with Low NOx Free Flame combustion head
- **Protection level:** IP 40

TECHNICAL DATA

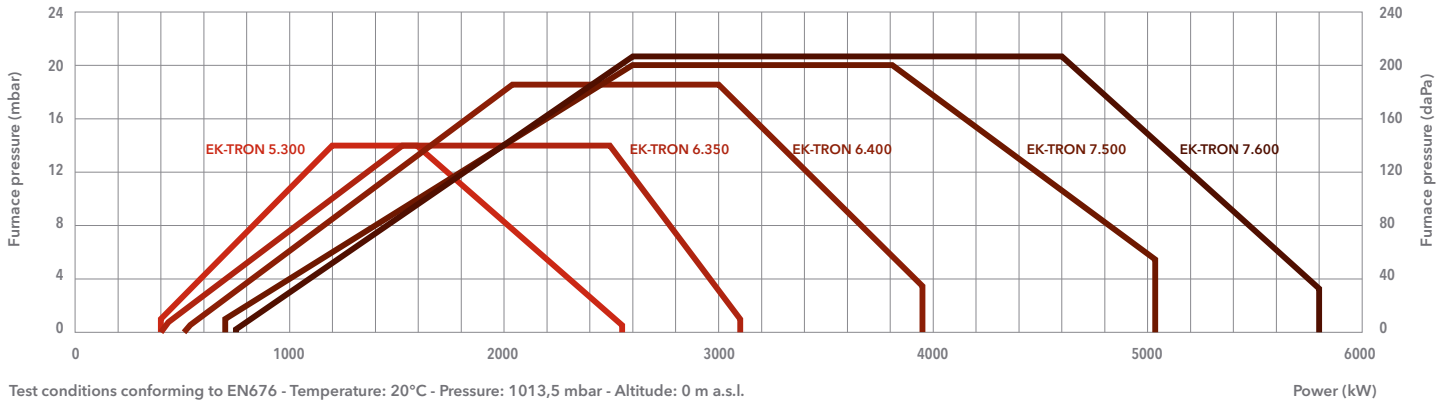

Test conditions conforming to EN676 - Temperature: 20°C - Pressure: 1013,5 mbar - Altitude: 0 m a.s.l.

	EK-TRON 5.300 G-RF3	EK-TRON 6.350 G-RF3	EK-TRON 6.400 G-RF3	EK-TRON 7.500 G-RF3	EK-TRON 7.600 G-RF3
Operating range	400 – 2550 kW	400 – 3100 kW	510 – 3950 kW	700 – 5030 kW	750 – 5800 kW
Gas connection	DN50	DN50	DN65	DN65	DN65
Control box / flame detector	LME73 / QRA2*	LME73 / QRA2*	LME73 / QRA2*	LME73 / QRA2*	LME73 / QRA2*
Auxiliary voltage	1NPE AC 230 V - 50 Hz TN-S	1NPE AC 230 V - 50 Hz TN-S	1NPE AC 230 V - 50 Hz TN-S	1NPE AC 230 V - 50 Hz TN-S	1NPE AC 230 V - 50 Hz TN-S
Power supply	3NPE AC 400 V - 50 Hz	3NPE AC 400 V - 50 Hz	3NPE AC 400 V - 50 Hz	3NPE AC 400 V - 50 Hz	3NPE AC 400 V - 50 Hz
Fan motor	4 kW	5,5 kW	7,5 kW	11 kW	15 kW
Acoustic level	<83 dB(A)	<84 dB(A)	<85 dB(A)	<85 dB(A)	<85 dB(A)
Burner codes (body + head)	KM 3148297	KM 3148427	KM 3148299	KM 3148301	KM 3148303
	KL 3148298	KL 3148428	KL 3148300	KL 3148302	KL 3148304

*: LME75 / QRA73 for 72H versions

OTHER AVAILABLE VERSIONS

Variant		EK-TRON 5.300 G-RF3	EK-TRON 6.350 G-RF3	EK-TRON 6.400 G-RF3	EK-TRON 7.500 G-RF3	EK-TRON 7.600 G-RF3
72H	KM	3148462	3148464	3148466	3148468	3148470
	KL	3148463	3148465	3148467	3148469	3148471

GAS TRAINS AND FILTERS

DUNGS models	Code
GT-D1-MBEVB-RP50-PS3	3148697
GT-D1-MBEVB-DN65-PS3	3148698
GT-D1-MBEVB-DN80-PS3	3148699
GT-D1-MBEVB-DN100-PS3	3148700

SIEMENS models	Code
GT-S1-VGD20-RP50-PS3	3148688
GT-S1-VGD40-DN65-PS3	3148689
GT-S1-VGD40-DN80-PS3	3148690
GT-S1-VGD40-DN100-PS3	3148691
GT-S1-VGD40-DN125-PS3	3148692

Filters	Code
FG-Rp2"	3757200
FG-DN65	3757198
FG-DN80	3757201
FG-DN100	3757195
FG-DN125	3757209

DIMENSIONS (mm)

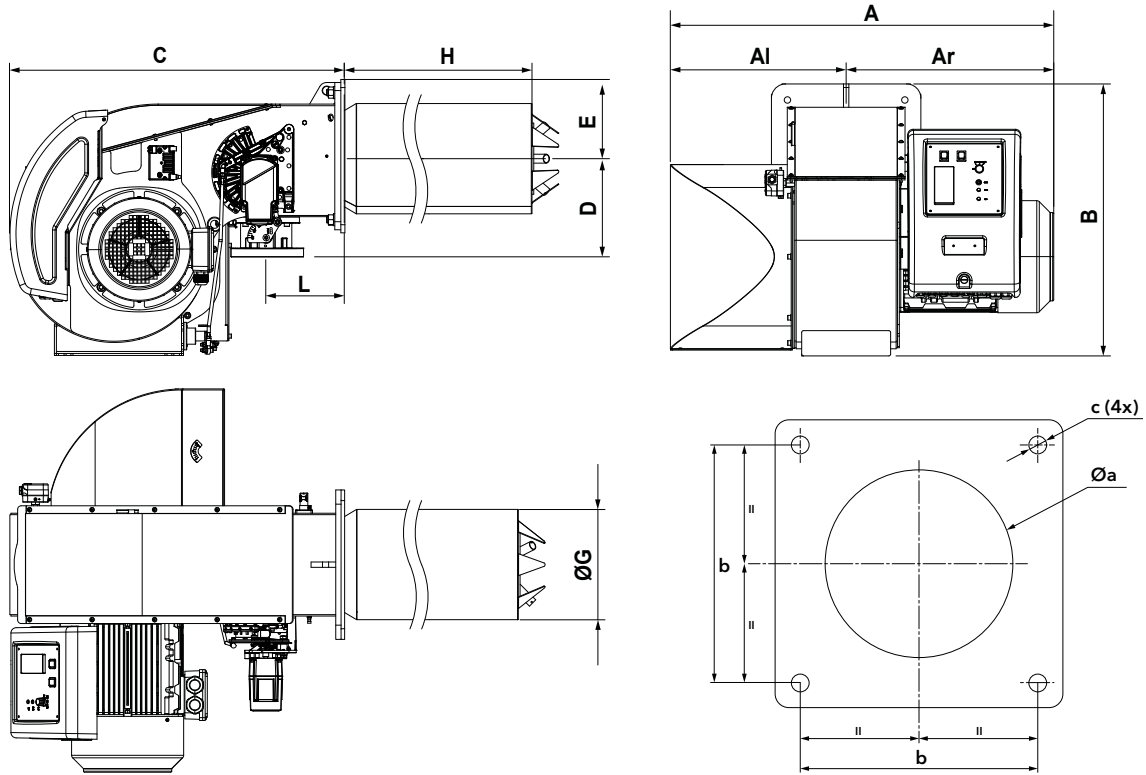

Model	A	Al	Ar	B	C	D	E	ØG	H		L	Øa	b	c
									KM	KL				
EK-TRON 5.300 G-RF3	813	356	457	606	724	245	190	263	540	640	125	278-288	315	M16
EK-TRON 6.350 G-RF3	875	387	488	684	828	250	190	263	550	650	195	278-288	315	M16
EK-TRON 6.400 G-RF3	875	387	488	684	828	250	190	310	548	638	195	325-335	315	M16
EK-TRON 7.500 G-RF3	1083	494	589	780	943	250	210	310	558	688	195	325-335	330	M16
EK-TRON 7.600 G-RF3	1083	494	589	780	943	250	210	323	558	688	195	338-348	330	M16

PACKAGING

The burner is delivered on a pallet with:

- burner body and combustion head (to be mounted by the installer)
- gas train and filter
- boiler fixing accessories
- technical documentation

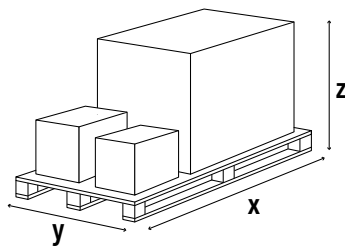

Model	Dimensions (mm)		
	X	Y	Z
EK-TRON 5.300 G-RF3	1100	900	720
EK-TRON 6.350 G-RF3	1100	900	720
EK-TRON 6.400 G-RF3	1100	900	720
EK-TRON 7.500 G-RF3	1300	1050	900
EK-TRON 7.600 G-RF3	1300	1050	900

EK-TRON 5 G-RF3 / EK-TRON 6 G-RF3 / EK-TRON 7 G-RF3

400 ... 5800 kW

Two stage progressive/modulating mechanical

PRESSURE LOSS [BURNER HEAD + GAS TRAIN] (mbar)

EK-TRON 5.300 G-RF3

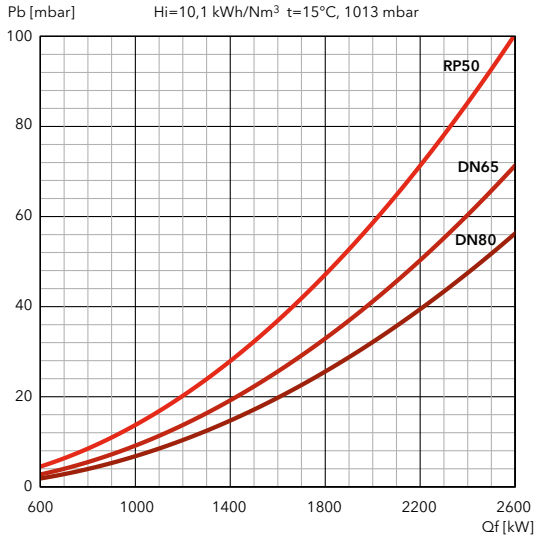

i Each gas train must be installed with its own **connection pipe**, to be selected from the following table:

Gas train model	Code	Connection pipe
GT-S1-VGD20-RP50-PS3	3148688	3144686
GT-S1-VGD40-DN65-PS3	3148689	3148771
GT-S1-VGD40-DN80-PS3	3148690	3148772
GT-D1-MBEVB-RP50-PS3	3148697	3144686
GT-D1-MBEVB-DN65-PS3	3148698	3148771
GT-D1-MBEVB-DN80-PS3	3148699	3148772

Dimensions of gas trains and connection pipes: see page 304

EK-TRON 6.350 G-RF3

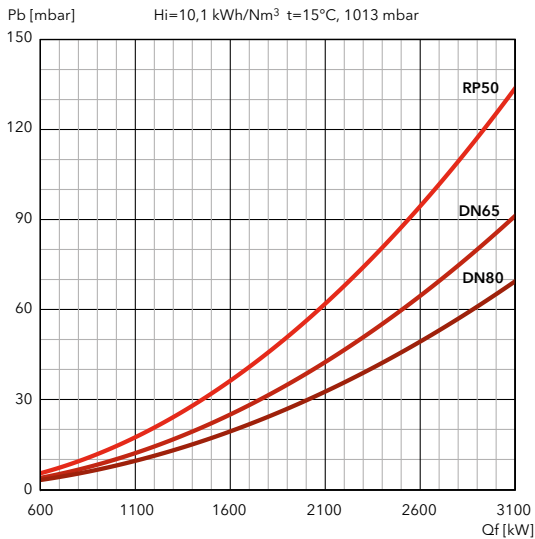

i Each gas train must be installed with its own **connection pipe**, to be selected from the following table:

Gas train model	Code	Connection pipe
GT-S1-VGD20-RP50-PS3	3148688	3144686
GT-S1-VGD40-DN65-PS3	3148689	3148771
GT-S1-VGD40-DN80-PS3	3148690	3148772
GT-D1-MBEVB-RP50-PS3	3148697	3144686
GT-D1-MBEVB-DN65-PS3	3148698	3148771
GT-D1-MBEVB-DN80-PS3	3148699	3148772

Dimensions of gas trains and connection pipes: see page 304

EK-TRON 6.400 G-RF3

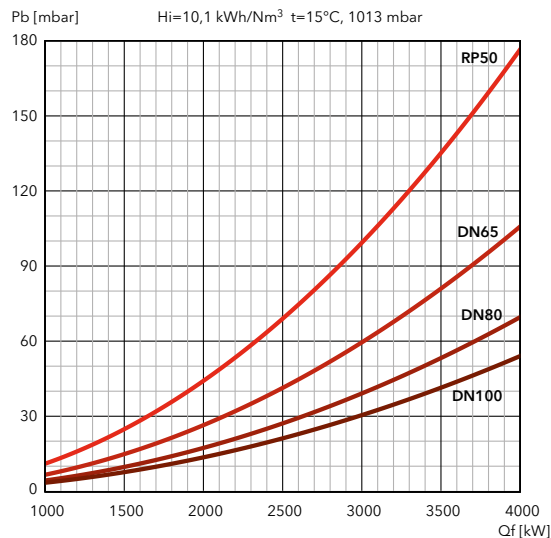

i Each gas train must be installed with its own **connection pipe**, to be selected from the following table:

Gas train model	Code	Connection pipe
GT-S1-VGD20-RP50-PS3	3148688	3148770
GT-S1-VGD40-DN65-PS3	3148689	3145997
GT-S1-VGD40-DN80-PS3	3148690	3145864
GT-S1-VGD40-DN100-PS3	3148691	3145821
GT-D1-MBEVB-RP50-PS3	3148697	3148770
GT-D1-MBEVB-DN65-PS3	3148698	3145997
GT-D1-MBEVB-DN80-PS3	3148699	3145864
GT-D1-MBEVB-DN100-PS3	3148700	3145821

Dimensions of gas trains and connection pipes: see page 304

PRESSURE LOSS [BURNER HEAD + GAS TRAIN] (mbar)

EK-TRON 7.500 G-RF3

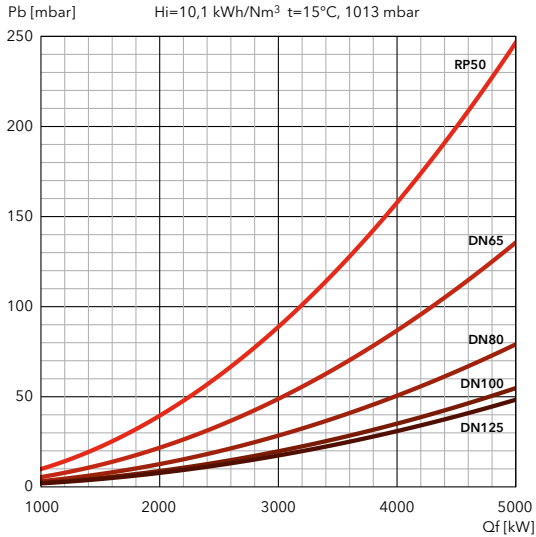

i Each gas train must be installed with its own **connection pipe**, to be selected from the following table:

Gas train model	Code	Connection pipe
GT-S1-VGD20-RP50-PS3	3148688	3148770
GT-S1-VGD40-DN65-PS3	3148689	3148766
GT-S1-VGD40-DN80-PS3	3148690	3148767
GT-S1-VGD40-DN100-PS3	3148691	3148768
GT-S1-VGD40-DN125-PS3	3148692	3148769
GT-D1-MBEVB-RP50-PS3	3148697	3148770
GT-D1-MBEVB-DN65-PS3	3148698	3148766
GT-D1-MBEVB-DN80-PS3	3148699	3148767
GT-D1-MBEVB-DN100-PS3	3148700	3148768

Dimensions of gas trains and connection pipes: see page 304

EK-TRON 7.600 G-RF3

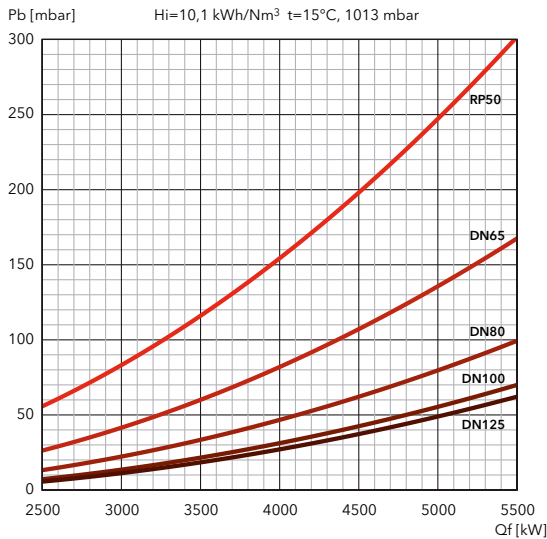

i Each gas train must be installed with its own **connection pipe**, to be selected from the following table:

Gas train model	Code	Connection pipe
GT-S1-VGD20-RP50-PS3	3148688	3148770
GT-S1-VGD40-DN65-PS3	3148689	3148766
GT-S1-VGD40-DN80-PS3	3148690	3148767
GT-S1-VGD40-DN100-PS3	3148691	3148768
GT-S1-VGD40-DN125-PS3	3148692	3148769
GT-D1-MBEVB-RP50-PS3	3148697	3148770
GT-D1-MBEVB-DN65-PS3	3148698	3148766
GT-D1-MBEVB-DN80-PS3	3148699	3148767
GT-D1-MBEVB-DN100-PS3	3148700	3148768

Dimensions of gas trains and connection pipes: see page 304

FILTERS

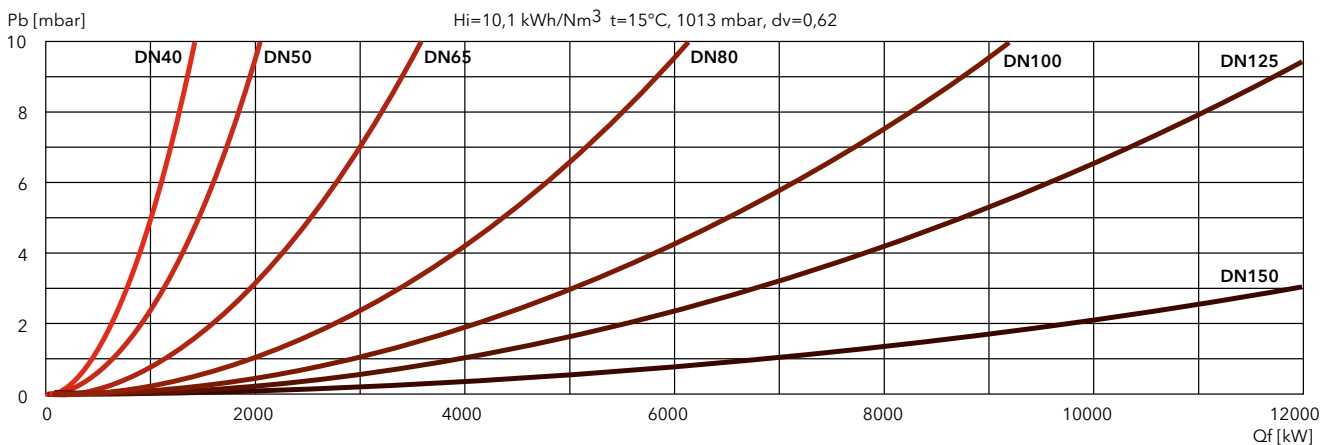

EK-TRON 5 G-E / EK-TRON 6 G-E / EK-TRON 7 G-E

340 ... 6050 kW

Two stage progressive/modulating electronic



- **Fuel:** natural gas, Hi = 6,99 ... 11,39 kWh/Nm³
- **Emissions:** Low NOx class 2 burners (≤120 mg/kWh) according to EN676 Directive
- **Protection level:** IP 40

TECHNICAL DATA

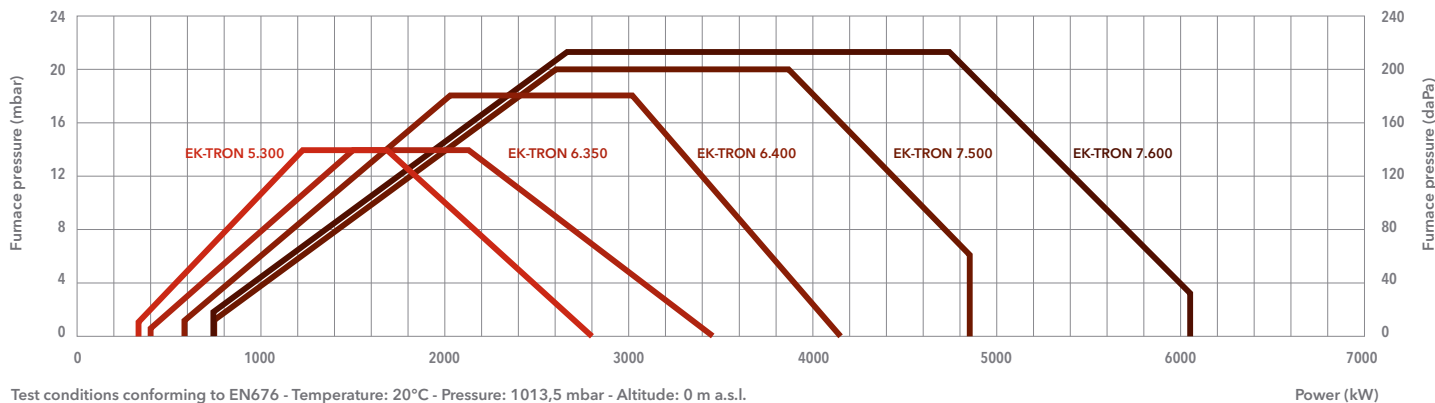

Test conditions conforming to EN676 - Temperature: 20°C - Pressure: 1013,5 mbar - Altitude: 0 m a.s.l.

	EK-TRON 5.300 G-E	EK-TRON 6.350 G-E	EK-TRON 6.400 G-E	EK-TRON 7.500 G-E	EK-TRON 7.600 G-E
Operating range	340 - 2800 kW	400 - 3450 kW	590 - 4150 kW	750 - 4850 kW	740 - 6050 kW
Gas connection	DN50	DN50	DN65	DN65	DN65
Control box / flame detector	BT320* / ionization	BT320* / ionization	BT320* / ionization	BT320* / ionization	BT320* / ionization
Auxiliary voltage	1NPE AC 230 V - 50 Hz TN-S	1NPE AC 230 V - 50 Hz TN-S	1NPE AC 230 V - 50 Hz TN-S	1NPE AC 230 V - 50 Hz TN-S	1NPE AC 230 V - 50 Hz TN-S
Power supply	3NPE AC 400 V - 50 Hz	3NPE AC 400 V - 50 Hz	3NPE AC 400 V - 50 Hz	3NPE AC 400 V - 50 Hz	3NPE AC 400 V - 50 Hz
Fan motor	4 kW	5,5 kW	7,5 kW	11 kW	15 kW
Acoustic level	<83 dB(A)	<84 dB(A)	<85 dB(A)	<85 dB(A)	<85 dB(A)
Burner codes (body + head)	KN	3148784	3148785	3148786	3148787
	KM	3148325	3148327	3148329	3148331
	KL	3148326	3148328	3148330	3148332

*: BT330 for 72H versions

OTHER AVAILABLE VERSIONS

Variant		EK-TRON 5.300 G-E	EK-TRON 6.350 G-E	EK-TRON 6.400 G-E	EK-TRON 7.500 G-E	EK-TRON 7.600 G-E
72H	KN	3148794	3148795	3148796	3148797	3148798
	KM	3148498	3148500	3148502	3148504	3148506
	KL	3148499	3148501	3148503	3148505	3148507
FCE	KN	3148804	3148805	3148806	3148807	3148808
	KM	3148522	3148524	3148526	3148528	3148530
	KL	3148523	3148525	3148527	3148529	3148531
72H + FCE	KN	3148809	3148810	3148811	3148812	3148813
	KM	3148534	3148536	3148538	3148540	3148542
	KL	3148535	3148537	3148539	3148541	3148543

GAS TRAINS AND FILTERS

DUNGS models	Code	SIEMENS models	Code	Filters	Code
GT-D1-MBEVB-RP50-PS2	3148693	GT-S1-VGD20-RP50-PS2	3148683	FG-Rp2"	3757200
GT-D1-MBEVB-DN65-PS2	3148694	GT-S1-VGD40-DN65-PS2	3148684	FG-DN65	3757198
GT-D1-MBEVB-DN80-PS2	3148695	GT-S1-VGD40-DN80-PS2	3148685	FG-DN80	3757201
GT-D1-MBEVB-DN100-PS2	3148696	GT-S1-VGD40-DN100-PS2	3148686	FG-DN100	3757195
		GT-S1-VGD40-DN125-PS2	3148687	FG-DN125	3757209



DIMENSIONS (mm)

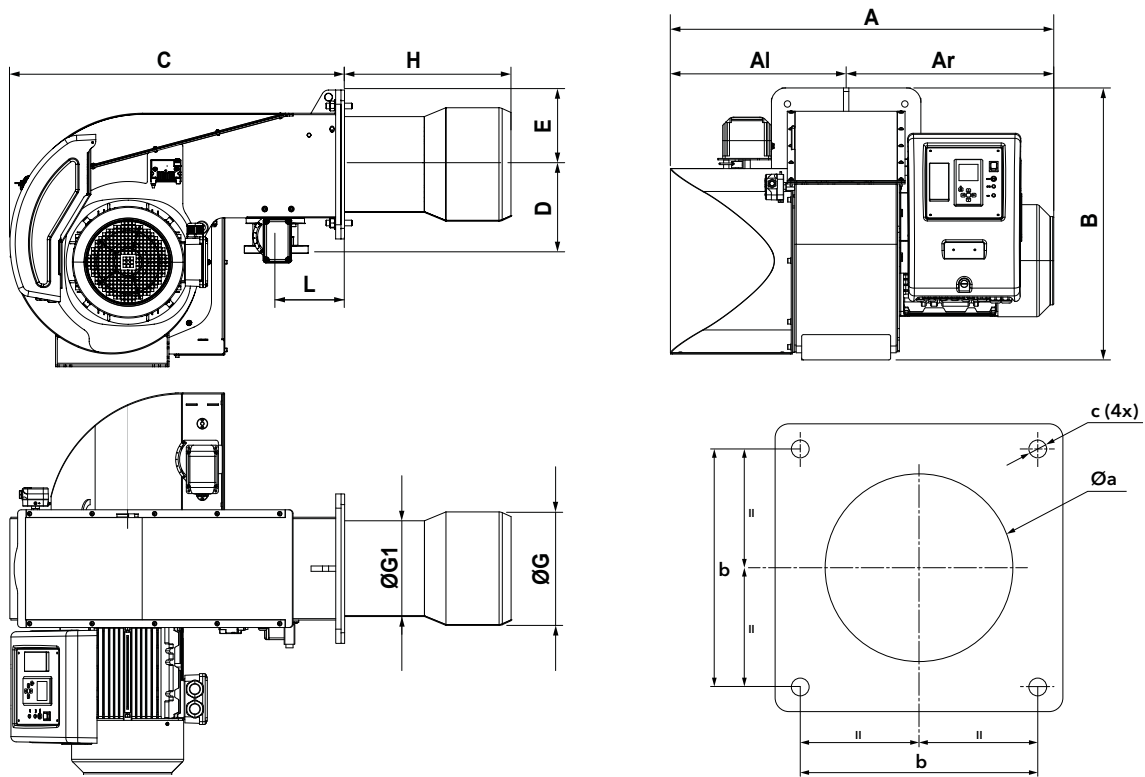

Model	A	A1	Ar	B	C	D	E	ØG	ØG1	H			L	Øa	b	c
										KN	KM	KL				
EK-TRON 5.300 G-E	813	356	457	606	714	245	190	300	216	385	485	585	125	315-325	315	M16
EK-TRON 6.350 G-E	875	387	488	684	828	245	190	290	240	328	428	528	195	305-315	315	M16
EK-TRON 6.400 G-E	875	387	488	684	828	250	190	320	270	392	448	563	195	335-345	315	M16
EK-TRON 7.500 G-E	1083	494	589	780	943	251	210	320	270	373	470	573	195	335-345	330	M16
EK-TRON 7.600 G-E	1083	494	589	780	943	251	210	360	270	373	470	573	195	375-385	330	M16

PACKAGING

The burner is delivered on a pallet with:

- burner body and combustion head (to be mounted by the installer)
- gas train and filter
- boiler fixing accessories
- technical documentation

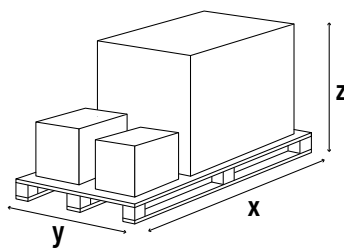

Model	Dimensions (mm)		
	X	Y	Z
EK-TRON 5.300 G-E	1100	900	720
EK-TRON 6.350 G-E	1100	900	720
EK-TRON 6.400 G-E	1100	900	720
EK-TRON 7.500 G-E	1300	1050	900
EK-TRON 7.600 G-E	1300	1050	900

EK-TRON 5 G-E / EK-TRON 6 G-E / EK-TRON 7 G-E

340 ... 6050 kW

Two stage progressive/modulating electronic

PRESSURE LOSS [BURNER HEAD + GAS TRAIN] (mbar)

EK-TRON 5.300 G-E

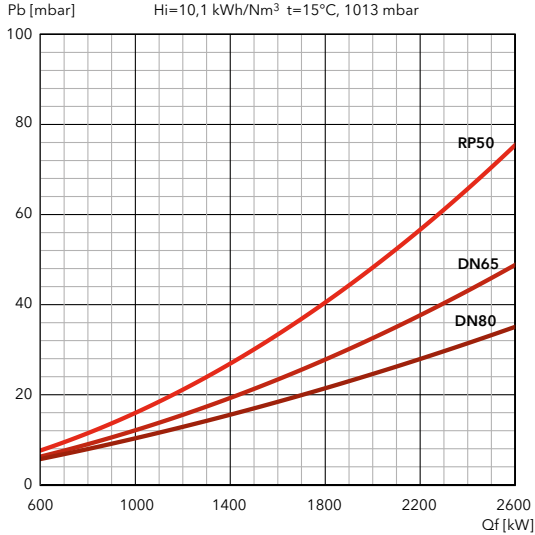

i Each gas train must be installed with its own **connection pipe**, to be selected from the following table:

Gas train model	Code	Connection pipe
GT-S1-VGD20-RP50-PS2	3148683	3144686
GT-S1-VGD40-DN65-PS2	3148684	3148771
GT-S1-VGD40-DN80-PS2	3148685	3148772
GT-D1-MBEVB-RP50-PS2	3148693	3144686
GT-D1-MBEVB-DN65-PS2	3148694	3148771
GT-D1-MBEVB-DN80-PS2	3148695	3148772

Dimensions of gas trains and connection pipes: see page 304

EK-TRON 6.350 G-E

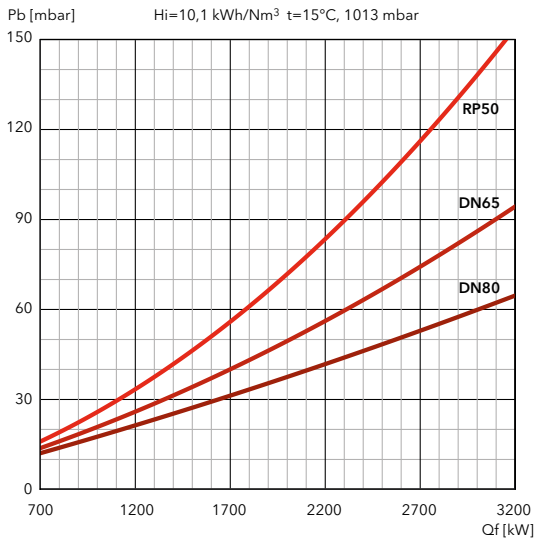

i Each gas train must be installed with its own **connection pipe**, to be selected from the following table:

Gas train model	Code	Connection pipe
GT-S1-VGD20-RP50-PS2	3148683	3144686
GT-S1-VGD40-DN65-PS2	3148684	3148771
GT-S1-VGD40-DN80-PS2	3148685	3148772
GT-D1-MBEVB-RP50-PS2	3148693	3144686
GT-D1-MBEVB-DN65-PS2	3148694	3148771
GT-D1-MBEVB-DN80-PS2	3148695	3148772

Dimensions of gas trains and connection pipes: see page 304

EK-TRON 6.400 G-E

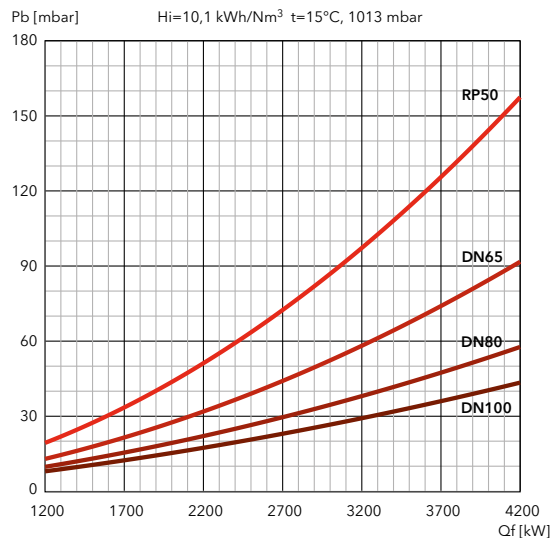

i Each gas train must be installed with its own **connection pipe**, to be selected from the following table:

Gas train model	Code	Connection pipe
GT-S1-VGD20-RP50-PS2	3148683	3148770
GT-S1-VGD40-DN65-PS2	3148684	3145997
GT-S1-VGD40-DN80-PS2	3148685	3145864
GT-S1-VGD40-DN100-PS2	3148686	3145821
GT-D1-MBEVB-RP50-PS2	3148693	3148770
GT-D1-MBEVB-DN65-PS2	3148694	3145997
GT-D1-MBEVB-DN80-PS2	3148695	3145864
GT-D1-MBEVB-DN100-PS2	3148696	3145821

Dimensions of gas trains and connection pipes: see page 304



PRESSURE LOSS [BURNER HEAD + GAS TRAIN] (mbar)

EK-TRON 7.500 G-E

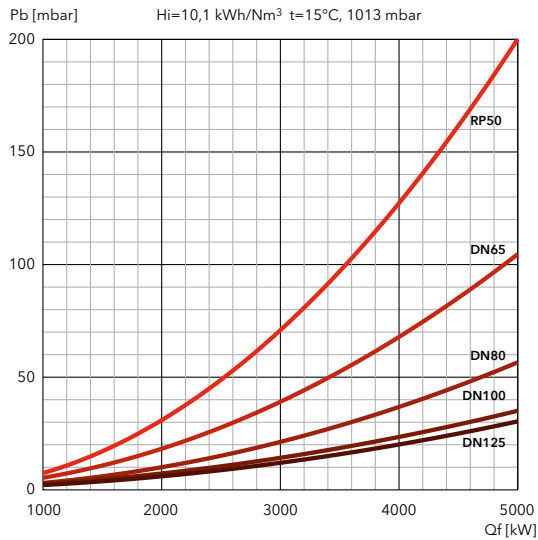

i Each gas train must be installed with its own **connection pipe**, to be selected from the following table:

Gas train model	Code	Connection pipe
GT-S1-VGD20-RP50-PS2	3148683	3148770
GT-S1-VGD40-DN65-PS2	3148684	3148766
GT-S1-VGD40-DN80-PS2	3148685	3148767
GT-S1-VGD40-DN100-PS2	3148686	3148768
GT-S1-VGD40-DN125-PS2	3148687	3148769
GT-D1-MBEVB-RP50-PS2	3148693	3148770
GT-D1-MBEVB-DN65-PS2	3148694	3148766
GT-D1-MBEVB-DN80-PS2	3148695	3148767
GT-D1-MBEVB-DN100-PS2	3148696	3148768

Dimensions of gas trains and connection pipes: see page 304

EK-TRON 7.600 G-E

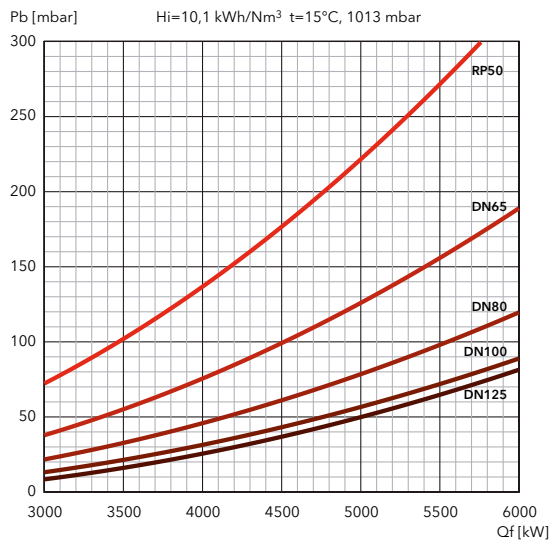

i Each gas train must be installed with its own **connection pipe**, to be selected from the following table:

Gas train model	Code	Connection pipe
GT-S1-VGD20-RP50-PS2	3148683	3148770
GT-S1-VGD40-DN65-PS2	3148684	3148766
GT-S1-VGD40-DN80-PS2	3148685	3148767
GT-S1-VGD40-DN100-PS2	3148686	3148768
GT-S1-VGD40-DN125-PS2	3148687	3148769
GT-D1-MBEVB-RP50-PS2	3148693	3148770
GT-D1-MBEVB-DN65-PS2	3148694	3148766
GT-D1-MBEVB-DN80-PS2	3148695	3148767
GT-D1-MBEVB-DN100-PS2	3148696	3148768

Dimensions of gas trains and connection pipes: see page 304

FILTERS

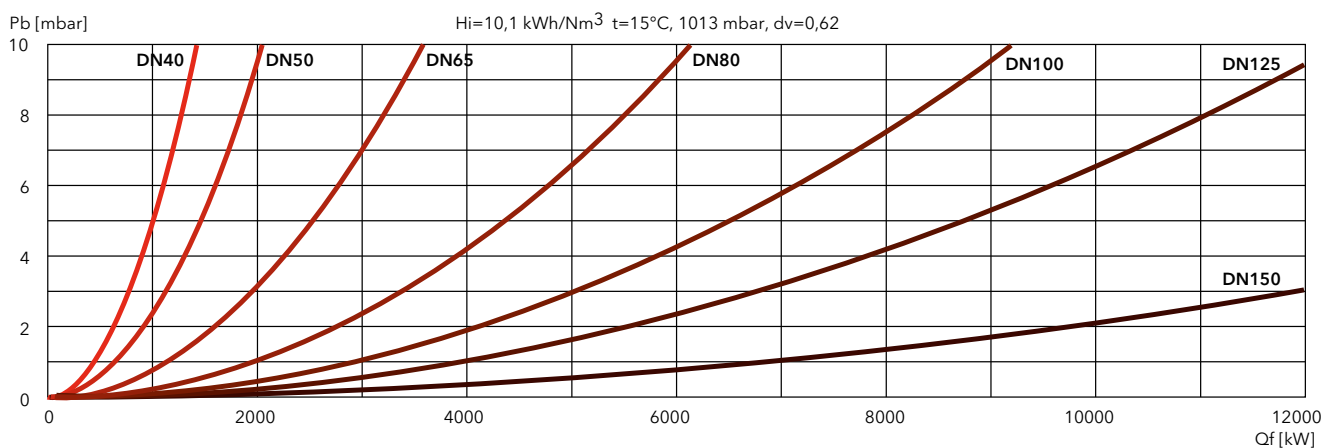

EK-TRON 5 G-R / EK-TRON 6 G-R / EK-TRON 7 G-R

340 ... 6050 kW

Two stage progressive/modulating mechanical



- **Fuel:** natural gas, Hi = 6,99 ... 11,39 kWh/Nm³
- **Emissions:** Low NOx class 2 burners (≤120 mg/kWh) according to EN676 Directive
- **Protection level:** IP 40

TECHNICAL DATA

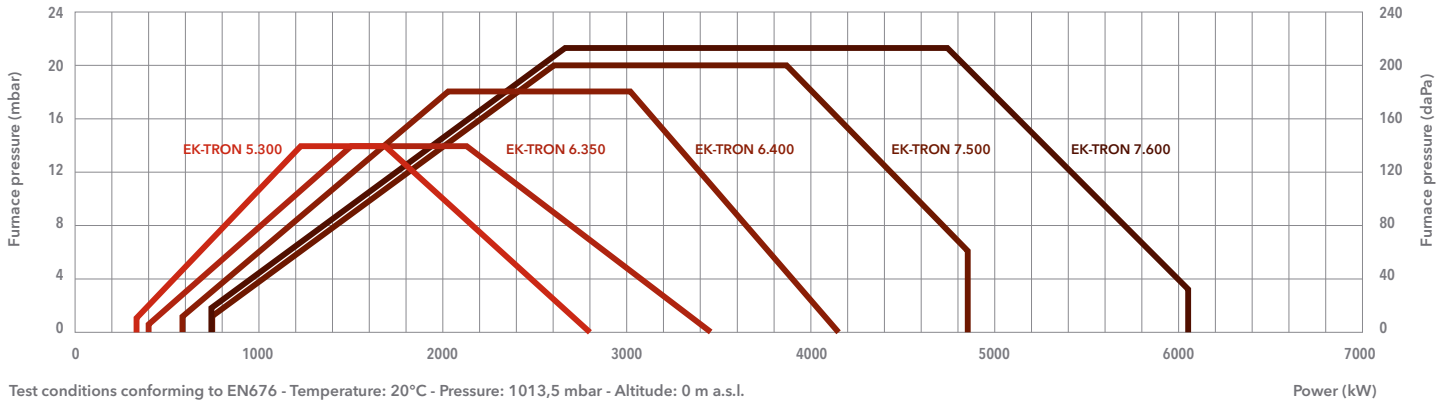

Test conditions conforming to EN676 - Temperature: 20°C - Pressure: 1013,5 mbar - Altitude: 0 m a.s.l.

	EK-TRON 5.300 G-R	EK-TRON 6.350 G-R	EK-TRON 6.400 G-R	EK-TRON 7.500 G-R	EK-TRON 7.600 G-R
Operating range	340 – 2800 kW	400 – 3450 kW	590 – 4150 kW	750 – 4850 kW	740 – 6050 kW
Gas connection	DN50	DN50	DN65	DN65	DN65
Control box / flame detector	LME73* / ionization	LME73* / ionization	LME73* / ionization	LME73* / ionization	LME73* / ionization
Auxiliary voltage	1NPE AC 230 V - 50 Hz TN-S	1NPE AC 230 V - 50 Hz TN-S	1NPE AC 230 V - 50 Hz TN-S	1NPE AC 230 V - 50 Hz TN-S	1NPE AC 230 V - 50 Hz TN-S
Power supply	3NPE AC 400 V - 50 Hz	3NPE AC 400 V - 50 Hz	3NPE AC 400 V - 50 Hz	3NPE AC 400 V - 50 Hz	3NPE AC 400 V - 50 Hz
Fan motor	4 kW	5,5 kW	7,5 kW	11 kW	15 kW
Acoustic level	<83 dB(A)	<84 dB(A)	<85 dB(A)	<85 dB(A)	<85 dB(A)
Burner codes (body + head)	KN	3148789	3148790	3148791	3148793
	KM	3148337	3148339	3148341	3148345
	KL	3148338	3148340	3148342	3148346

*: LME75 for 72H versions

OTHER AVAILABLE VERSIONS

Variant	EK-TRON 5.300 G-R	EK-TRON 6.350 G-R	EK-TRON 6.400 G-R	EK-TRON 7.500 G-R	EK-TRON 7.600 G-R
72H	KN	3148799	3148800	3148801	3148803
	KM	3148510	3148512	3148514	3148518
	KL	3148511	3148513	3148515	3148519

GAS TRAINS AND FILTERS

DUNGS models	Code	SIEMENS models	Code	Filters	Code
GT-D1-MBEVB-RP50-PS3	3148697	GT-S1-VGD20-RP50-PS3	3148688	FG-Rp2"	3757200
GT-D1-MBEVB-DN65-PS3	3148698	GT-S1-VGD40-DN65-PS3	3148689	FG-DN65	3757198
GT-D1-MBEVB-DN80-PS3	3148699	GT-S1-VGD40-DN80-PS3	3148690	FG-DN80	3757201
GT-D1-MBEVB-DN100-PS3	3148700	GT-S1-VGD40-DN100-PS3	3148691	FG-DN100	3757195
		GT-S1-VGD40-DN125-PS3	3148692	FG-DN125	3757209

DIMENSIONS (mm)

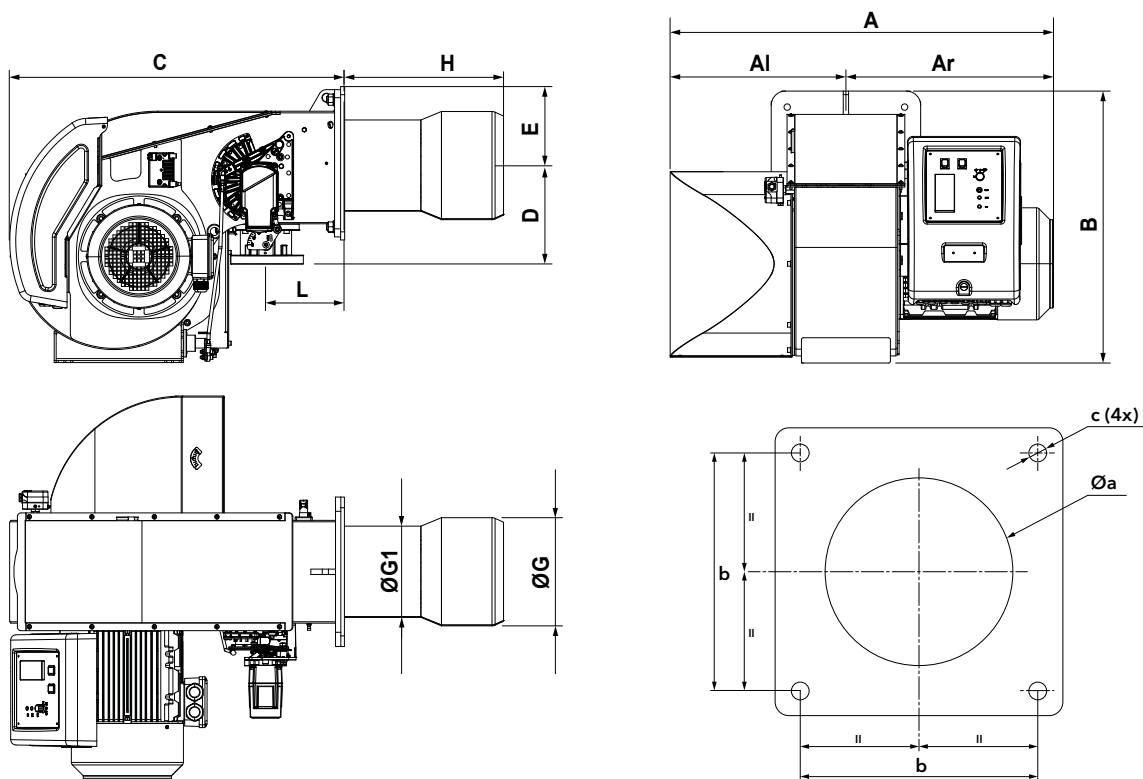

Model	A	AI	Ar	B	C	D	E	ØG	ØG1	H			L	Øa	b	c
										KN	KM	KL				
EK-TRON 5.300 G-R	813	356	457	606	714	245	190	300	216	385	485	585	125	315-325	315	M16
EK-TRON 6.350 G-R	875	387	488	684	828	245	190	290	240	328	428	528	195	305-315	315	M16
EK-TRON 6.400 G-R	875	387	488	684	828	250	190	320	270	392	448	563	195	335-345	315	M16
EK-TRON 7.500 G-R	1083	494	589	780	943	251	210	320	270	373	470	573	195	335-345	330	M16
EK-TRON 7.600 G-R	1083	494	589	780	943	251	210	360	270	373	470	573	195	375-385	330	M16

PACKAGING

The burner is delivered on a pallet with:

- burner body and combustion head (to be mounted by the installer)
- gas train and filter
- boiler fixing accessories
- technical documentation

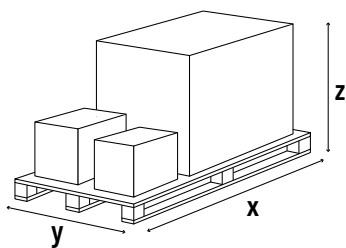

Model	Dimensions (mm)		
	X	Y	Z
EK-TRON 5.300 G-R	1100	900	720
EK-TRON 6.350 G-R	1100	900	720
EK-TRON 6.400 G-R	1100	900	720
EK-TRON 7.500 G-R	1300	1050	900
EK-TRON 7.600 G-R	1300	1050	900

EK-TRON 5 G-R / EK-TRON 6 G-R / EK-TRON 7 G-R

340 ... 6050 kW

Two stage progressive/modulating mechanical

PRESSURE LOSS [BURNER HEAD + GAS TRAIN] (mbar)

EK-TRON 5.300 G-R

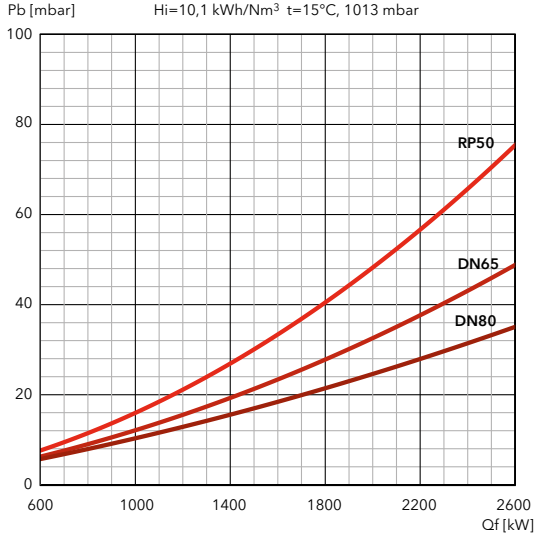

i Each gas train must be installed with its own **connection pipe**, to be selected from the following table:

Gas train model	Code	Connection pipe
GT-S1-VGD20-RP50-PS3	3148688	3144686
GT-S1-VGD40-DN65-PS3	3148689	3148771
GT-S1-VGD40-DN80-PS3	3148690	3148772
GT-D1-MBEVB-RP50-PS3	3148697	3144686
GT-D1-MBEVB-DN65-PS3	3148698	3148771
GT-D1-MBEVB-DN80-PS3	3148699	3148772

Dimensions of gas trains and connection pipes: see page 304

EK-TRON 6.350 G-R

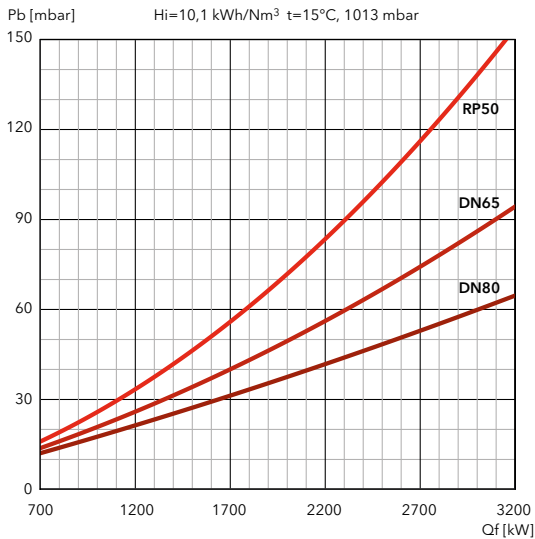

i Each gas train must be installed with its own **connection pipe**, to be selected from the following table:

Gas train model	Code	Connection pipe
GT-S1-VGD20-RP50-PS3	3148688	3144686
GT-S1-VGD40-DN65-PS3	3148689	3148771
GT-S1-VGD40-DN80-PS3	3148690	3148772
GT-D1-MBEVB-RP50-PS3	3148697	3144686
GT-D1-MBEVB-DN65-PS3	3148698	3148771
GT-D1-MBEVB-DN80-PS3	3148699	3148772

Dimensions of gas trains and connection pipes: see page 304

EK-TRON 6.400 G-R

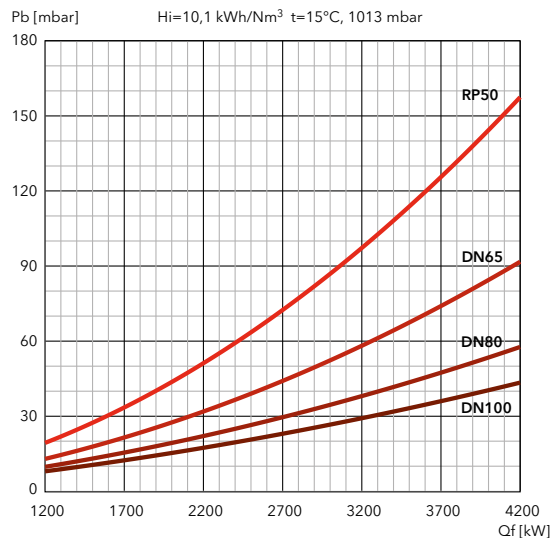

i Each gas train must be installed with its own **connection pipe**, to be selected from the following table:

Gas train model	Code	Connection pipe
GT-S1-VGD20-RP50-PS3	3148688	3148770
GT-S1-VGD40-DN65-PS3	3148689	3145997
GT-S1-VGD40-DN80-PS3	3148690	3145864
GT-S1-VGD40-DN100-PS3	3148691	3145821
GT-D1-MBEVB-RP50-PS3	3148697	3148770
GT-D1-MBEVB-DN65-PS3	3148698	3145997
GT-D1-MBEVB-DN80-PS3	3148699	3145864
GT-D1-MBEVB-DN100-PS3	3148700	3145821

Dimensions of gas trains and connection pipes: see page 304

PRESSURE LOSS [BURNER HEAD + GAS TRAIN] (mbar)

EK-TRON 7.500 G-R

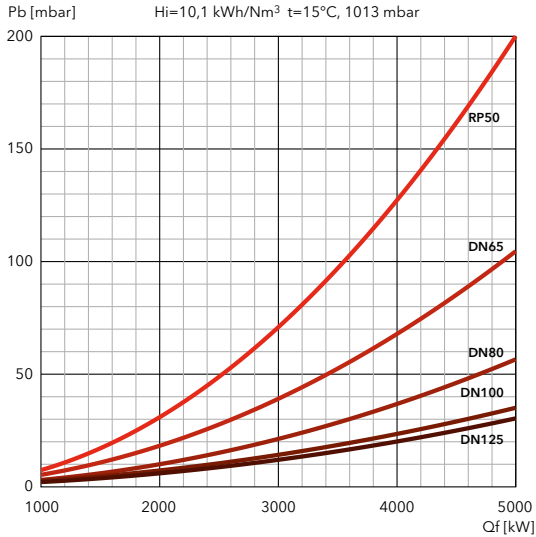

i Each gas train must be installed with its own **connection pipe**, to be selected from the following table:

Gas train model	Code	Connection pipe
GT-S1-VGD20-RP50-PS3	3148688	3148770
GT-S1-VGD40-DN65-PS3	3148689	3148766
GT-S1-VGD40-DN80-PS3	3148690	3148767
GT-S1-VGD40-DN100-PS3	3148691	3148768
GT-S1-VGD40-DN125-PS3	3148692	3148769
GT-D1-MBEVB-RP50-PS3	3148697	3148770
GT-D1-MBEVB-DN65-PS3	3148698	3148766
GT-D1-MBEVB-DN80-PS3	3148699	3148767
GT-D1-MBEVB-DN100-PS3	3148700	3148768

Dimensions of gas trains and connection pipes: see page 304

EK-TRON 7.600 G-R

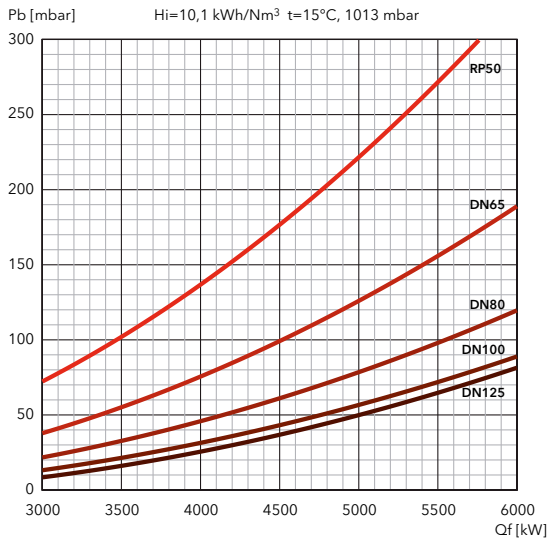

i Each gas train must be installed with its own **connection pipe**, to be selected from the following table:

Gas train model	Code	Connection pipe
GT-S1-VGD20-RP50-PS3	3148688	3148770
GT-S1-VGD40-DN65-PS3	3148689	3148766
GT-S1-VGD40-DN80-PS3	3148690	3148767
GT-S1-VGD40-DN100-PS3	3148691	3148768
GT-S1-VGD40-DN125-PS3	3148692	3148769
GT-D1-MBEVB-RP50-PS3	3148697	3148770
GT-D1-MBEVB-DN65-PS3	3148698	3148766
GT-D1-MBEVB-DN80-PS3	3148699	3148767
GT-D1-MBEVB-DN100-PS3	3148700	3148768

Dimensions of gas trains and connection pipes: see page 304

FILTERS

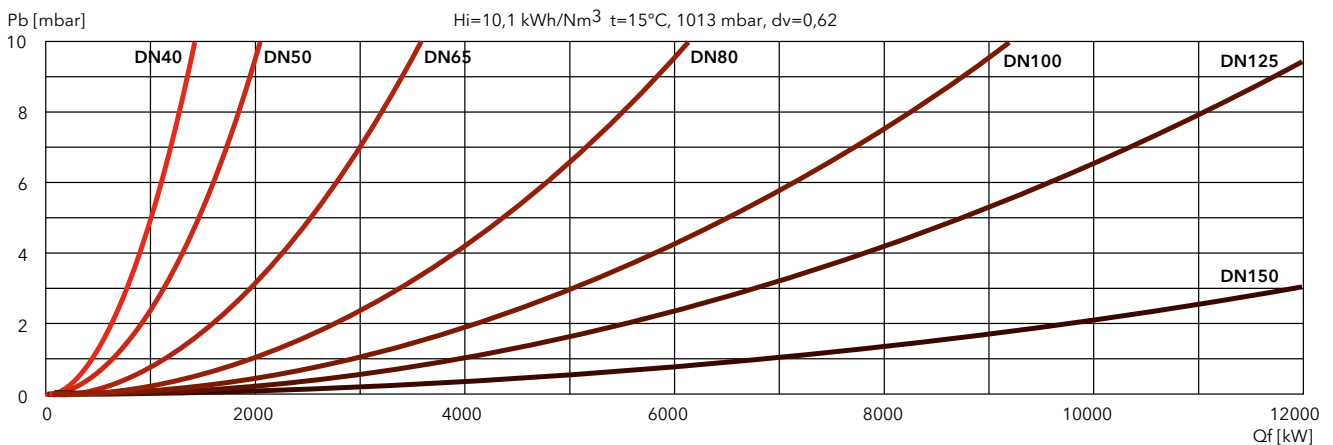

EK-TRON 5 GL-EX2

320 ... 2160 kW

Two stage progressive/modulating electronic



- **Fuels:** natural gas, Hi = 6,99 ... 11,39 kWh/Nm³
light oil, viscosity 6 mm²/s at 20°C, Hi = 11,86 kWh/kg
- **Emissions:** Low NOx class 3 (≤80 mg/kWh) according to EN676 in gas
Low NOx class 2 (≤185 mg/kWh) according to EN267 in light oil
- **Protection level:** IP 40

TECHNICAL DATA

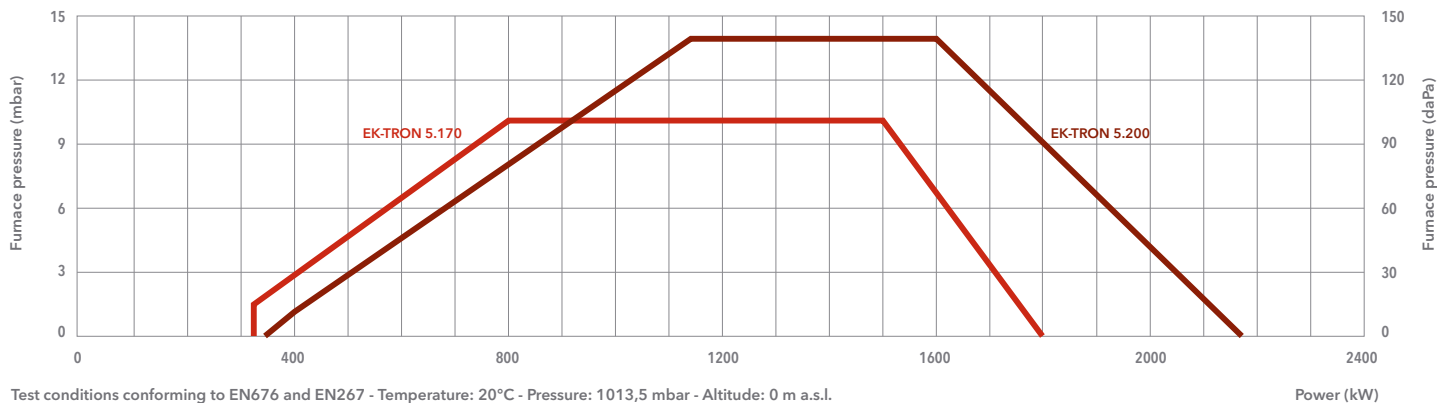

Test conditions conforming to EN676 and EN267 - Temperature: 20°C - Pressure: 1013,5 mbar - Altitude: 0 m a.s.l.

		EK-TRON 5.170 GL-EX2	EK-TRON 5.200 GL-EX2
Operating range		320 - 1800 kW	340 - 2160 kW
Gas connection		DN50	DN50
Control box / flame detector		BT335 / UV cell	BT335 / UV cell
Auxiliary voltage		1NPE AC 230 V - 50 Hz TN-S	1NPE AC 230 V - 50 Hz TN-S
Power supply		3NPE AC 400 V - 50 Hz	3NPE AC 400 V - 50 Hz
Fan motor		50 Hz - 3 kW	50 Hz - 4 kW
Acoustic level		< 75 dB(A)	< 80 dB(A)
Burner codes (body + head)	KN	3149001	3149003
	KL	3149002	3149004

OTHER AVAILABLE VERSIONS

Variant		EK-TRON 5.170 GL-EX2	EK-TRON 5.200 GL-EX2
72H	KM	3149105	3149107
	KL	3149106	3149108
FCE	KM	3149119	3149121
	KL	3149120	3149122
72H + FCE	KM	3149133	3149135
	KL	3149134	3149136
FCO	KM	3149147	3149149
	KL	3149148	3149150
72H + FCO	KM	3149161	3149163
	KL	3149162	3149164

GAS TRAINS AND FILTERS

DUNGS models	Code
GT-D1-MBDLE415-RP40-PS2	3149611
GT-D1-MBDLE420-RP50-PS2	3149612

SIEMENS models	Code
GT-S1-VGD20-RP50-PS2	3148683
GT-S1-VGD40-DN65-PS2	3148684
GT-S1-VGD40-DN80-PS2	3148685

Filters	Code
FG-Rp1"1/2	3757199
FG-Rp2"	3757200
FG-DN65	3757198
FG-DN80	3757201



DIMENSIONS (mm)

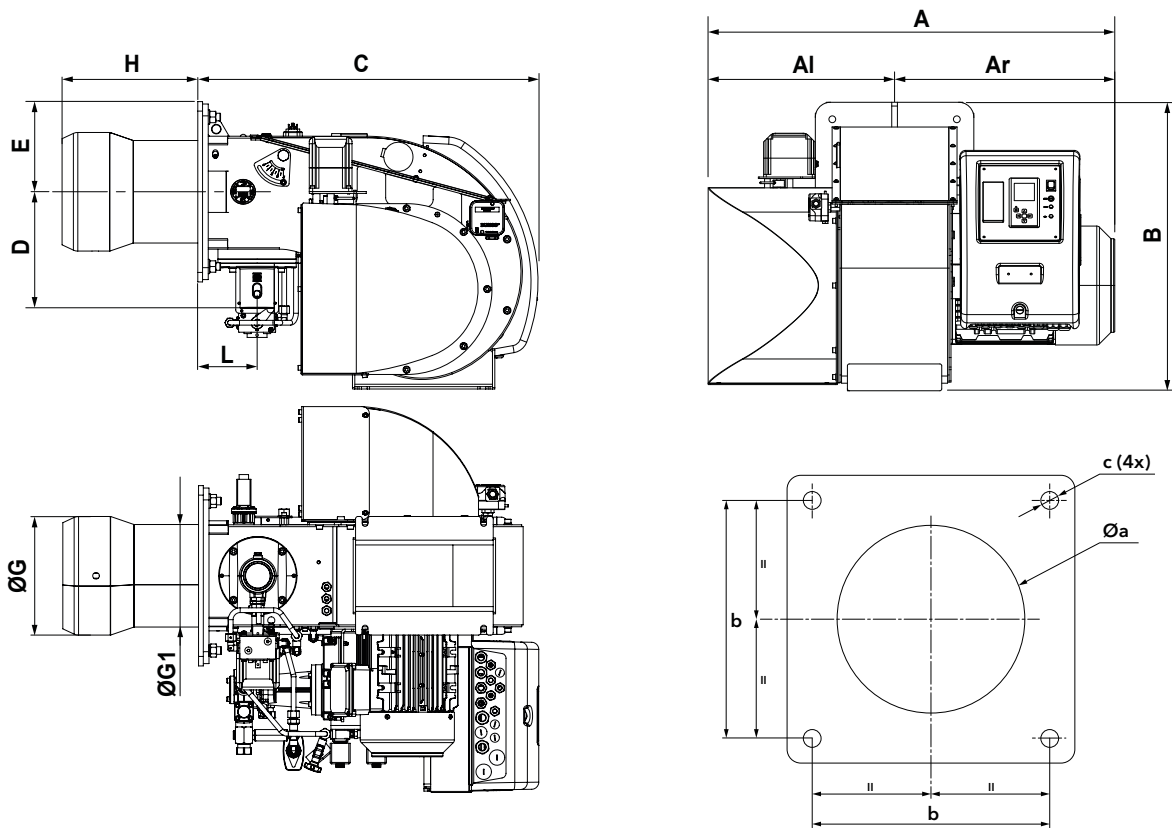

Model	A	Al	Ar	B	C	D	E	ØG	ØG1	H		L	Øa	b	c
										KN	KL				
EK-TRON 5.170	813	356	457	606	717	245	190	250	216	286	486	125	265-275	315	M16
EK-TRON 5.200	813	356	457	606	717	245	190	270	216	286	486	125	265-275	315	M16

PACKAGING

The burner is delivered on a pallet with:

- burner body and combustion head (to be mounted by the installer)
- gas train and filter
- boiler fixing accessories
- technical documentation

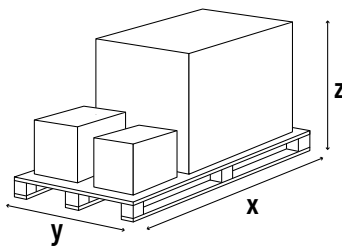

Model	Dimensions (mm)		
	X	Y	Z
EK-TRON 5.170	1100	900	720
EK-TRON 5.200	1100	900	720

i Nozzles not included, to be added in case of order: see page 63

EK-TRON 5 GL-EX2

320 ... 2160 kW

Two stage progressive/modulating electronic

PRESSURE LOSS [BURNER HEAD + GAS TRAIN] (mbar)

EK-TRON 5.170 GL-EX2

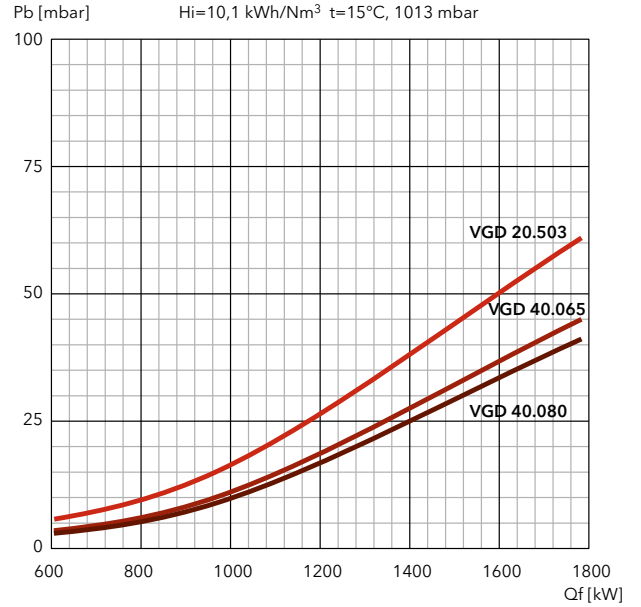
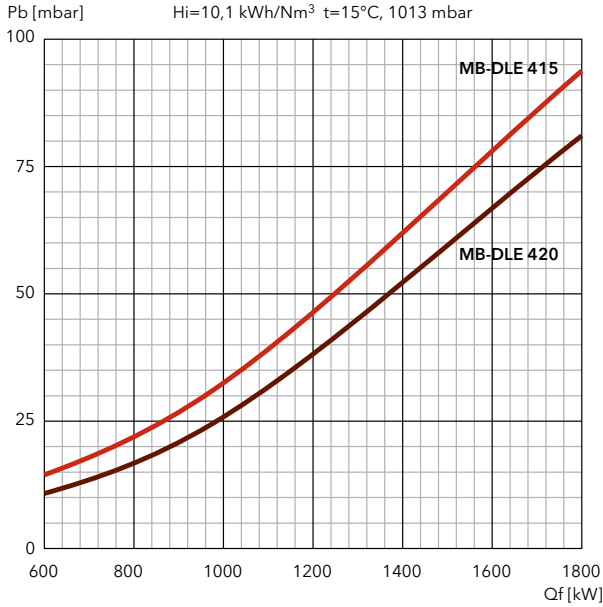

i Each gas train must be installed with its own **connection pipe**, to be selected from the following table:

Gas train model	Code	Connection pipe
GT-D1-MBDLE415-RP40-PS2	3149611	3144686
GT-D1-MBDLE420-RP50-PS2	3149612	3144686
GT-S1-VGD20-RP50-PS2	3148683	3144686
GT-S1-VGD40-DN65-PS2	3148684	3148771
GT-S1-VGD40-DN80-PS2	3148685	3148772

Dimensions of gas trains and connection pipes: see page 306

FILTERS

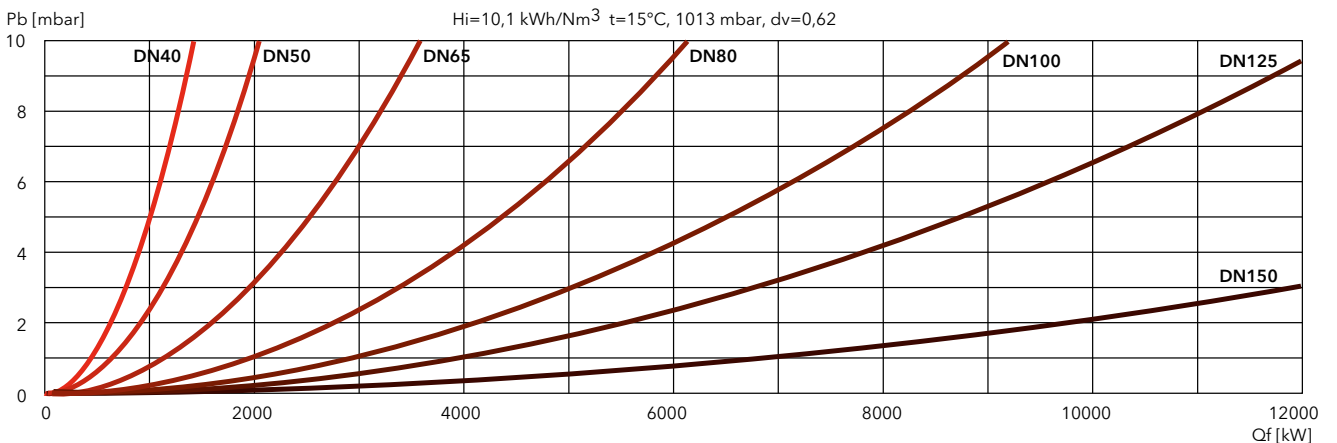



PRESSURE LOSS [BURNER HEAD + GAS TRAIN] (mbar)

EK-TRON 5.200 GL-EX2

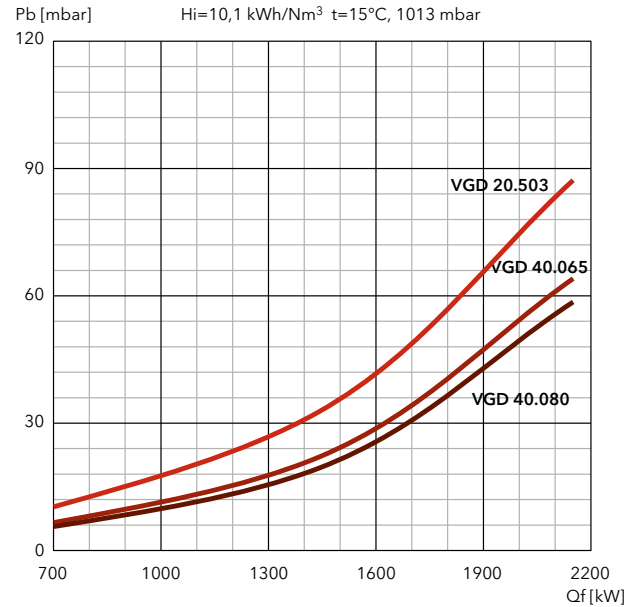
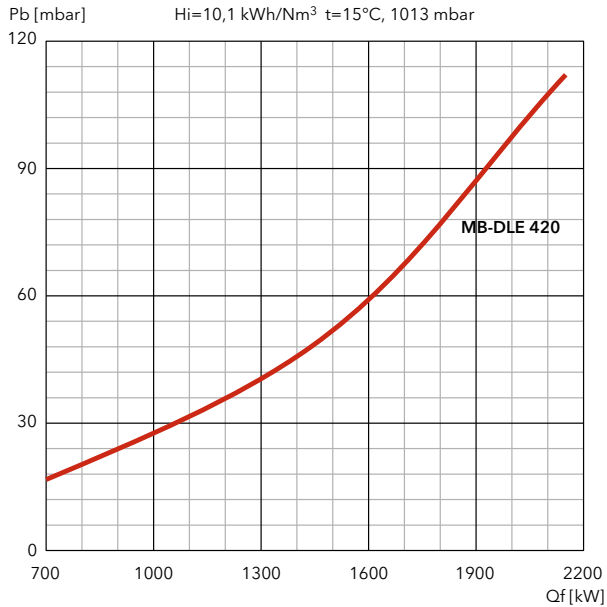

i Each gas train must be installed with its own **connection pipe**, to be selected from the following table:

Gas train model	Code	Connection pipe
GT-D1-MBDLE420-RP50-PS2	3149612	3144686
GT-S1-VGD20-RP50-PS2	3148683	3144686
GT-S1-VGD40-DN65-PS2	3148684	3148771
GT-S1-VGD40-DN80-PS2	3148685	3148772

Dimensions of gas trains and connection pipes: see page 306

FILTERS

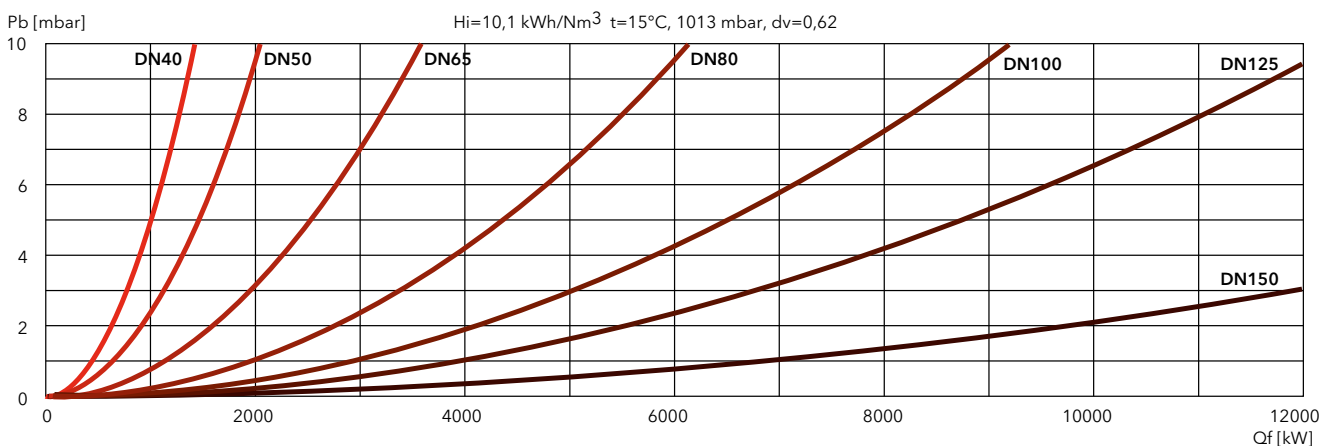

EK-TRON 6 GL-EX2

600 ... 3900 kW

Two stage progressive/modulating electronic



- **Fuels:** natural gas, Hi = 6,99 ... 11,39 kWh/Nm³
light oil, viscosity 6 mm²/s at 20°C, Hi = 11,86 kWh/kg
- **Emissions:** Low NOx class 3 (≤80 mg/kWh) according to EN676 in gas
Low NOx class 2 (≤185 mg/kWh) according to EN267 in light oil
- **Protection level:** IP 40

TECHNICAL DATA

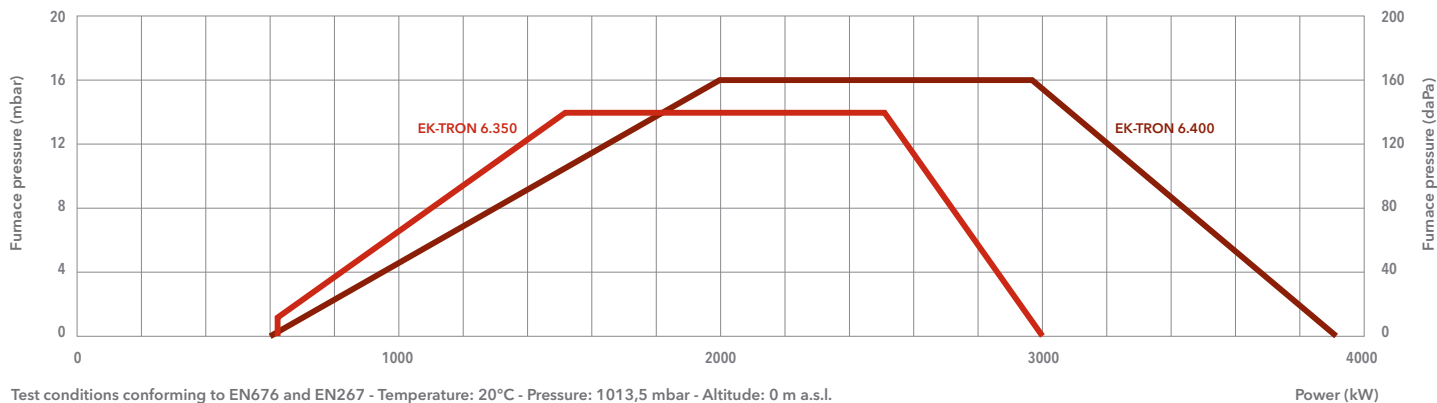

Test conditions conforming to EN676 and EN267 - Temperature: 20°C - Pressure: 1013,5 mbar - Altitude: 0 m a.s.l.

	EK-TRON 6.350 GL-EX2	EK-TRON 6.400 GL-EX2								
Operating range	610 – 3200 kW	600 – 3900 kW								
Gas connection	DN50	DN65								
Control box / flame detector	BT335 / KLC20	BT335 / KLC20								
Auxiliary voltage	1NPE AC 230 V - 50 Hz TN-S	1NPE AC 230 V - 50 Hz TN-S								
Power supply	3NPE AC 400 V - 50 Hz	3NPE AC 400 V - 50 Hz								
Fan motor	50 Hz - 5,5 kW	50 Hz - 7,5 kW								
Acoustic level	< 84 dB(A)	< 85 dB(A)								
Burner codes (body + head)	<table border="0"> <tr> <td>KN</td> <td>3149007</td> </tr> <tr> <td>KL</td> <td>3149008</td> </tr> </table>	KN	3149007	KL	3149008	<table border="0"> <tr> <td>KN</td> <td>3149009</td> </tr> <tr> <td>KL</td> <td>3149010</td> </tr> </table>	KN	3149009	KL	3149010
KN	3149007									
KL	3149008									
KN	3149009									
KL	3149010									

OTHER AVAILABLE VERSIONS

Variant		EK-TRON 6.350 GL-EX2	EK-TRON 6.400 GL-EX2
72H	KN	3149111	3149113
	KL	3149112	3149114
FCE	KN	3149125	3149127
	KL	3149126	3149128
72H + FCE	KN	3149139	3149141
	KL	3149140	3149142
FCO	KN	3149153	3149155
	KL	3149154	3149156
72H + FCO	KN	3149167	3149169
	KL	3149168	3149170

GAS TRAINS AND FILTERS

DUNGS models	Code	SIEMENS models	Code	Filters	Code
GT-D1-MBEVB-RP50-PS2	3148693	GT-S1-VGD20-RP50-PS2	3148683	FG-Rp2"	3757200
GT-D1-MBEVB-DN65-PS2	3148694	GT-S1-VGD40-DN65-PS2	3148684	FG-DN65	3757198
GT-D1-MBEVB-DN80-PS2	3148695	GT-S1-VGD40-DN80-PS2	3148685	FG-DN80	3757201
GT-D1-MBEVB-DN100-PS2	3148696	GT-S1-VGD40-DN100-PS2	3148686	FG-DN100	3757195



DIMENSIONS (mm)

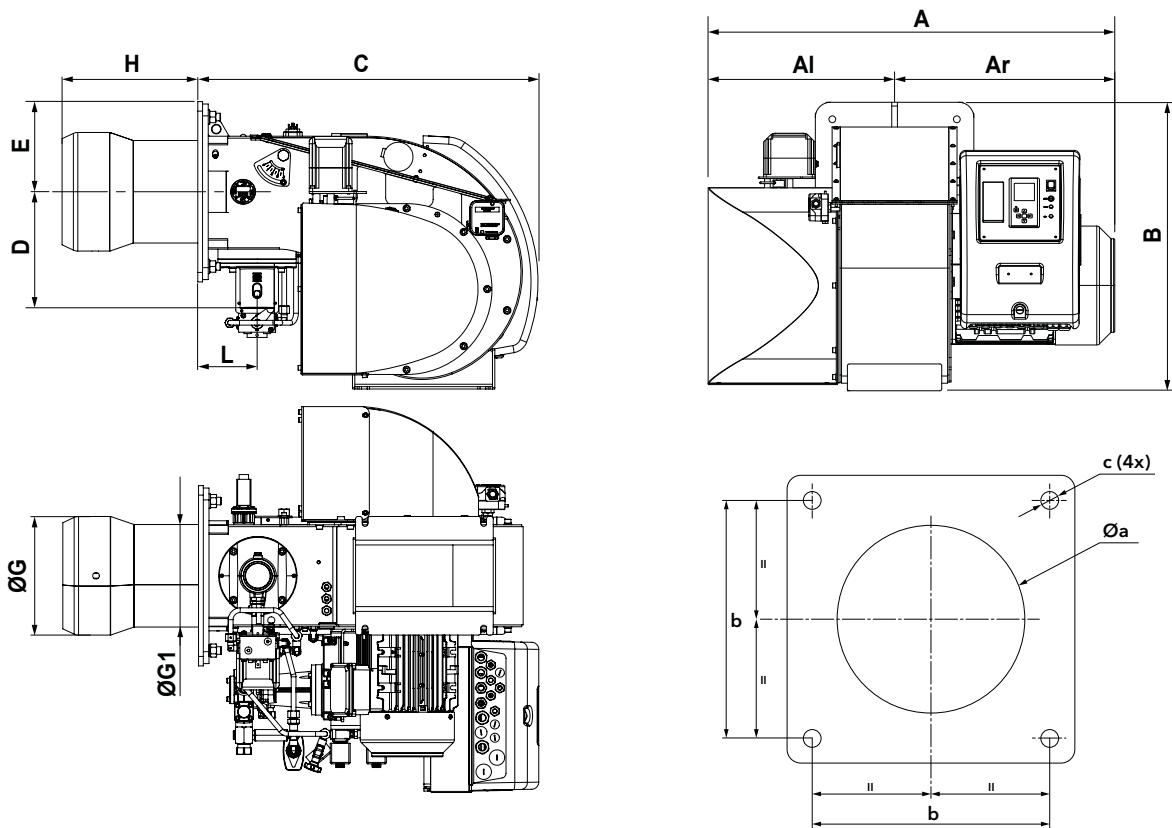

Model	A	Al	Ar	B	C	D	E	ØG	ØG1	H		L	Øa	b	c
										KN	KL				
EK-TRON 6.350	876	388	488	684	830	245	190	290	241	328	528	195	305-315	315	M16
EK-TRON 6.400	876	388	488	684	830	250	190	320	270	344	544	195	335-345	315	M16

PACKAGING

The burner is delivered on a pallet with:

- burner body and combustion head (to be mounted by the installer)
- gas train and filter
- boiler fixing accessories
- technical documentation

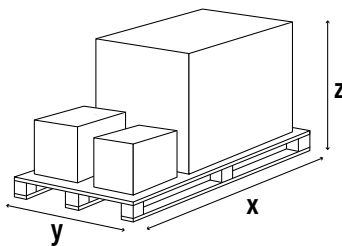

Model	Dimensions (mm)		
	X	Y	Z
EK-TRON 6.350	1100	900	720
EK-TRON 6.400	1100	900	720

i Nozzles not included, to be added in case of order: see page 63

EK-TRON 6 GL-EX2

600 ... 3900 kW

Two stage progressive/modulating electronic

PRESSURE LOSS [BURNER HEAD + GAS TRAIN] (mbar)

EK-TRON 6.350 GL-EX2

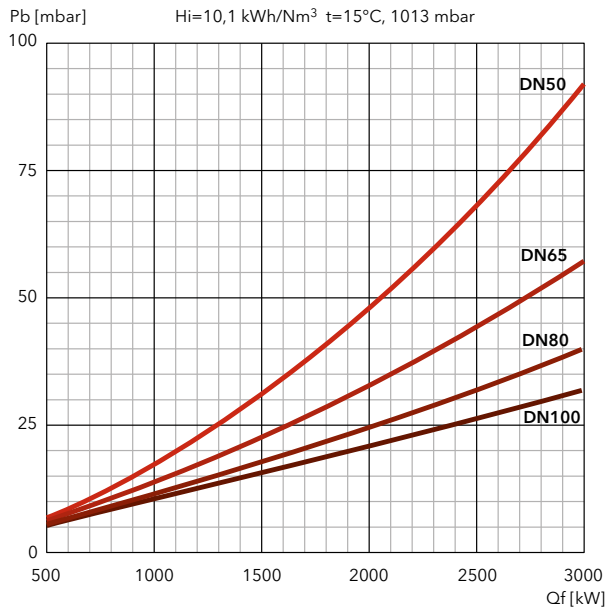

i Each gas train must be installed with its own **connection pipe**, to be selected from the following table:

Gas train model	Code	Connection pipe
GT-S1-VGD20-RP50-PS2	3148683	3144686
GT-S1-VGD40-DN65-PS2	3148684	3148771
GT-S1-VGD40-DN80-PS2	3148685	3148772
GT-S1-VGD40-DN100-PS2	3148686	3148773
GT-D1-MBEVB-RP50-PS2	3148693	3144686
GT-D1-MBEVB-DN65-PS2	3148694	3148771
GT-D1-MBEVB-DN80-PS2	3148695	3148772
GT-D1-MBEVB-DN100-PS2	3148696	3148773

Dimensions of gas trains and connection pipes: see page 304

FILTERS

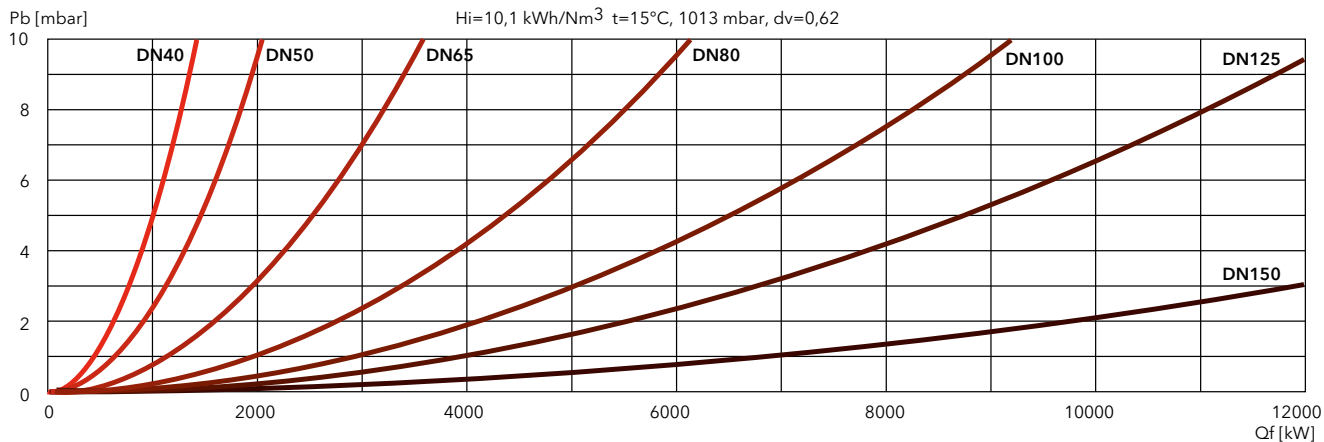



PRESSURE LOSS [BURNER HEAD + GAS TRAIN] (mbar)

EK-TRON 6.400 GL-EX2

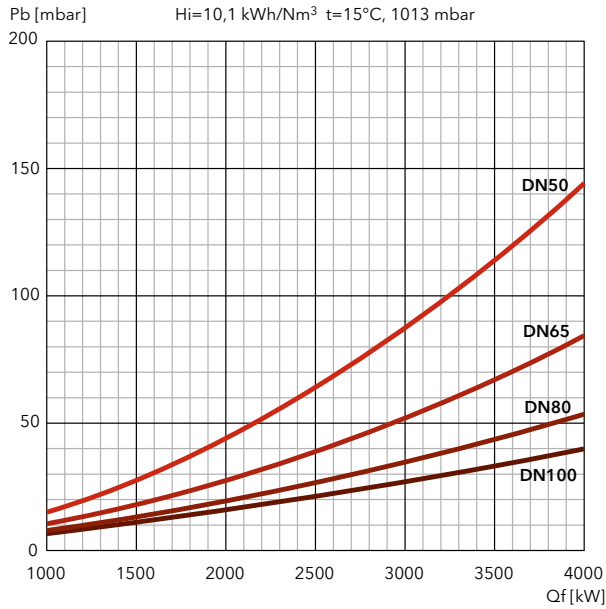

i Each gas train must be installed with its own **connection pipe**, to be selected from the following table:

Gas train model	Code	Connection pipe
GT-S1-VGD20-RP50-PS2	3148683	3148770
GT-S1-VGD40-DN65-PS2	3148684	3148766
GT-S1-VGD40-DN80-PS2	3148685	3148767
GT-S1-VGD40-DN100-PS2	3148686	3148768
GT-D1-MBEVB-RP50-PS2	3148693	3148770
GT-D1-MBEVB-DN65-PS2	3148694	3148766
GT-D1-MBEVB-DN80-PS2	3148695	3148767
GT-D1-MBEVB-DN100-PS2	3148696	3148768

Dimensions of gas trains and connection pipes: see page 304

FILTERS

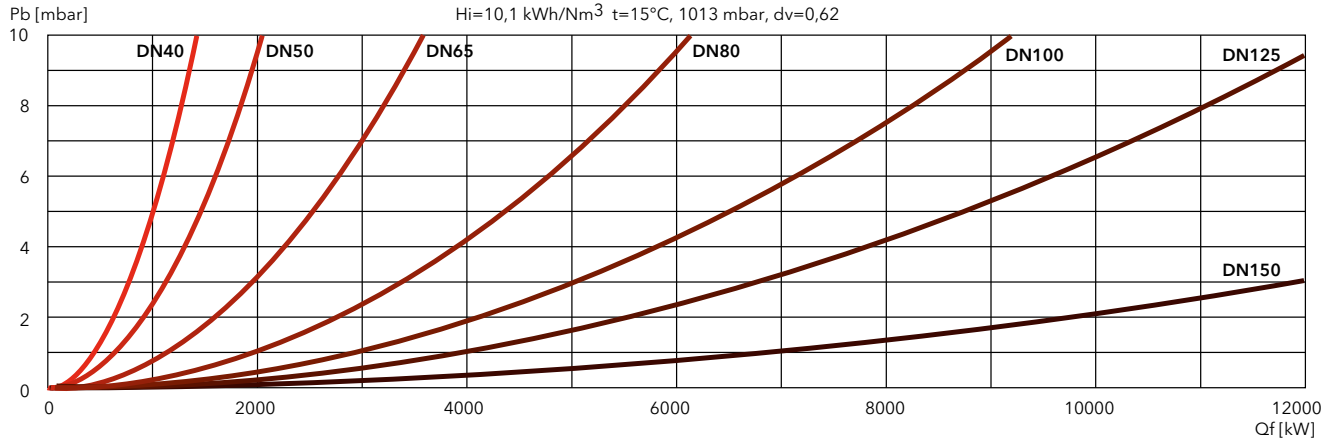

LCM MODULE

Module required for O ₂ control, frequency converter and communication buses connections	3147726
---	---------

COMMUNICATION MODULES

ModBus/BT3 (EBM100) to be mounted on the burner	3147727
ProfiBus/BT3 (PBM100) to be mounted on the burner	3147728

FREQUENCY CONVERTER FOR EXTERNAL INSTALLATION

IP55 with: • EMC filter • Inductor • Control panel	3 kW	3757067
	4 kW	3757068
	5,5 kW	3757069
	7,5 kW	3757070
	11 kW	3757071
	15 kW	3757072

POWER REGULATOR

Power regulator RWF55 stand-alone and kit wiring	3147730
--	---------

PROBES

Temperature probe	Pt100, temperature range: -50° ... 400°C (100 mm) + pocket tube (76 mm)	3750070
Water probe	Temperature range: 0 ... 130°C	3148819
Steam probe	Pressure range: 0 ... 2 bar	3148820
	Pressure range: 0 ... 4 bar	3148821
	Pressure range: 0 ... 10 bar	3148822
	Pressure range: 0 ... 16 bar	3148823
	Pressure range: 0 ... 25 bar	3148824
	Pressure range: 0 ... 40 bar	3148825
Hot air / liquid probe	Temperature range: 0 ... 450°C	3148826
Thermocouple	J type, temperature up to 750°C	3148827

MAX GAS PRESSURE SWITCH

Kit supplied loose Note: this kit is not required for Dungs MBE gas trains, where it is already included	3148675
---	---------

KIT LPG

Kit LPG for EK-TRON G-E and G-R	for EK-TRON 5.300	3149283
	for EK-TRON 6.350, 6.400 and 7.500	3149268
	for EK-TRON 7.600	3149269
Kit LPG for EK-TRON G-EF3 and G-RF3	for EK-TRON 5.300 and 6.350	3149097
	for EK-TRON 6.400	3149098
	for EK-TRON 7.500 and 7.600	3149099

OIL SPILL BACK NOZZLES

Fluidics W2 50° Threaded connection, 7/8"	40 kg/h	3145231
	50 kg/h	3145232
	60 kg/h	3142763
	70 kg/h	3145233
	80 kg/h	3145234
	90 kg/h	3145235
	100 kg/h	3142704
	115 kg/h	3142564
	130 kg/h	3142515
	145 kg/h	3142516
	160 kg/h	3142421
	180 kg/h	3142492
	200 kg/h	3142690
	225 kg/h	3142489
	250 kg/h	3142768
	275 kg/h	3142805
	300 kg/h	3142490
	330 kg/h	3142703
	360 kg/h	3142513
	400 kg/h	3142497
450 kg/h	3142483	
500 kg/h	3142699	
550 kg/h	3142416	
600 kg/h	3142506	

ACOUSTIC SHROUDS

<ul style="list-style-type: none"> • sound level reduction (sound pressure level): ca. 20 ... 30 dB(A) • sheet metal casing, structured coating, isolation with temperature resistant mineral wool • noise absorption material acc. DIN 4102, covered with a glass fibre layer, covered with perforated sheet metal, galvanised • easily disassembled into elements: base plate, side covers, top cover, air inlet section • all elements easily connected via quick locks • height of noise reduction casing adjustable on wheels • feed through for gas, oil and electrical connections integrated in side covers following the requirements • air inlet via noise reduction line • if required, an oil recuperation tub can be integrated on the base plate • for some boiler types a supporting frame for the casing may be necessary, due to the height of the burner tube over the floor <p>Before submitting your order please provide information on the boiler model and the type of installation</p>	Codes on request
--	------------------

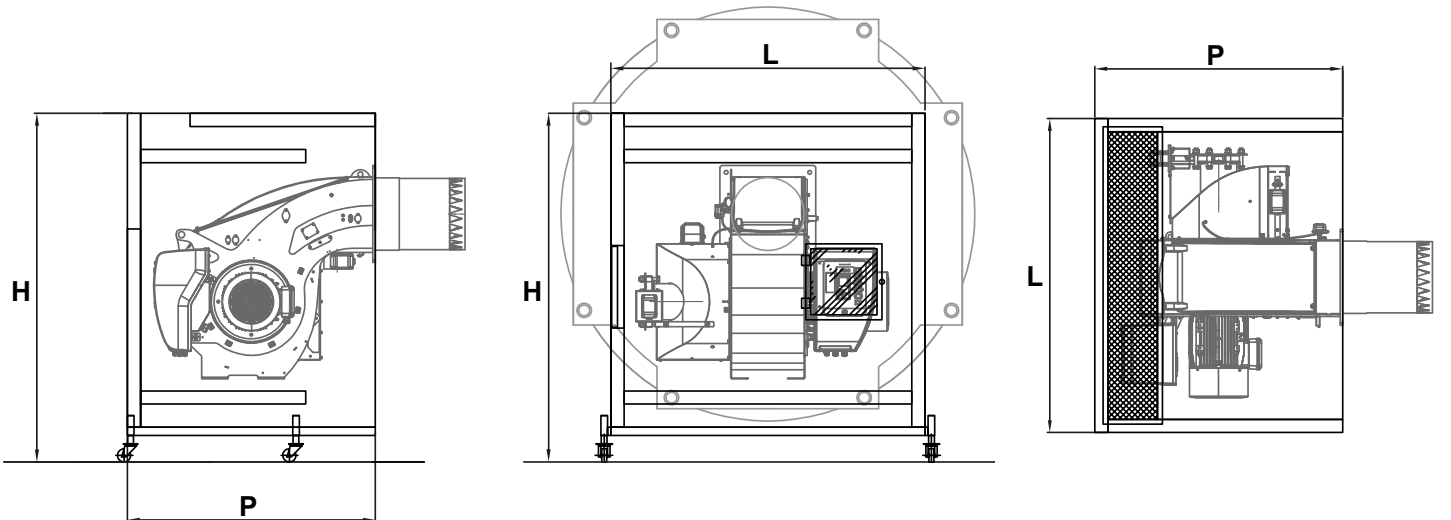

O₂ TRIM FOR BT300, ETAMATIC AND ETAMATIC OEM, FMS/VMS

This kit is used to optimize the combustion in order to keep the air excess as much stable as possible irrespective of the changes that can occur during operations, for instance slight calorific value variations, combustion air temperature and pressure. This improves the seasonal efficiency and therefore reduces the fuel consumption.

The kit includes the following components:

- Lambda transmitter LT3
- Lambda probe LS2
- Probe installation fitting (PIF)
- Gas extraction device (GED)

The control unit has to be installed close to the probe (max 10 m of cable)
 The probe needs a calibration but no reference gas is necessary.
 The display shows the O₂ content.
 Maximum distance between the LT3 and the burner control panel is 500 m.

	Additional LSB modules installed at LT3	GED length	Code
Kit for O₂ trim (LT3 + LS2) Flue temp max 300 °C - Display for O₂ visualization (Note: for models equipped with BT3 this kit needs a LCM module installed in the burner control panel)	none	150 mm	3759296
		300 mm	3759297
		450 mm	3759298
	4x 0/4-20 mA output	150 mm	3759299
		300 mm	3759300
		450 mm	3759301
	4x 0/4-20 mA output + 4x digital output	150 mm	3759302
		300 mm	3759303
		450 mm	3759304

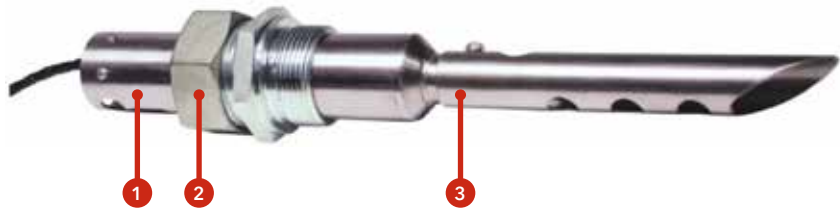

1. Lambda Probe LS2 in standard housing up to 300°C (572°F); default cable length is 2 m (6.5 ft), FEP, with connecting plug
2. Probe installation fitting (PIF)
3. Gas extraction device (GED)

The LS2 lambda probe is equipped with a 2 meter long connection cable that connects the sensor to the transmitter (LT3). It is possible to extend the connection up to a maximum distance of 10 meters (for greater lengths the conformity expires) with a ready-made cable and a probe connection box (PCB).

Description		Code
Extension for LS2	5m ready-made cable	3759318
	PCB (probe connection box)*	3759319

The PCB is a small terminal box that is connected to the 2 meter long cable already existing on the probe. The wiring between the PCB and the transmitter must be carried out on the construction site with suitable cables and trained personnel.

*: the PCB is mandatory if the end user chooses to use his own connecting cable and not one of those proposed (max total length remains 10m)

O₂/CO_e TRIM FOR BT300, ETAMATIC AND ETAMATIC OEM, FMS/VMS

This kit is used for optimizing the combustion in order to keep the air excess as low as possible in order to maximize the seasonal efficiency and therefore minimize the fuel consumption. In addition to the features of the O₂ trim only, this kit reduces the air excess to its minimum because this system continuously measures the content of unburned fuel (CO_e) in the flue: should the air excess be reduced too much, the CO_e raises and the system reacts by increasing the air excess in order to keep firing in safe conditions.

The kit includes the following components:

- Lambda transmitter LT3-F
- Lambda probe KS1D
- Probe installation fitting (PIF)
- Gas extraction device (GED)

The control unit has to be installed close to the probe (max 10 m of cable). The probe needs a calibration but no reference gas is necessary. The display shows the O₂ and CO_e content. Maximum distance between the LT3-F and the burner control panel is 500 m.

	Additional LSB modules installed at LT3-F	GED length	Code
Kit for O₂ trim and CO control (LT3-F + KS1D) Flue temp max 300 °C (Note: for models equipped with BT3 this kit needs a LCM module installed in the burner control panel)	none	150 mm	3759305
		300 mm	3759306
		450 mm	3759307
	4x 0/4-20 mA output	150 mm	3759308
		300 mm	3759309
		450 mm	3759310
	4x 0/4-20 mA output + 4x digital output	150 mm	3759311
		300 mm	3759312
		450 mm	3759313

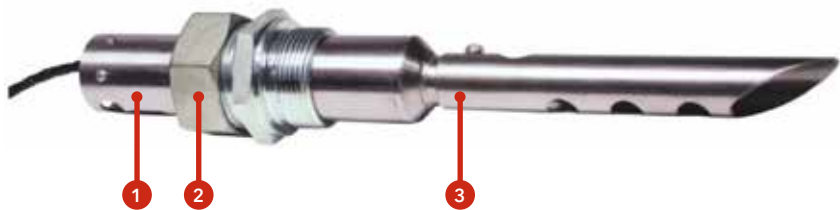

1. Lambda Probe KS1D in standard housing up to 300°C (572°F); default cable length is 2 m (6.5 ft), FEP, with connecting plug
2. Probe installation fitting (PIF)
3. Gas extraction device (GED)

The KS1D lambda probe is equipped with a 2 meter long connection cable that connects the sensor to the transmitter (LT3-F). It is possible to extend the connection up to a maximum distance of 10 meters (for greater lengths the conformity expires) with a ready-made cable and a probe connection box (PCB).

Description		Code
Extension for KS1D	5m ready-made cable	3759318
	PCB (probe connection box)*	3759319

The PCB is a small terminal box that is connected to the 2 meter long cable already existing on the probe. The wiring between the PCB and the transmitter must be carried out on the construction site with suitable cables and trained personnel.

*: the PCB is mandatory if the end user chooses to use his own connecting cable and not one of those proposed (max total length remains 10m)

EK EVO

MONOBLOCK BURNERS
FROM 250 TO 13500 kW
GAS, LIGHT OIL AND DUAL FUEL

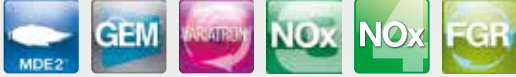

ROBUST AND WELL ENGINEERED DESIGN

The design of the EKEVO is the result of a successful synergy between ELCO key features and essential design.

EKEVO introduces a brand new aluminium body casing, enhancing the visual choice of ELCO.

Professionals will appreciate the flexibility of a 180° orientable air inlet, the compact switch box and the easy to clean glossy paint.

SMART SOLUTIONS FOR EASY MAINTENANCE

The maintenance of the EKEVO burners can comfortably be carried out thanks to a wide opening above the housing, allowing easy access to the combustion components, and thanks to the choice of the material: aluminium, lightweight to handle and resistant at the same time.

Maintenance operations are possible without disturbing the burner head and setting.

A TOTAL ADVANTAGE IN TERMS OF FLEXIBILITY AND EASE OF USE

The EKEVO are characterised by their total flexibility of installation; they have been designed to be installed in different ways: up-firing, down-firing, upside-down or side-to-side (twin chamber boilers).

All EKEVO models are fully electronically controlled and equipped with the exclusive ELCO interface allowing simple and effective communication between burner and technician.

ULTRA LOW NO_x VERSION WITH AND WITHOUT FGR SYSTEM

ELCO implements the internal and external flue gas recirculation technology to reduce pollutant emissions and satisfy even the most stringent regulations. This technology allows ELCO to guarantee emissions well below 60 mg/kWh with its EK EVO class 4 models equipped with the new Blue Triple Head, and below 30 mg/kWh with the implementation of the FGR System.

RANGE OVERVIEW



/ GAS RANGE
340 / 13500 kW

/ DUAL FUEL RANGE
250 / 10620 kW

/ LIGHT OIL RANGE
360 / 10620 kW

/ LOW NO_x / ULTRA LOW NO_x
up to 13500 kW

MAIN TECHNICAL FEATURES

- Two stage progressive/modulating forced draught burner
- Fuels:
 - natural gas, Hi = 6,99 ... 11,39 kWh/Nm³
 - LPG, Hi = 25,89 kWh/Nm³
 - light oil, viscosity 6 mm²/s at 20°C, Hi = 11,86 kWh/kg
- Combustion technology:
 - Low NOx class 4 (≤60 mg/kWh), class 3 (≤80 mg/kWh) and class 2 (≤120 mg/kWh) in gas operation, according to EN676
 - Low NOx class 3 (≤120 mg/kWh) and class 2 (≤185 mg/kWh) in light oil operation, according to EN267
 - Models equipped with FGR System to reach NOx emission values below 30 mg/kWh
- Integrated switch cabinet (ISC System) with modular concept complete for an easy installation with:
 - BT300 control box
 - fan motor direct start-up
 - enumerated connection terminals
 - three-phase electrical power supply
 - available as options: power regulator, speed controller, O₂/CO regulator and BUS interface
- Innovative design allowing easy access to burner components for fast start-up and reduced maintenance time and space
- Orientable air intake box
- Secured burner head adjustments during maintenance (RTC System)
- Closing of the air damper on burner shut-down
- Multiple gas train matching according to the inlet gas pressure
- Gas train factory assembled and tested for tightness and electrical security
- Products are in compliance with EN676 and EN267 European standards and with the following directives:
 - 2014/35/UE Low Voltage Directive
 - 2014/30/UE EMC Directive
 - 2016/426/UE Gas Appliances Regulation
 - 2006/42/EC Machinery Directive
 - 2011/65/EU RoHS2 Directive

PRODUCT LIST



EKEVO 7 G-EFX / EKEVO 8 G-EFX

440 ... 6610 kW

Two stage progressive/modulating electronic

NOx
<50
mg/kWh



- **Fuels:** natural gas, Hi = 6,99 ... 11,39 kWh/Nm³;
LPG, Hi = 25,89 kWh/Nm³
- **Emission class:** Low NOx class 4 (≤60 mg/kWh) according to EN676
- **Protection level:** IP 41

TECHNICAL DATA

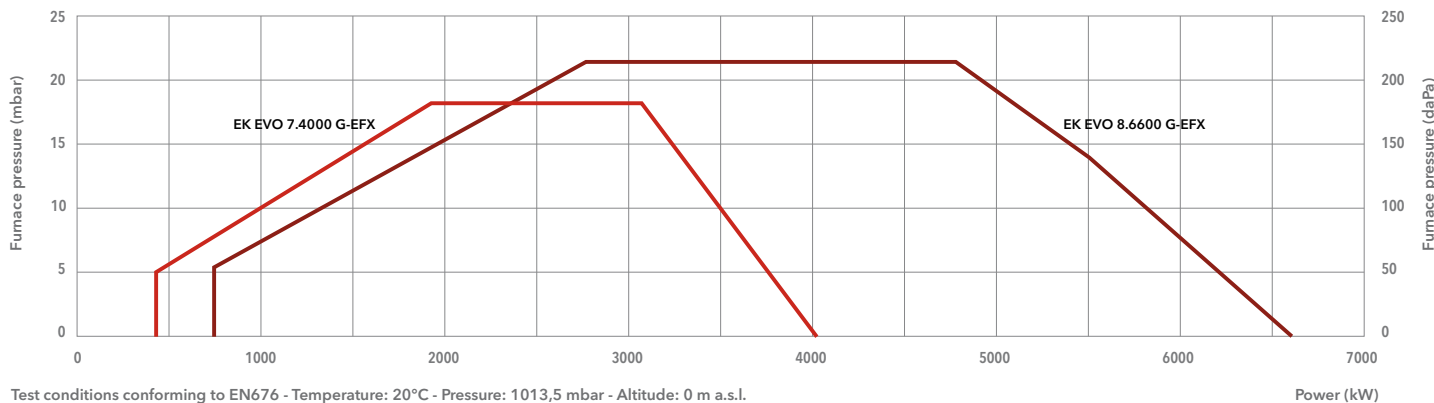

Test conditions conforming to EN676 - Temperature: 20°C - Pressure: 1013,5 mbar - Altitude: 0 m a.s.l.

	EK EVO 7.4000 G-EFX	EK EVO 8.6600 G-EFX
Operating range	440 – 4040 kW	730 – 6610 kW
Gas pressure	100 – 500 mbar (100 – 360 mbar for d705)	135 – 500 mbar
Gas connection	DN65	DN100
Control box / flame detector	BT300 / KLC	BT300 / KLC
Auxiliary voltage	1NPE AC 230 V – 50 Hz TN-S	1NPE AC 230 V – 50 Hz TN-S
Power supply	3PE AC 400 V – 50 Hz	3PE AC 400 V – 50 Hz
Fan motor	50 Hz – 7,5 kW	50 Hz – 15 kW
Acoustic level	<80,6 dB(A)	<87,6 dB(A)
CE certificate	0085CL0215	0085CL0215
Burner codes (body + head)	KN	3759493
	KM	3759494
	KL	3759495
		3759813
		3759814
		3759815

GAS TRAINS

DUNGS

Models for EK EVO 7	Code
GT-d705-2" (*)	3759628
GT-d701-65	3759625
GT-d702-80	3759626
GT-d703-100	3759627

Models for EK EVO 8	Code
GT-d901-65	3759630
GT-d902-80	3759631
GT-d903-100	3759632

SIEMENS

Model for EK EVO 7	Code
GT-s705-2"	3759284
GT-s701-65	3759280
GT-s702-80	3759281
GT-s703-100	3759282
GT-s704-125	3759283

Models for EK EVO 8	Code
GT-s901-65	3759286
GT-s902-80	3759287
GT-s903-100	3759288
GT-s904-125	3759289

FILTERS

Model	Code
FG-Rp2"	3757200
FG-DN65	3757198
FG-DN80	3757201
FG-DN100	3757195
FG-DN125	3757209

*: integrated filter

i Pressure drops graphs:
see following pages
**Dimensions of gas trains
and gas filters:** see page 308



DIMENSIONS (mm)

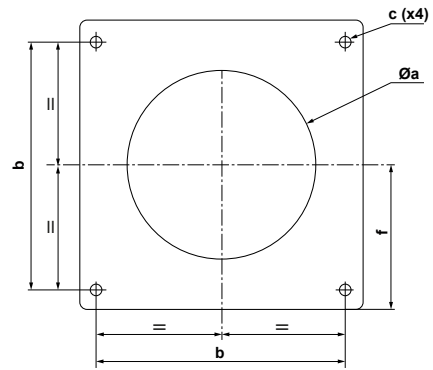
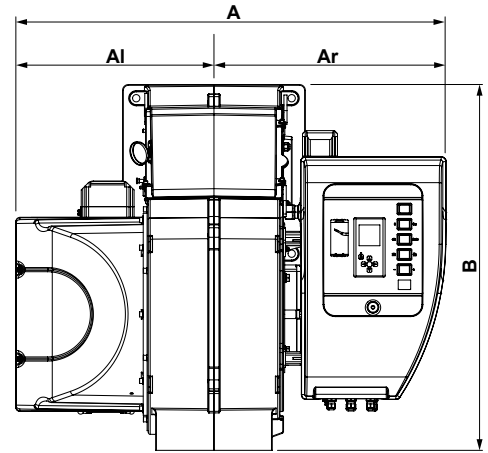
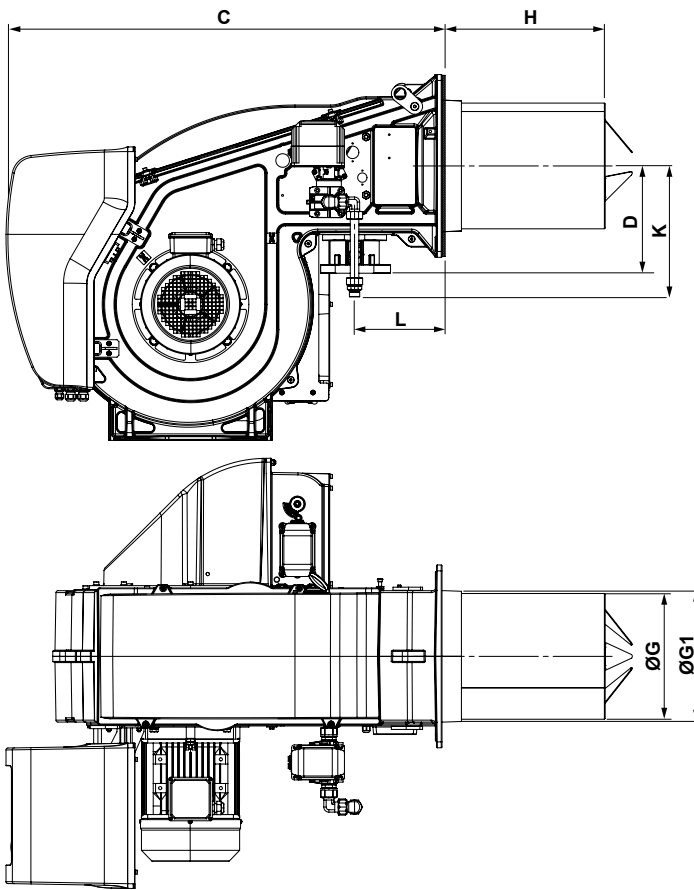

Model	A	Al	Ar	B	C	D	E	ØG	ØG1	H			K	L	Øa	b	c	f
										KN	KM	KL						
EK EVO 7.4000	1107	510	597	941	1130	276	235	325	338	420	550	680	320	233	360-400	400	M16	235
EK EVO 8.6600	1323	670	653	1231	1352	307	293	369	376	575	725	875	377*/366**	230	380-410	505	M20	293

*: applies to gas connectors DN100/65 and DN100/85

** : applies to gas connectors DN100/100 and DN100/125

PACKAGING

The burner is delivered on a pallet with:

- burner body with mounted combustion head
- gas train and filter
- boiler fixing accessories
- technical documentation

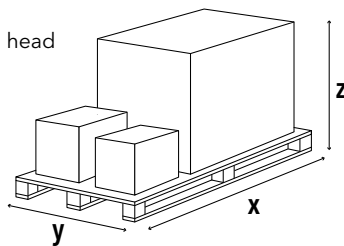

Model	Dimensions (mm)			Gross weight (kg)
	X	Y	Z	
EK EVO 7.4000	2046	1414	1233	350
EK EVO 8.6600	2300	1500	1573	580

EKEVO 7 G-EFX / EKEVO 8 G-EFX

440 ... 6610 kW

Two stage progressive/modulating electronic

PRESSURE LOSS [BURNER HEAD + GAS TRAIN] (mbar)

EKEVO 7.4000 G-EFX

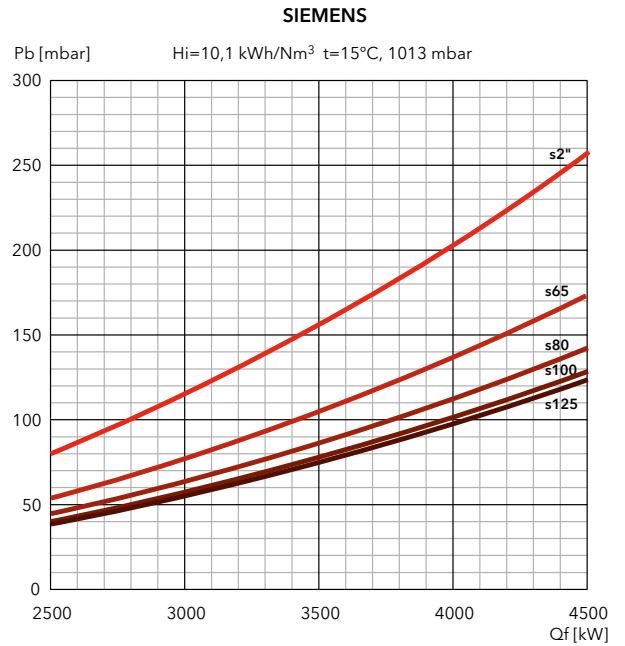
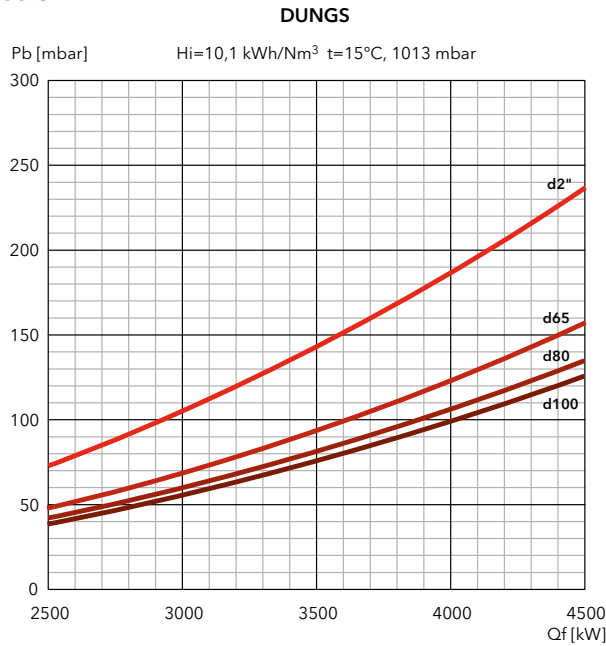

FILTERS

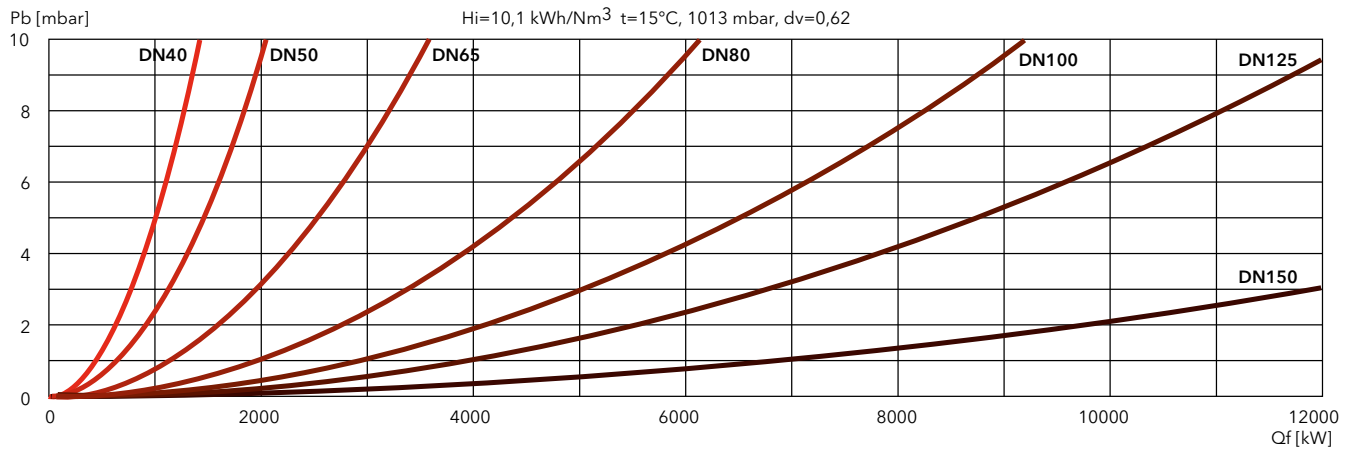



PRESSURE LOSS [BURNER HEAD + GAS TRAIN] (mbar)

EK EVO 8.6600 G-EFX

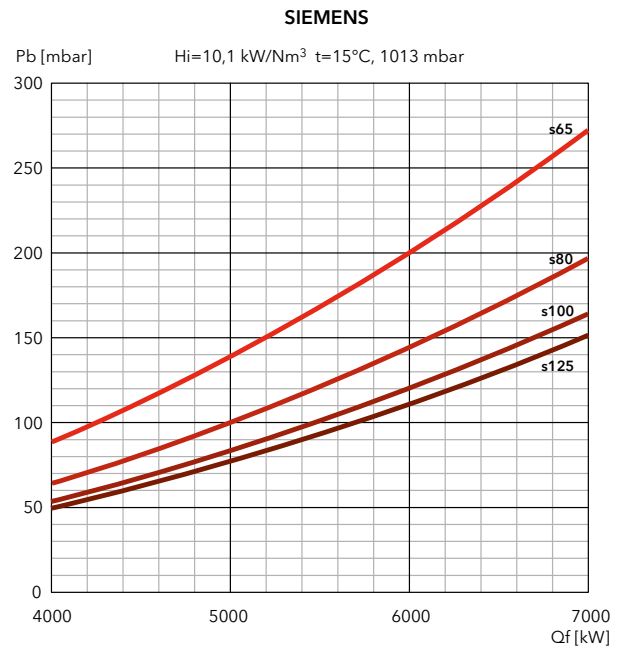
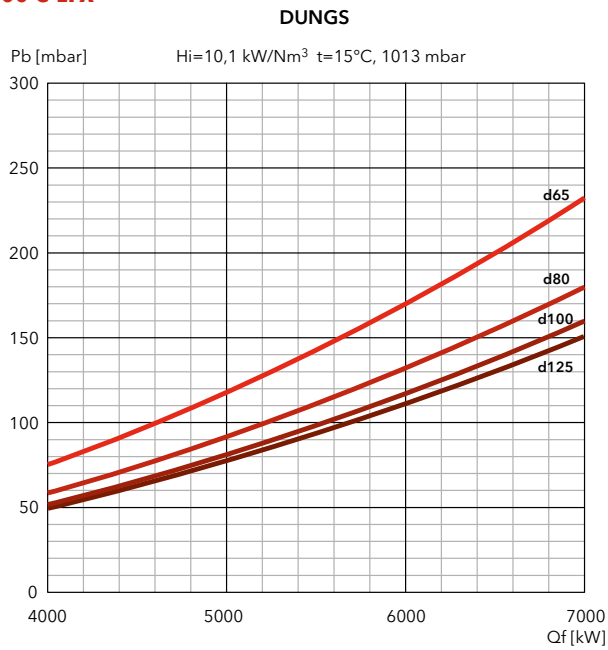

FILTERS

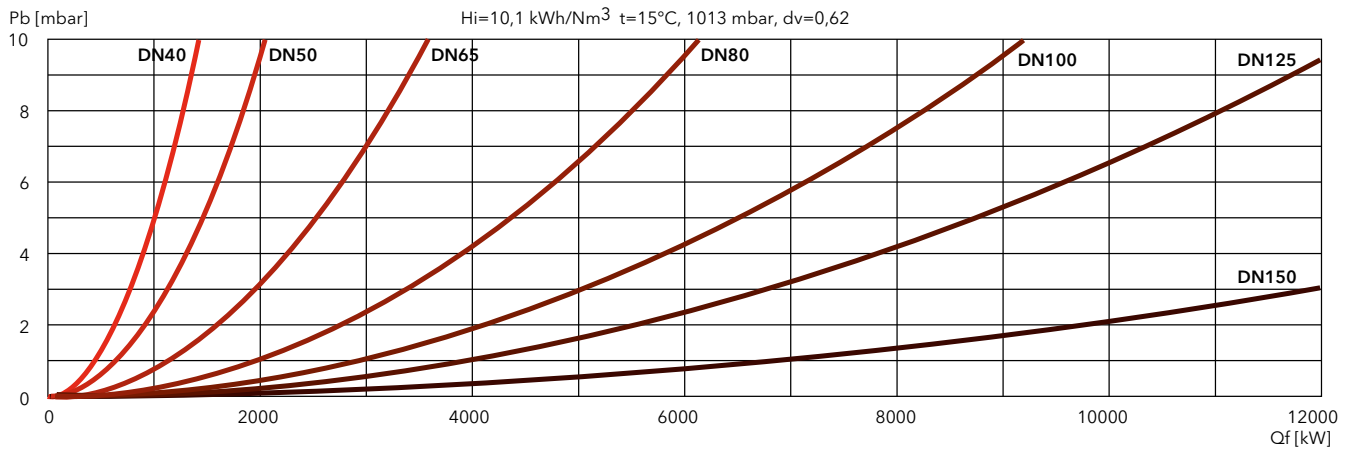

EKEVO 9 G-EFX

890 ... 11350 kW

Two stage progressive/modulating electronic

NO_x
<50
mg/kWh

- **Fuels:** natural gas, Hi = 6,99 ... 11,39 kWh/Nm³;
LPG, Hi = 25,89 kWh/Nm³
- **Emission class:** Low NO_x class 4 (≤60 mg/kWh) according to EN676
- **Protection level:** IP 41

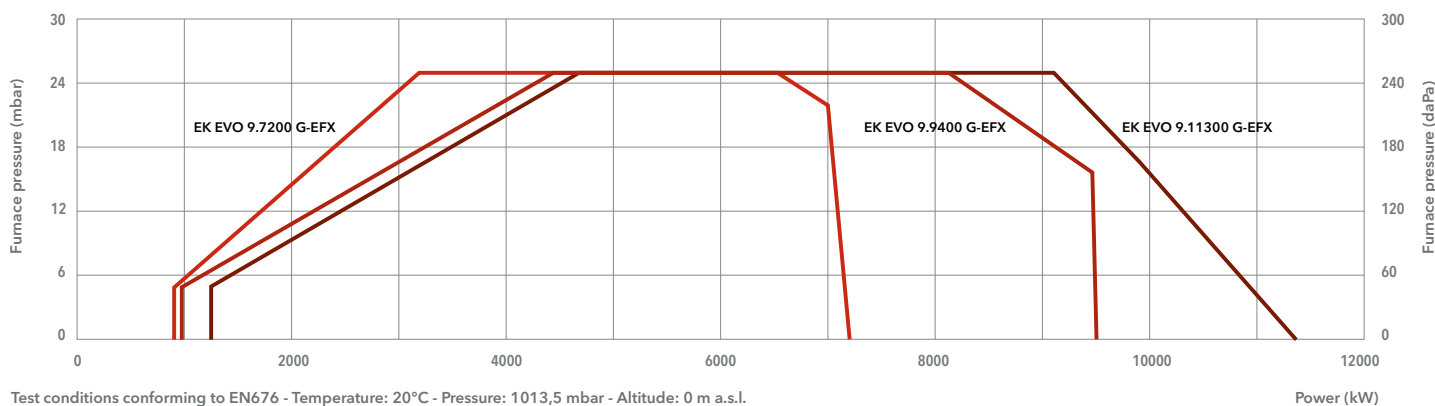
TECHNICAL DATA

	EK EVO 9.7200 G-EFX	EK EVO 9.9400 G-EFX	EK EVO 9.11300 G-EFX
Operating range	890 - 7200 kW	980 - 9440 kW	1250 - 11350 kW
Gas pressure	150 - 500 mbar	175 - 500 mbar	155 - 500 mbar
Gas connection	DN100	DN100	DN100
Control box / flame detector	BT300 / KLC	BT300 / KLC	BT300 / KLC
Auxiliary voltage	1NPE AC 230 V - 50 Hz TN-S	1NPE AC 230 V - 50 Hz TN-S	1NPE AC 230 V - 50 Hz TN-S
Power supply	3PE AC 400 V - 50 Hz	3PE AC 400 V - 50 Hz	3PE AC 400 V - 50 Hz
Fan motor	50 Hz - 22 kW	50 Hz - 22 kW	50 Hz - 37 kW
Acoustic level	<84,4 dB(A)	<87,2 dB(A)	<88,6 dB(A)
CE certificate	0085CL0215	0085CL0215	0085CL0215
Burner codes (body + head)	KN	3760498	3761544
	KM	3760499	3761545
	KL	3760500	3761546

GAS TRAINS**DUNGS**

Model	Code
GT-d901-65	3759630
GT-d902-80	3759631
GT-d903-100	3759632

SIEMENS

Model	Code
GT-s901-65	3759286
GT-s902-80	3759287
GT-s903-100	3759288
GT-s904-125	3759289

FILTERS

Model	Code
FG-DN65	3757198
FG-DN80	3757201
FG-DN100	3757195
FG-DN125	3757209

i **Pressure drops graphs:** see following pages
Dimensions of gas trains and gas filters: see page 309



DIMENSIONS (mm)

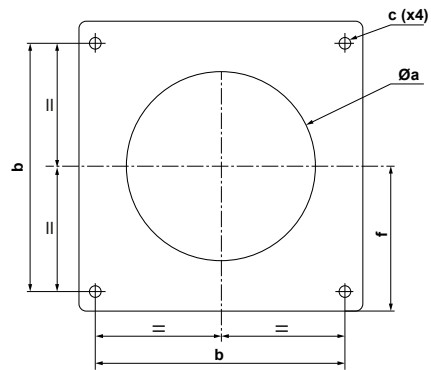
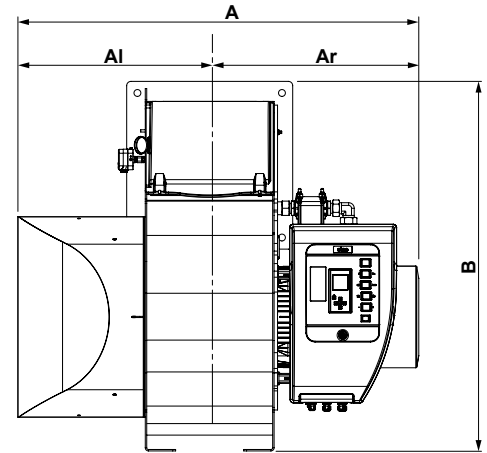
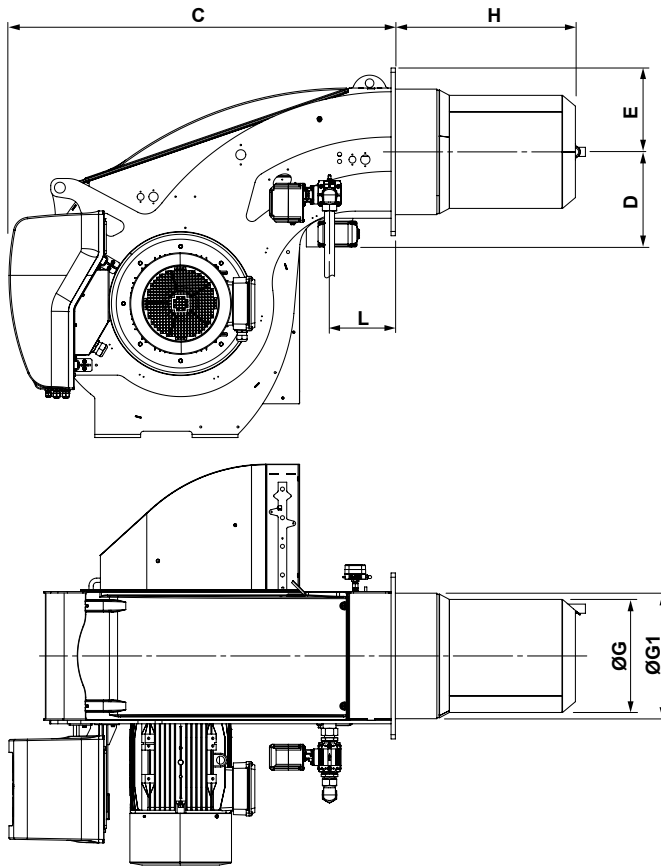

Model	A	Al	Ar	B	C	D	E	ØG	ØG1	H			L	Øa	b	c	f
										KN	KM	KL					
EK EVO 9.7200	1400	670	730	1291	1350	332	293	385	438,5	649	799	949	230	460-480	505	M20	293
EK EVO 9.9400	1400	670	730	1291	1350	332	293	395	438,5	629	779	929	230	460-480	505	M20	293
EK EVO 9.11300	1462	674	788	1291	1350	332	293	395	438,5	629	779	929	230	460-480	505	M20	293

PACKAGING

The burner is delivered on a pallet with:

- burner body with mounted combustion head
- gas train and filter
- boiler fixing accessories
- technical documentation

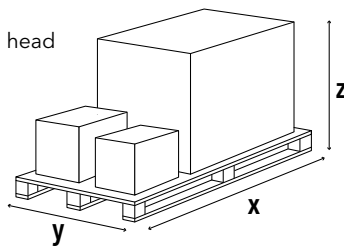

Model	Dimensions (mm)			Gross weight (kg)
	X	Y	Z	
EK EVO 9.7200	2300	1500	1573	580
EK EVO 9.9400	2300	1500	1573	700
EK EVO 9.11300	2300	1500	1573	700

EKEVO 9 G-EFX

890 ... 11350 kW

Two stage progressive/modulating electronic

PRESSURE LOSS [BURNER HEAD + GAS TRAIN] (mbar)

EK EVO 9.7200 G-EFX

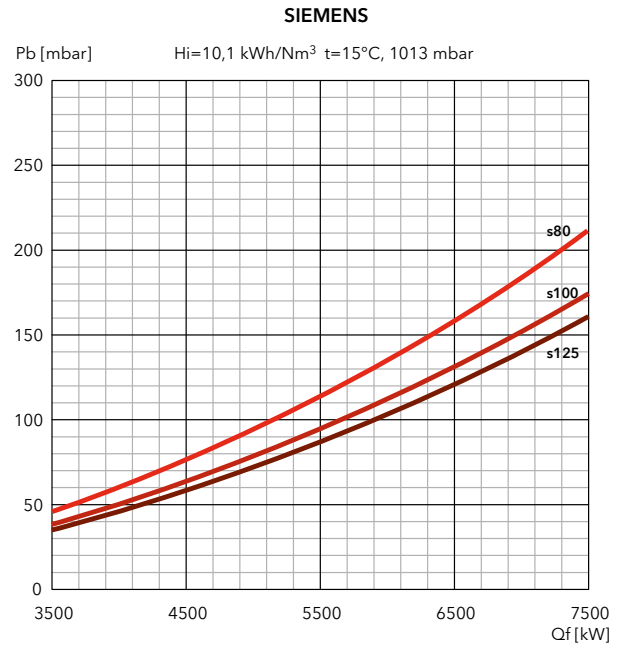
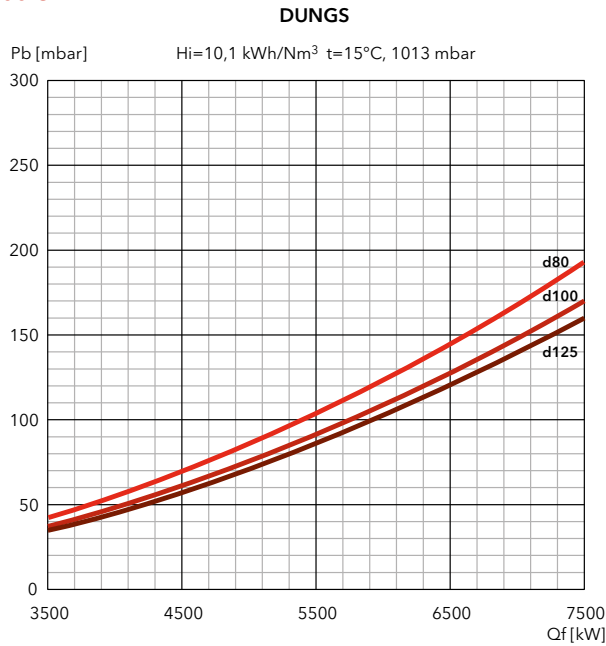

EK EVO 9.9400 G-EFX

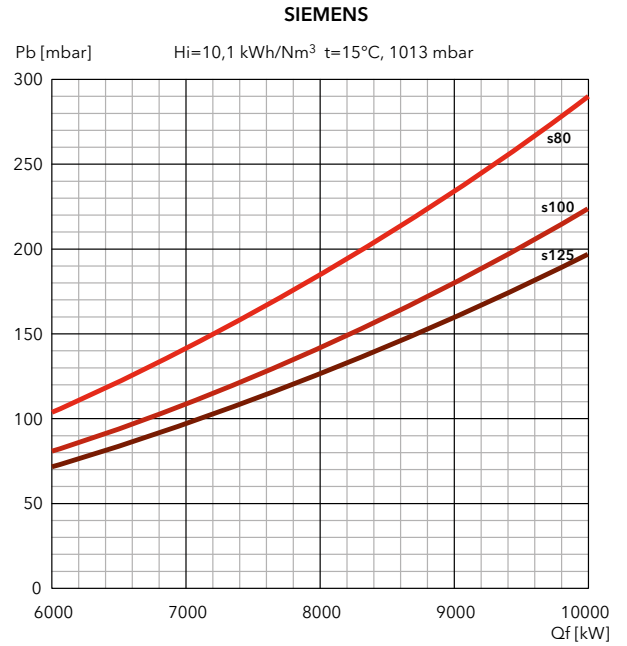
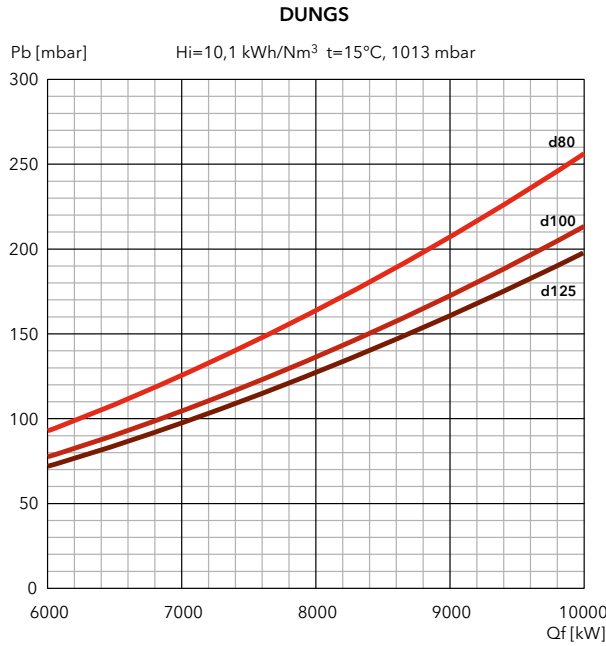

FILTERS

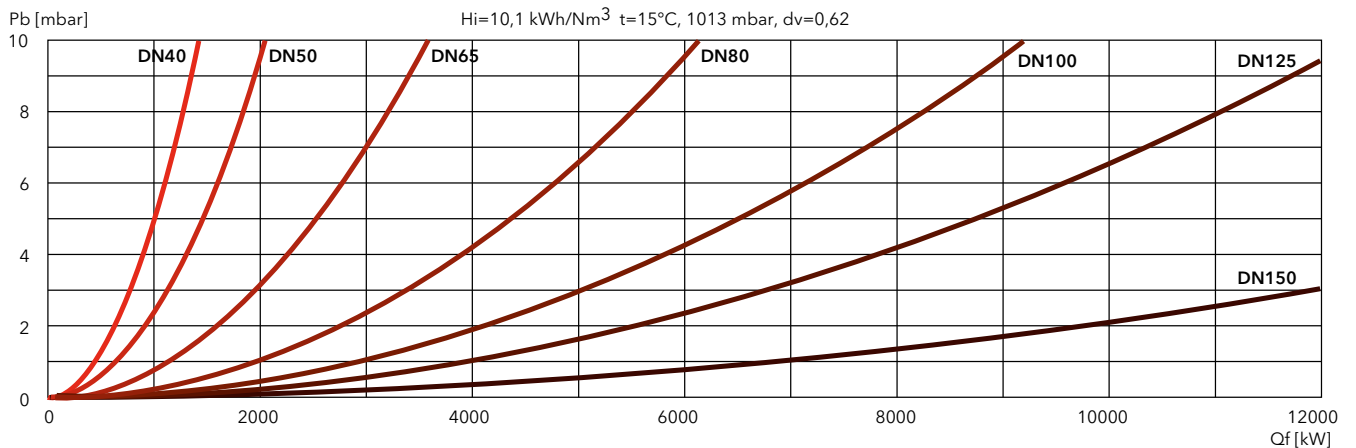



PRESSURE LOSS [BURNER HEAD + GAS TRAIN] (mbar)

EK EVO 9.11300 G-EFX

DUNGS

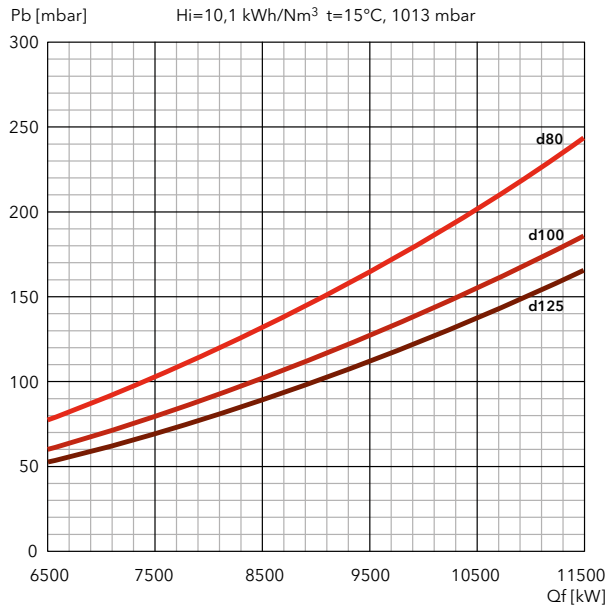

SIEMENS

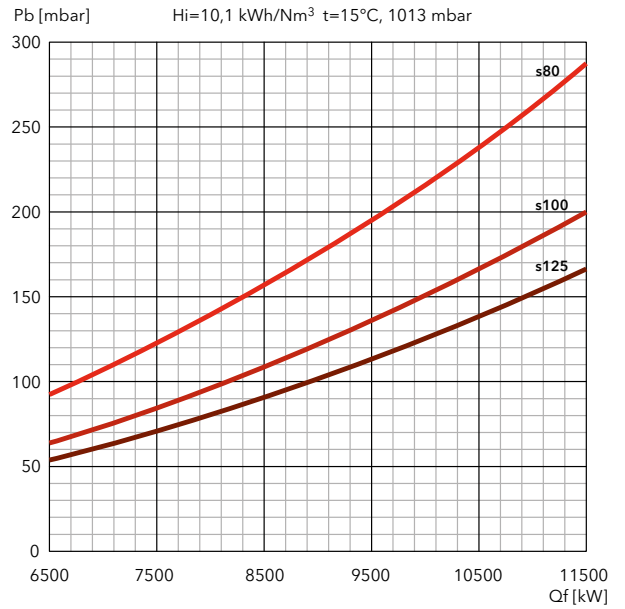

FILTERS

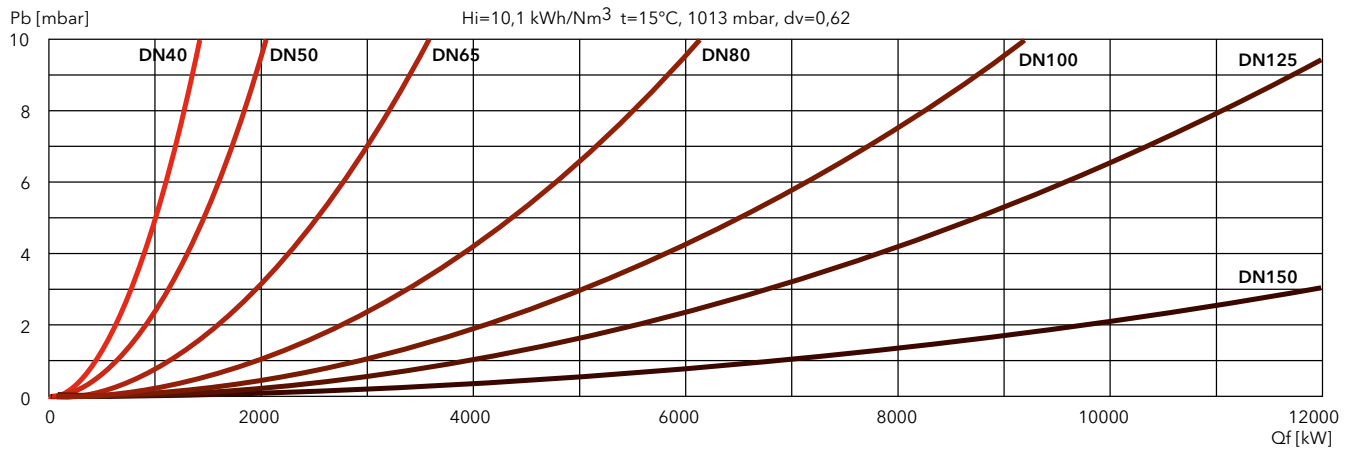

EKEVO 6 G-EF3

340 ... 2900 kW

Two stage progressive/modulating electronic



- **Fuels:** natural gas, Hi = 6,99 ... 11,39 kWh/Nm³;
LPG, Hi = 25,89 kWh/Nm³
- **Emission class:** Low NOx class 3 (≤80 mg/kWh) according to EN676
- **Protection level:** IP 41

TECHNICAL DATA

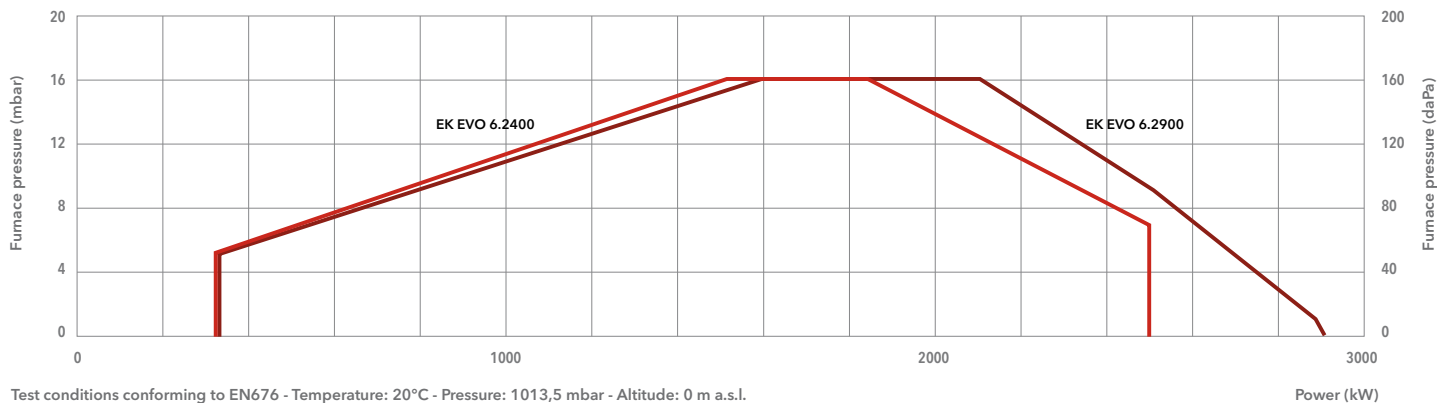

Test conditions conforming to EN676 - Temperature: 20°C - Pressure: 1013,5 mbar - Altitude: 0 m a.s.l.

	EK EVO 6.2400 G-EF3	EK EVO 6.2900 G-EF3
Operating range	340 – 2500 kW	340 – 2900 kW
Gas pressure	50 – 500 mbar (50 – 360 mbar for d452 and d453)	50 – 500 mbar (50 – 360 mbar for d452 and d453)
Gas connection	DN65	DN65
Control box / flame detector	BT300 / QRA2	BT300 / QRA2
Auxiliary voltage	1NPE AC 230 V – 50 Hz TN-S	1NPE AC 230 V – 50 Hz TN-S
Power supply	3PE AC 400 V – 50 Hz	3PE AC 400 V – 50 Hz
Fan motor	50 Hz – 3 kW	50 Hz – 4 kW
Acoustic level	<74 dB(A)	<77 dB(A)
CE certificate	0085CL0215	0085CL0215
Burner codes (body + head)	KN	3754046
	KM	3754050
	KL	3754054
		3754055

GAS TRAINS

DUNGS

Model	Code
GT-d452-1"1/2 (*)	3750510
GT-d453-2" (*)	3750511
GT-d454-65	3750512
GT-d455-80	3750513

*: integrated filter

SIEMENS

Model	Code
GT-s451-1"1/2	3750525
GT-s452-2"	3750526
GT-s453-65	3750527
GT-s454-80	3750528
GT-s455-100	3750529

FILTERS

Model	Code
FG-Rp1"1/2	3757199
FG-Rp2"	3757200
FG-DN65	3757198
FG-DN80	3757201
FG-DN100	3757195

i Pressure drops graphs: see following pages
 Dimensions of gas trains and gas filters: see page 310



DIMENSIONS (mm)

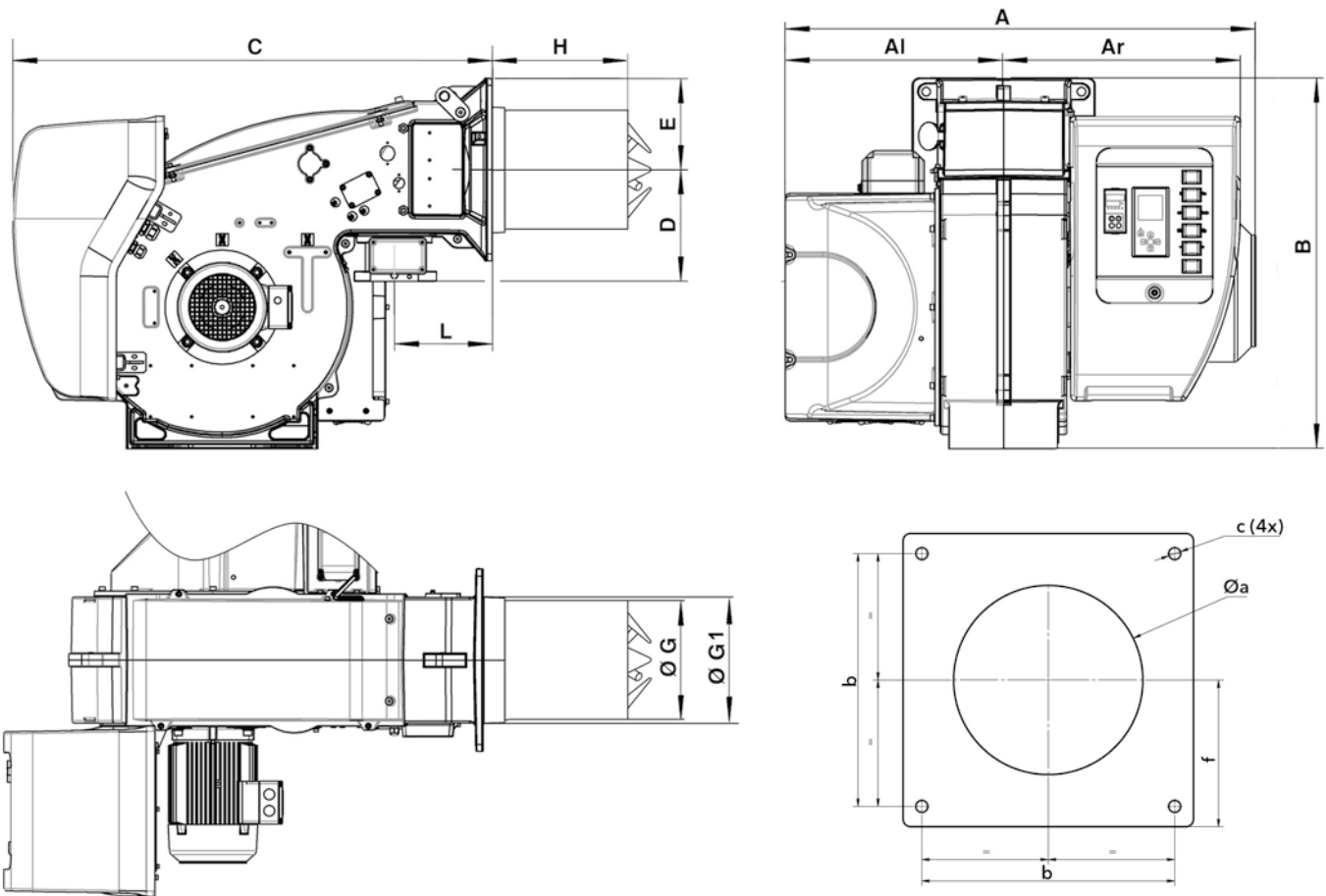

Model	A	Al	Ar	B	C	D	E	ØG	ØG1	H			L	Øa	b	c	f
										KN	KM	KL					
EK EVO 6... G-EF3	1035	509	556	812	1046	245	200	263	277	400	520	640	215	300-340	340	M16	200

PACKAGING

The burner is delivered on a pallet with:

- burner body with mounted combustion head
- gas train and filter
- boiler fixing accessories
- technical documentation

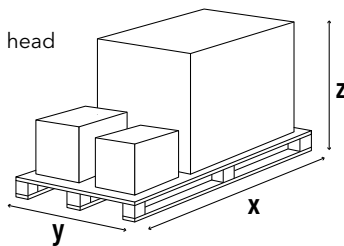

Model	Dimensions (mm)			Gross weight (kg)
	X	Y	Z	
EK EVO 6.2400 G-EF3	2046	1414	1233	300
EK EVO 6.2900 G-EF3	2046	1414	1233	300

EKEVO 6 G-EF3

340 ... 2900 kW

Two stage progressive/modulating electronic

PRESSURE LOSS [BURNER HEAD + GAS TRAIN] (mbar)

EK EVO 6.2400 G-EF3

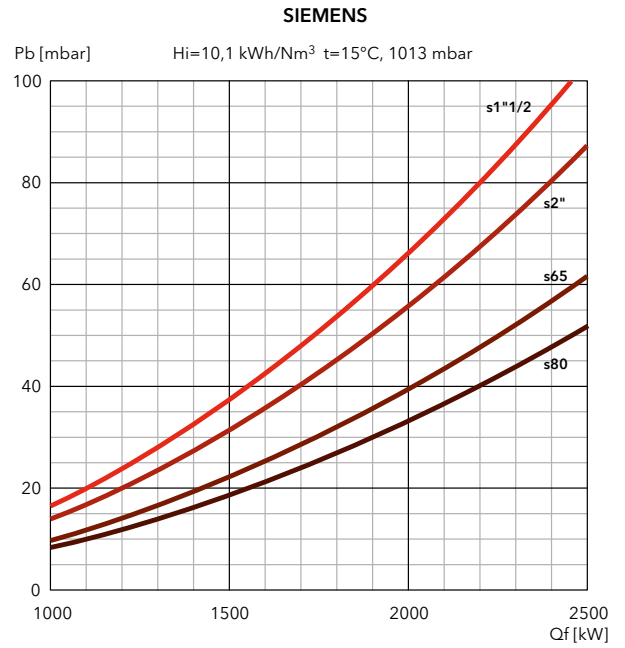
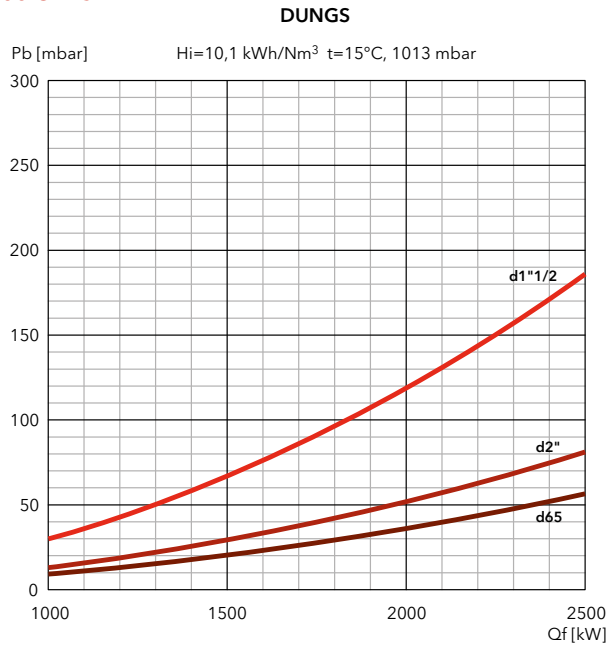

FILTERS

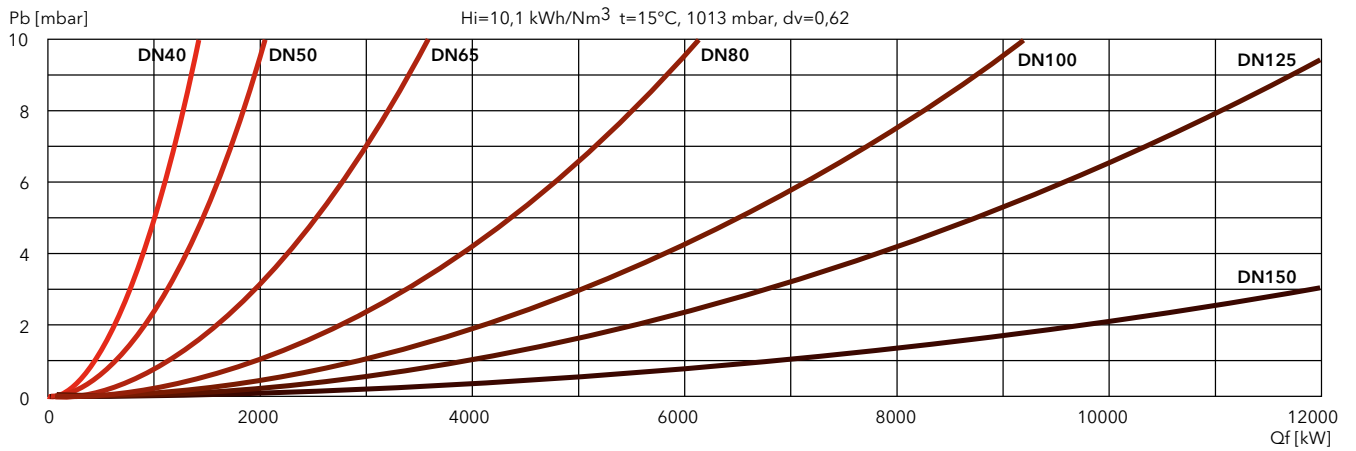



PRESSURE LOSS [BURNER HEAD + GAS TRAIN] (mbar)

EK EVO 6.2900 G-EF3

DUNGS

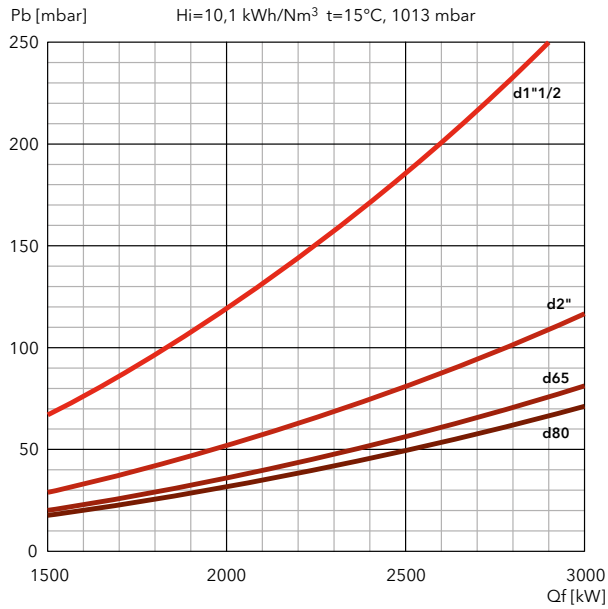

SIEMENS

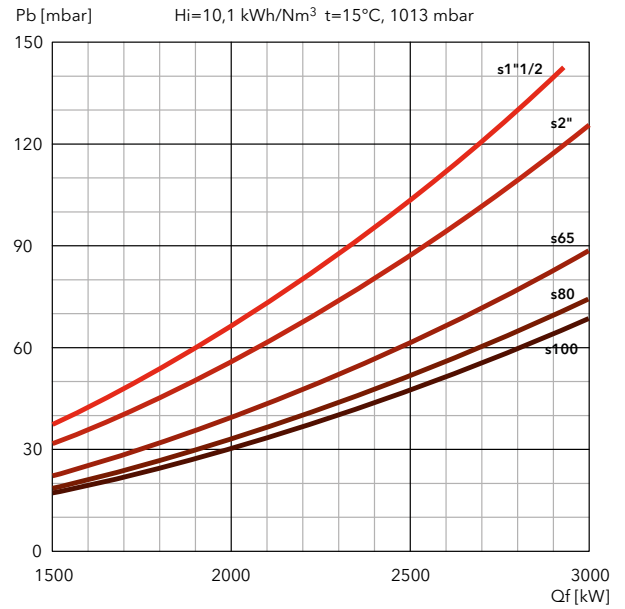

FILTERS

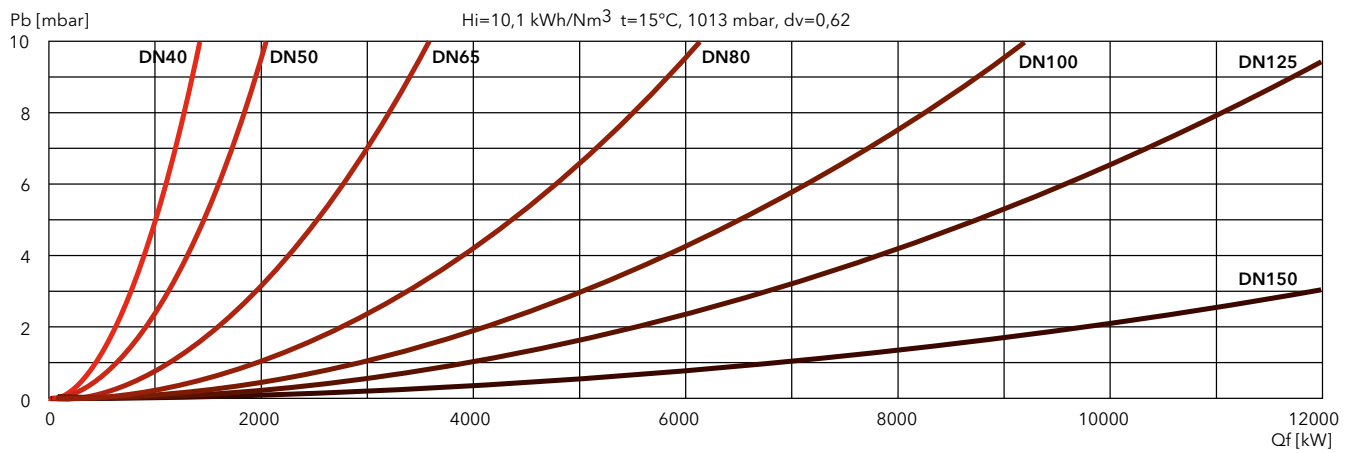

EKEVO 7 G-EF3

470 ... 5500 kW

Two stage progressive/modulating electronic



- **Fuels:** natural gas, Hi = 6,99 ... 11,39 kWh/Nm³;
LPG, Hi = 25,89 kWh/Nm³
- **Emission class:** Low NOx class 3 (≤80 mg/kWh) according to EN676
- **Protection level:** IP 41

TECHNICAL DATA

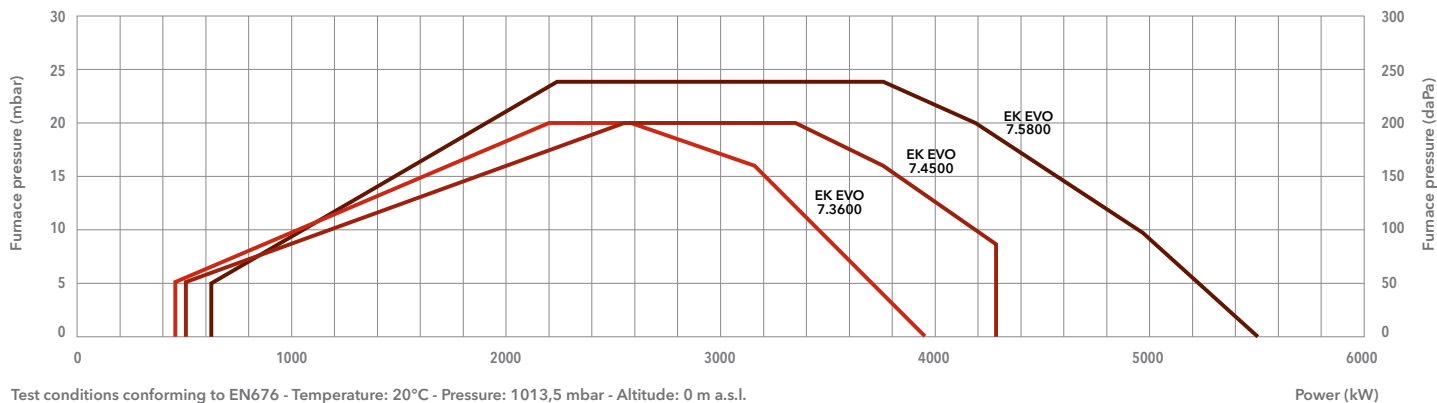

Test conditions conforming to EN676 - Temperature: 20°C - Pressure: 1013,5 mbar - Altitude: 0 m a.s.l.

	EK EVO 7.3600 G-EF3	EK EVO 7.4500 G-EF3	EK EVO 7.5800 G-EF3
Operating range	470 – 3980 kW	510 – 4290 kW	620 – 5500 kW
Gas pressure	50 – 500 mbar (50 – 360 mbar for d452 and d453)		
Gas connection	DN65	DN65	DN65
Control box / flame detector	BT300 / QRA2	BT300 / QRA2	BT300 / QRA2
Auxiliary voltage	1NPE AC 230 V – 50 Hz TN-S	1NPE AC 230 V – 50 Hz TN-S	1NPE AC 230 V – 50 Hz
Power supply	3PE AC 400 V – 50 Hz	3PE AC 400 V – 50 Hz	3PE AC 400 V – 50 Hz
Fan motor	50 Hz – 7,5 kW	50 Hz – 7,5 kW	50 Hz – 11 kW
Acoustic level	<83 dB(A)	<81 dB(A)	<85 dB(A)
CE certificate	0085CL0215	0085CL0215	0085CL0215
Burner codes (body + head)	KN	3754048	3756103
	KM	3754052	3756104
	KL	3754056	3756105

GAS TRAINS

DUNGS

Model	Code
GT-d452-1"1/2 (*)	3750510
GT-d453-2" (*)	3750511
GT-d454-65	3750512
GT-d455-80	3750513
GT-d456-100	3750514

SIEMENS

Model	Code
GT-s451-1"1/2	3750525
GT-s452-2"	3750526
GT-s453-65	3750527
GT-s454-80	3750528
GT-s455-100	3750529
GT-s456-125	3750530

FILTERS

Model	Code
FG-Rp1"1/2	3757199
FG-Rp2"	3757200
FG-DN65	3757198
FG-DN80	3757201
FG-DN100	3757195
FG-DN125	3757209

*: integrated filter

i **Pressure drops graphs:** see following pages
Dimensions of gas trains and gas filters: see page 310



DIMENSIONS (mm)

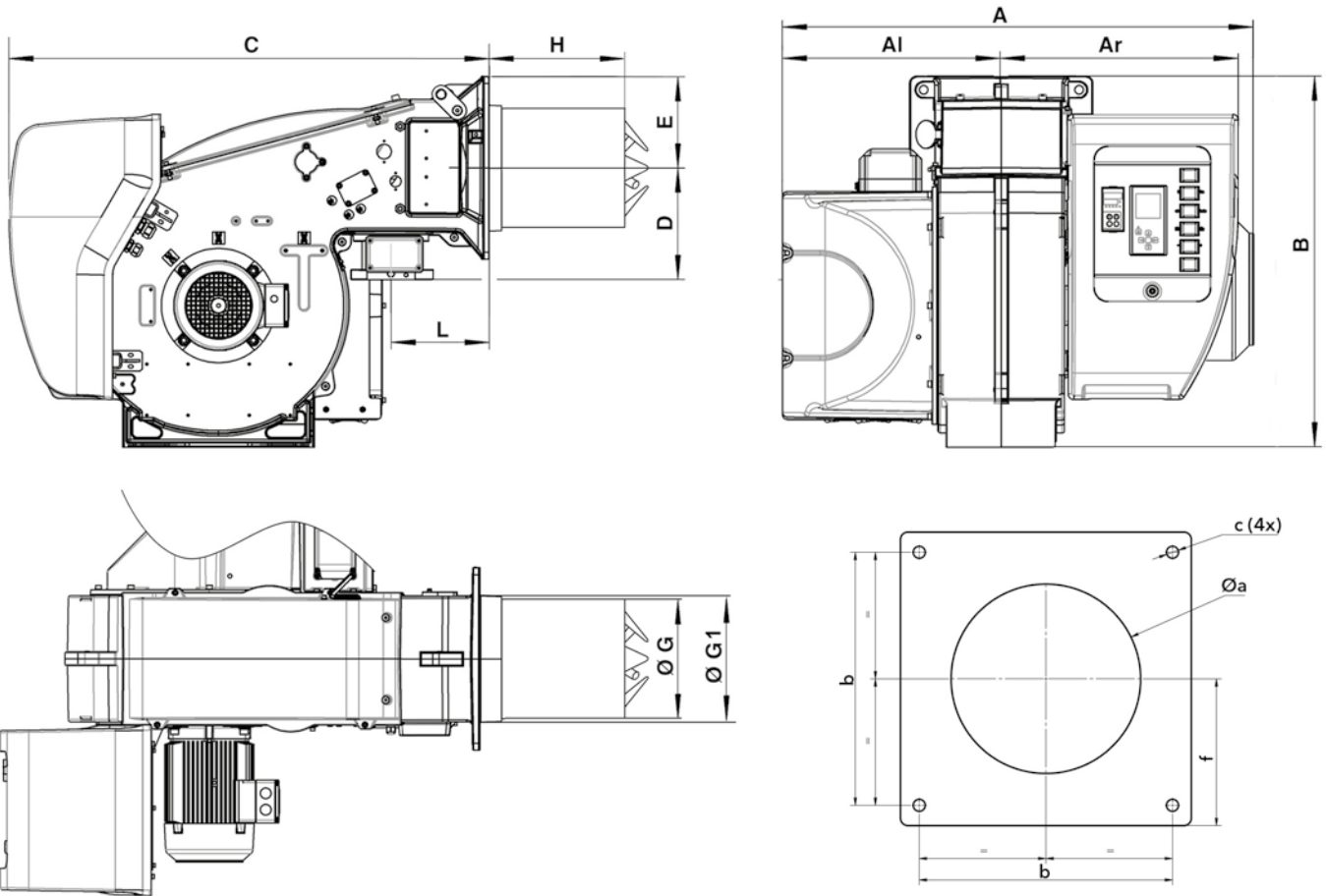

Model	A	Al	Ar	B	C	D	E	ØG	ØG1	H			L	Øa	b	c	f
										KN	KM	KL					
EK EVO 7.3600/4500	1096	509	587	941	1120	276	235	323,5	338,5	420	550	680	225	360-400	400	M16	235
EK EVO 7.5800	1205	510	695	941	1171	276	235	323,5	338,5	420	550	680	225	360-400	400	M16	235

PACKAGING

The burner is delivered on a pallet with:

- burner body with mounted combustion head
- gas train and filter
- boiler fixing accessories
- technical documentation

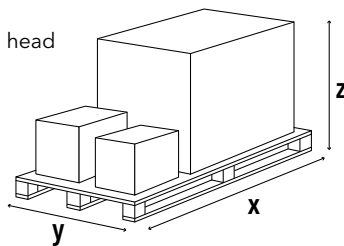

Model	Dimensions (mm)			Gross weight (kg)
	X	Y	Z	
EK EVO 7.3600 G-EF3	2046	1414	1233	350
EK EVO 7.4500 G-EF3	2046	1414	1233	350
EK EVO 7.5800 G-EF3	2046	1414	1233	350

EKEVO 7 G-EF3

470 ... 5500 kW

Two stage progressive/modulating electronic

PRESSURE LOSS [BURNER HEAD + GAS TRAIN] (mbar)

EK EVO 7.3600 G-EF3

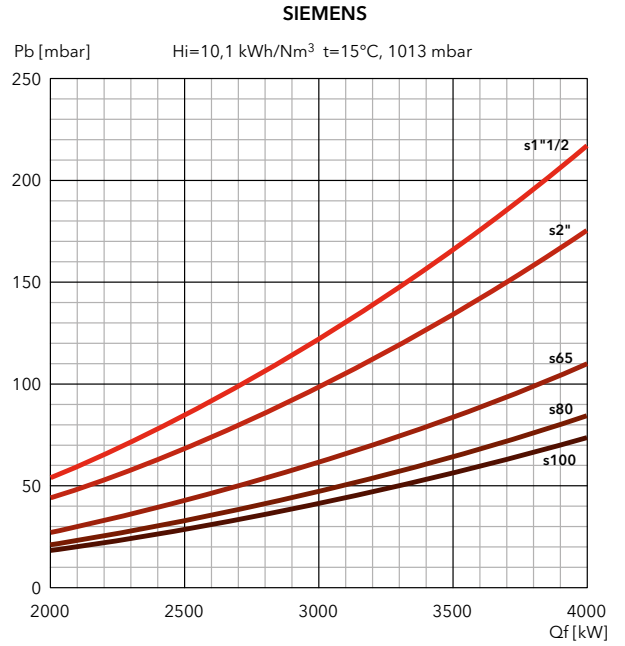
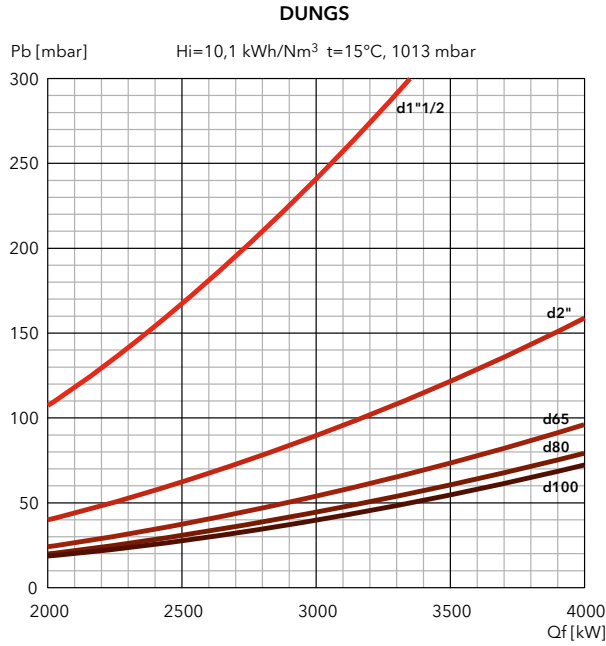

EK EVO 7.4500 G-EF3

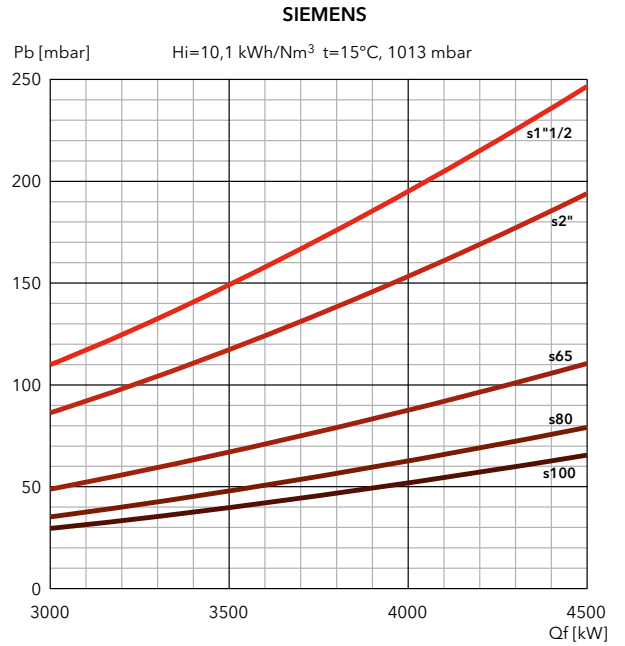
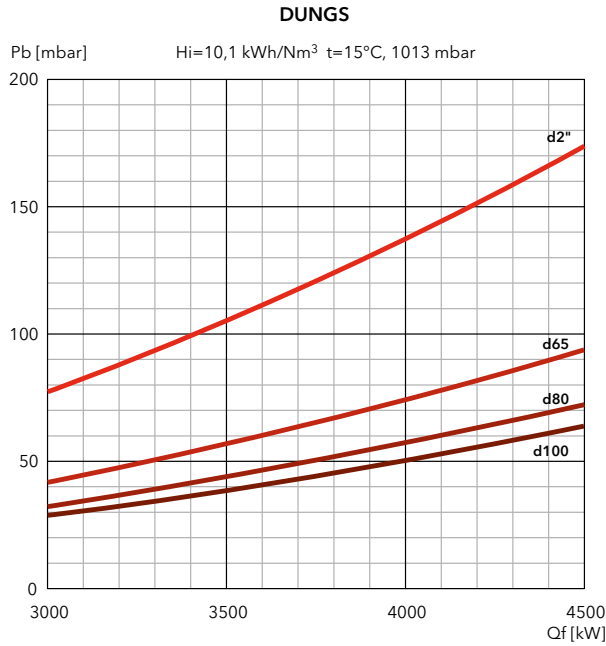

FILTERS

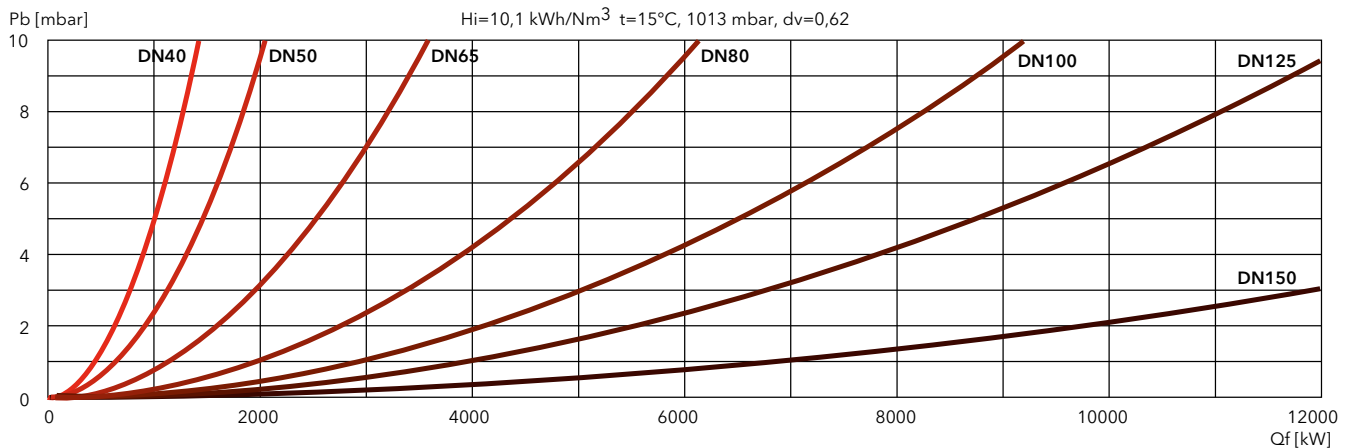



PRESSURE LOSS [BURNER HEAD + GAS TRAIN] (mbar)

EK EVO 7.5800 G-EF3

DUNGS

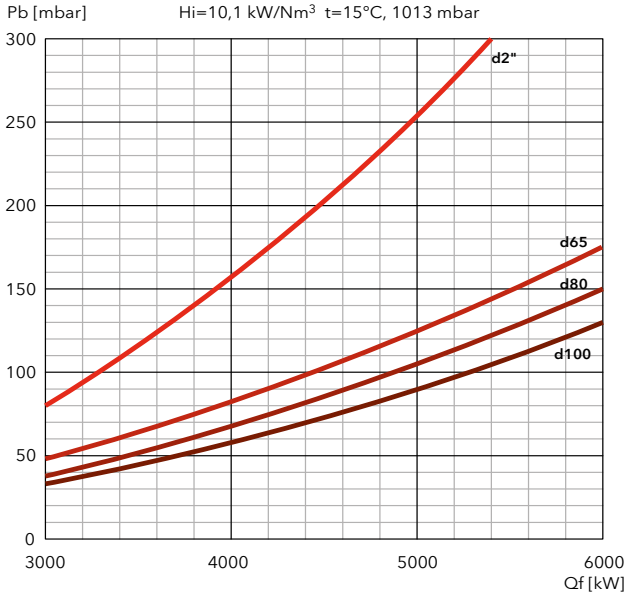

SIEMENS

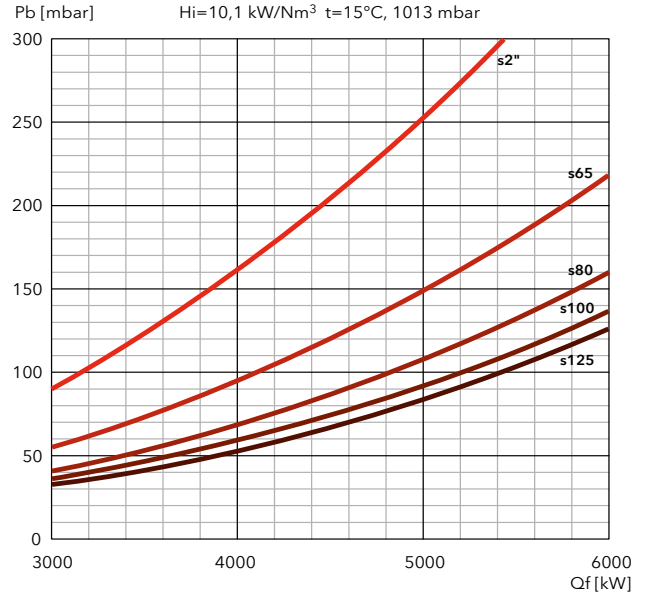

FILTERS

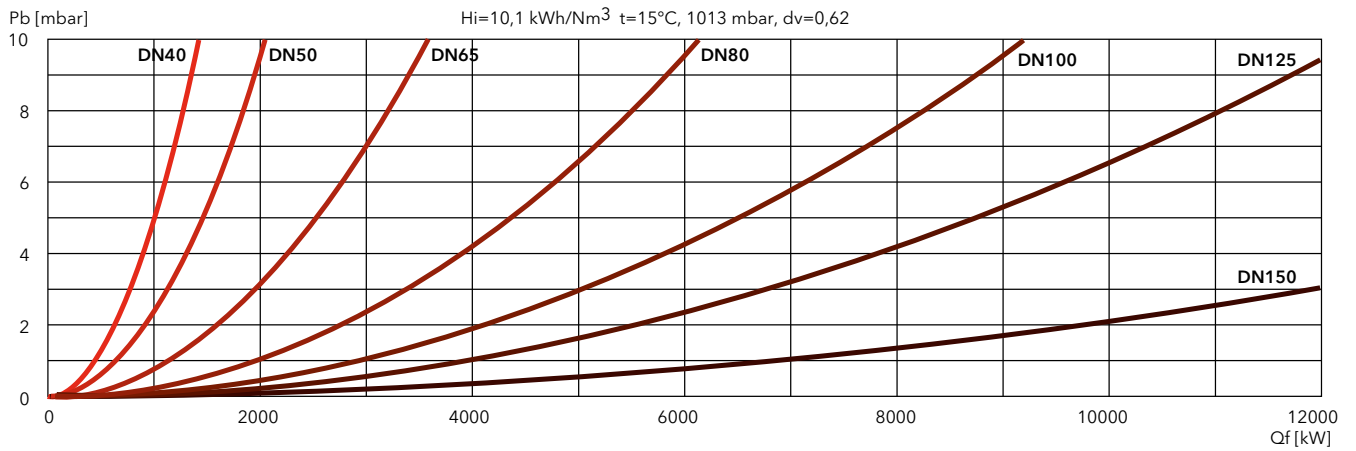

EKEVO 7 G-EU3

610 ... 7450 kW

Two stage progressive/modulating electronic



- **Fuels:** natural gas, Hi = 6,99 ... 11,39 kWh/Nm³;
LPG, Hi = 25,89 kWh/Nm³
- **Emission class:** Low NOx class 3 (≤80 mg/kWh) according to EN676
- **Additional configuration:** models with FGR System (≤30 mg/kWh) available on request
- **Protection level:** IP 41

TECHNICAL DATA

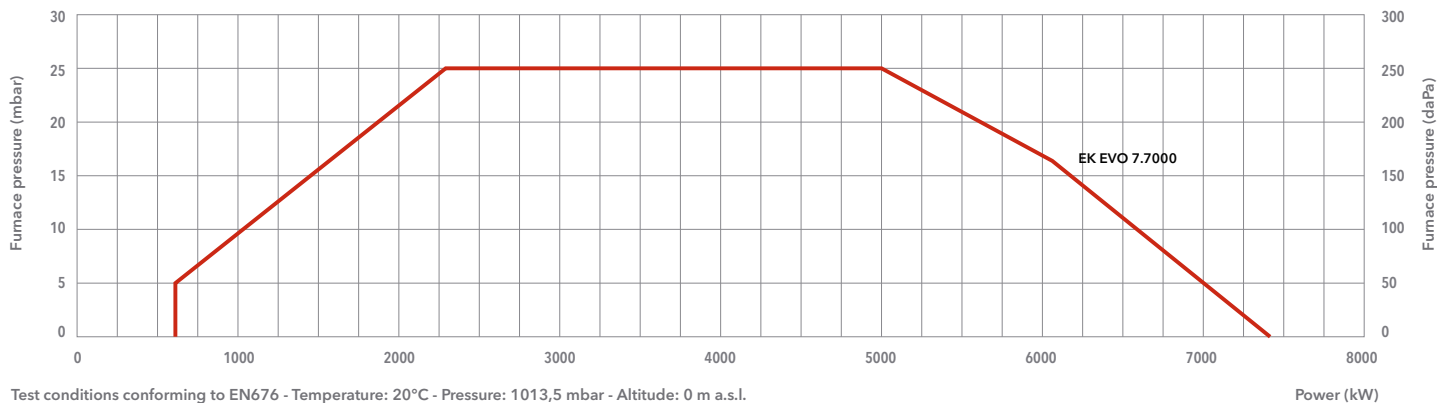

		EKEVO 7.7000 G-EU3
Operating range		610 - 7450 kW
Gas pressure		105 - 500 mbar (105 - 360 mbar for d452 and d453)
Gas connection		DN65
Control box / flame detector		BT300 / KLC
Auxiliary voltage		1NPE AC 230 V - 50 Hz
Power supply		3PE AC 400 V - 50 Hz
Fan motor		50 Hz - 15 kW
Acoustic level		<89 dB(A)
CE certificate		0085CL0215
Burner codes (body + head)	KN	3758210
	KM	3758211
	KL	3758212

GAS TRAINS

DUNGS

Model	Code
GT-d453-2" (*)	3750511
GT-d454-65	3750512
GT-d455-80	3750513
GT-d456-100	3750514

*: integrated filter

SIEMENS

Model	Code
GT-s452-2"	3750526
GT-s453-65	3750527
GT-s454-80	3750528
GT-s455-100	3750529
GT-s456-125	3750530

FILTERS

Model	Code
FG-Rp2"	3757200
FG-DN65	3757198
FG-DN80	3757201
FG-DN100	3757195
FG-DN125	3757209

i Pressure drops graphs: see following pages
 Dimensions of gas trains and gas filters: see page 310



DIMENSIONS (mm)

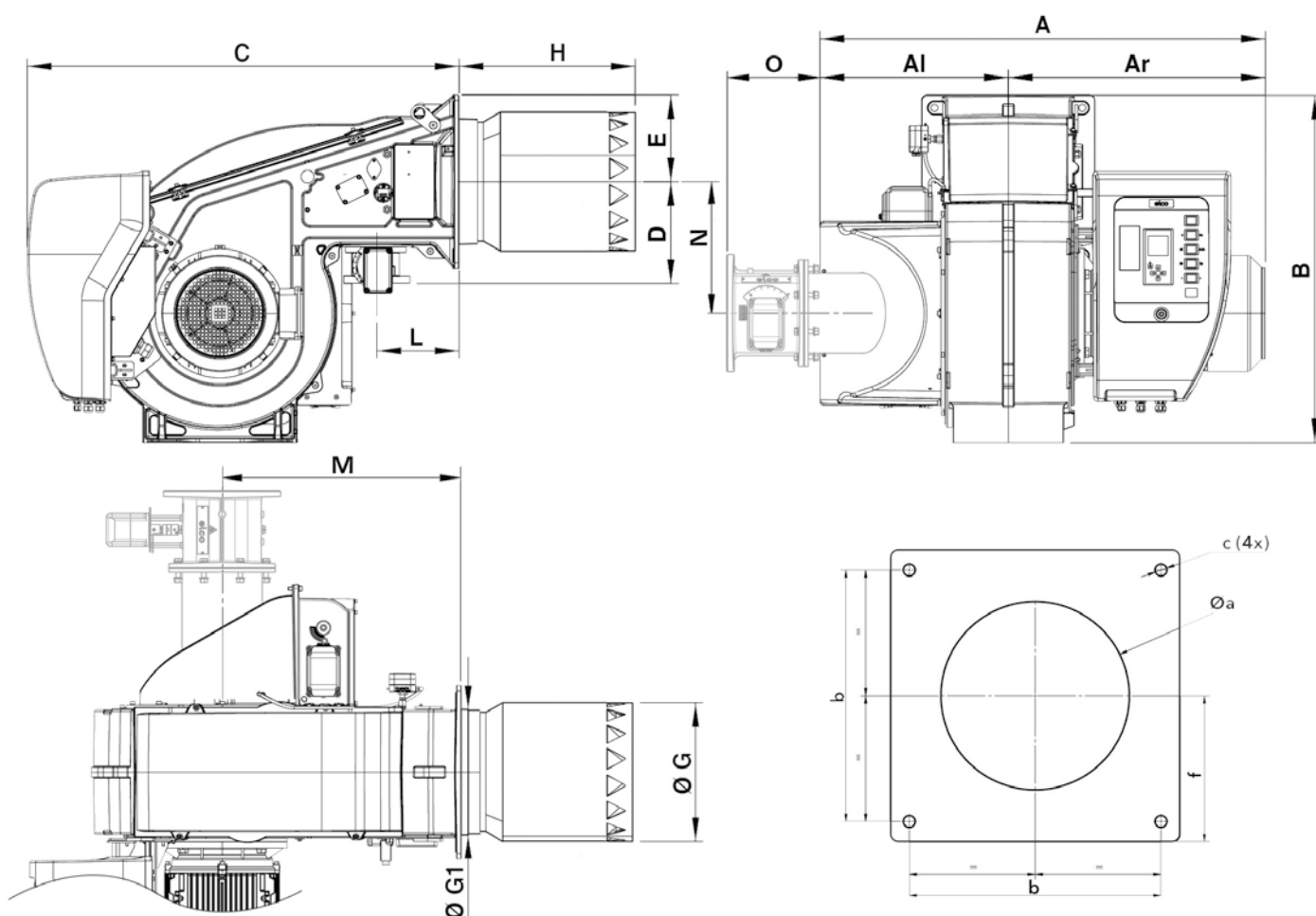

Model	A	Al	Ar	B	C	D	E	ØG	ØG1	H			L	M*	N*	O*	Øa	b	c	f
										KN	KM	KL								
EK EVO 7.7000 G-EU3	1205	510	695	941	1168	276	235	376	340	501	641	781	225	647	356	255	390-400	400	M16	235

*: in FGR configuration

PACKAGING

The burner is delivered on a pallet with:

- burner body with mounted combustion head
- gas train and filter
- boiler fixing accessories
- technical documentation

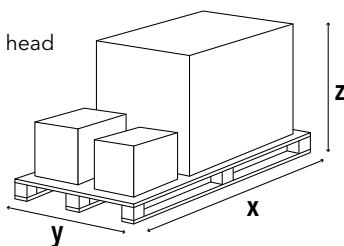

Model	Dimensions (mm)			Gross weight (kg)
	X	Y	Z	
EK EVO 7.7000 G-EU3	2046	1414	1233	350

EKEVO 7 G-EU3

610 ... 7450 kW

Two stage progressive/modulating electronic

PRESSURE LOSS [BURNER HEAD + GAS TRAIN] (mbar)

EKEVO 7.7000 G-EU3

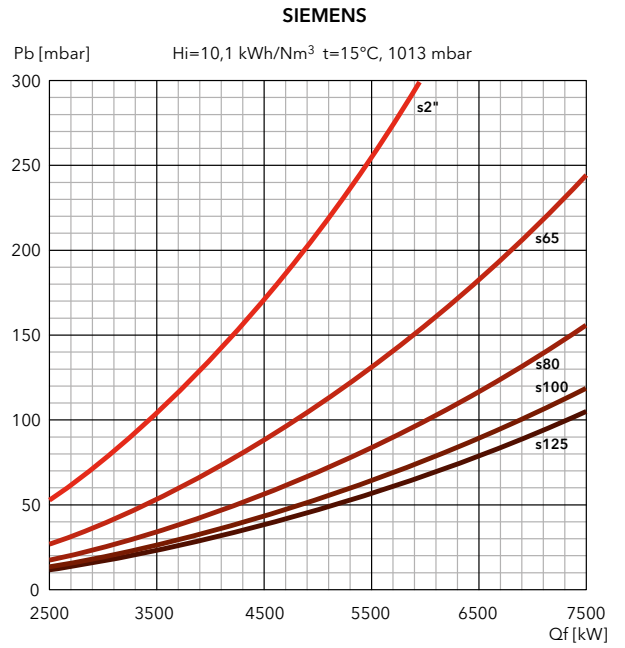
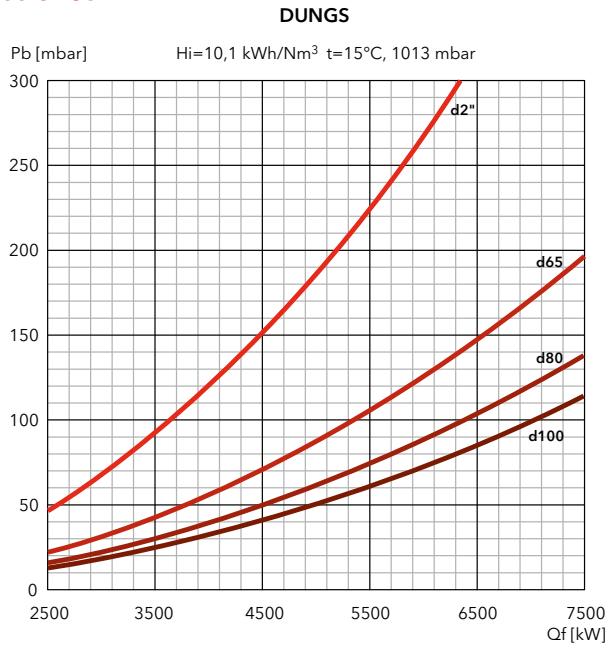



PRESSURE LOSS [BURNER HEAD + GAS TRAIN] (mbar)

FILTERS

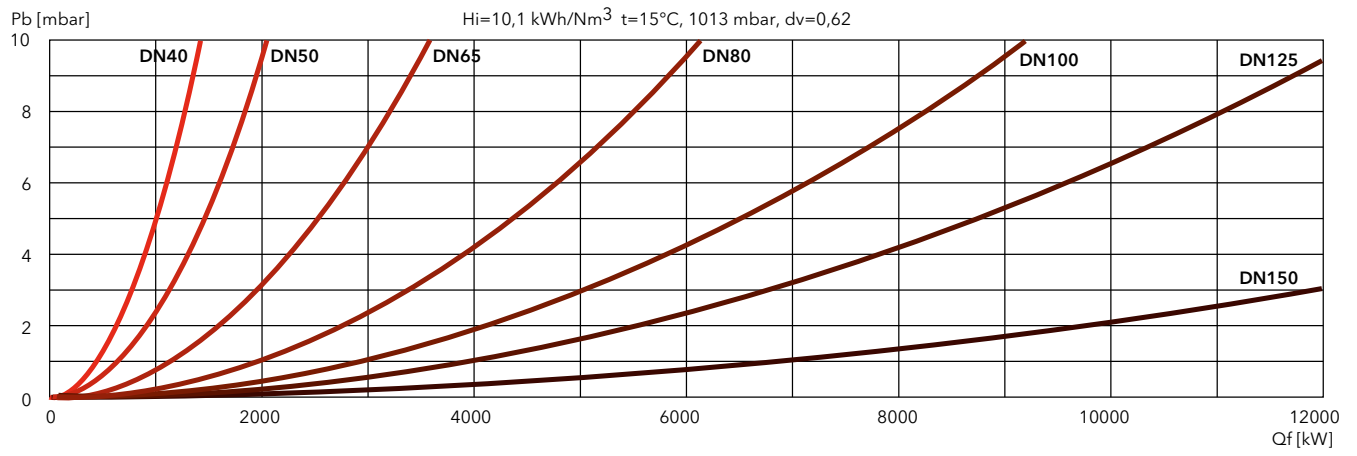

EKEVO 8 G-EU3 / EKEVO 9 G-EU3

600 ... 10500 kW

Two stage progressive/modulating electronic



- **Fuels:** natural gas, Hi = 6,99 ... 11,39 kWh/Nm³;
LPG, Hi = 25,89 kWh/Nm³
- **Emission class:** Low NOx class 3 (≤80 mg/kWh) according to EN676
- **Additional configuration:** models with FGR System (≤30 mg/kWh) available on request
- **Protection level:** IP 41

TECHNICAL DATA

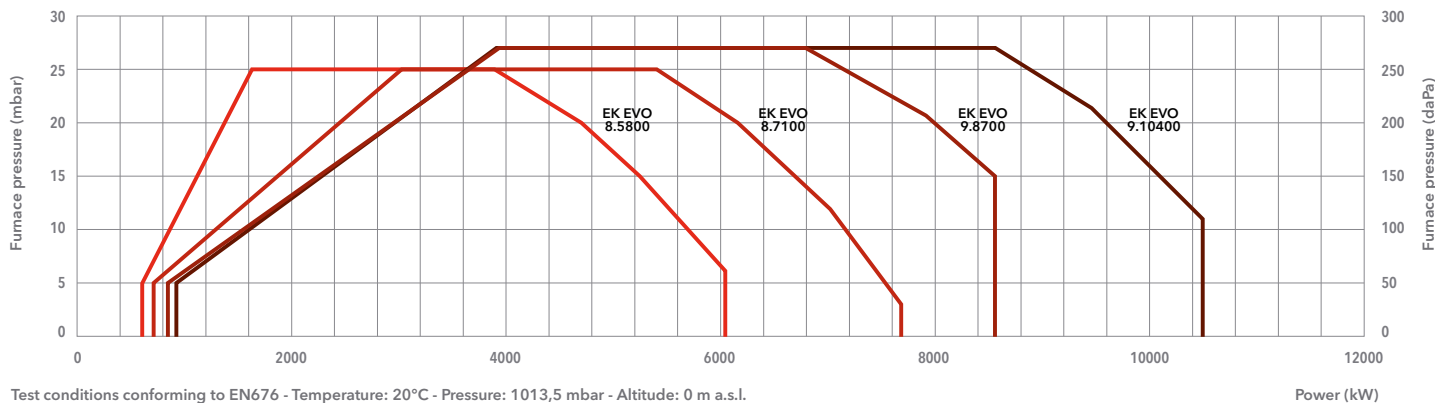

Test conditions conforming to EN676 - Temperature: 20°C - Pressure: 1013,5 mbar - Altitude: 0 m a.s.l.

	EKEVO 8.5800 G-EU3	EKEVO 8.7100 G-EU3	EKEVO 9.8700 G-EU3	EKEVO 9.10400 G-EU3
Operating range	600 – 6070 kW	700 – 7700 kW	850 – 8530 kW	910 – 10500 kW
Gas pressure	70 – 500 mbar (70 – 360 mbar for d457)		80 – 500 mbar (80 – 360 mbar for d457)	
Gas connection	DN100	DN100	DN100	DN100
Control box / flame detector	BT300 / Ionisation	BT300 / Ionisation	BT300 / Ionisation	BT300 / Ionisation
Auxiliary voltage	1NPE AC 230 V – 50 Hz TN-S	1NPE AC 230 V – 50 Hz TN-S	1NPE AC 230 V – 50 Hz TN-S	1NPE AC 230 V – 50 Hz TN-S
Power supply	3PE AC 400 V – 50 Hz	3PE AC 400 V – 50 Hz	3PE AC 400 V – 50 Hz	3PE AC 400 V – 50 Hz
Fan motor	50 Hz – 11 kW	50 Hz – 15 kW	50 Hz – 18,5 kW	50 Hz – 22 kW
Acoustic level	<80,2 dB(A)	<82,3 dB(A)	<85,4 dB(A)	<86,1 dB(A)
CE certificate	0085CL0215	0085CL0215	0085CL0215	0085CL0215
Burner codes (body + head)	KN	3753969	3753971	3753972
	KM	3753978	3753980	3753981
	KL	3753986	3753987	3753988

GAS TRAINS

DUNGS

Model	Code
GT-d457-2" (*)	3750515
GT-d458-65	3750516
GT-d459-80	3750517
GT-d460-100	3750518
GT-d125	on request

SIEMENS

Model	Code
GT-s451-1"1/2	3750525
GT-s457-2"	3750537
GT-s458-65	3750538
GT-s459-80	3750539
GT-s460-100	3750540
GT-s461-125	3750541

FILTERS

Model	Code
FG-Rp1"1/2	3757199
FG-Rp2"	3757200
FG-DN65	3757198
FG-DN80	3757201
FG-DN100	3757195
FG-DN125	3757209

*: integrated filter

i **Pressure drops graphs:** see following pages
Dimensions of gas trains and gas filters: see page 311



DIMENSIONS (mm)

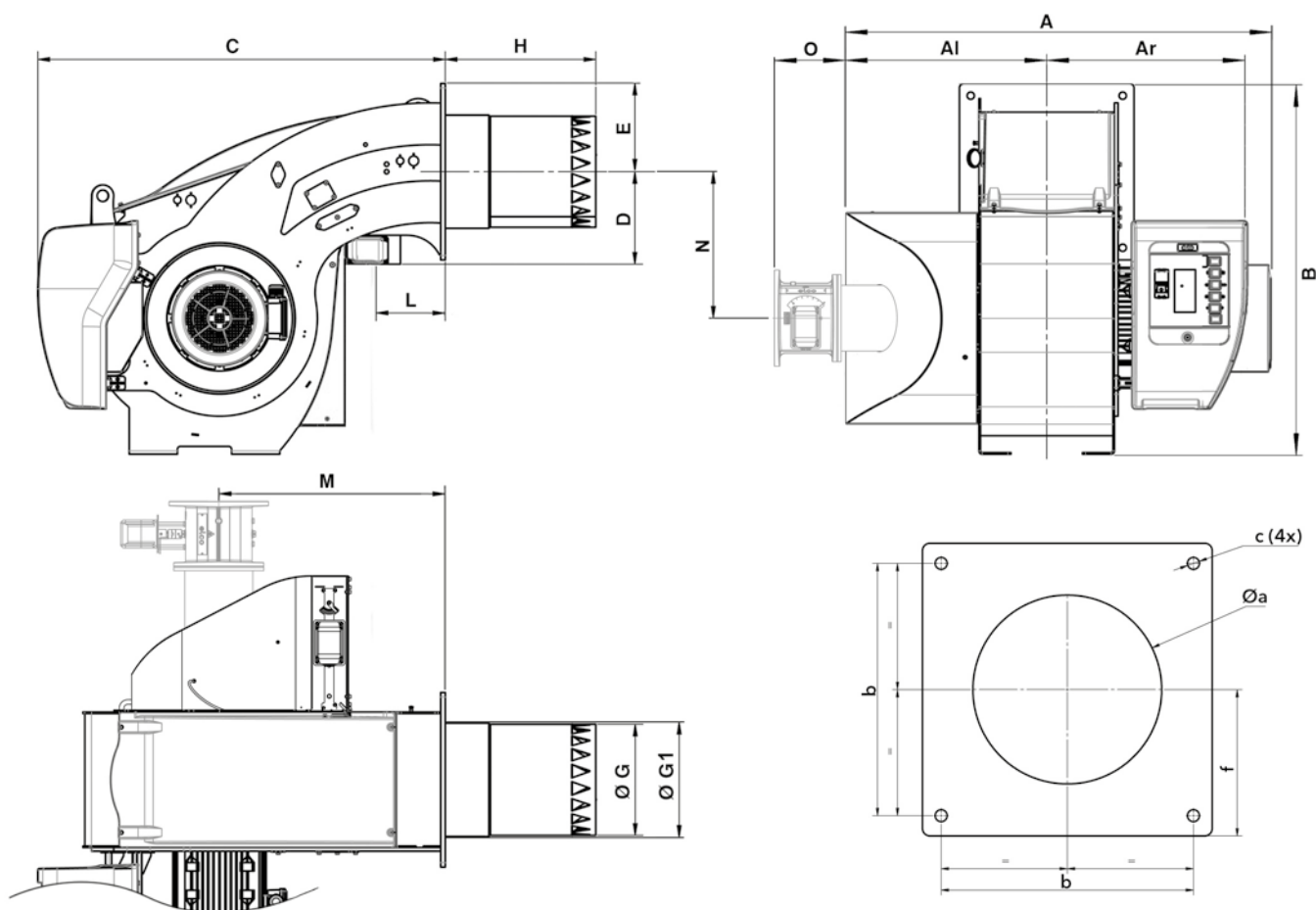

Model	A	Al	Ar	B	C	D	E	ØG	ØG1	H			L	M*	N*	O*	Øa	b	c	f
										KN	KM	KL								
EK EVO 8.5800 G-EU3	1326	670	656	1231	1354	307	293	369	376	500	640	780	230	750	487	240	385-410	505	M20	293
EK EVO 8.7100 G-EU3	1326	670	656	1231	1354	307	293	369	376	500	640	780	230	750	487	240	385-410	505	M20	293
EK EVO 9.8700 G-EU3	1326	670	656	1291	1350	332	293	431,5	438,5	550	700	850	230	750	530	240	450-480	505	M20	293
EK EVO 9.10400 G-EU3	1401	670	656	1291	1350	332	293	431,5	438,5	550	700	850	230	750	530	240	450-480	505	M20	293

*: in FGR configuration

PACKAGING

The burner is delivered on a pallet with:

- burner body with mounted combustion head
- gas train and filter
- boiler fixing accessories
- technical documentation

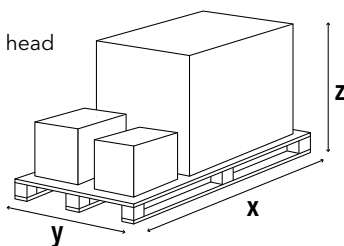

Model	Dimensions (mm)			Gross weight (kg)
	X	Y	Z	
EK EVO 8.5800 G-EU3	2300	1500	1573	580
EK EVO 8.7100 G-EU3	2300	1500	1573	580
EK EVO 9.8700 G-EU3	2300	1500	1573	700
EK EVO 9.10400 G-EU3	2300	1500	1573	700

EKEVO 8 G-EU3 / EKEVO 9 G-EU3

600 ... 10500 kW

Two stage progressive/modulating electronic

PRESSURE LOSS [BURNER HEAD + GAS TRAIN] (mbar)

EKEVO 8.5800 G-EU3

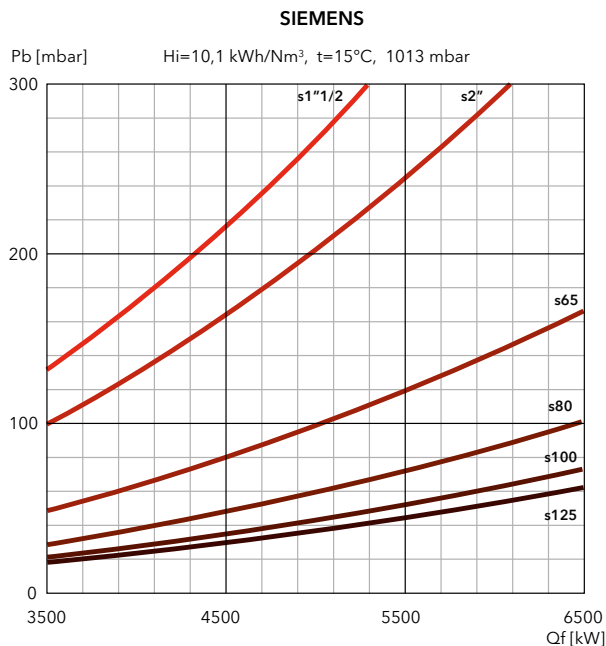
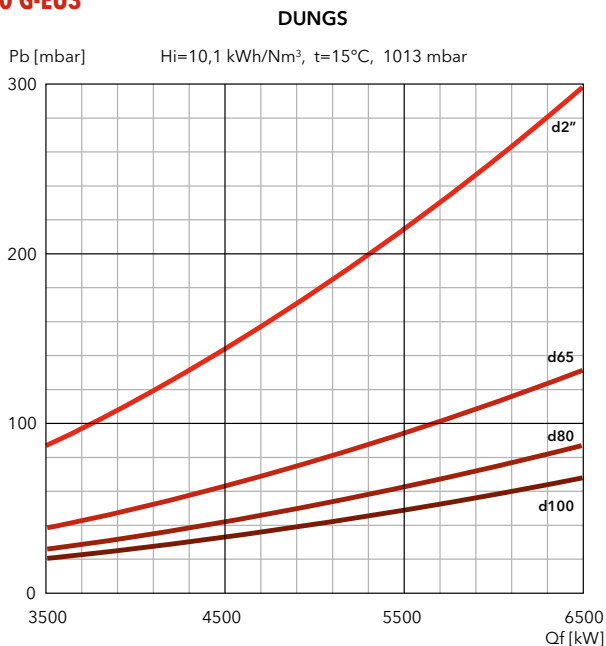

EKEVO 8.7100 G-EU3

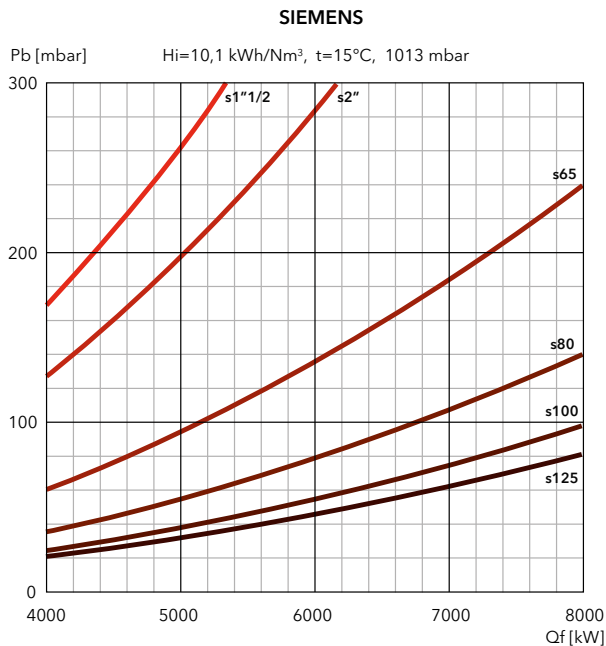
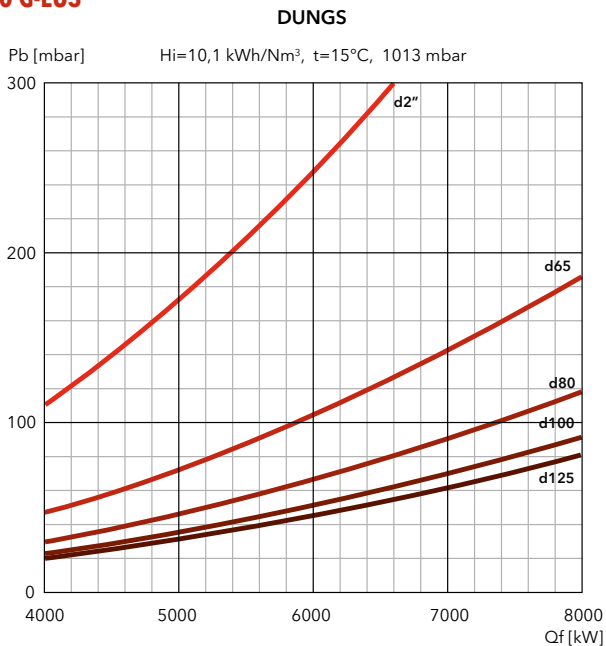

FILTERS

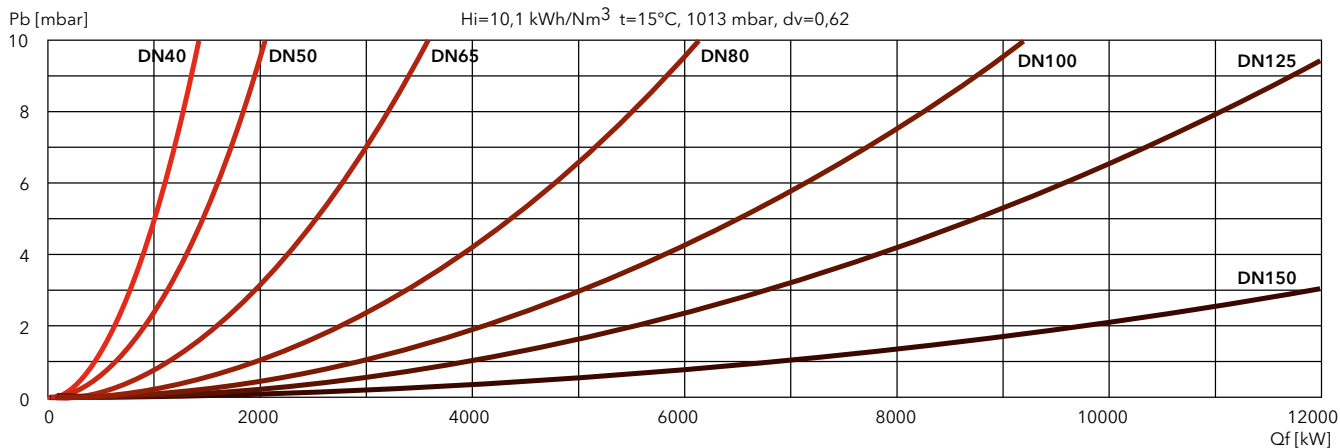



PRESSURE LOSS [BURNER HEAD + GAS TRAIN] (mbar)

EK EVO 9.8700 G-EU3

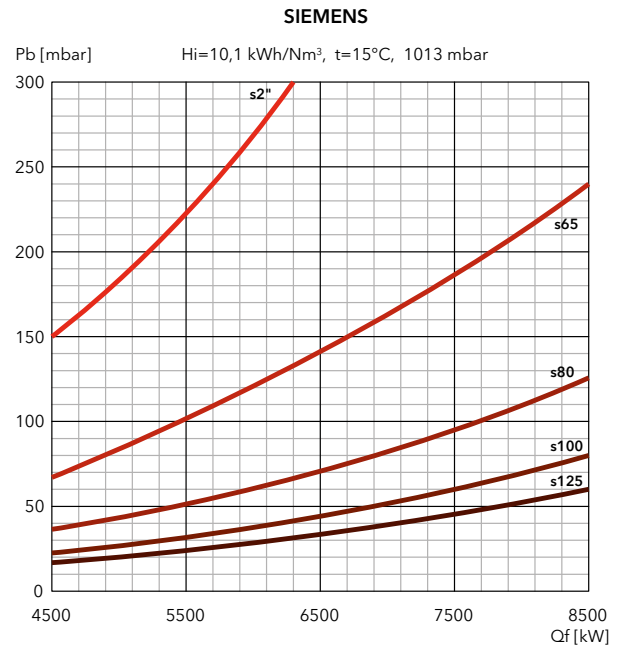
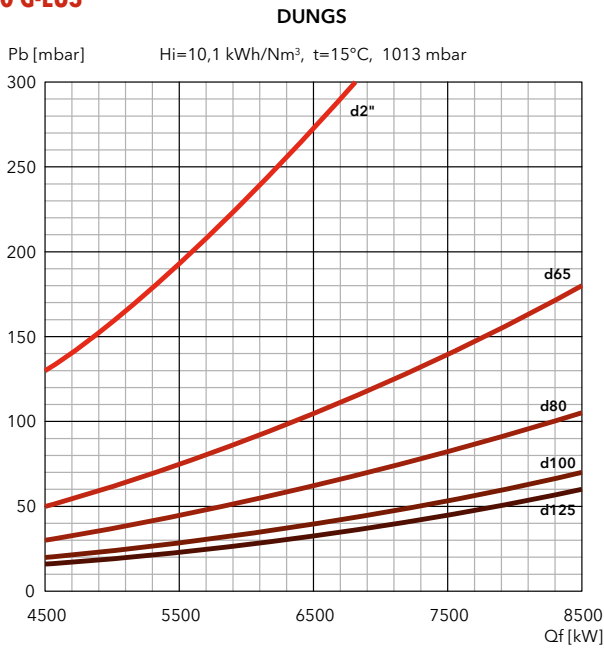

EK EVO 9.10400 G-EU3

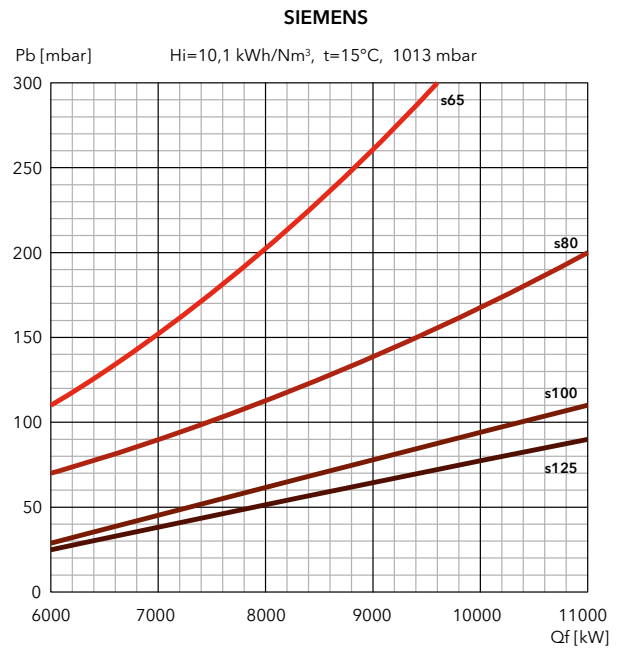
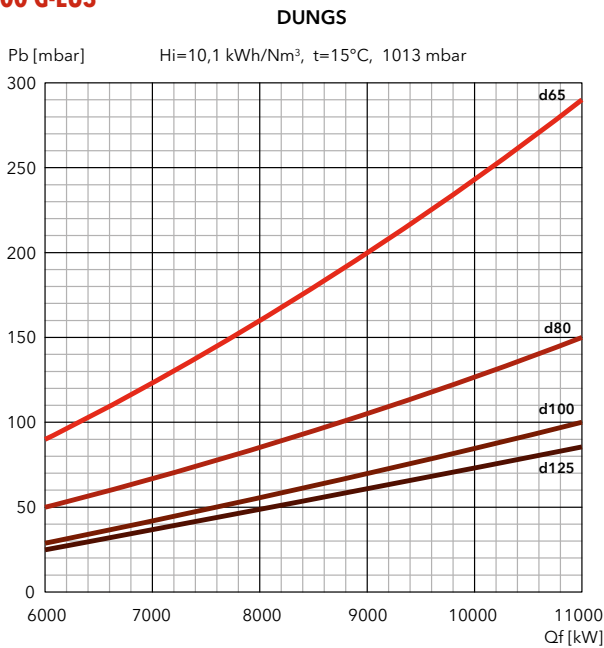

FILTERS

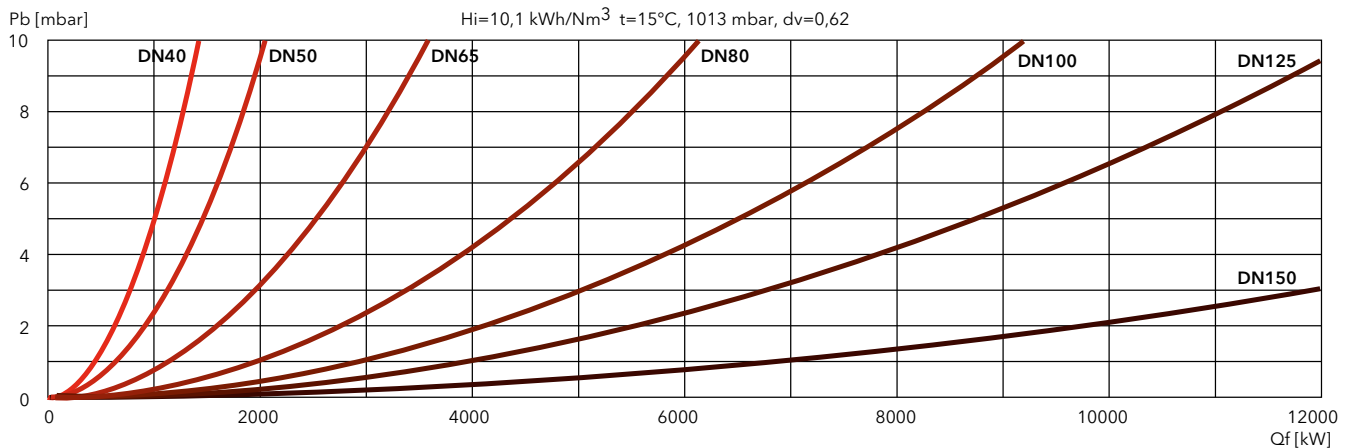

EKEVO 9 G-EU3

1350 ... 13500 kW

Two stage progressive/modulating electronic



- **Fuels:** natural gas, Hi = 6,99 ... 11,39 kWh/Nm³;
LPG, Hi = 25,89 kWh/Nm³
- **Emission class:** Low NOx class 3 (≤80 mg/kWh) according to EN676
- **Additional configuration:** model with FGR System (≤30 mg/kWh) available on request
- **Protection level:** IP 41

TECHNICAL DATA

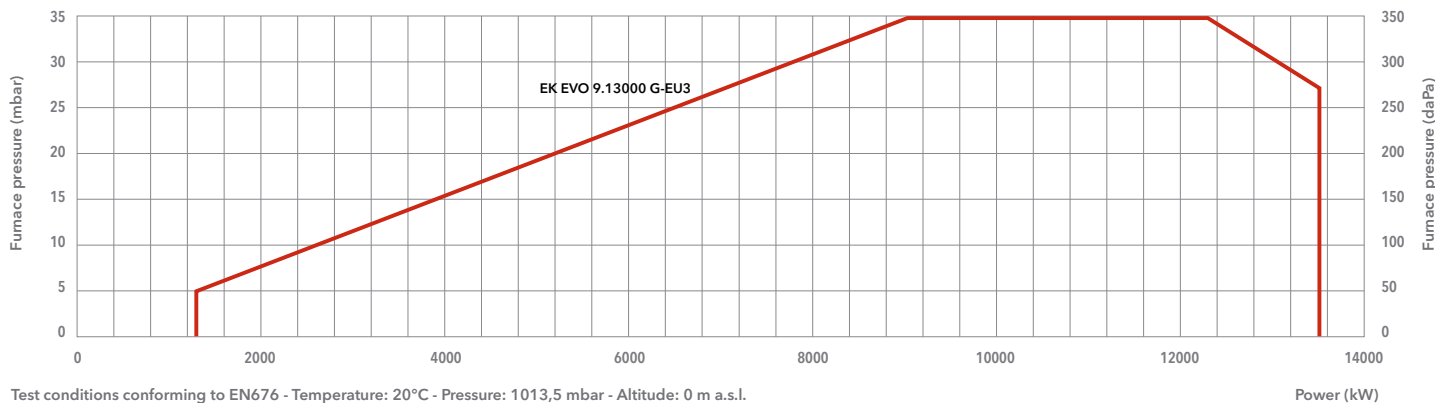

		EKEVO 9.13000 G-EU3
Operating range		1350 - 13500 kW
Gas pressure		130 - 500 mbar
Gas connection		DN100
Control box / flame detector		BT300 / QRA2
Auxiliary voltage		1NPE AC 230 V - 50/60 Hz
Power supply		3PE AC 400 V - 50 Hz
Fan motor		50 Hz - 37 kW
Acoustic level		<93,5 dB(A)
CE certificate		0085CL0215
Burner codes (body + head)	KN	3758162
	KM	3758163
	KL	3758164

GAS TRAINS

DUNGS

Model	Code
GT-d459-80	3750517
GT-d460-100	3750518
GT-d125	on request

SIEMENS

Model	Code
GT-s459-80	3750539
GT-s460-100	3750540
GT-s461-125	3750541
GT-s150	on request

FILTERS

Model	Code
FG-DN80	3757201
FG-DN100	3757195
FG-DN125	3757209
FG-DN150	3757210

i Pressure drops graphs: see following pages
Dimensions of gas trains and gas filters: see page 311



DIMENSIONS (mm)

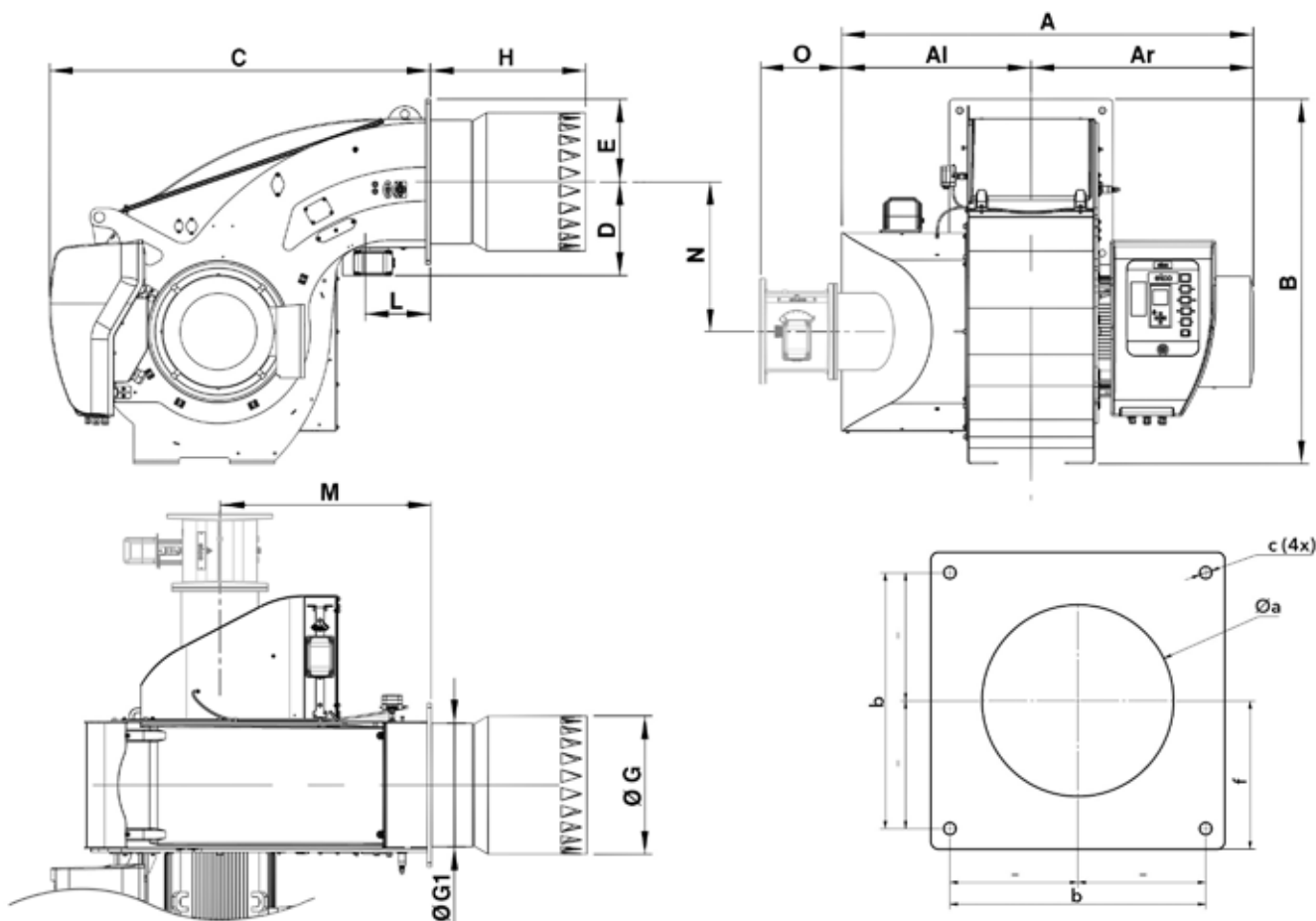

Model	A	Al	Ar	B	C	D	E	ØG	ØG1	H			L	M*	N*	O*	Øa	b	c	f
										KN	KM	KL								
EK EVO 9.13000 G-EU3	1456	669	788	1286	1348	332	293	490	439	550	700	850	230	750	530	291	510-520	505	M20	293

*: in FGR configuration

PACKAGING

The burner is delivered on a pallet with:

- burner body with mounted combustion head
- gas train and filter
- boiler fixing accessories
- technical documentation

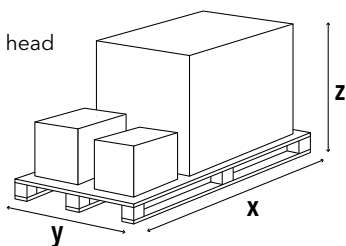

Model	Dimensions (mm)			Gross weight (kg)
	X	Y	Z	
EK EVO 9.13000 G-EU3	2300	1500	1573	700

EKEVO 9 G-EU3

1350 ... 13500 kW

Two stage progressive/modulating electronic

PRESSURE LOSS [BURNER HEAD + GAS TRAIN] (mbar)

EK EVO 9.13000 G-EU3

DUNGS

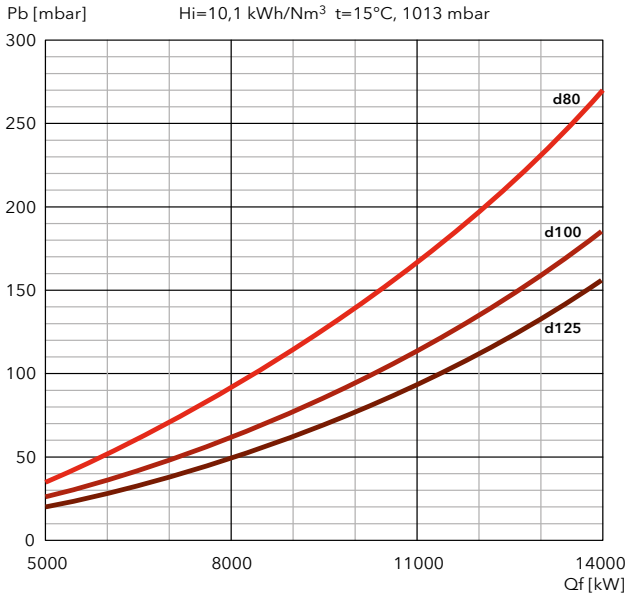

SIEMENS

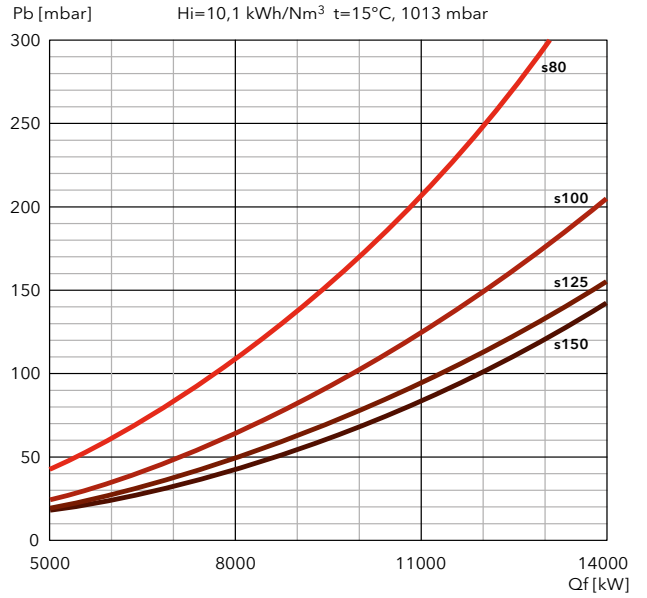



PRESSURE LOSS [BURNER HEAD + GAS TRAIN] (mbar)

FILTERS

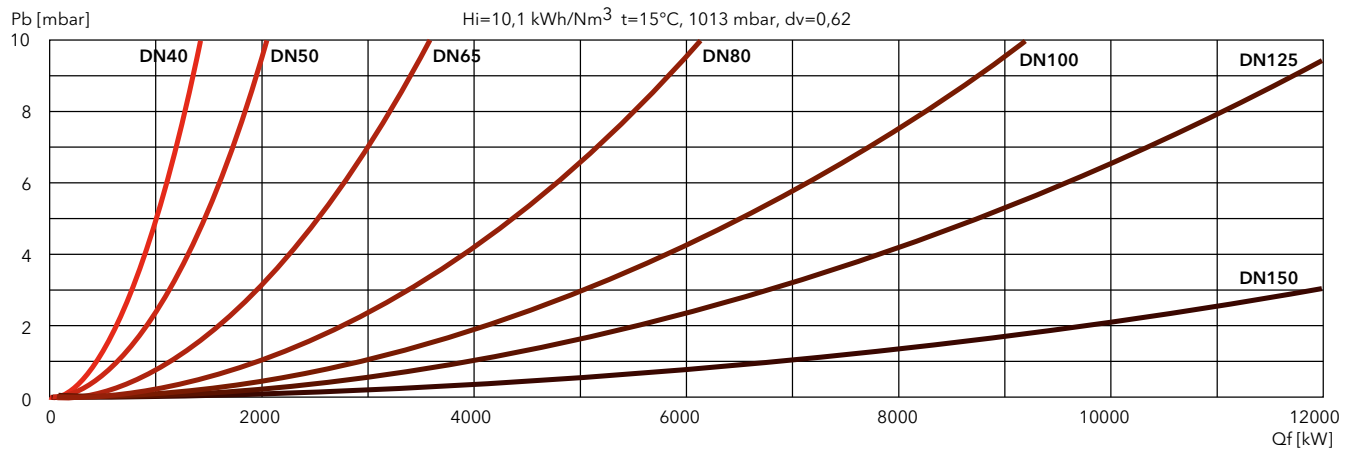

EKEVO 6 G-EU2N / EKEVO 7 G-EU2N

360 ... 3720 kW

Two stage progressive/modulating electronic



- **Fuels:** natural gas, Hi = 6,99 ... 11,39 kWh/Nm³;
LPG, Hi = 25,89 kWh/Nm³
- **Emission class:** Low NOx class 3 (≤80 mg/kWh) according to EN676
- **Protection level:** IP 41

TECHNICAL DATA

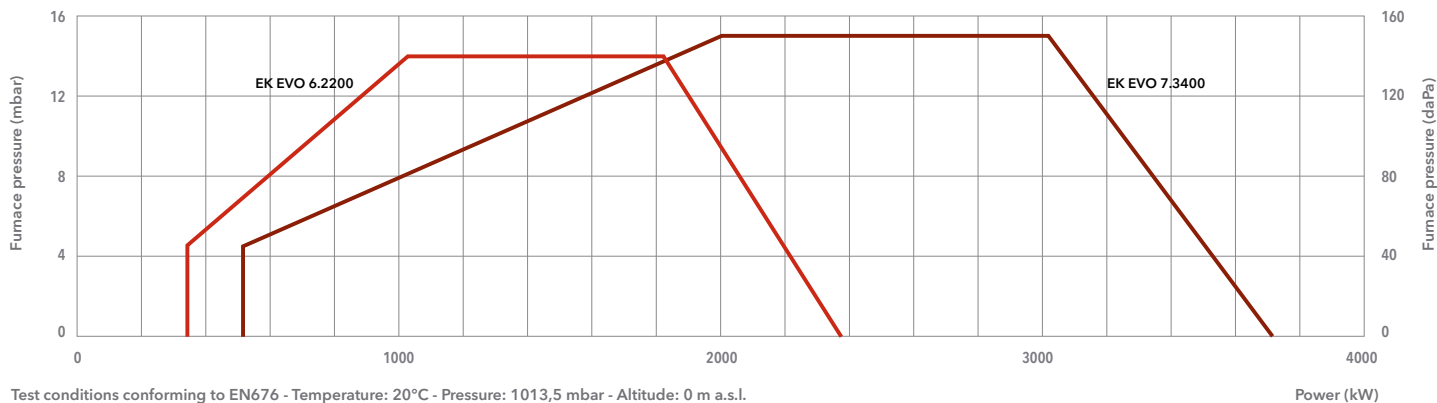

Test conditions conforming to EN676 - Temperature: 20°C - Pressure: 1013,5 mbar - Altitude: 0 m a.s.l.

	EKEVO 6.2200 G-EU2N	EKEVO 7.3400 G-EU2N	
Operating range	360 – 2380 kW	530 – 3720 kW	
Gas pressure	75 – 500 mbar (75 – 360 mbar for d452 and d453)	80 – 500 mbar (80 – 360 mbar for d452 and d453)	
Gas connection	DN65	DN65	
Control box / flame detector	BT300 / QRA 2	BT300 / QRA 2	
Auxiliary voltage	1NPE AC 230 V – 50 Hz TN-S	1NPE AC 230 V – 50 Hz TN-S	
Power supply	3PE AC 400 V – 50 Hz	3PE AC 400 V – 50 Hz	
Fan motor	50 Hz – 4 kW	50 Hz – 7,5 kW	
Acoustic level	<77 dB(A)	<83 dB(A)	
CE certificate	0085CL0215	0085CL0215	
Burner codes (body + head)	KN	3754672	3754681
	KM	3754673	3754682
	KL	3754674	3754683

GAS TRAINS

DUNGS

Model	Code
GT-d452-1"1/2 (*)	3750510
GT-d453-2" (*)	3750511
GT-d454-65	3750512
GT-d455-80	3750513
GT-d456-100	3750514

SIEMENS

Model	Code
GT-s451-1"1/2	3750525
GT-s452-2"	3750526
GT-s453-65	3750527
GT-s454-80	3750528
GT-s455-100	3750529

FILTERS

Model	Code
FG-Rp1"1/2	3757199
FG-Rp2"	3757200
FG-DN65	3757198
FG-DN80	3757201
FG-DN100	3757195

*: integrated filter

i **Pressure drops graphs:** see following pages
Dimensions of gas trains and gas filters: see page 310



DIMENSIONS (mm)

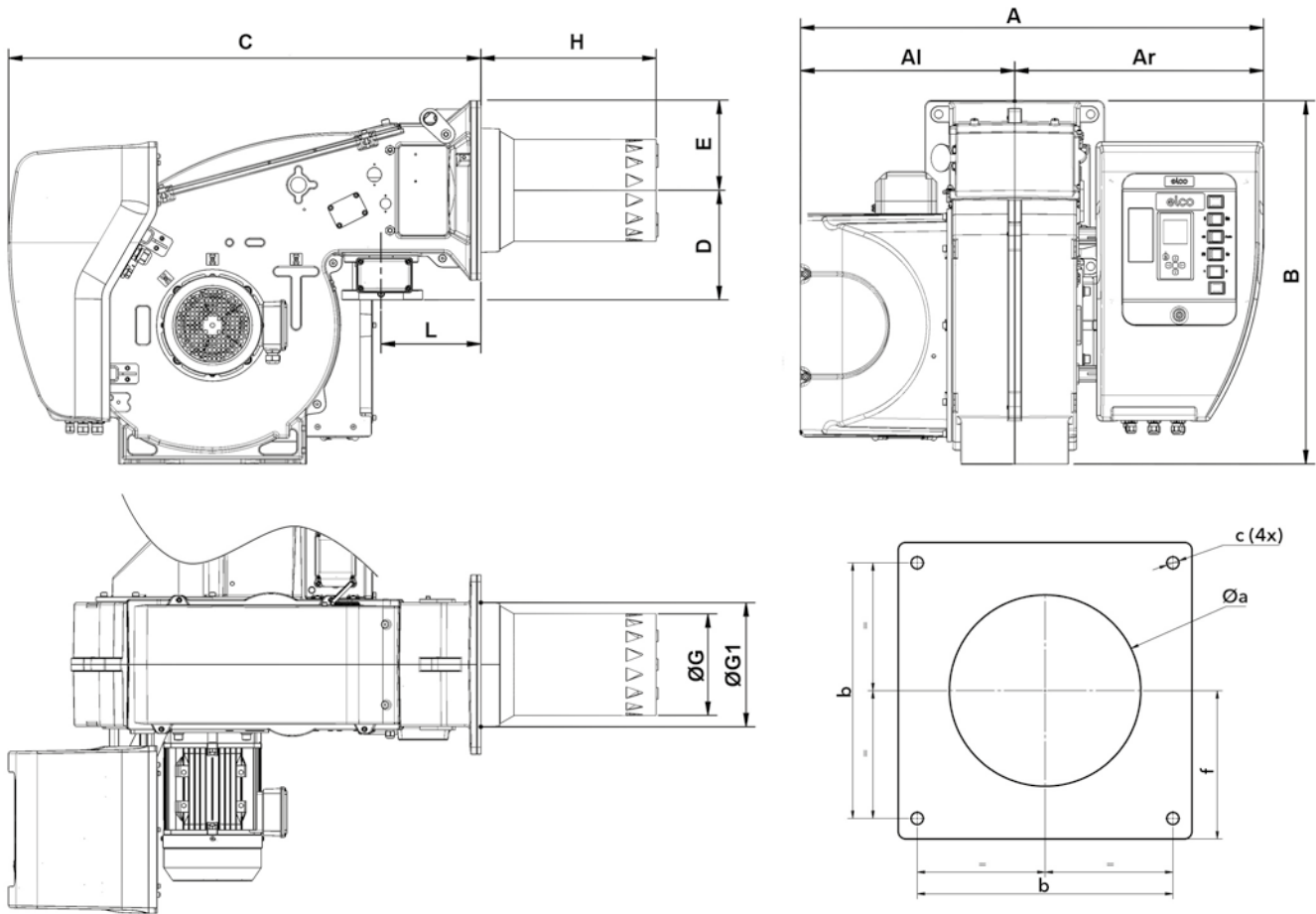

Model	A	Al	Ar	B	C	D	E	ØG	ØG1	H			L	Øa	b	c	f
										KN	KM	KL					
EK EVO 6.2200 G-EU2N	1035	479	556	812	1056	245	200	227	277	400	520	640	215	300-340	340	M16	200
EK EVO 7.3400 G-EU2N	1106	510	597	941	1130	276	235	263	343	420	550	680	225	360-400	400	M16	235

PACKAGING

The burner is delivered on a pallet with:

- burner body with mounted combustion head
- gas train and filter
- boiler fixing accessories
- technical documentation

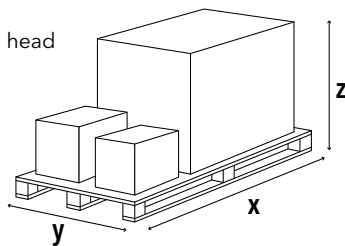

Model	Dimensions (mm)			Gross weight (kg)
	X	Y	Z	
EK EVO 6.2200 G-EU2N	2046	1414	1233	300
EK EVO 7.3400 G-EU2N	2046	1414	1233	350

EKEVO 6 G-EU2N / EKEVO 7 G-EU2N

360 ... 3720 kW

Two stage progressive/modulating electronic

PRESSURE LOSS [BURNER HEAD + GAS TRAIN] (mbar)

EKEVO 6.2200 G-EU2N

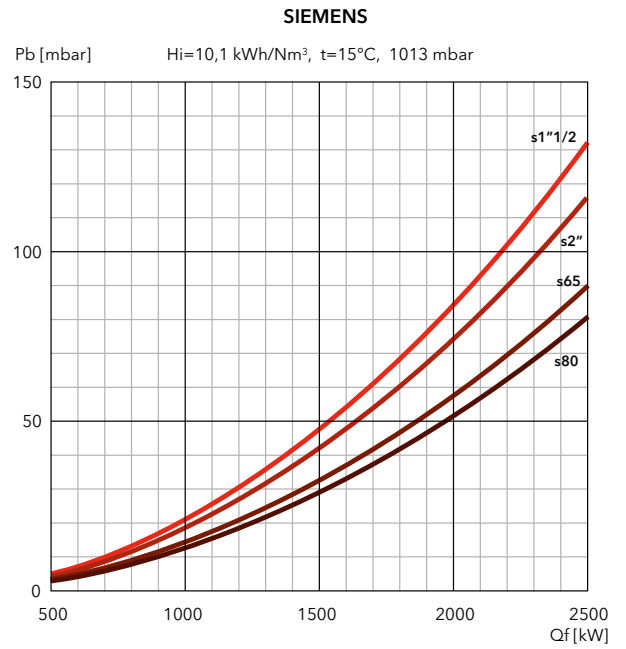
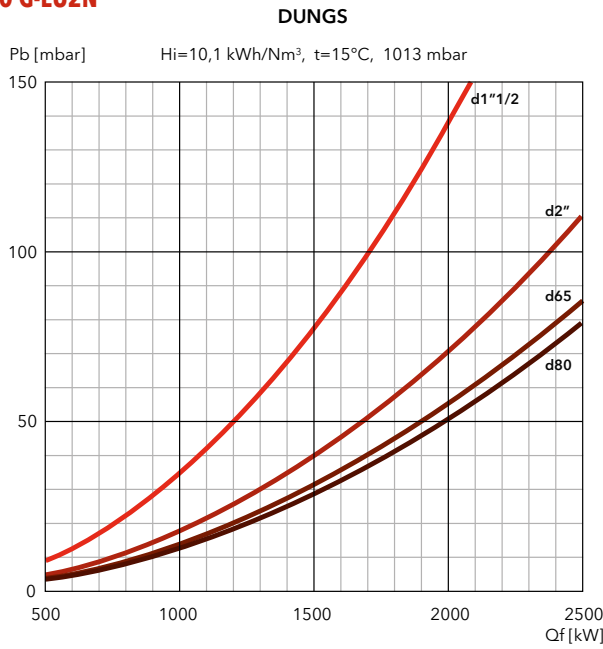

FILTERS

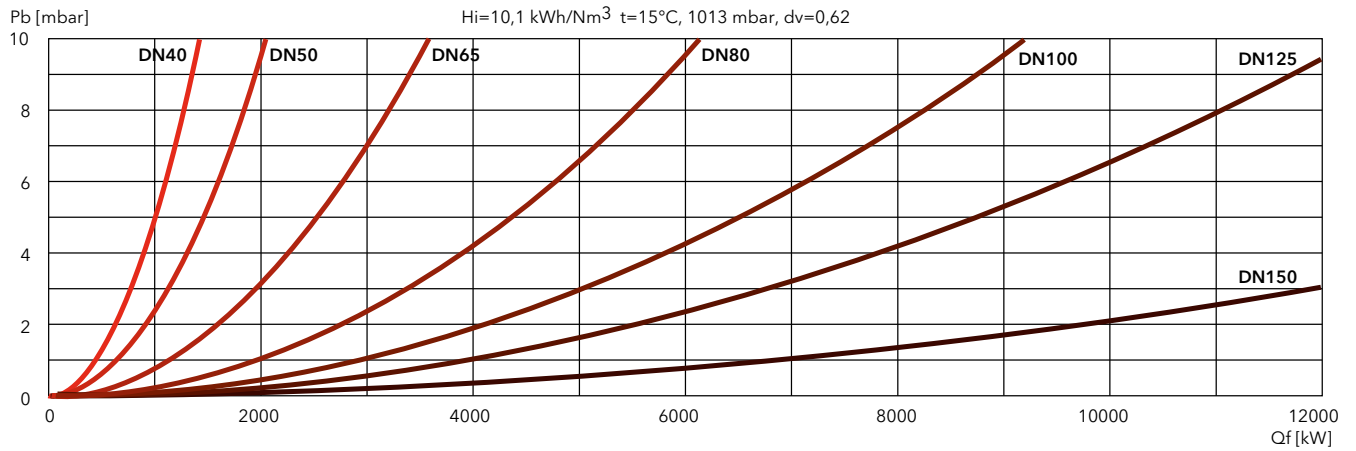



PRESSURE LOSS [BURNER HEAD + GAS TRAIN] (mbar)

EK EVO 7.3400 G-EU2N

DUNGS

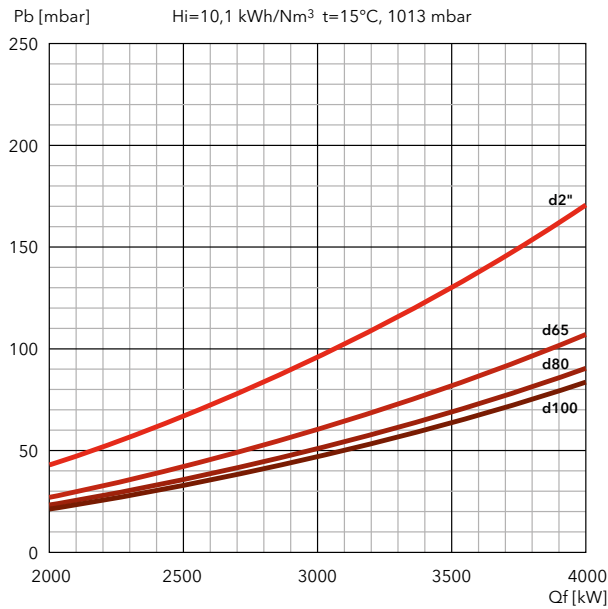

SIEMENS

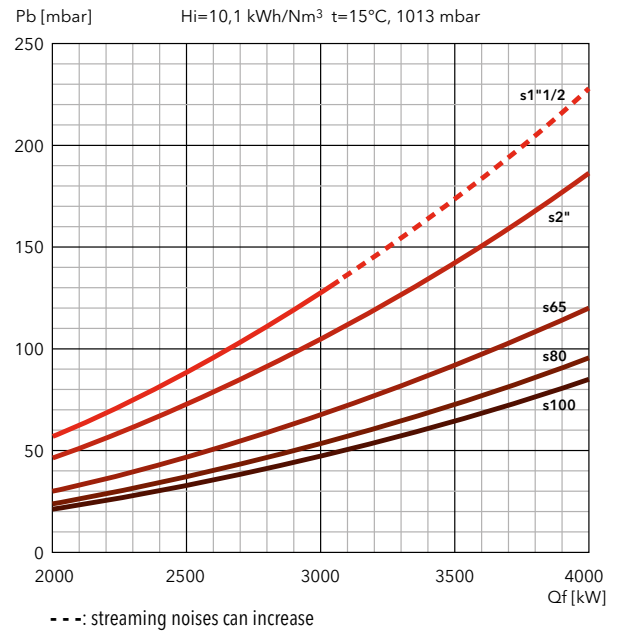

FILTERS

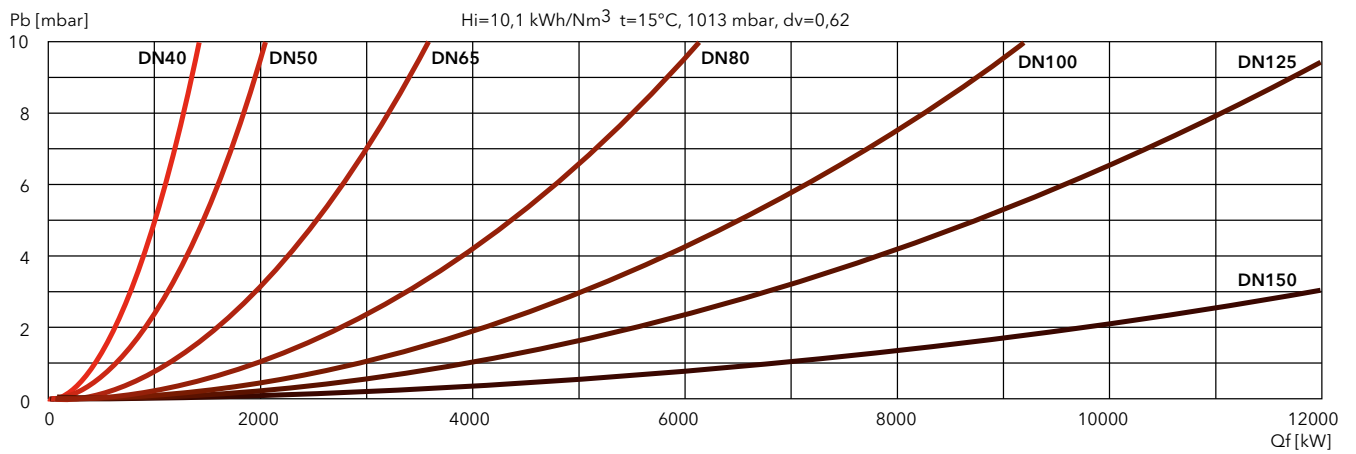

EKEVO 6 G-EU2

365 ... 3050 kW

Two stage progressive/modulating electronic



- **Fuels:** natural gas, Hi = 6,99 ... 11,39 kWh/Nm³;
LPG, Hi = 25,89 kWh/Nm³
- **Emission class:** Low NOx class 3 (≤80 mg/kWh) according to EN676
- **Additional configuration:** models with FGR System (≤30 mg/kWh) available on request
- **Protection level:** IP 41

TECHNICAL DATA

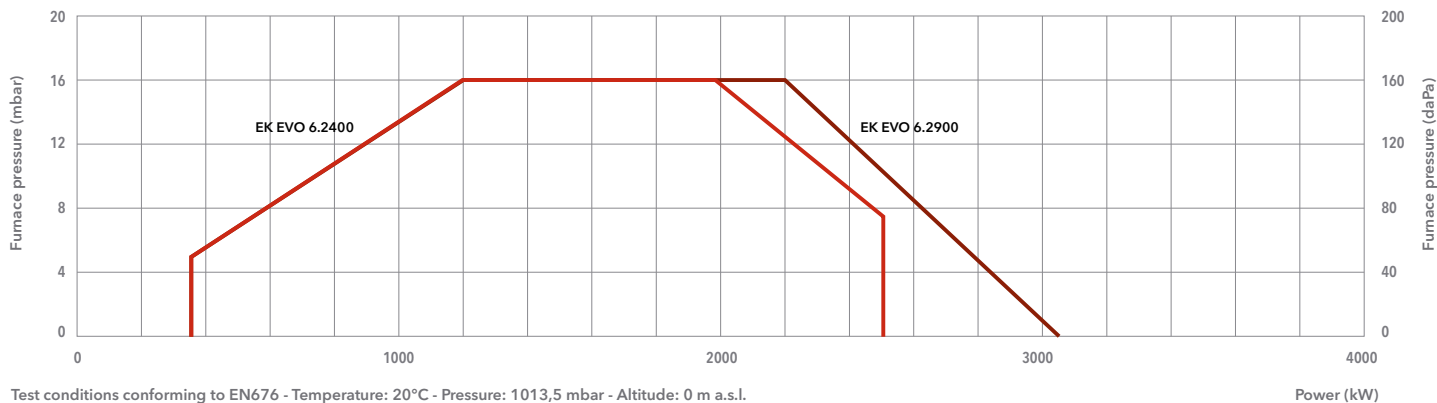

Test conditions conforming to EN676 - Temperature: 20°C - Pressure: 1013,5 mbar - Altitude: 0 m a.s.l.

	EK EVO 6.2400 G-EU2	EK EVO 6.2900 G-EU2
Operating range	365 - 2530 kW	365 - 3050 kW
Gas pressure	55 - 500 mbar (55 - 360 mbar for d452 and d453)	75 - 500 mbar (75 - 360 mbar for d452 and d453)
Gas connection	DN65	DN65
Control box / flame detector	BT300 / QRA 2	BT300 / QRA 2
Auxiliary voltage	1NPE AC 230 V - 50 Hz TN-S	1NPE AC 230 V - 50 Hz TN-S
Power supply	3PE AC 400 V - 50 Hz	3PE AC 400 V - 50 Hz
Fan motor	50 Hz - 3 kW	50 Hz - 4 kW
Acoustic level	<74 dB(A)	<77 dB(A)
CE certificate	0085CL0215	0085CL0215
Burner codes (body + head)	KN	on request
	KM	on request
	KL	on request

GAS TRAINS

DUNGS

Model	Code
GT-d452-1"1/2 (*)	3750510
GT-d453-2" (*)	3750511
GT-d454-65	3750512
GT-d455-80	3750513

*: integrated filter

SIEMENS

Model	Code
GT-s451-1"1/2	3750525
GT-s452-2"	3750526
GT-s453-65	3750527
GT-s454-80	3750528
GT-s455-100	3750529

FILTERS

Model	Code
FG-Rp1"1/2	3757199
FG-Rp2"	3757200
FG-DN65	3757198
FG-DN80	3757201
FG-DN100	3757195

i Pressure drops graphs: see following pages
 Dimensions of gas trains and gas filters: see page 310



DIMENSIONS (mm)

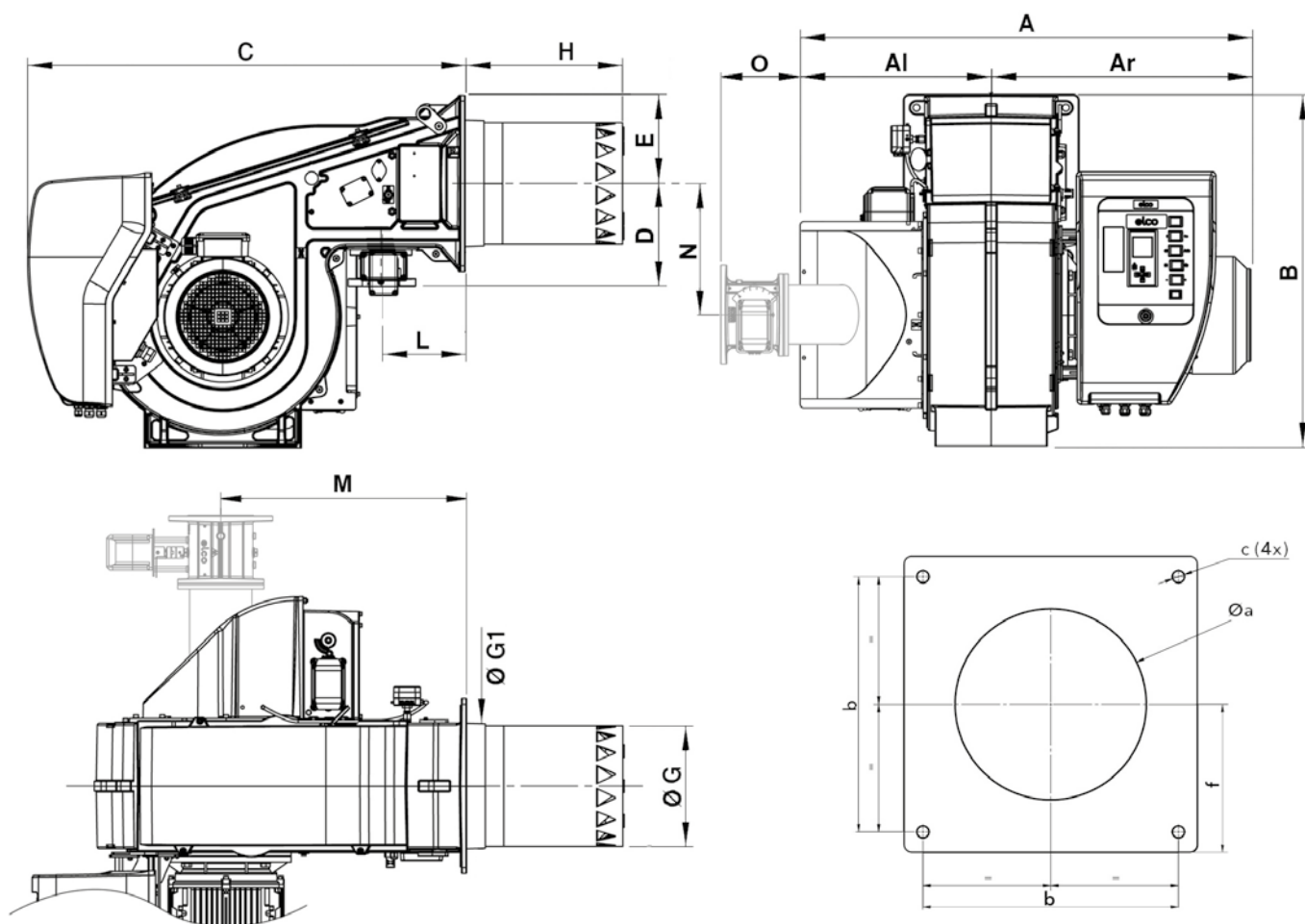

Model	A	Al	Ar	B	C	D	E	ØG	ØG1	H			L	M*	N*	O*	Øa	b	c	f
										KN	KM	KL								
EKEVO 6... G-EU2	1035	479	556	812	1048	245	200	263	277	400	520	640	215	600	302	218	300-340	340	M16	200

*: in FGR configuration

PACKAGING

The burner is delivered on a pallet with:

- burner body with mounted combustion head
- gas train and filter
- boiler fixing accessories
- technical documentation

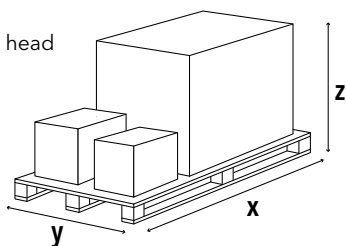

Model	Dimensions (mm)			Gross weight (kg)
	X	Y	Z	
EK EVO 6.2400 G-EU2	2046	1414	1233	300
EK EVO 6.2900 G-EU2	2046	1414	1233	350

EKEVO 6 G-EU2

365 ... 3050 kW

Two stage progressive/modulating electronic

PRESSURE LOSS [BURNER HEAD + GAS TRAIN] (mbar)

EKEVO 6.2400 G-EU2

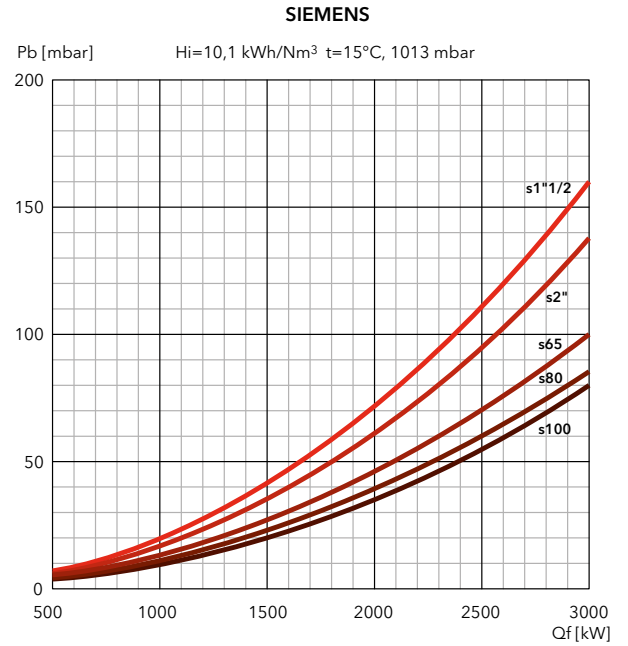
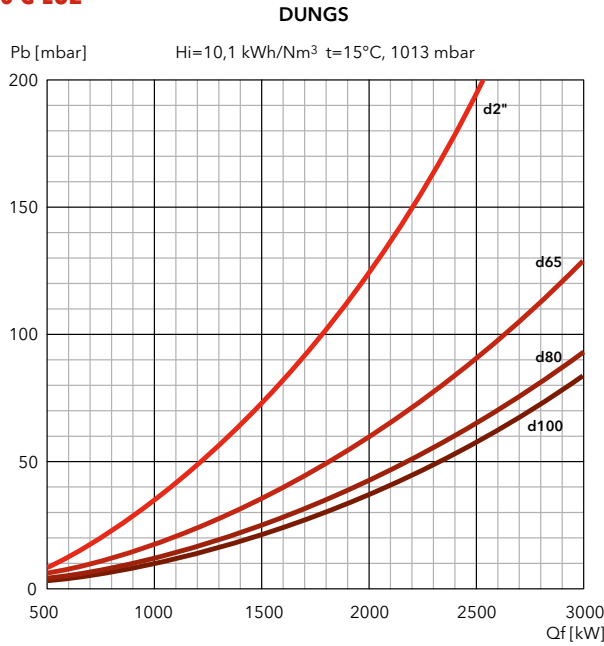

FILTERS

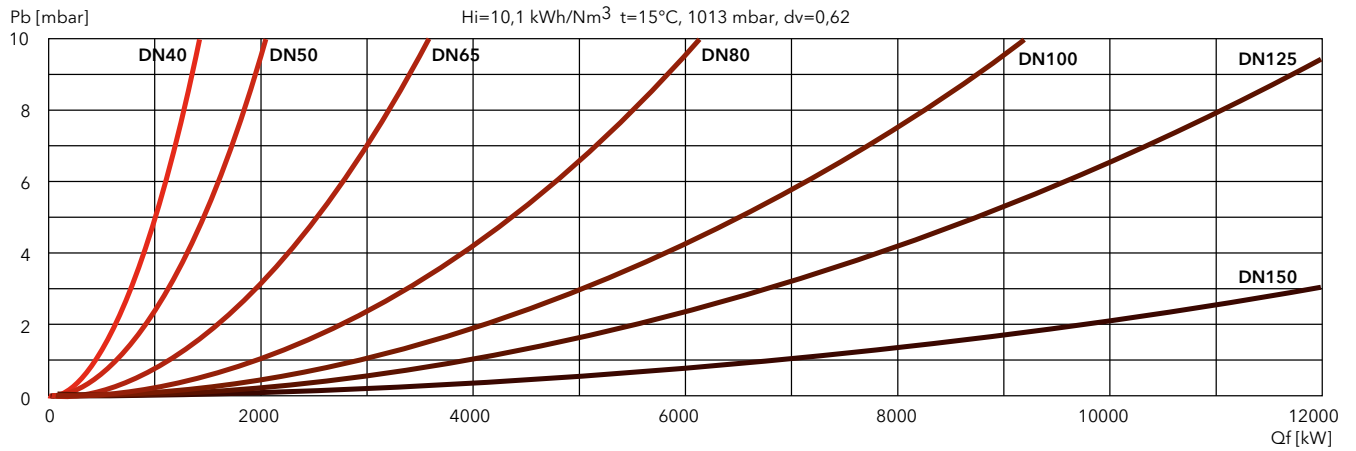



PRESSURE LOSS [BURNER HEAD + GAS TRAIN] (mbar)

EK EVO 6.2900 G-EU2

DUNGS

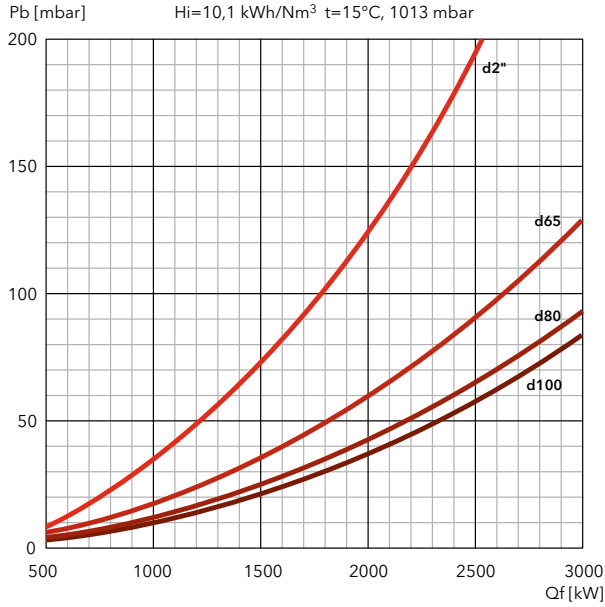

SIEMENS

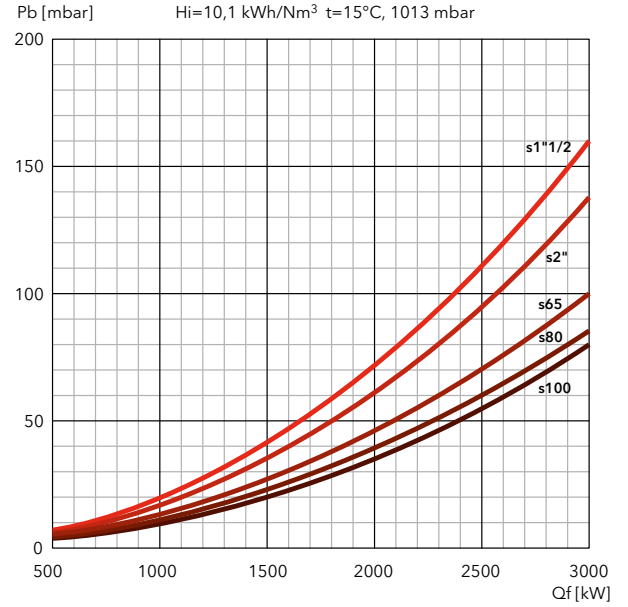

FILTERS

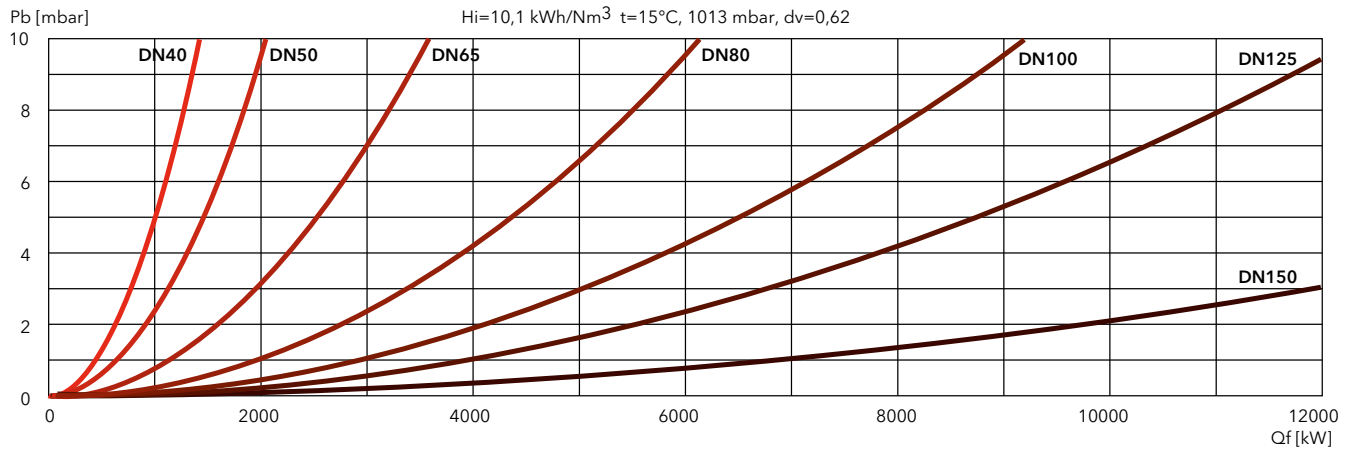

EKEVO 7 G-EU2

490 ... 5850 kW

Two stage progressive/modulating electronic



- **Fuels:** natural gas, Hi = 6,99 ... 11,39 kWh/Nm³;
LPG, Hi = 25,89 kWh/Nm³
- **Emission class:** Low NOx class 3 (≤80 mg/kWh) according to EN676
- **Additional configuration:** models with FGR System (≤30 mg/kWh) available on request
- **Protection level:** IP 41

TECHNICAL DATA

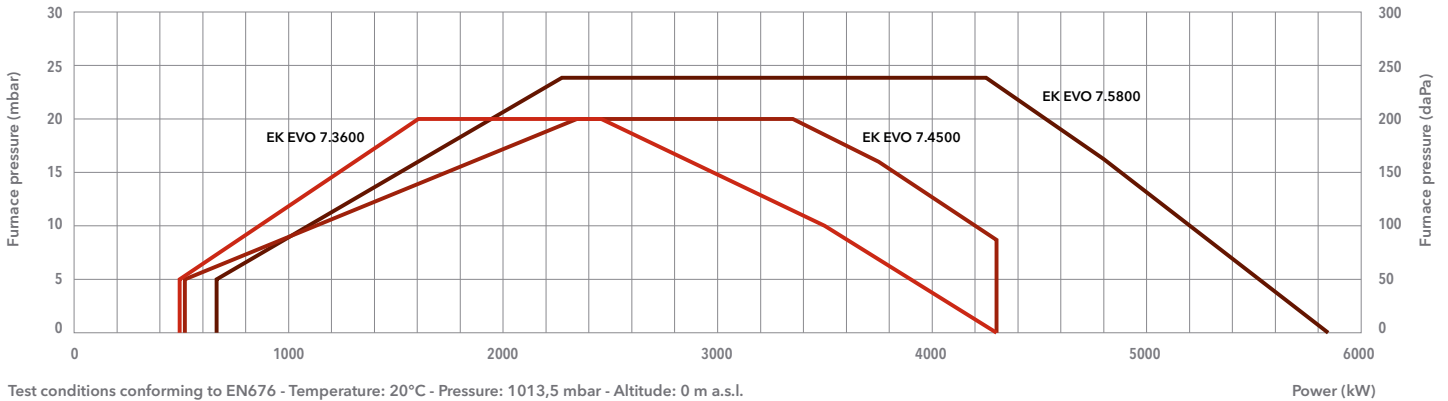

Test conditions conforming to EN676 - Temperature: 20°C - Pressure: 1013,5 mbar - Altitude: 0 m a.s.l.

	EK EVO 7.3600 G-EU2	EK EVO 7.4500 G-EU2	EK EVO 7.5800 G-EU2
Operating range	490 - 4290 kW	510 - 4290 kW	630 - 5850 kW
Gas pressure	75 - 500 mbar (75 - 360 mbar for d453)	75 - 500 mbar (75 - 360 mbar for d453)	105 - 500 mbar (105 - 360 mbar for d453)
Gas connection	DN65	DN65	DN65
Control box / flame detector	BT300 / QRA2	BT300 / QRA2	BT300 / QRA2
Auxiliary voltage	1NPE AC 230 V - 50 Hz	1NPE AC 230 V - 50 Hz	1NPE AC 230 V - 50 Hz
Power supply	3PE AC 400 V - 50 Hz	3PE AC 400 V - 50 Hz	3PE AC 400 V - 50 Hz
Fan motor	50 Hz - 5,5 kW	50 Hz - 7,5 kW	50 Hz - 15 kW
Acoustic level	<81 dB(A)	<83 dB(A)	<85 dB(A)
CE certificate	0085CL0215	0085CL0215	0085CL0215
Burner codes (body + head)	KN	on request	3755338
	KM	on request	3755339
	KL	on request	3755340

GAS TRAINS

DUNGS

Model	Code
GT-d453-2" (*)	3750511
GT-d454-65	3750512
GT-d455-80	3750513
GT-d456-100	3750514

*: integrated filter

SIEMENS

Model	Code
GT-s451-1"1/2	3750525
GT-s452-2"	3750526
GT-s453-65	3750527
GT-s454-80	3750528
GT-s455-100	3750529
GT-s456-125	3750530

FILTERS

Model	Code
FG-Rp1"1/2	3757199
FG-Rp2"	3757200
FG-DN65	3757198
FG-DN80	3757201
FG-DN100	3757195
FG-DN125	3757209

i Pressure drops graphs: see following pages
Dimensions of gas trains and gas filters: see page 310



DIMENSIONS (mm)

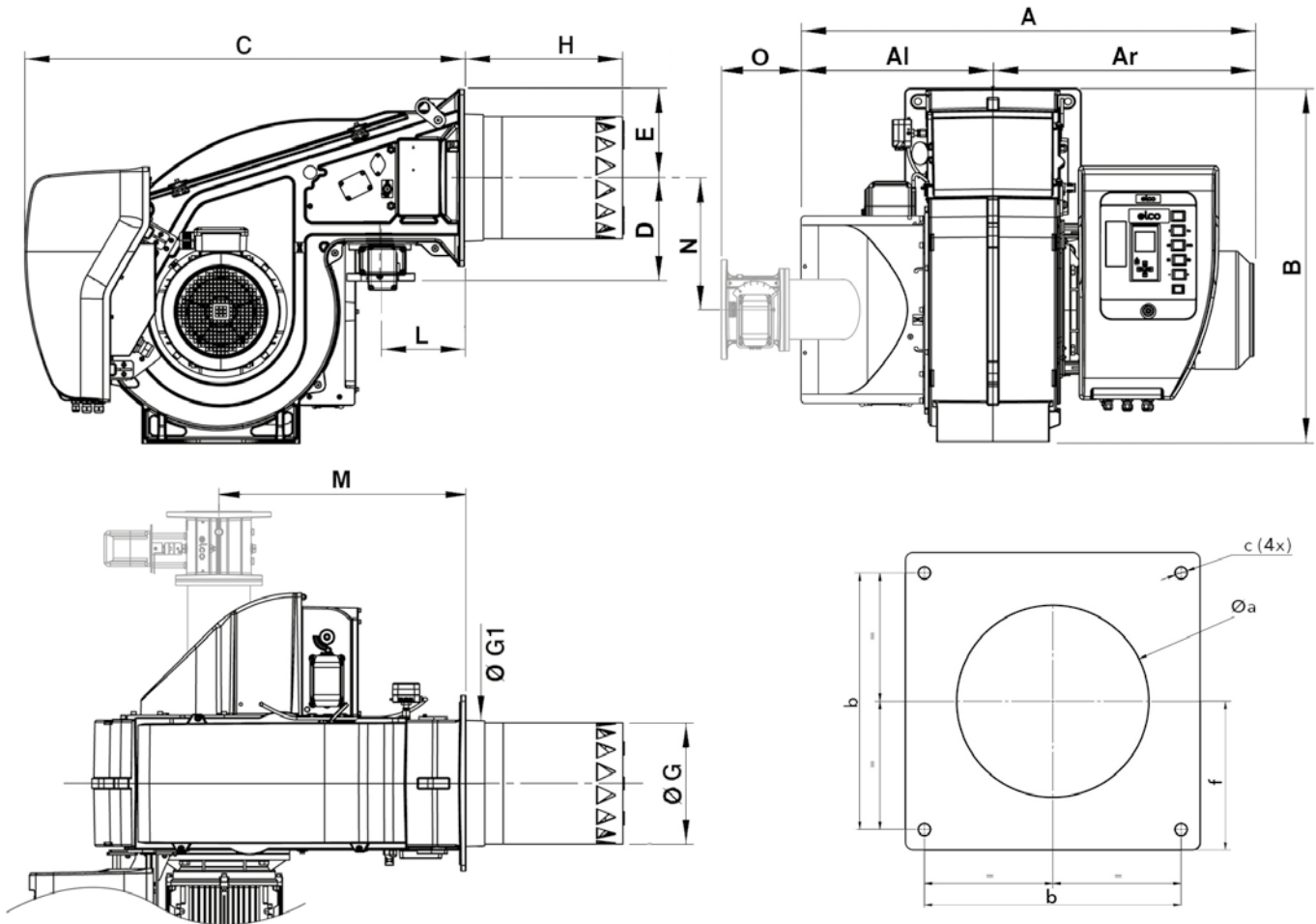

Model	A	Al	Ar	B	C	D	E	ØG	ØG1	H			L	M*	N*	O*	Øa	b	c	f
										KN	KM	KL								
EKEVO 7.3600/4500	1107	510	597	941	1122	276	235	325	343	420	550	680	225	655	356	218	360-400	400	M16	235
EKEVO 7.5800	1205	510	695	941	1168	276	235	325	343	420	550	680	225	655	356	255	360-400	400	M16	235

*: in FGR configuration

PACKAGING

The burner is delivered on a pallet with:

- burner body with mounted combustion head
- gas train and filter
- boiler fixing accessories
- technical documentation

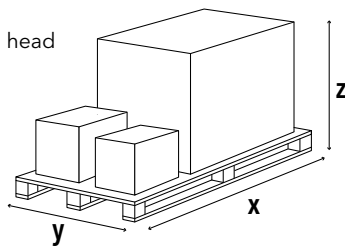

Model	Dimensions (mm)			Gross weight (kg)
	X	Y	Z	
EKEVO 7.3600 G-EU2	2046	1414	1233	350
EKEVO 7.4500 G-EU2	2046	1414	1233	350
EKEVO 7.5800 G-EU2	2046	1414	1233	350

EKEVO 7 G-EU2

630 ... 5850 kW

Two stage progressive/modulating electronic

PRESSURE LOSS [BURNER HEAD + GAS TRAIN] (mbar)

EK EVO 7.3600 G-EU2

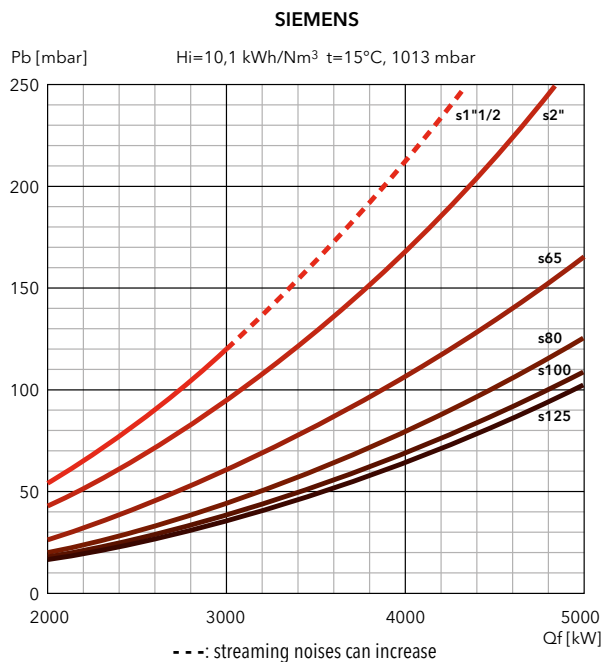
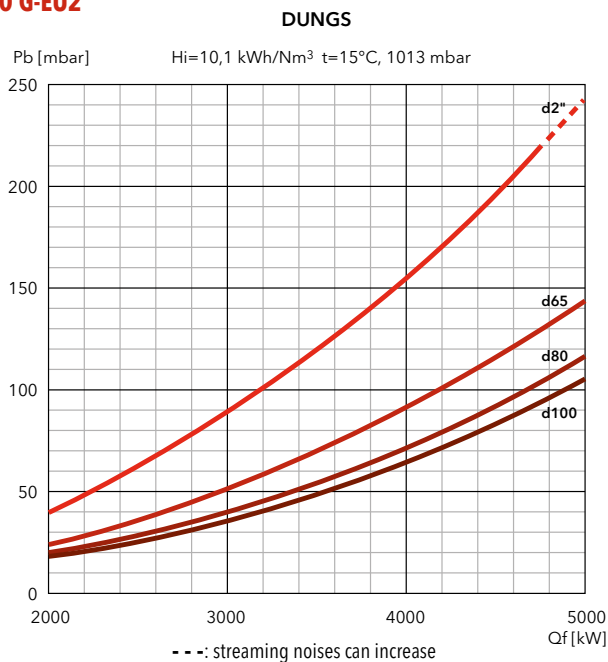

EK EVO 7.4500 G-EU2

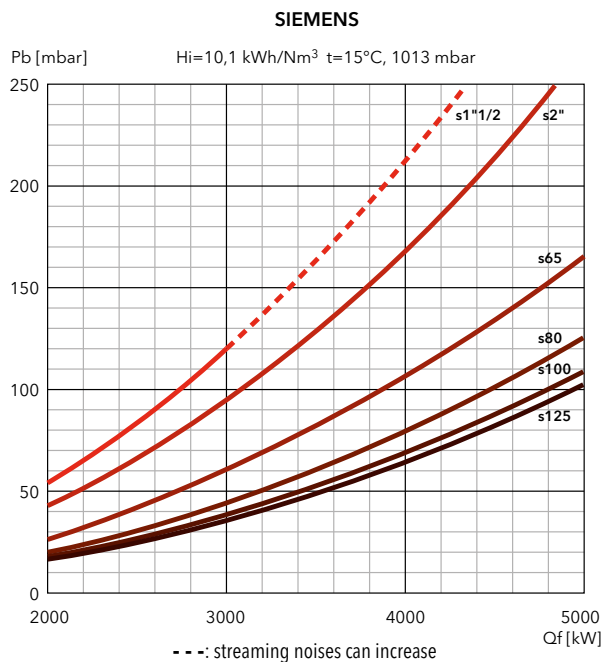
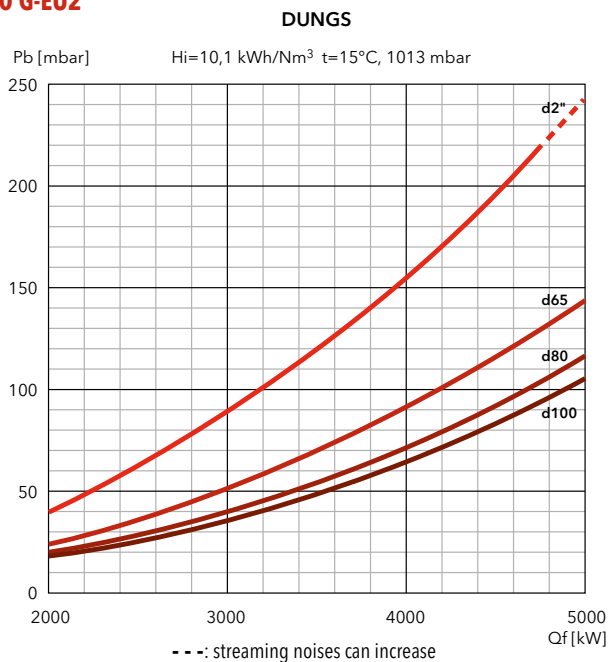

FILTERS

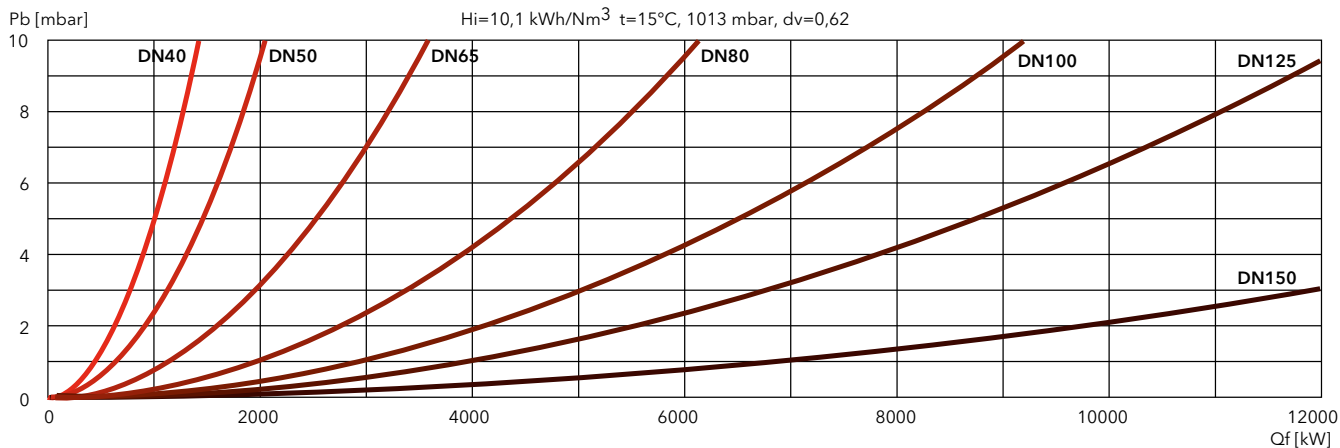



PRESSURE LOSS [BURNER HEAD + GAS TRAIN] (mbar)

EK EVO 7.5800 G-EU2

DUNGS

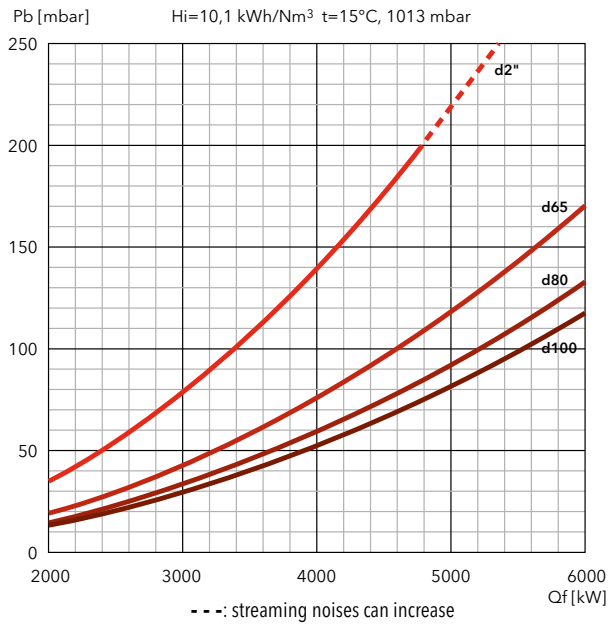

SIEMENS

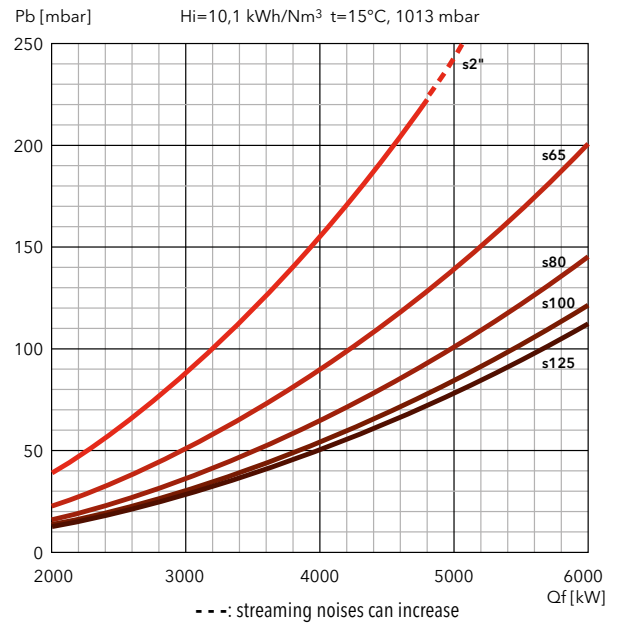

FILTERS

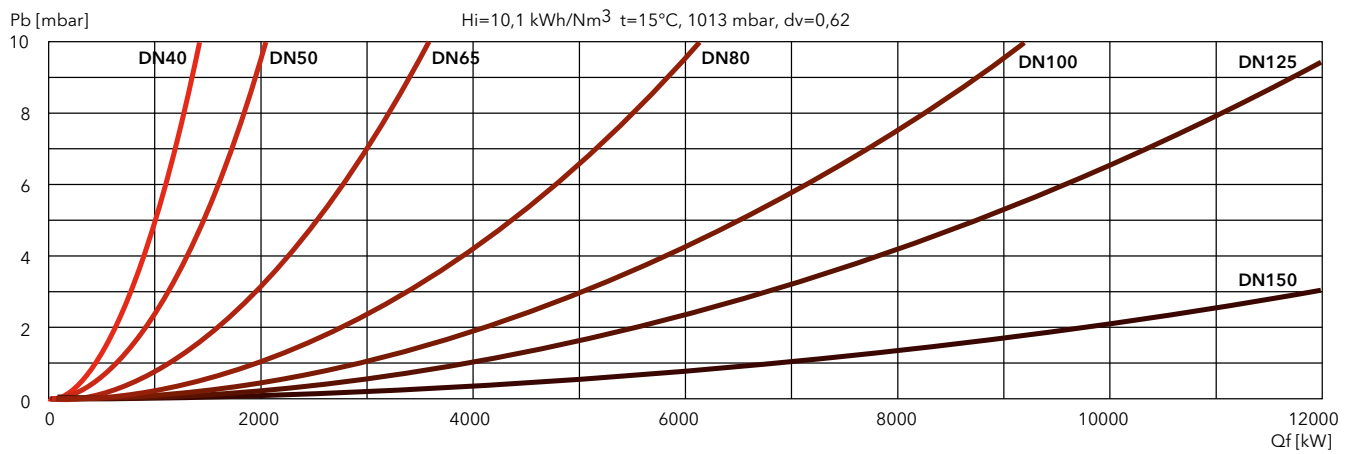

EKEVO 9 G-EU2N

1050 ... 8300 kW

Two stage progressive/modulating electronic



- **Fuels:** natural gas, Hi = 6,99 ... 11,39 kWh/Nm³;
LPG, Hi = 25,89 kWh/Nm³
- **Emission class:** Low NOx class 3 (≤80 mg/kWh) according to EN676
- **Protection level:** IP 41

TECHNICAL DATA

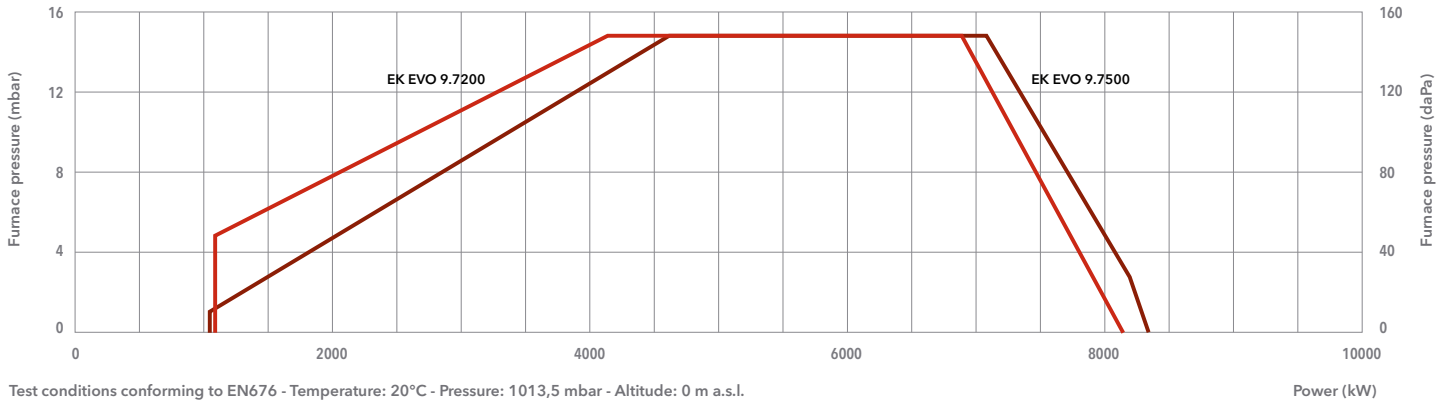

Test conditions conforming to EN676 - Temperature: 20°C - Pressure: 1013,5 mbar - Altitude: 0 m a.s.l.

	EK EVO 9.7200 G-EU2N	EK EVO 9.7500 G-EU2N
Operating range	1070 - 8020 kW	1050 - 8300 kW
Gas pressure	150 - 500 mbar	120 - 500 mbar
Gas connection	DN100	DN100
Control box / flame detector	BT300 / QRA 2	BT300 / QRA 2
Auxiliary voltage	1NPE AC 230 V - 50 Hz TN-S	1NPE AC 230 V - 50 Hz TN-S
Power supply	3PE AC 400 V - 50 Hz	3PE AC 400 V - 50 Hz
Fan motor	50 Hz - 22 kW	50 Hz - 22 kW
Acoustic level	<86 dB(A)	<86 dB(A)
CE certificate	0085CL0215	0085CL0215
Burner codes (body + head)	KN	3754690
	KM	3754691
	KL	3754692
		3754700
		3754701

GAS TRAINS

DUNGS

Model	Code
GT-d457-2" (*)	3750515
GT-d458-65	3750516
GT-d459-80	3750517
GT-d460-100	3750518

SIEMENS

Model	Code
GT-s458-65	3750538
GT-s459-80	3750539
GT-s460-100	3750540
GT-s461-125	3750541

FILTERS

Model	Code
FG-DN65	3757198
FG-DN80	3757201
FG-DN100	3757195
FG-DN125	3757209

*: integrated filter

i Pressure drops graphs: see following pages
 Dimensions of gas trains and gas filters: see page 311



DIMENSIONS (mm)

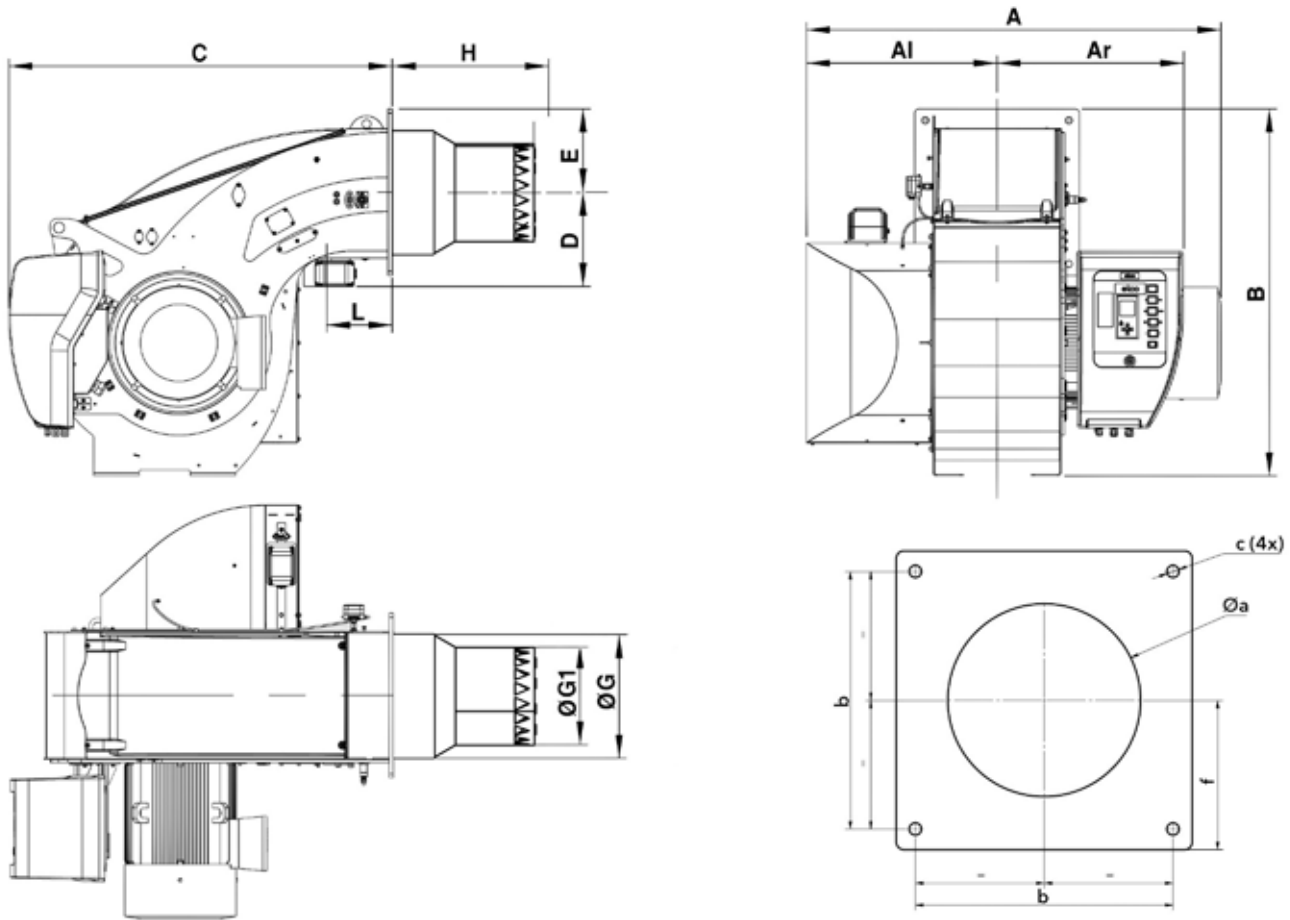

Model	A	Al	Ar	B	C	D	E	ØG	ØG1	H			L	Øa	b	c	f
										KN	KM	KL					
EK EVO 9.7200 G-EU2N	1400	670	653	1291	1353	332	293	439	346	500	640	780	230	460-480	505	M20	293
EK EVO 9.7500 G-EU2N	1400	670	653	1291	1353	332	293	439	369	550	700	850	230	460-480	505	M20	293

PACKAGING

The burner is delivered on a pallet with:

- burner body with mounted combustion head
- gas train and filter
- boiler fixing accessories
- technical documentation

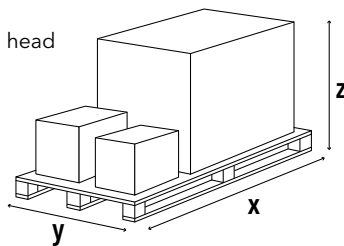

Model	Dimensions (mm)			Gross weight (kg)
	X	Y	Z	
EK EVO 9.7200 G-EU2N	2300	1500	1573	700
EK EVO 9.7500 G-EU2N	2300	1500	1573	700

EKEVO 9 G-EU2N

1050 ... 8300 kW

Two stage progressive/modulating electronic

PRESSURE LOSS [BURNER HEAD + GAS TRAIN] (mbar)

EKEVO 9.7200 G-EU2N

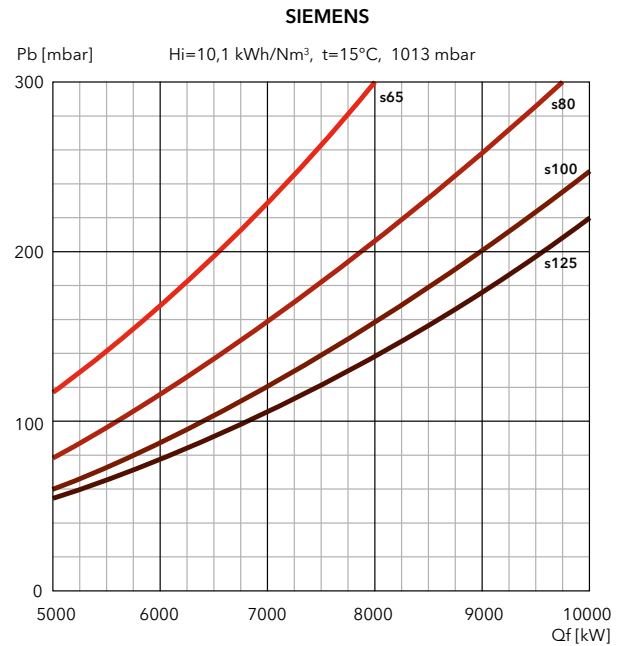
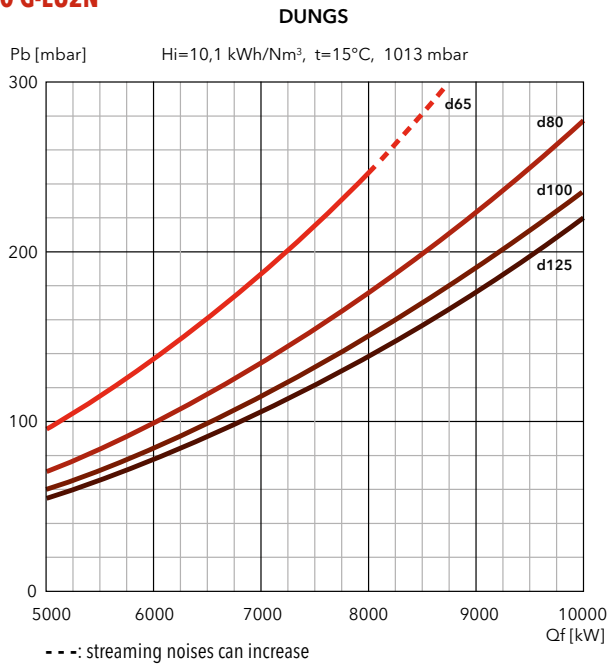

FILTERS

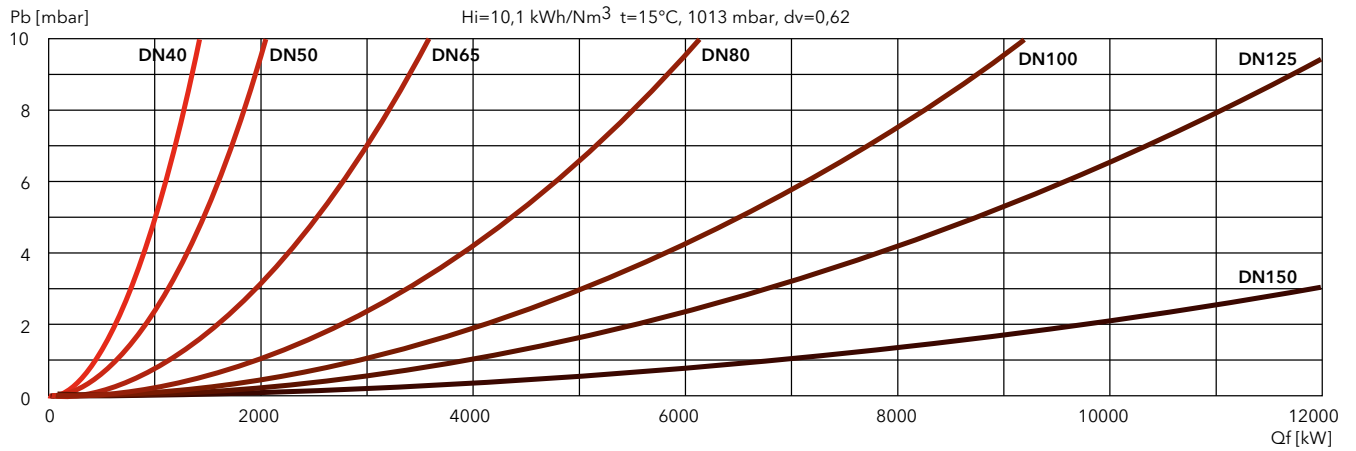



PRESSURE LOSS [BURNER HEAD + GAS TRAIN] (mbar)

EK EVO 9.7500 G-EU2N

DUNGS

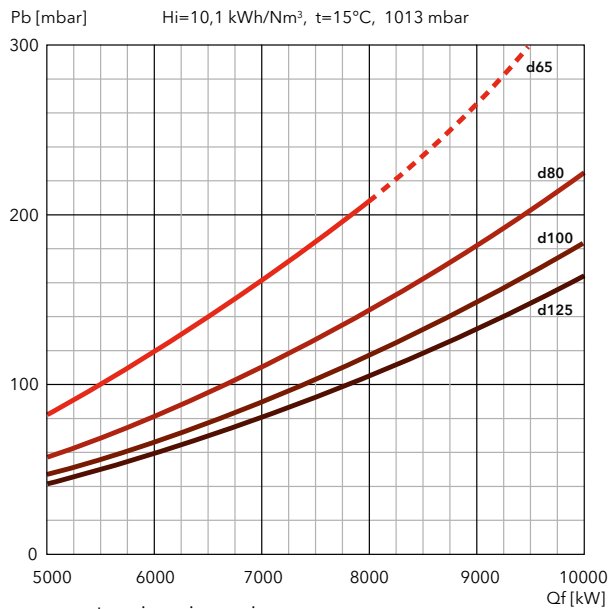

SIEMENS

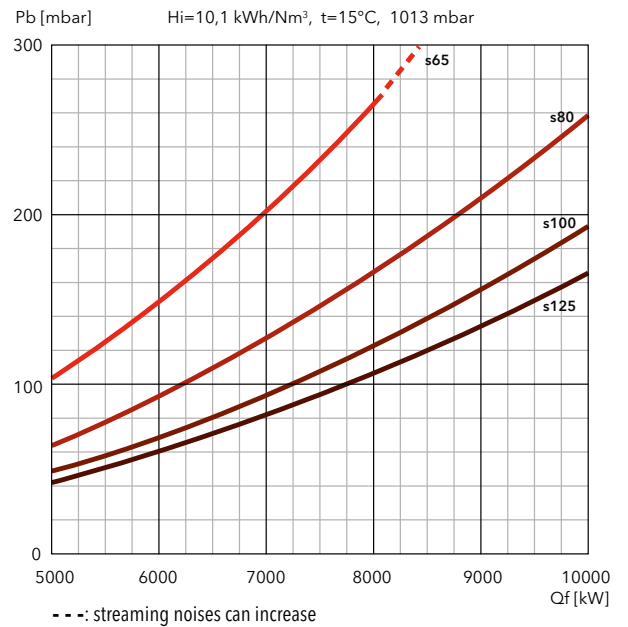

FILTERS

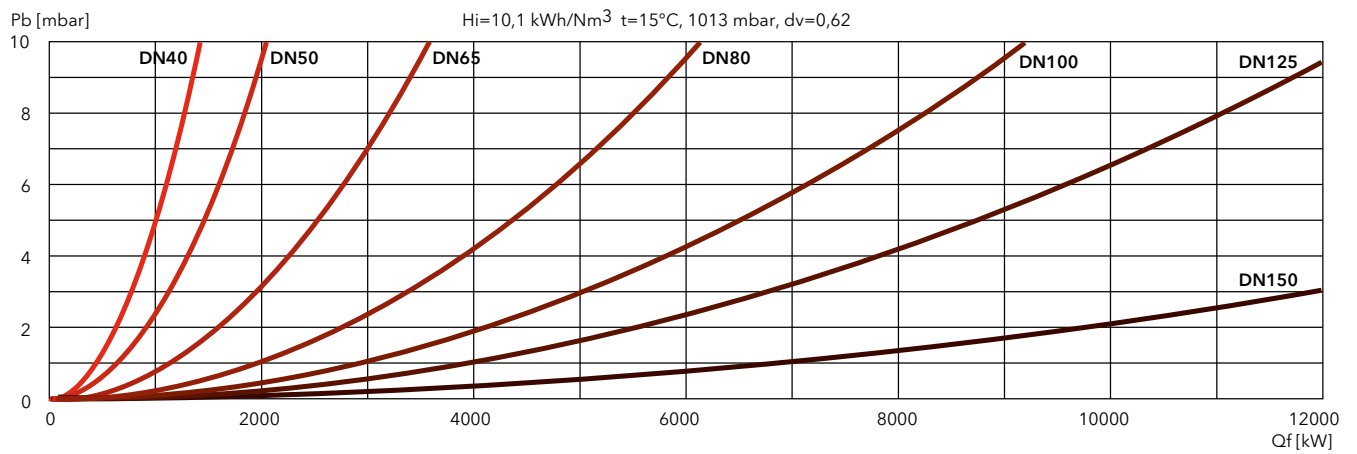

EKEVO 9 G-EU2

1700 ... 13000 kW

Two stage progressive/modulating electronic



- **Fuels:** natural gas, Hi = 6,99 ... 11,39 kWh/Nm³;
LPG, Hi = 25,89 kWh/Nm³
- **Emission class:** Low NOx class 3 (≤80 mg/kWh) according to EN676
- **Additional configuration:** models with FGR System (≤30 mg/kWh) available on request
- **Protection level:** IP 41

TECHNICAL DATA

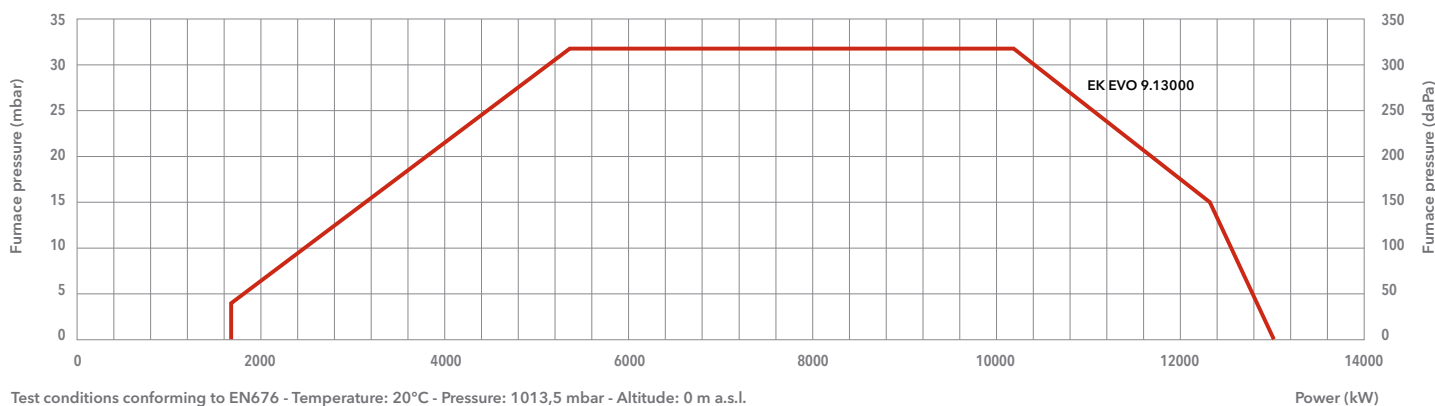

Test conditions conforming to EN676 - Temperature: 20°C - Pressure: 1013,5 mbar - Altitude: 0 m a.s.l.

		EKEVO 9.13000 G-EU2
Operating range		1700 - 13000 kW
Gas pressure		170 - 500 mbar
Gas connection		DN100
Control box / flame detector		BT300 / QRA2
Auxiliary voltage		1NPE AC 230 V - 50/60 Hz
Power supply		3PE AC 400 V - 50 Hz
Fan motor		50 Hz - 37 kW
Acoustic level		<92 dB(A)
CE certificate		0085CL0215
Burner codes (body + head)	KN	3755498
	KM	3755499
	KL	3755500

GAS TRAINS

DUNGS

Model	Code
GT-d459-80	3750517
GT-d460-100	3750518
GT-d125	on request

SIEMENS

Model	Code
GT-s459-80	3750539
GT-s460-100	3750540
GT-s461-125	3750541
GT-s150	on request

FILTERS

Model	Code
FG-DN80	3757201
FG-DN100	3757195
FG-DN125	3757209
FG-DN150	3757210

i Pressure drops graphs: see following pages
Dimensions of gas trains and gas filters: see page 311



DIMENSIONS (mm)

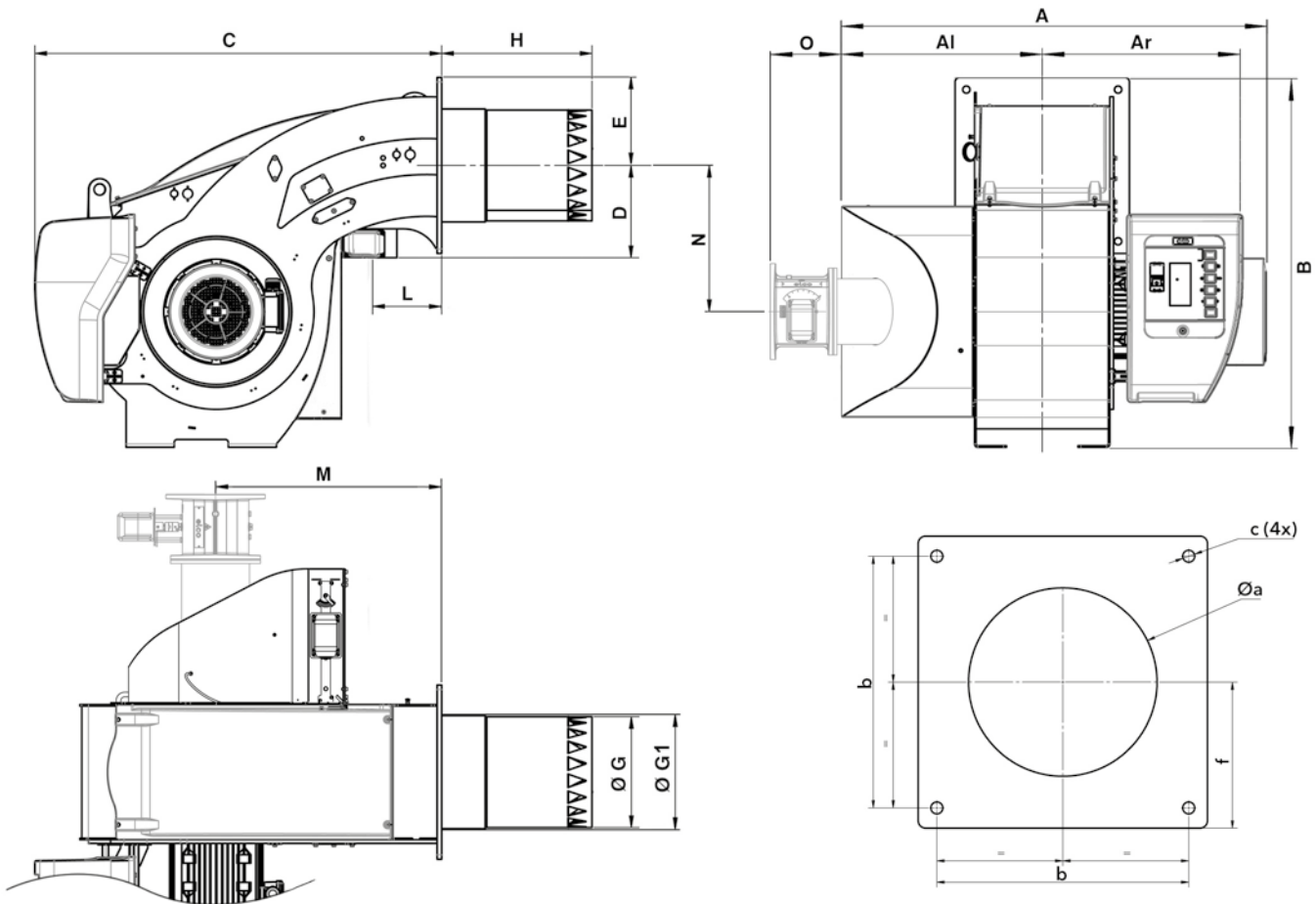

Model	A	Al	Ar	B	C	D	E	ØG	ØG1	H			L	M*	N*	O*	Øa	b	c	f
										KN	KM	KL								
EK EVO 9.13000 G-EU2	1457	670	788	1291	1348	332	293	431,5	439	550	700	850	230	750	530	291	460-480	505	M20	293

*: in FGR configuration

PACKAGING

The burner is delivered on a pallet with:

- burner body with mounted combustion head
- gas train and filter
- boiler fixing accessories
- technical documentation

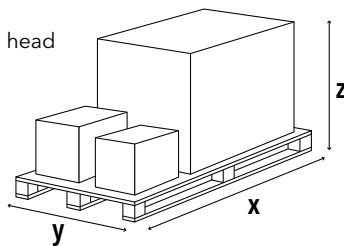

Model	Dimensions (mm)			Gross weight (kg)
	X	Y	Z	
EK EVO 9.13000 G-EU2	2300	1500	1573	700

EKEVO 9 G-EU2

1700 ... 13000 kW

Two stage progressive/modulating electronic

PRESSURE LOSS [BURNER HEAD + GAS TRAIN] (mbar)

EK EVO 9.13000 G-EU2

DUNGS

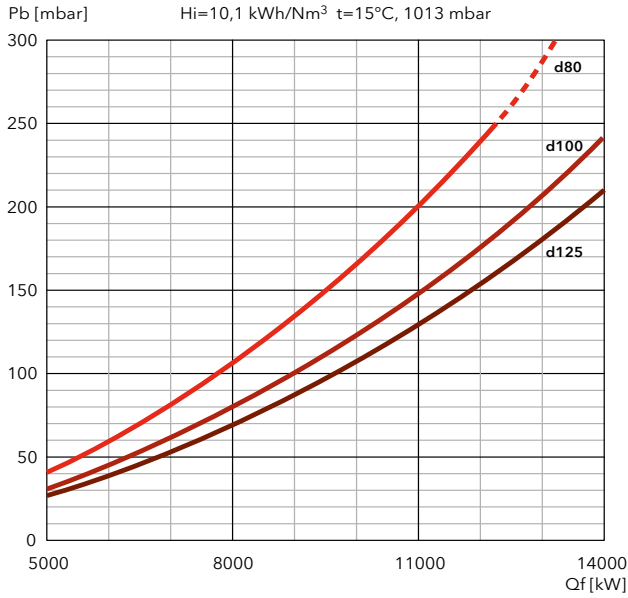

SIEMENS

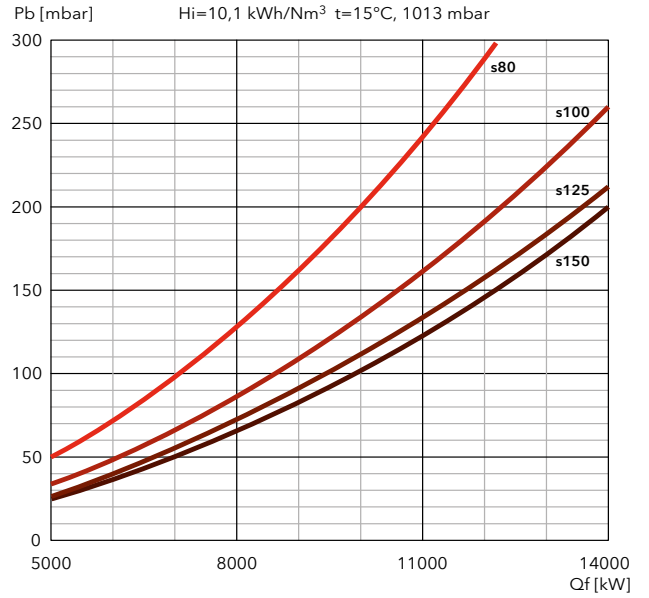



PRESSURE LOSS [BURNER HEAD + GAS TRAIN] (mbar)

FILTERS

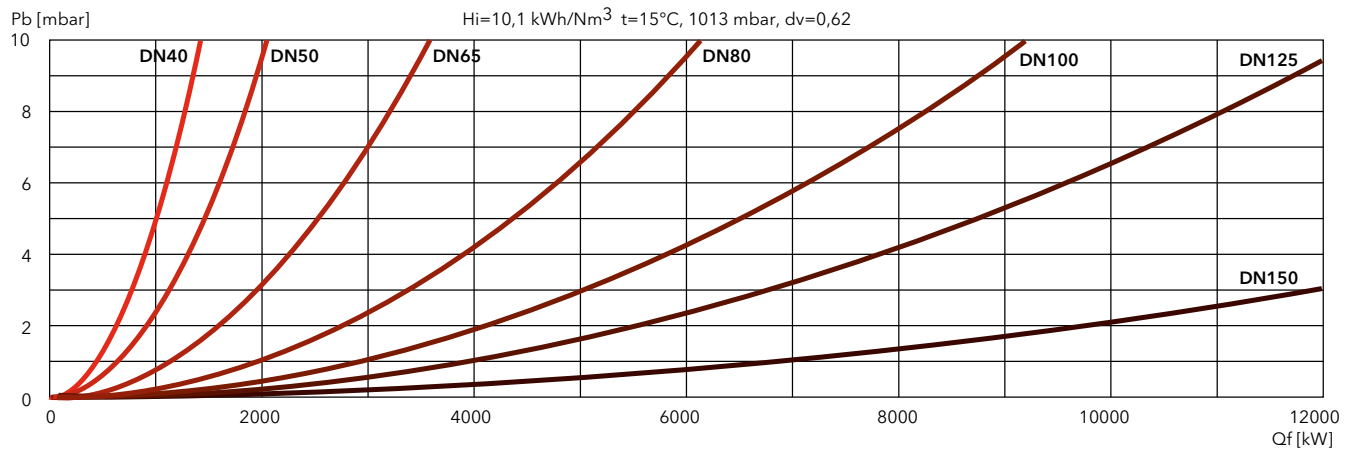

EKEVO 6 G-E / EKEVO 7 G-E

390 ... 5400 kW

Two stage progressive/modulating electronic



- **Fuels:** natural gas, Hi = 6,99 ... 11,39 kWh/Nm³;
LPG, Hi = 25,89 kWh/Nm³
- **Emission class:** Low NOx class 2 (≤120 mg/kWh) according to EN676
- **Protection level:** IP 41

TECHNICAL DATA

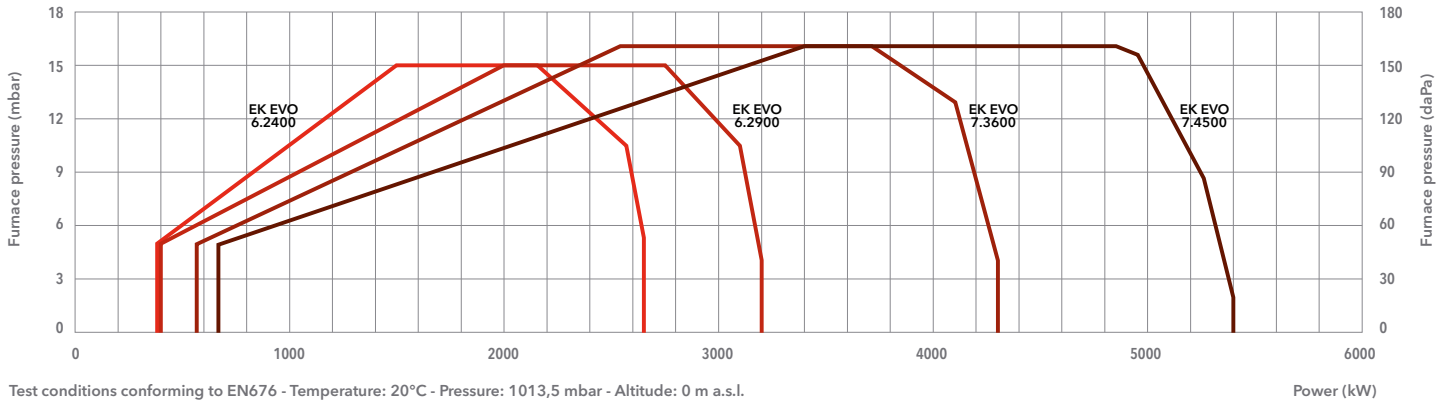

Test conditions conforming to EN676 - Temperature: 20°C - Pressure: 1013,5 mbar - Altitude: 0 m a.s.l.

	EKEVO 6.2400 G-E	EKEVO 6.2900 G-E	EKEVO 7.3600 G-E	EKEVO 7.4500 G-E
Operating range	390 - 2650 kW	400 - 3200 kW	580 - 4300 kW	680 - 5400 kW
Gas pressure	50 - 500 mbar (max 360 mbar for d452 and d453 gas train)	55 - 500 mbar (max 360 mbar for d452 and d453 gas train)	60 - 500 mbar (max 360 mbar for d452 and d453 gas train)	65 - 500 mbar (max 360 mbar for d452 and d453 gas train)
Gas connection	DN65	DN65	DN65	DN65
Control box / flame detector	BT300 / Ionisation	BT300 / Ionisation	BT300 / Ionisation	BT300 / Ionisation
Auxiliary voltage	1NPE AC 230 V - 50 Hz TN-S	1NPE AC 230 V - 50 Hz TN-S	1NPE AC 230 V - 50 Hz TN-S	1NPE AC 230 V - 50 Hz TN-S
Power supply	3PE AC 400 V - 50 Hz	3PE AC 400 V - 50 Hz	3PE AC 400 V - 50 Hz	3PE AC 400 V - 50 Hz
Fan motor	50 Hz - 3 kW	50 Hz - 4 kW	50 Hz - 5,5 kW	50 Hz - 7,5 kW
Acoustic level	<75 dB(A)	<77 dB(A)	<81 dB(A)	<82,5 dB(A)
CE certificate	0085CL0215	0085CL0215	0085CL0215	0085CL0215
Burner codes (body + head)	KN	3752745	3752746	3752748
	KM	3752749	3752750	3752752
	KL	3752753	3752754	3752756

GAS TRAINS

DUNGS

Model	Code
GT-d452-1"1/2 (*)	3750510
GT-d453-2" (*)	3750511
GT-d454-65	3750512
GT-d455-80	3750513
GT-d456-100	3750514

SIEMENS

Model	Code
GT-s451-1"1/2	3750525
GT-s452-2"	3750526
GT-s453-65	3750527
GT-s454-80	3750528
GT-s455-100	3750529
GT-s456-125	3750530

FILTERS

Model	Code
FG-Rp1"1/2	3757199
FG-Rp2"	3757200
FG-DN65	3757198
FG-DN80	3757201
FG-DN100	3757195
FG-DN125	3757209

*: integrated filter

i **Pressure drops graphs:** see following pages
Dimensions of gas trains and gas filters: see page 310



DIMENSIONS (mm)

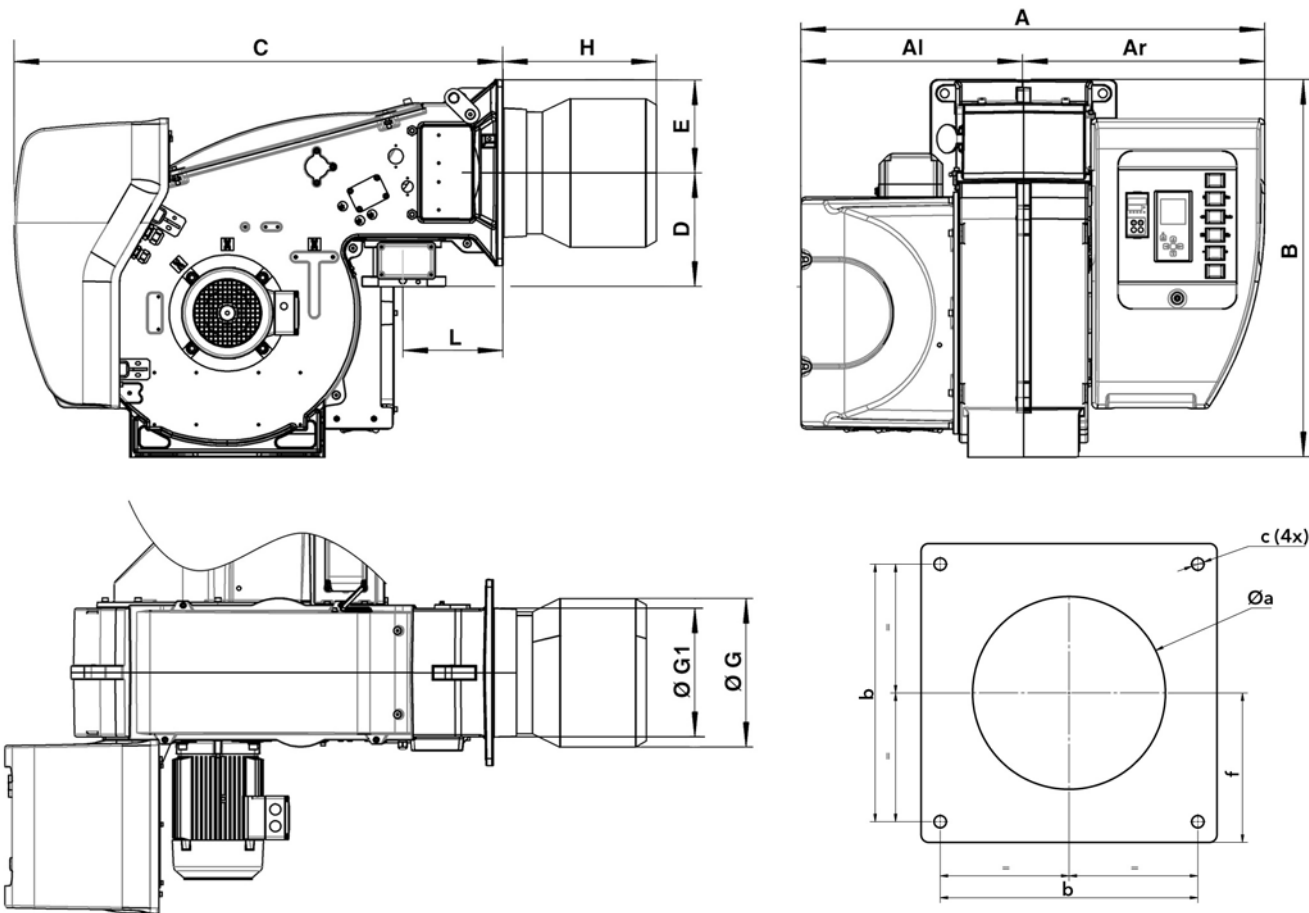

Model	A	Al	Ar	B	C	D	E	ØG	ØG1	H			L	Øa	b	c	f
										KN	KM	KL					
EKEVO 6... G-E	1035	479	556	812	1054	245	200	320	277	330	450	570	215	330-340	340	M16	200
EKEVO 7... G-E	1096	510	597	941	1120	276	235	368	338,5	375	505	635	225	380-400	400	M16	235

PACKAGING

The burner is delivered on a pallet with:

- burner body with mounted combustion head
- gas train and filter
- boiler fixing accessories
- technical documentation

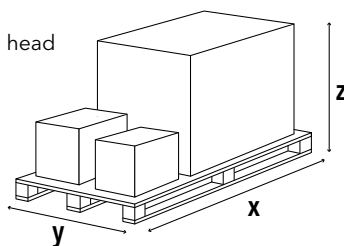

Model	Dimensions (mm)			Gross weight (kg)
	X	Y	Z	
EK EVO 6.2400 G-E	2046	1414	1233	300
EK EVO 6.2900 G-E	2046	1414	1233	300
EK EVO 7.3600 G-E	2046	1414	1233	350
EK EVO 7.4500 G-E	2046	1414	1233	350

EKEVO 6 G-E / EKEVO 7 G-E

390 ... 5400 kW

Two stage progressive/modulating electronic

PRESSURE LOSS [BURNER HEAD + GAS TRAIN] (mbar)

EKEVO 6.2400 G-E

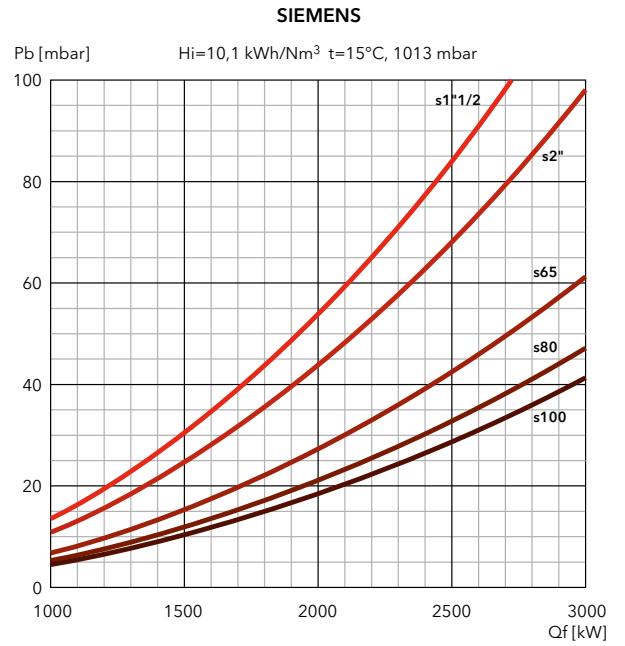
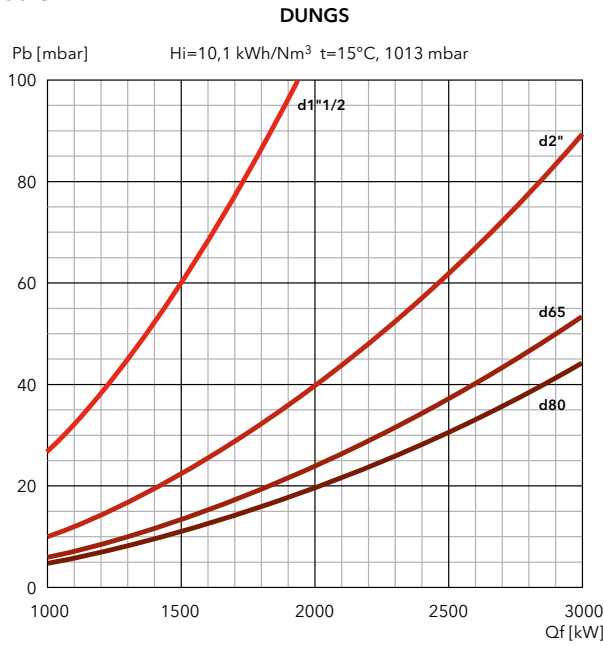

EKEVO 6.2900 G-E

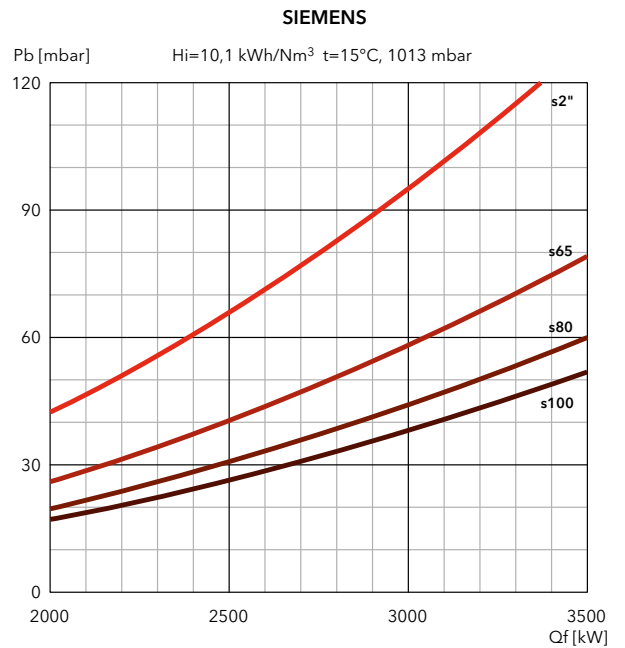
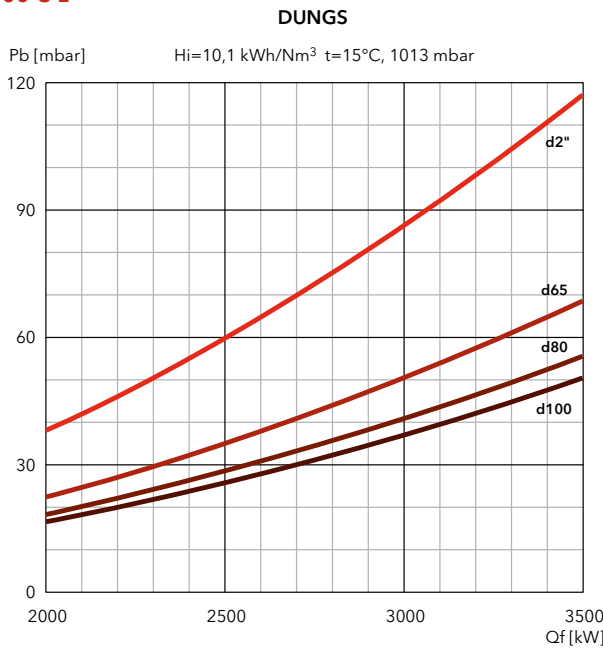

FILTERS

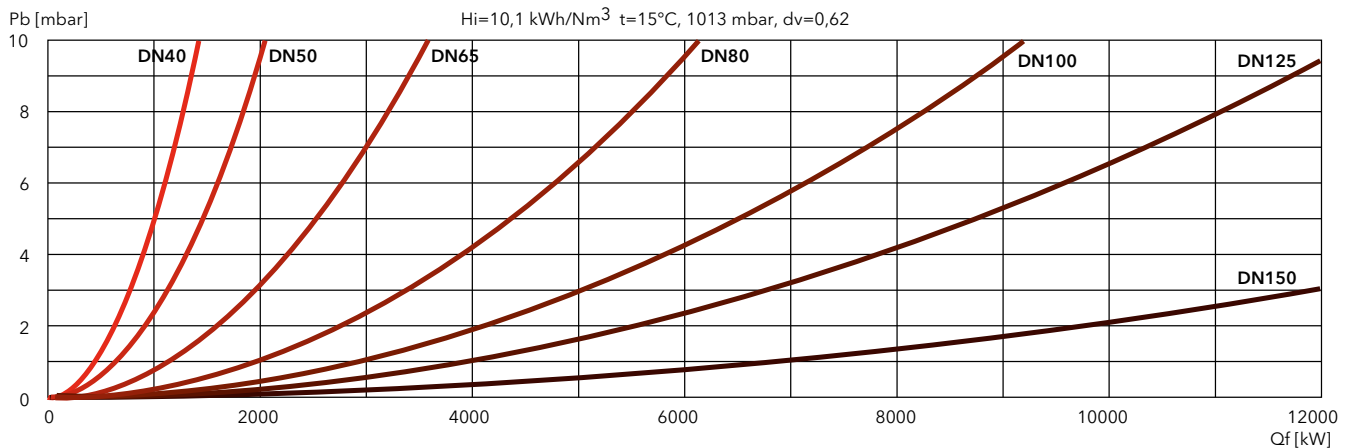



PRESSURE LOSS [BURNER HEAD + GAS TRAIN] (mbar)

EK EVO 7.3600 G-E

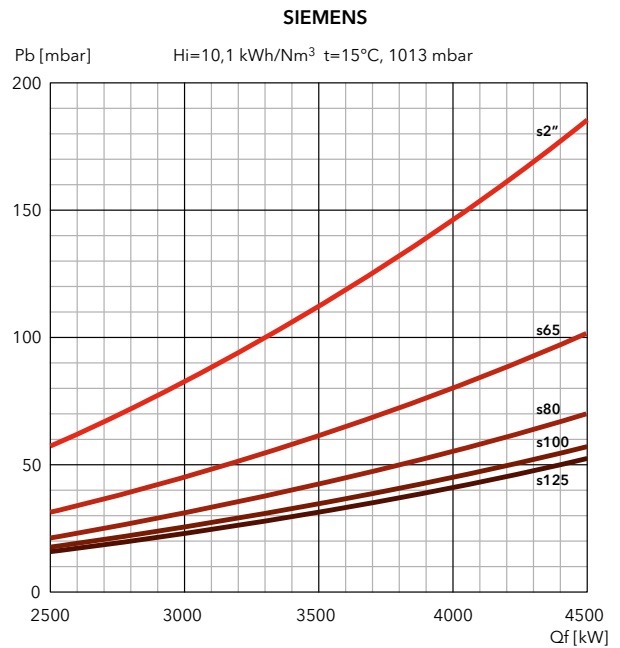
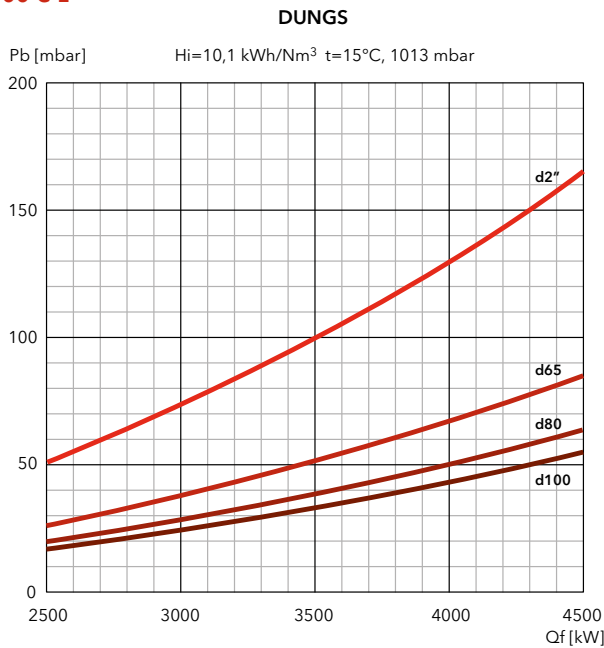

EK EVO 7.4500 G-E

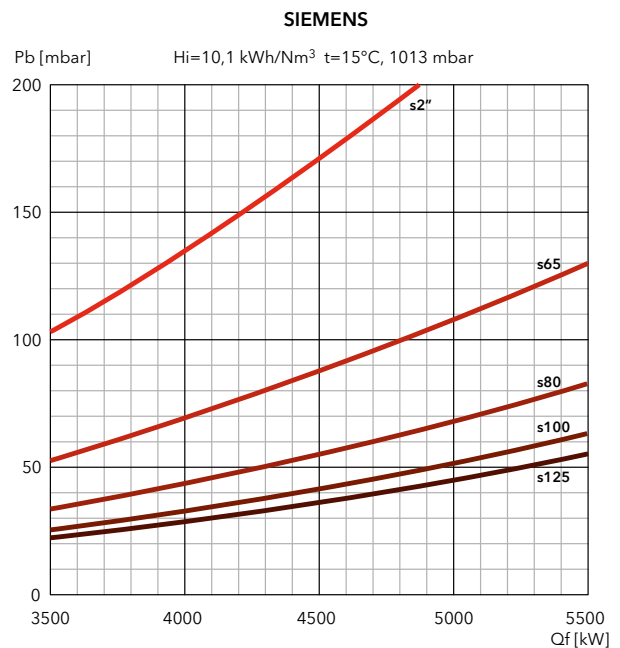
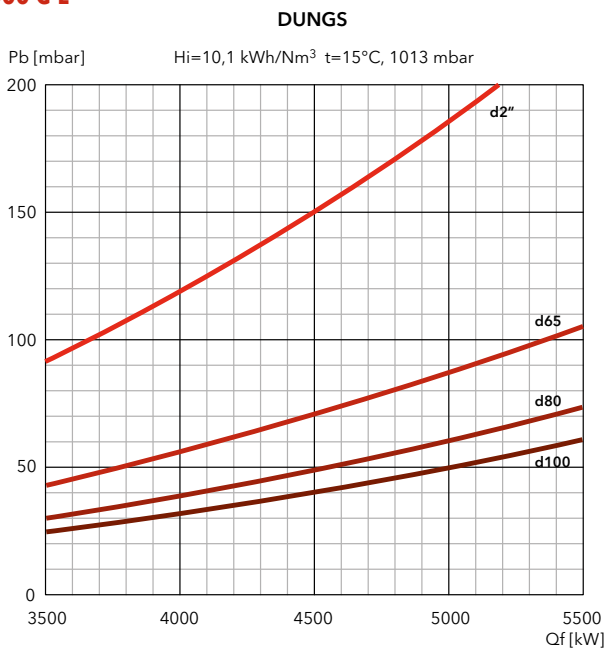

FILTERS

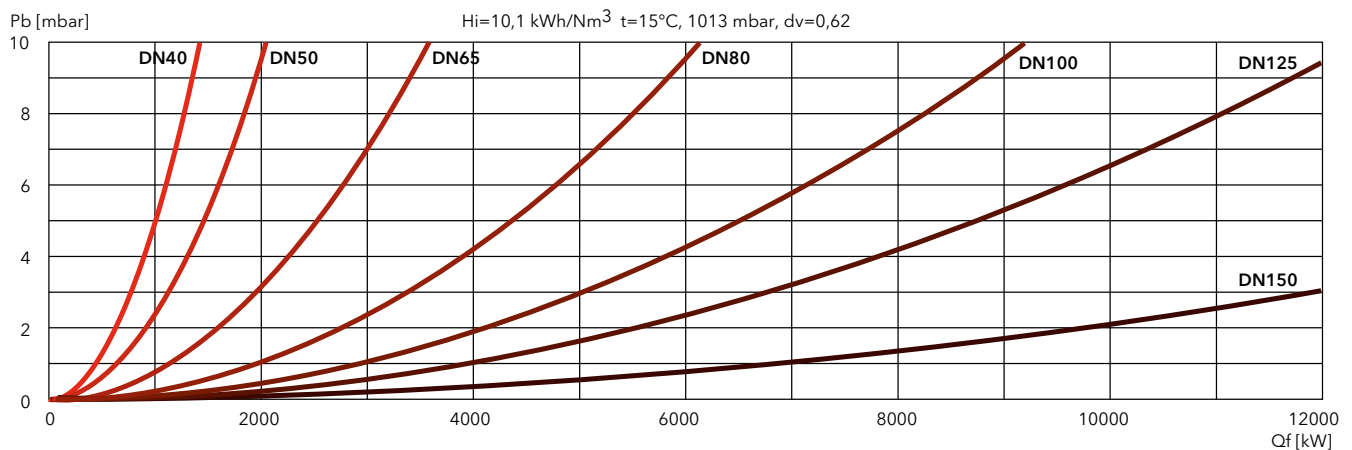

EKEVO 8 G-E / EKEVO 9 G-E

610 ... 11230 kW

Two stage progressive/modulating electronic



- **Fuels:** natural gas, Hi = 6,99 ... 11,39 kWh/Nm³;
LPG, Hi = 25,89 kWh/Nm³
- **Emission class:** Low NOx class 2 (≤120 mg/kWh) according to EN676
- **Modulating ratio:** 1:10
- **Protection level:** IP 41

TECHNICAL DATA

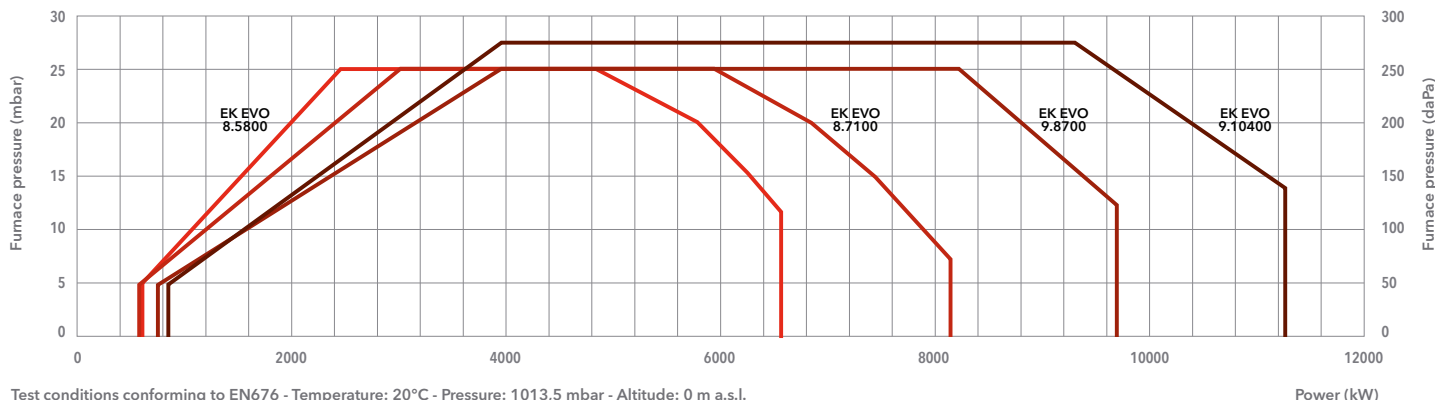

	EKEVO 8.5800 G-E	EKEVO 8.7100 G-E	EKEVO 9.8700 G-E	EKEVO 9.10400 G-E
Operating range	620 – 6570 kW	610 – 8150 kW	780 – 9700 kW	850 – 11230 kW
Gas pressure	60 – 500 mbar (60 – 360 mbar for d457)		70 – 500 mbar (70 – 360 mbar for d457)	
Gas connection	DN100	DN100	DN100	DN100
Control box / flame detector	BT300 / Ionisation	BT300 / Ionisation	BT300 / Ionisation	BT300 / Ionisation
Auxiliary voltage	1NPE AC 230 V – 50 Hz TN-S	1NPE AC 230 V – 50 Hz TN-S	1NPE AC 230 V – 50 Hz TN-S	1NPE AC 230 V – 50 Hz TN-S
Power supply	3PE AC 400 V – 50 Hz	3PE AC 400 V – 50 Hz	3PE AC 400 V – 50 Hz	3PE AC 400 V – 50 Hz
Fan motor	50 Hz – 11 kW	50 Hz – 15 kW	50 Hz – 18,5 kW	50 Hz – 22 kW
Acoustic level	<80,3 dB(A)	<81 dB(A)	<84,8 dB(A)	<86,3 dB(A)
CE certificate	0085CL0215	0085CL0215	0085CL0215	0085CL0215
Burner codes (body + head)	KN	3753965	3753966	3753967
	KM	3753974	3753975	3753976
	KL	3753982	3753983	3753984

GAS TRAINS

DUNGS

Model	Code
GT-d457-2" (*)	3750515
GT-d458-65	3750516
GT-d459-80	3750517
GT-d460-100	3750518

SIEMENS

Model	Code
GT-s457-2"	3750537
GT-s458-65	3750538
GT-s459-80	3750539
GT-s460-100	3750540
GT-s461-125	3750541

FILTERS

Model	Code
FG-Rp2"	3757200
FG-DN65	3757198
FG-DN80	3757201
FG-DN100	3757195
FG-DN125	3757209

*: integrated filter

i **Pressure drops graphs:** see following pages
Dimensions of gas trains and gas filters: see page 311



DIMENSIONS (mm)

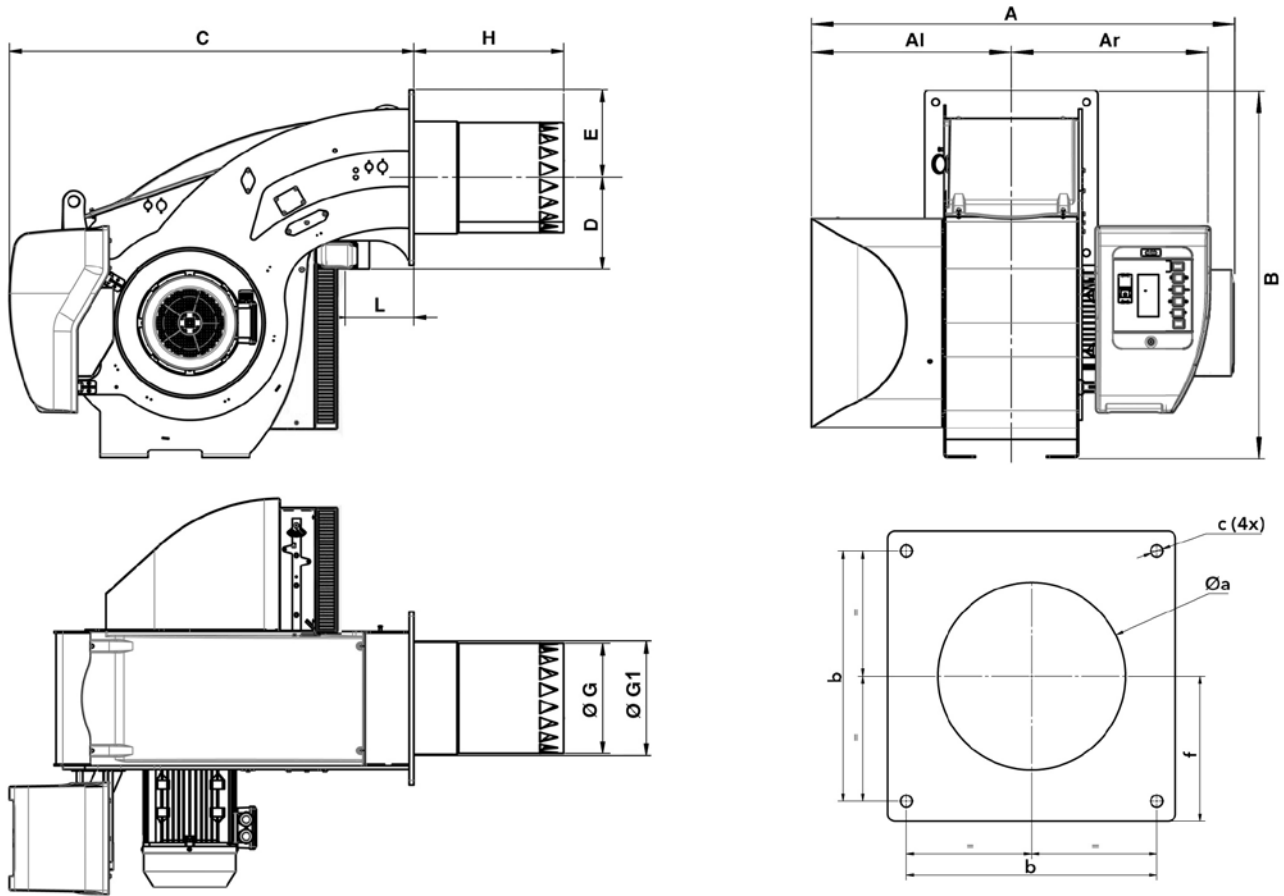

Model	A	Al	Ar	B	C	D	E	ØG	ØG1	H			L	Øa	b	c	f
										KN	KM	KL					
EK EVO 8.5800 G-E	1323	670	653	1231	1353	307	293	369	376	500	540	780	230	385-410	505	M20	293
EK EVO 8.7100 G-E	1323	670	653	1231	1353	307	293	369	376	500	540	780	230	385-410	505	M20	293
EK EVO 9.8700 G-E	1326	670	656	1291	1350	332	293	431,5	438,5	550	700	850	230	450-480	505	M20	293
EK EVO 9.10400 G-E	1326	670	656	1291	1350	332	293	431,5	438,5	550	700	850	230	450-480	505	M20	293

PACKAGING

The burner is delivered on a pallet with:

- burner body with mounted combustion head
- gas train and filter
- boiler fixing accessories
- technical documentation

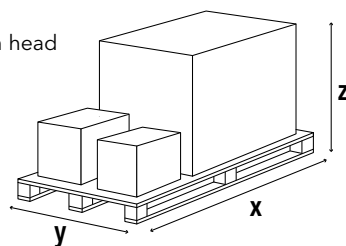

Model	Dimensions (mm)			Gross weight (kg)
	X	Y	Z	
EK EVO 8.5800 G-E	2300	1500	1573	580
EK EVO 8.7100 G-E	2300	1500	1573	580
EK EVO 9.8700 G-E	2300	1500	1573	700
EK EVO 9.10400 G-E	2300	1500	1573	700

EKEVO 8 G-E / EKEVO 9 G-E

610 ... 11230 kW

Two stage progressive/modulating electronic

PRESSURE LOSS [BURNER HEAD + GAS TRAIN] (mbar)

EKEVO 8.5800 G-E

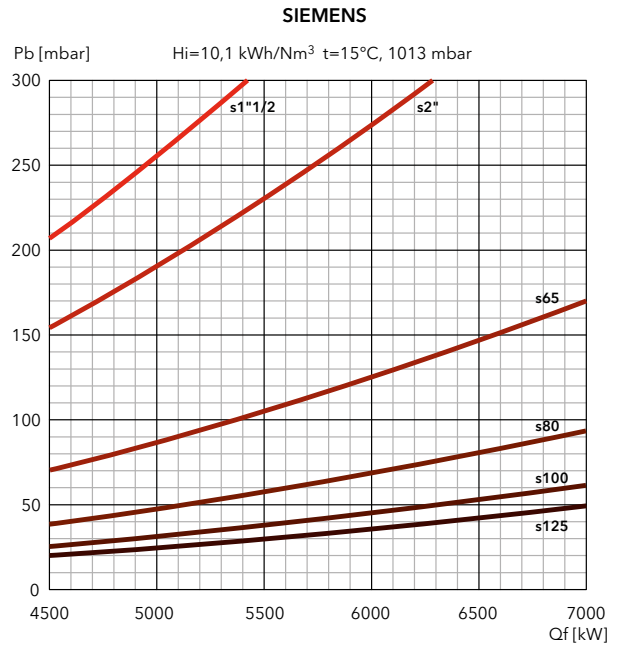
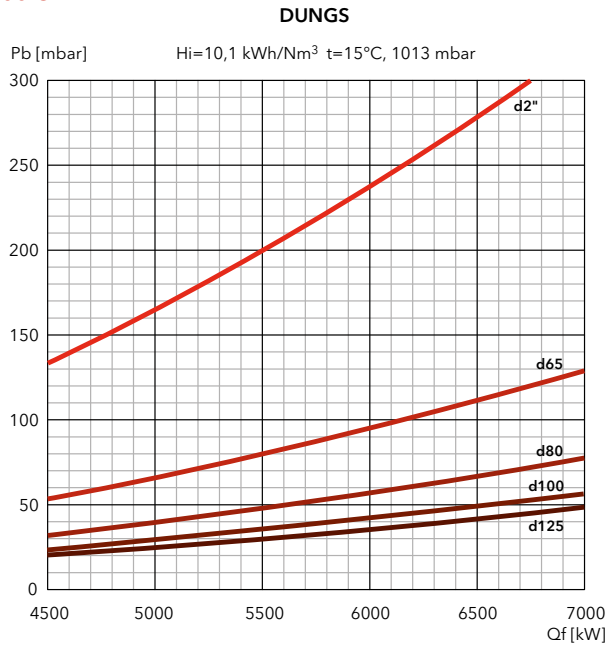

EKEVO 8.7100 G-E

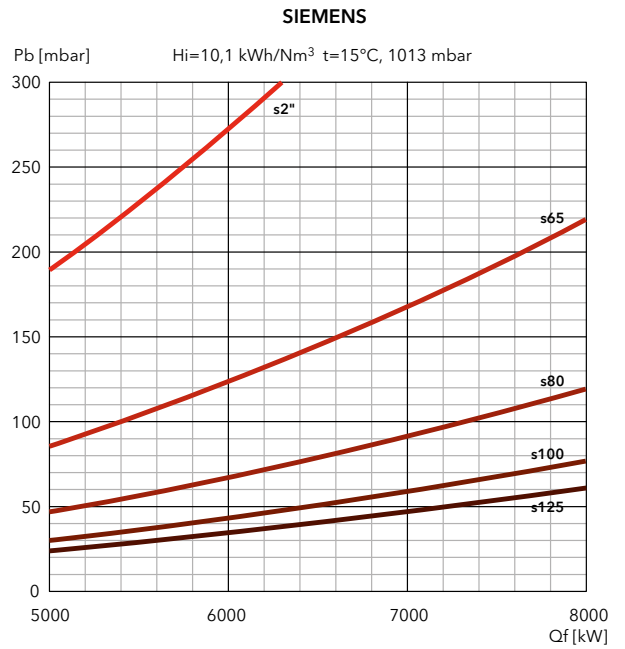
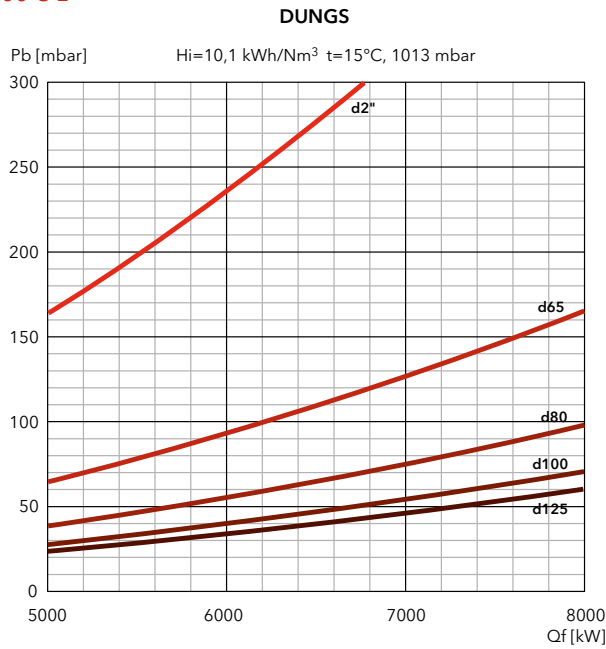

FILTERS

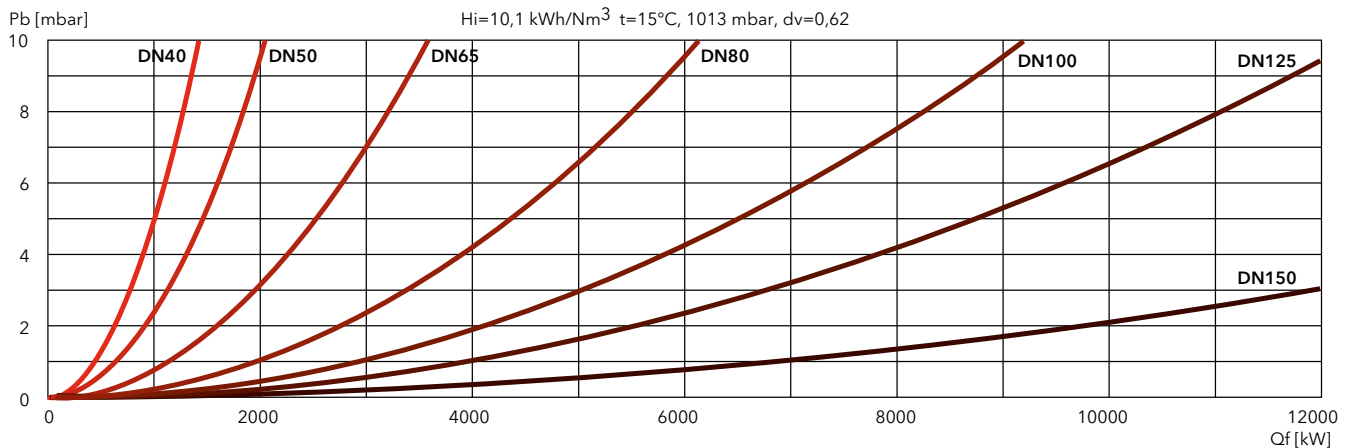



PRESSURE LOSS [BURNER HEAD + GAS TRAIN] (mbar)

EK EVO 9.8700 G-E

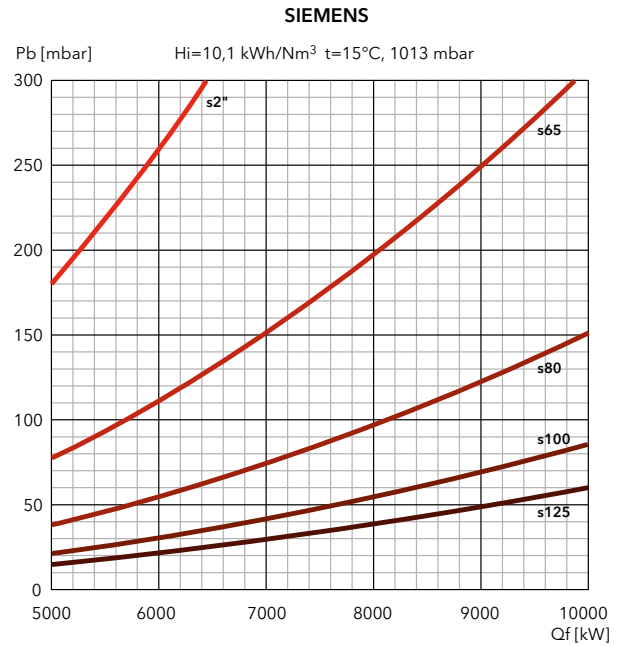
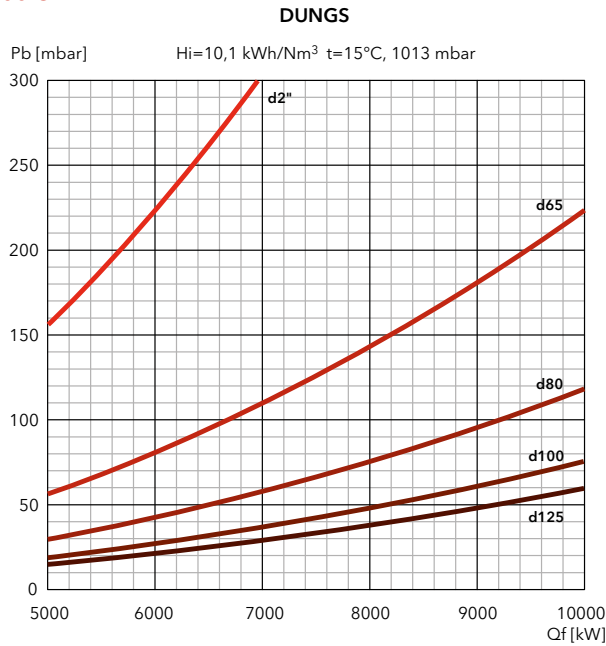

EK EVO 9.10400 G-E

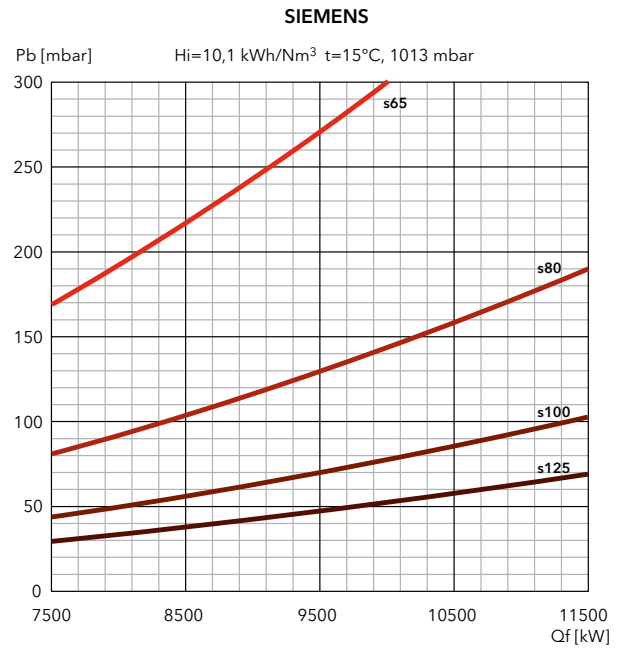
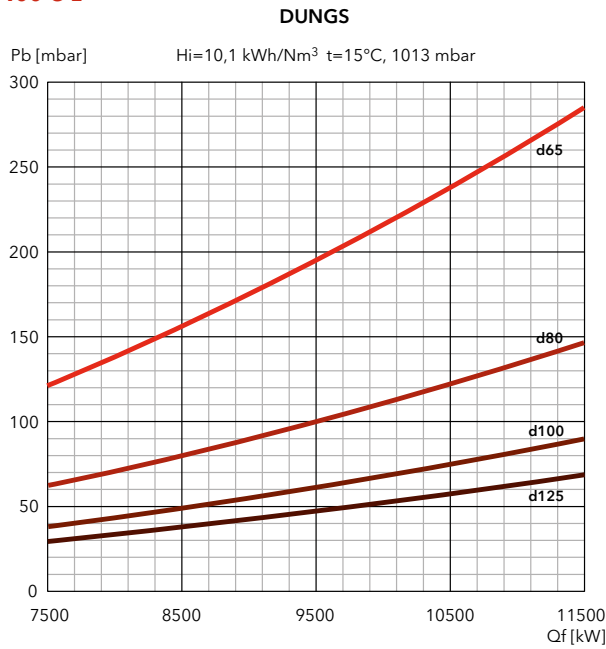

FILTERS

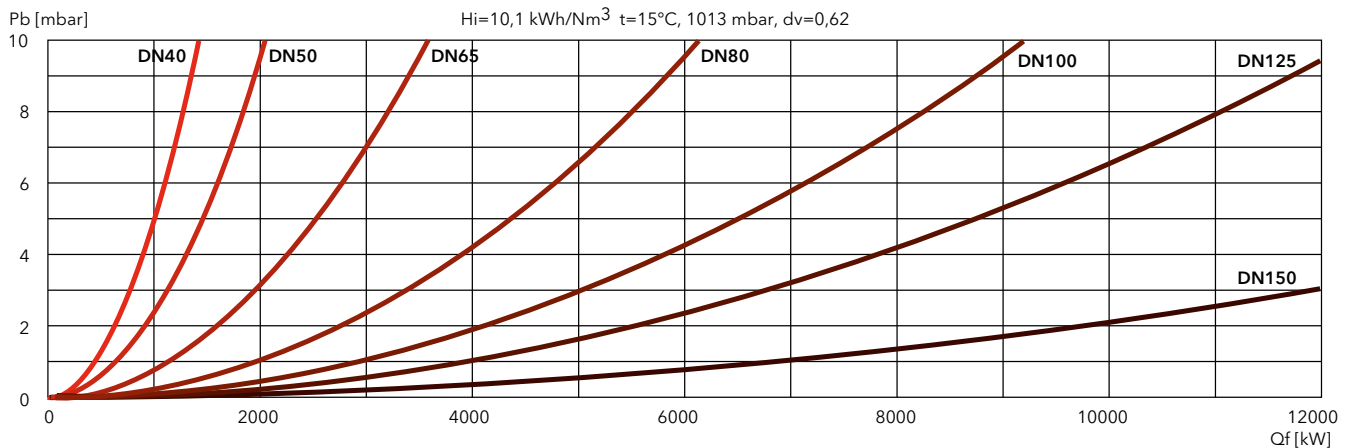

EKEVO 6 GL-EF3 / EKEVO 7 GL-EF3

280 ... 4500 kW

Two stage progressive/modulating electronic in gas and in light oil



- **Fuels:** natural gas, Hi = 6,99 ... 11,39 kWh/Nm³;
light oil, viscosity 6 mm²/s at 20°C, Hi = 11,86 kWh/kg
- **Emission class:** Low NOx class 3 (≤80 mg/kWh) according to EN676 in gas
Low NOx class 3 (≤120 mg/kWh) according to EN267 in light oil
- **Protection level:** IP 41

TECHNICAL DATA

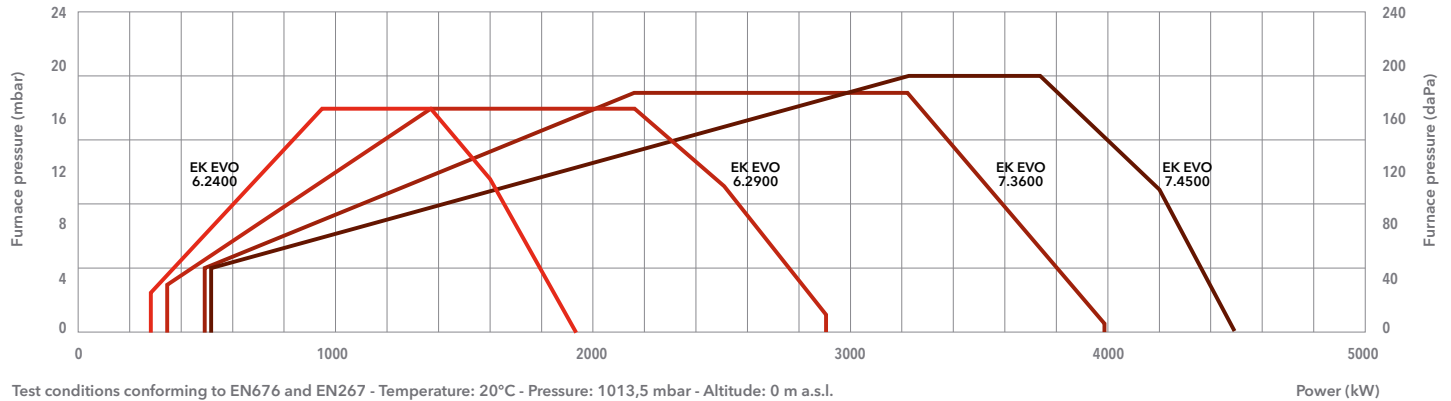

Test conditions conforming to EN676 and EN267 - Temperature: 20°C - Pressure: 1013,5 mbar - Altitude: 0 m a.s.l.

	EK EVO 6.2400 GL-EF3	EK EVO 6.2900 GL-EF3	EK EVO 7.3600 GL-EF3	EK EVO 7.4500 GL-EF3
Operating range gas	280 - 1920 kW	340 - 2890 kW	470 - 3980 kW	510 - 4500 kW
Operating range oil	360 - 1920 kW	480 - 2890 kW	680 - 3980 kW	740 - 4500 kW
Gas pressure	50 - 500 mbar (50 - 360 mbar for d452 and d453)			
Gas connection	DN65	DN65	DN65	DN65
Control box / flame detector	BT300 / FFS08	BT300 / FFS08	BT300 / FFS08	BT300 / FFS08
Auxiliary voltage	1NPE AC 230 V - 50 Hz TN-S	1NPE AC 230 V - 50 Hz TN-S	1NPE AC 230 V - 50 Hz TN-S	1NPE AC 230 V - 50 Hz TN-S
Power supply	3PE AC 400 V - 50 Hz	3PE AC 400 V - 50 Hz	3PE AC 400 V - 50 Hz	3PE AC 400 V - 50 Hz
Fan motor	50 Hz - 3 kW	50 Hz - 4 kW	50 Hz - 7,5 kW	50 Hz - 7,5 kW
Acoustic level	<76 dB(A)	<77 dB(A)	<83 dB(A)	<81 dB(A)
CE certificate	0085CL0215	0085CL0215	0085CL0215	0085CL0215
Burner codes (body + head)	KN	3754521	3754522	3754523
	KM	3754525	3754526	3754527
	KL	3754529	3754530	3754531

GAS TRAINS

DUNGS

Model	Code
GT-d452-1"1/2 (*)	3750510
GT-d453-2" (*)	3750511
GT-d454-65	3750512
GT-d455-80	3750513
GT-d456-100	3750514

*: integrated filter

SIEMENS

Model	Code
GT-s451-1"1/2	3750525
GT-s452-2"	3750526
GT-s453-65	3750527
GT-s454-80	3750528
GT-s455-100	3750529
GT-s456-125	3750530

FILTERS

Model	Code
FG-Rp1"1/2	3757199
FG-Rp2"	3757200
FG-DN65	3757198
FG-DN80	3757201
FG-DN100	3757195
FG-DN125	3757209

i Pressure drops graphs: see following pages
Dimensions of gas trains and gas filters: see page 310



DIMENSIONS (mm)

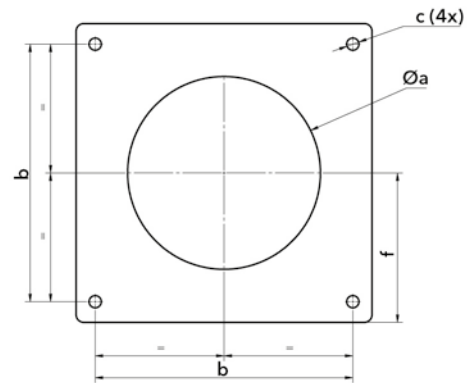
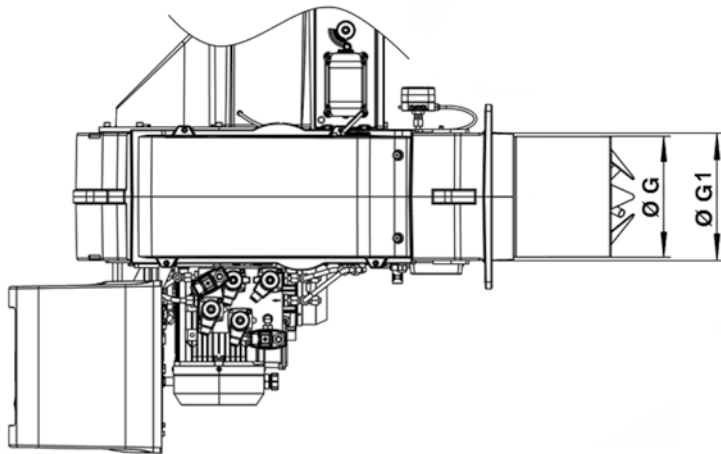
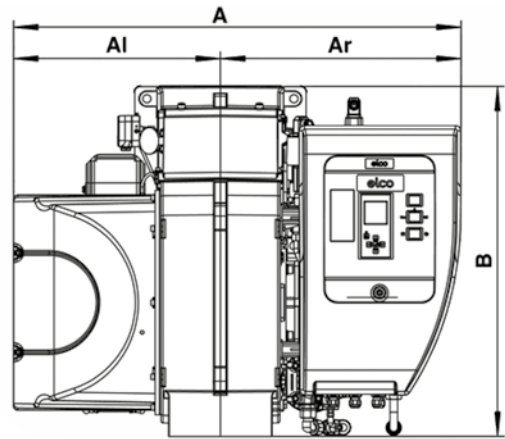
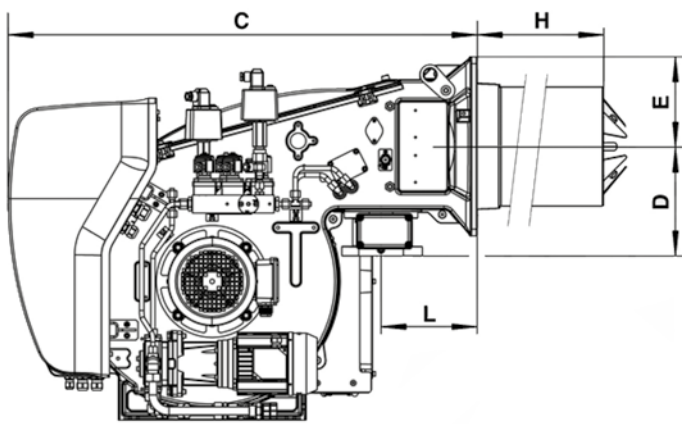

Model	A	AI	Ar	B	C	D	E	ØG	ØG1	H			L	Øa	b	c	f
										KN	KM	KL					
EKEVO 6.2400 GL-EF3	1035	479	556	812	1056	245	200	227	277	400	520	640	215	300-340	340	M16	200
EKEVO 6.2900 GL-EF3	1035	479	556	812	1056	245	200	263	277	400	520	640	215	300-340	340	M16	200
EKEVO 7.3600 GL-EF3	1107	510	597	941	1130	276	235	323.5	339	420	550	680	225	360-400	400	M16	235
EKEVO 7.4500 GL-EF3	1107	510	597	941	1130	276	235	323,5	339	420	550	680	225	360-400	400	M16	235

PACKAGING

The burner is delivered on a pallet with:

- burner body with mounted combustion head
- gas train and filter
- boiler fixing accessories
- technical documentation

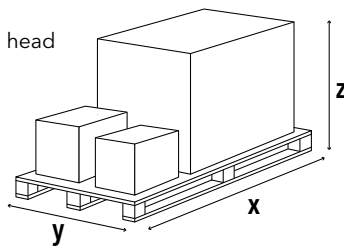

Model	Dimensions (mm)			Gross weight (kg)
	X	Y	Z	
EKEVO 6.2400 GL-EF3	2046	1414	1233	300
EKEVO 6.2900 GL-EF3	2046	1414	1233	300
EKEVO 7.3600 GL-EF3	2046	1414	1233	350
EKEVO 7.4500 GL-EF3	2046	1414	1233	350

EKEVO 6 GL-EF3 / EKEVO 7 GL-EF3

280 ... 4500 kW

Two stage progressive/modulating electronic in gas and in light oil

PRESSURE LOSS [BURNER HEAD + GAS TRAIN] (mbar)

EKEVO 6.2400 GL-EF3

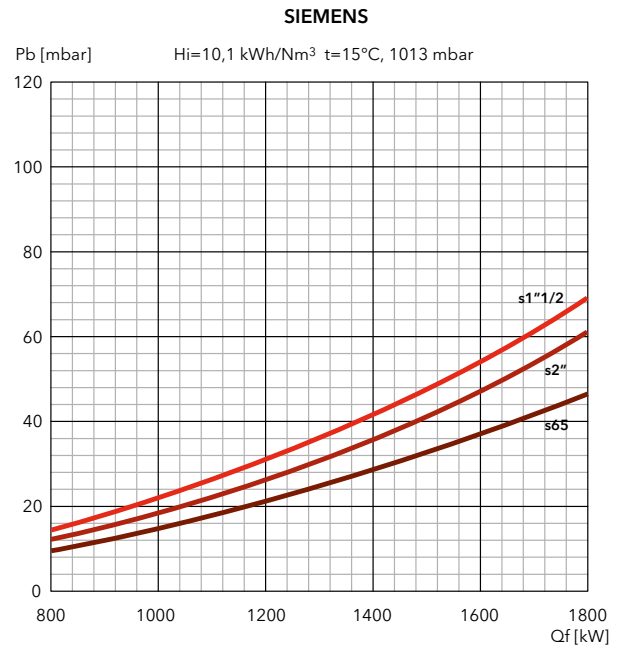
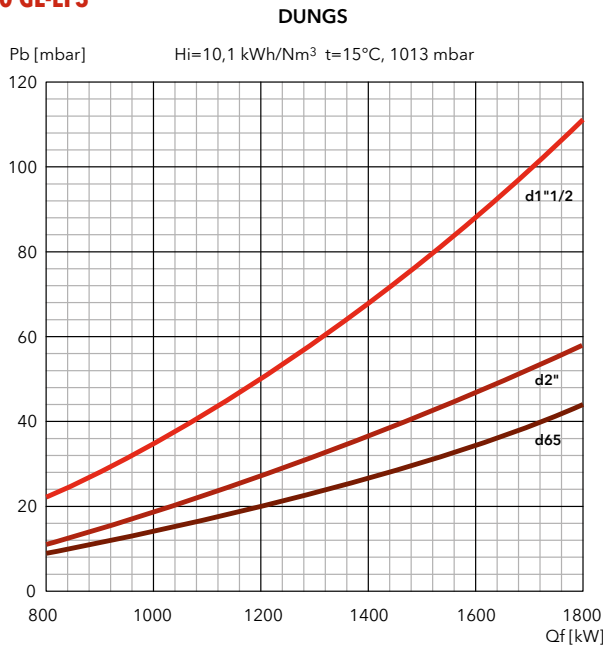

EKEVO 6.2900 GL-EF3

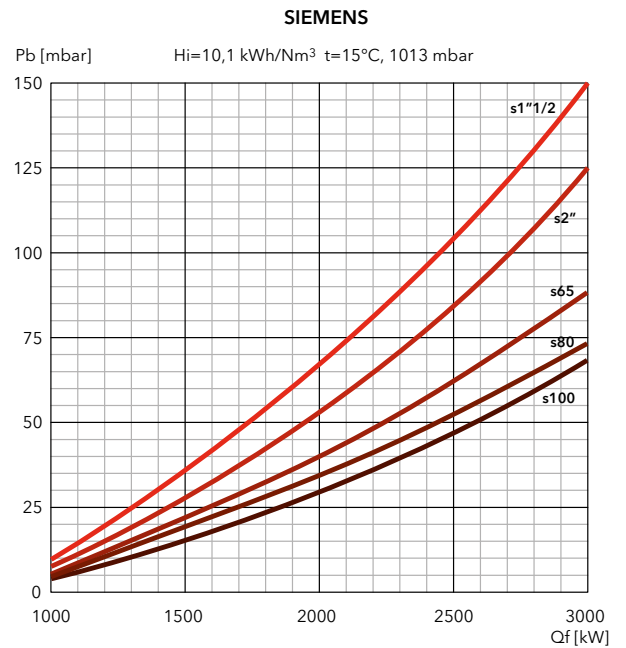
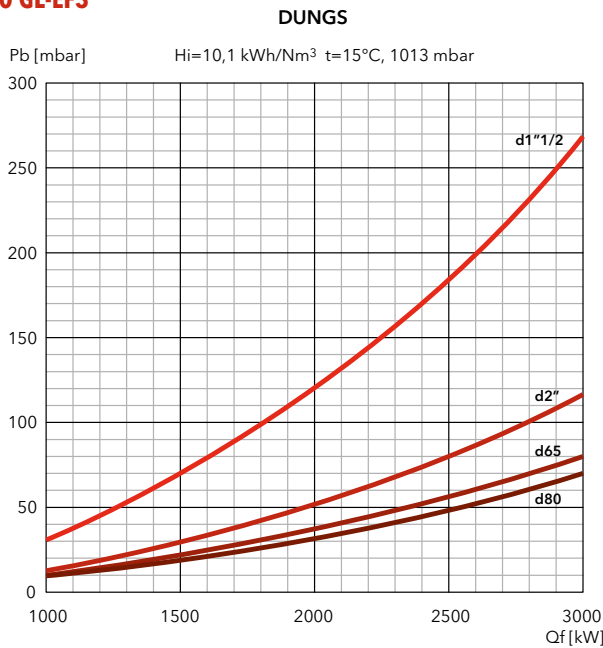

FILTERS

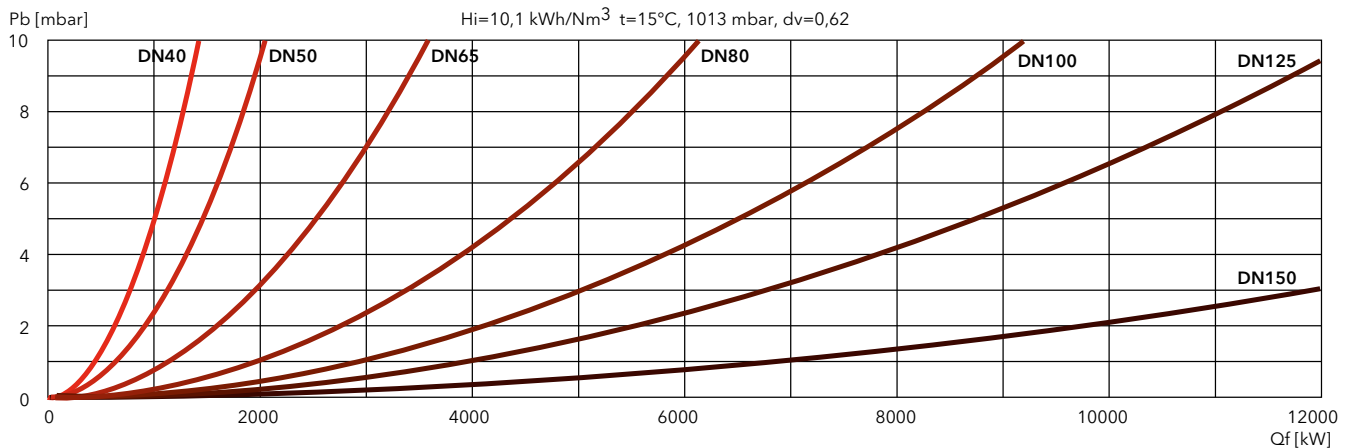



PRESSURE LOSS [BURNER HEAD + GAS TRAIN] (mbar)

EK EVO 7.3600 GL-EF3

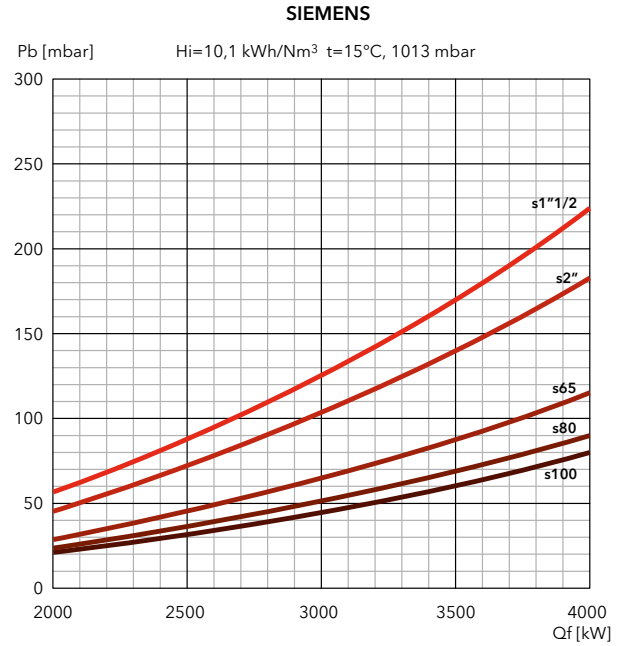
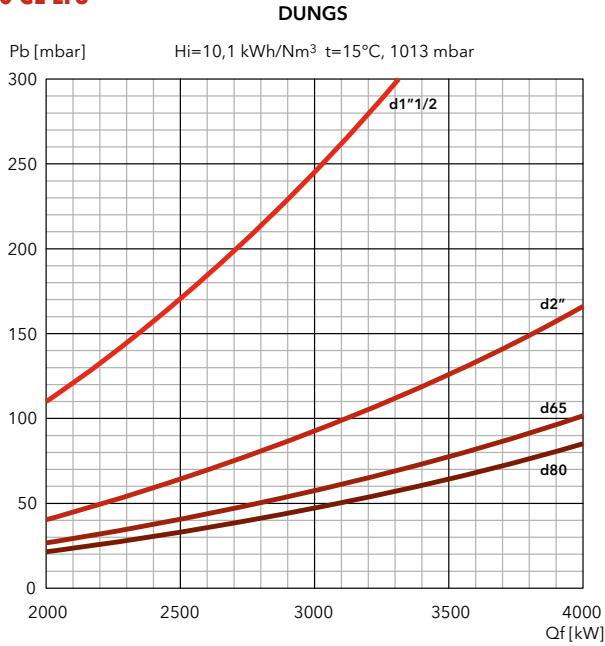

EK EVO 7.4500 GL-EF3

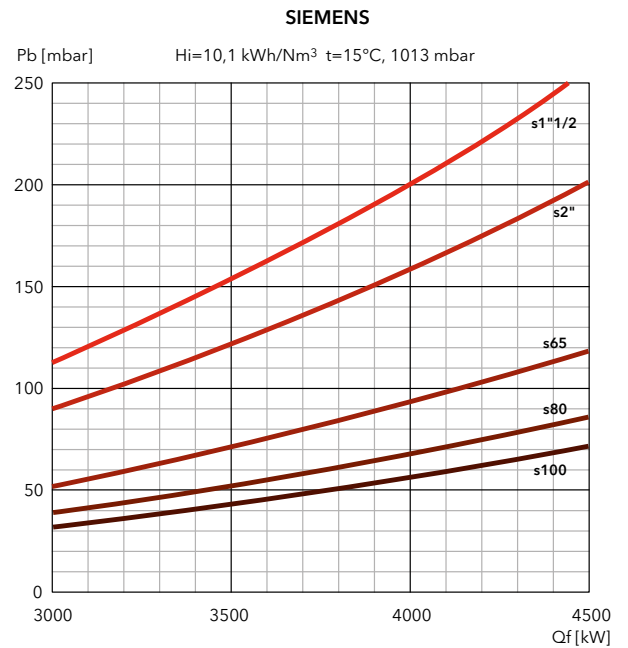
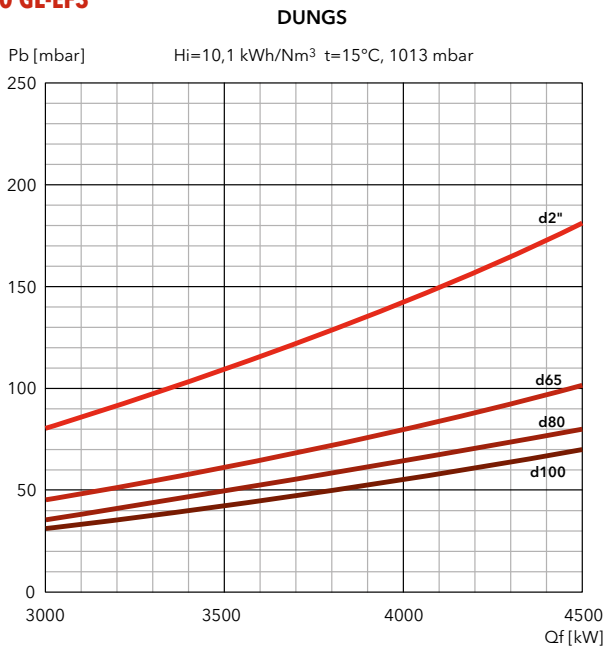

FILTERS

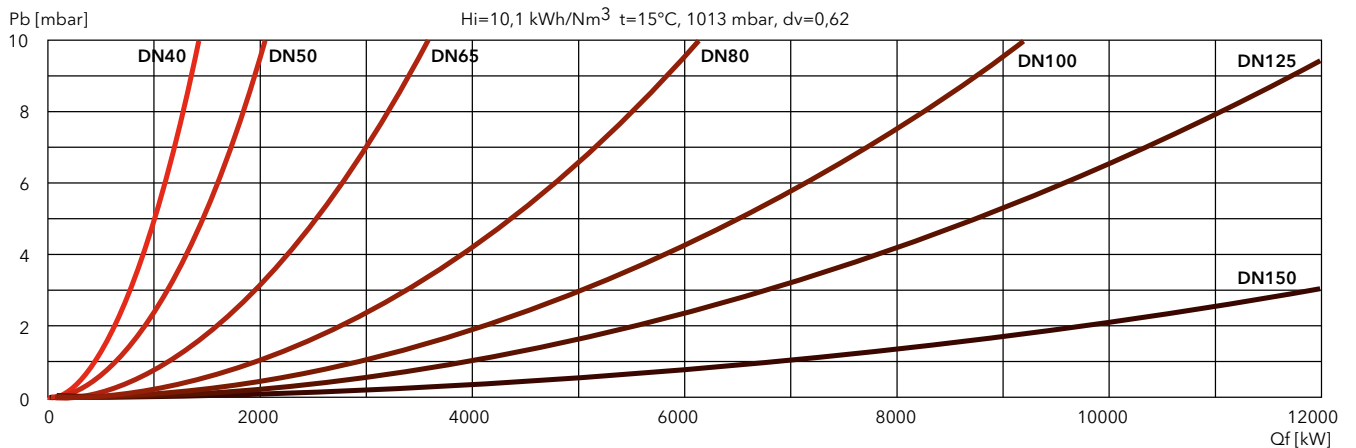

EKEVO 8 GL-EF3 / EKEVO 9 GL-EF3

830 ... 6950 kW

Two stage progressive/modulating electronic in gas and in light oil



- **Fuels:** natural gas, Hi = 6,99 ... 11,39 kWh/Nm³;
light oil, viscosity 6 mm²/s at 20°C, Hi = 11,86 kWh/kg
- **Emission class:** Low NOx class 3 (≤80 mg/kWh) according to EN676 in gas
Low NOx class 3 (≤120 mg/kWh) according to EN267 in light oil
- **Protection level:** IP 41

TECHNICAL DATA

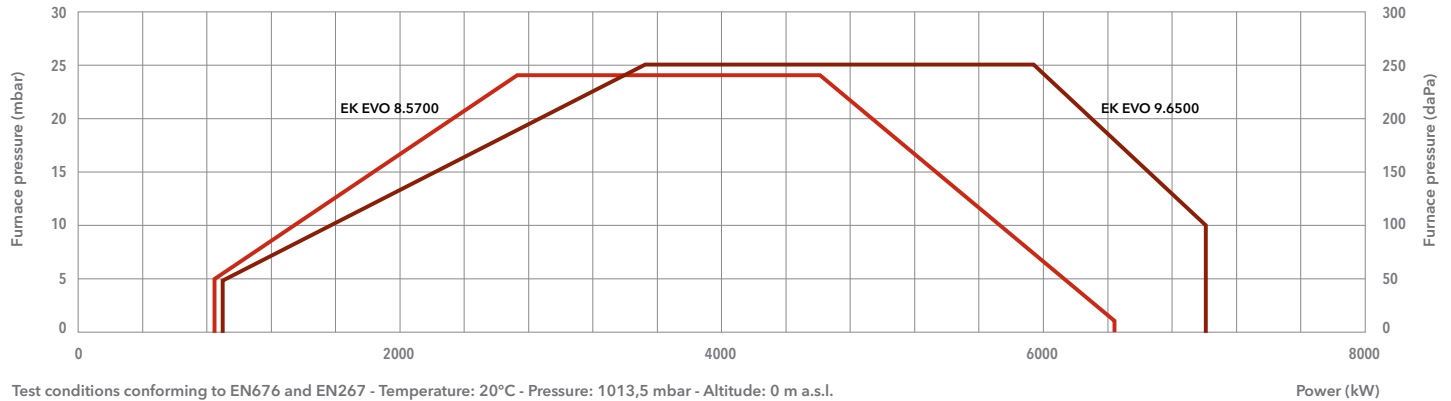

Test conditions conforming to EN676 and EN267 - Temperature: 20°C - Pressure: 1013,5 mbar - Altitude: 0 m a.s.l.

	EKEVO 8.5700 GL-EF3	EKEVO 9.6500 GL-EF3
Operating range gas	830 - 6450 kW	860 - 6950 kW
Operating range oil	1100 - 6450 kW	1100 - 6600 kW
Gas pressure	100 - 500 mbar (100 - 360 mbar for d457)	100 - 500 mbar (100 - 360 mbar for d457)
Gas connection	DN100	DN100
Control box / flame detector	BT300 / FFS08	BT300 / FFS08
Auxiliary voltage	1NPE AC 230 V - 50 Hz TN-S	1NPE AC 230 V - 50 Hz TN-S
Power supply	3PE AC 400 V - 50 Hz	3PE AC 400 V - 50 Hz
Fan motor	50 Hz - 15 kW	50 Hz - 22 kW
Acoustic level	<80,2 dB(A)	<82,9 dB(A)
CE certificate	0085CL0215	0085CL0215
Burner codes (body + head)	KN	3754825
	KM	3754829
	KL	3754833
		3754834

GAS TRAINS

DUNGS

Model	Code
GT-d457-2" (*)	3750515
GT-d458-65	3750516
GT-d459-80	3750517
GT-d460-100	3750518
GT-d125	on request

SIEMENS

Model	Code
GT-s456-1"1/2	3750536
GT-s457-2"	3750537
GT-s458-65	3750538
GT-s459-80	3750539
GT-s460-100	3750540
GT-s461-125	3750541

FILTERS

Model	Code
FG-Rp1"1/2	3757199
FG-Rp2"	3757200
FG-DN65	3757198
FG-DN80	3757201
FG-DN100	3757195
FG-DN125	3757209

*: integrated filter

i Pressure drops graphs: see following pages
Dimensions of gas trains and gas filters: see page 311



DIMENSIONS (mm)

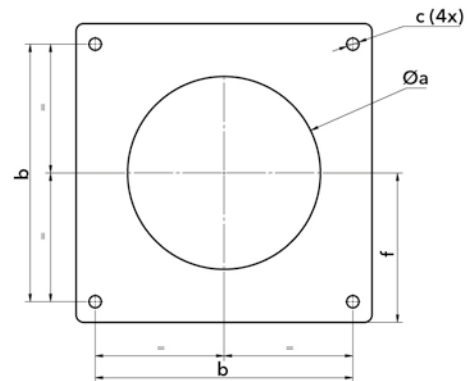
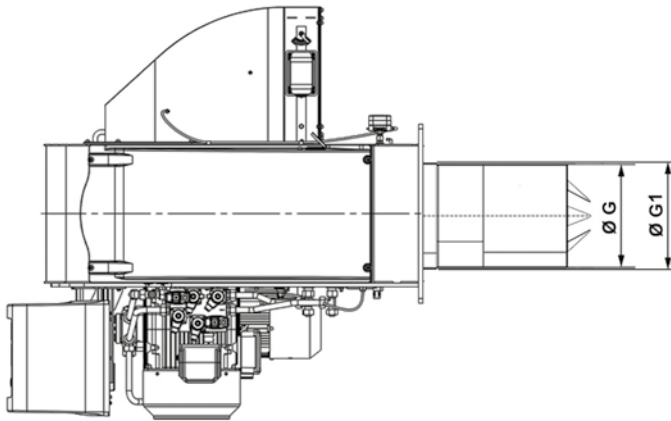
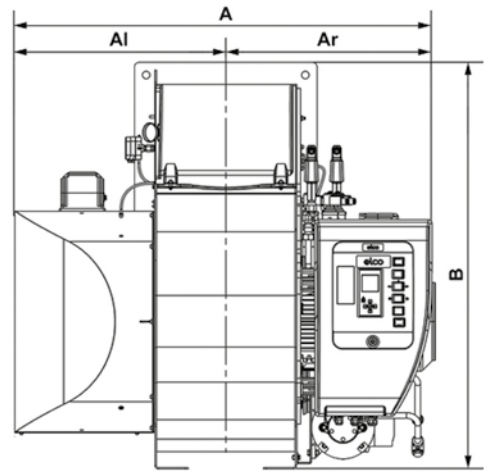
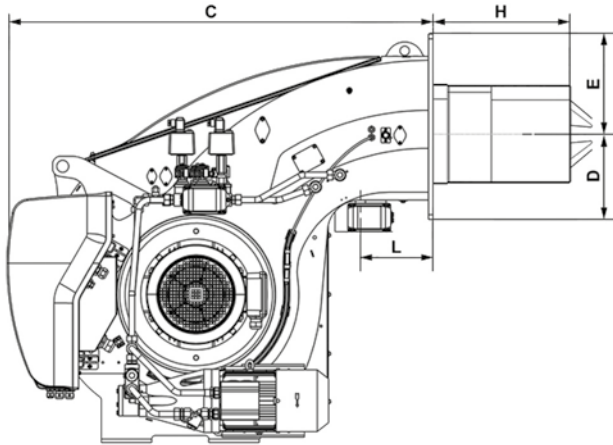

Model	A	Al	Ar	B	C	D	E	ØG	ØG1	H			L	Øa	b	c	f
										KN	KM	KL					
EK EVO 8.5700 GL-EF3	1325	670	655	1231	1351	307	293	369	376	528	668	808	230	385-410	505	M20	293
EK EVO 9.6500 GL-EF3	1400	670	730	1291	1348	332	293	369	438,5	543	693	843	230	450-480	505	M20	293

PACKAGING

The burner is delivered on a pallet with:

- burner body with mounted combustion head
- gas train and filter
- boiler fixing accessories
- technical documentation

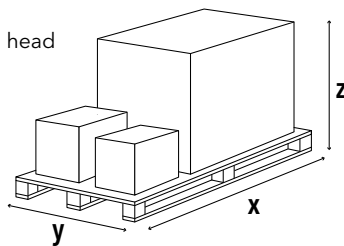

Model	Dimensions (mm)			Gross weight (kg)
	X	Y	Z	
EK EVO 8.5700 GL-EF3	2300	1500	1573	580
EK EVO 9.6500 GL-EF3	2300	1500	1573	700

EKEVO 8 GL-EF3 / EKEVO 9 GL-EF3

830 ... 6950 kW

Two stage progressive/modulating electronic in gas and in light oil

PRESSURE LOSS [BURNER HEAD + GAS TRAIN] (mbar)

EKEVO 8.5700 GL-EF3

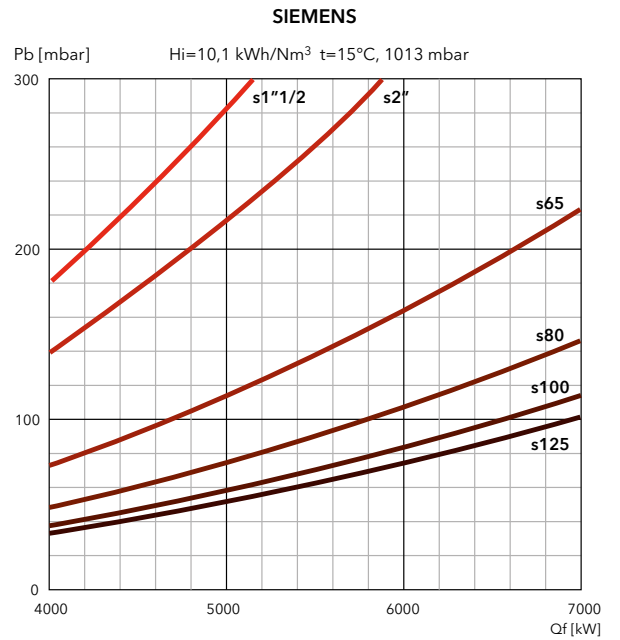
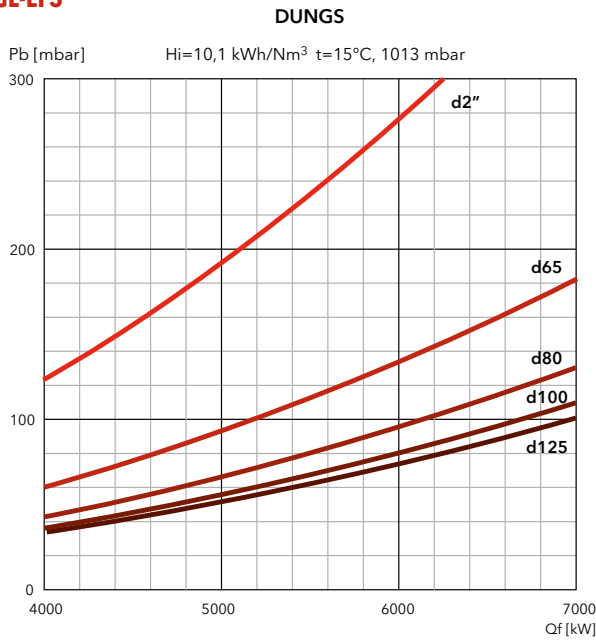

FILTERS

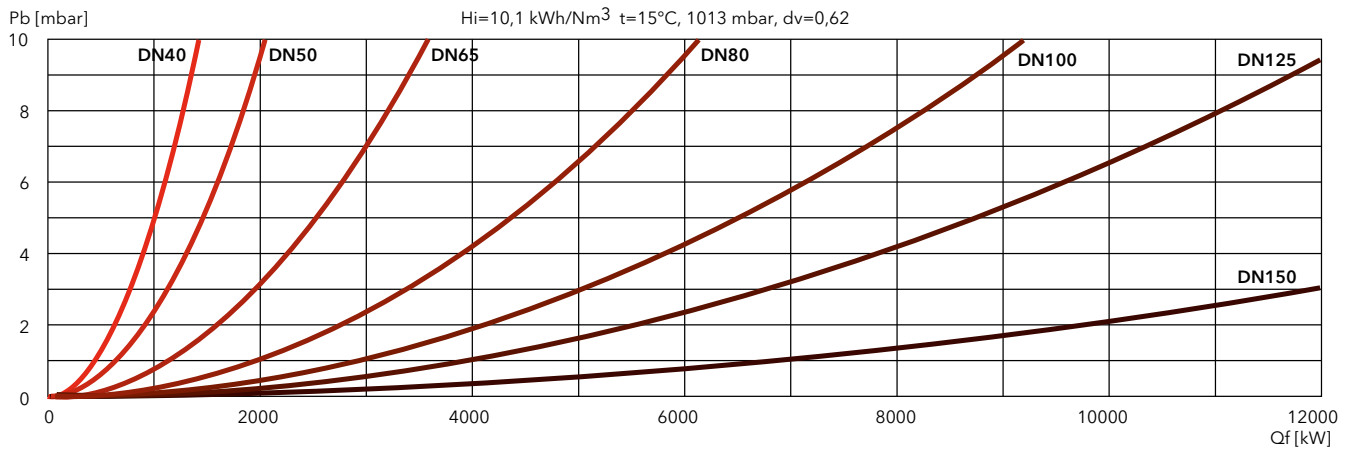



PRESSURE LOSS [BURNER HEAD + GAS TRAIN] (mbar)

EK EVO 9.6500 GL-EF3

DUNGS

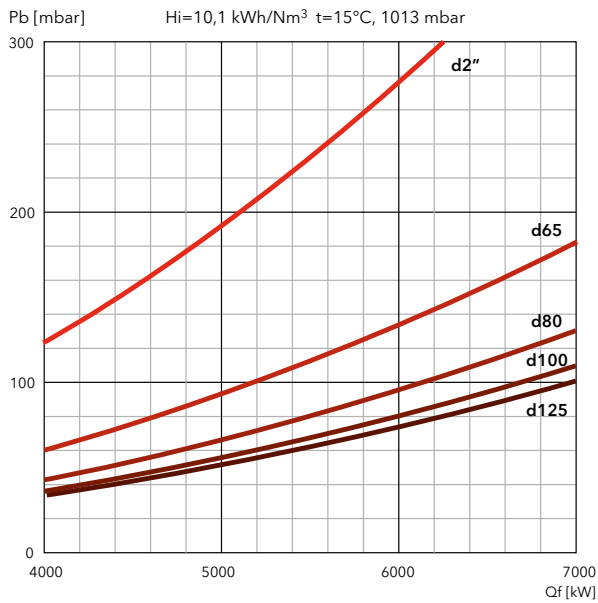

SIEMENS

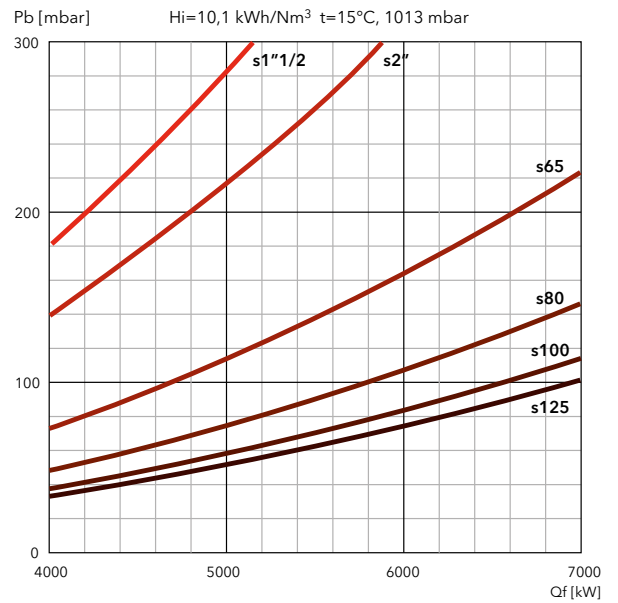

FILTERS

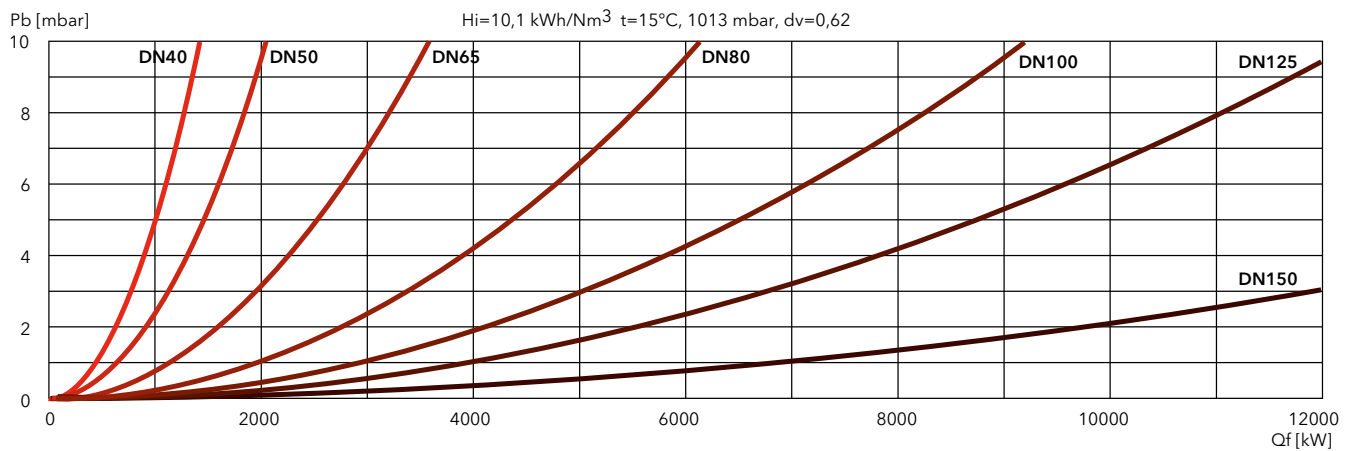

EKEVO 9 GL-EUF

1040 ... 9570 kW

Two stage progressive/modulating electronic in gas and in light oil



- **Fuels:** natural gas, Hi = 6,99 ... 11,39 kWh/Nm³;
light oil, viscosity 6 mm²/s at 20°C, Hi = 11,86 kWh/kg
- **Emission class:** Low NOx class 3 (≤80 mg/kWh) according to EN676 in gas
Low NOx class 3 (≤120 mg/kWh) according to EN267 in light oil
- **Protection level:** IP 41

TECHNICAL DATA

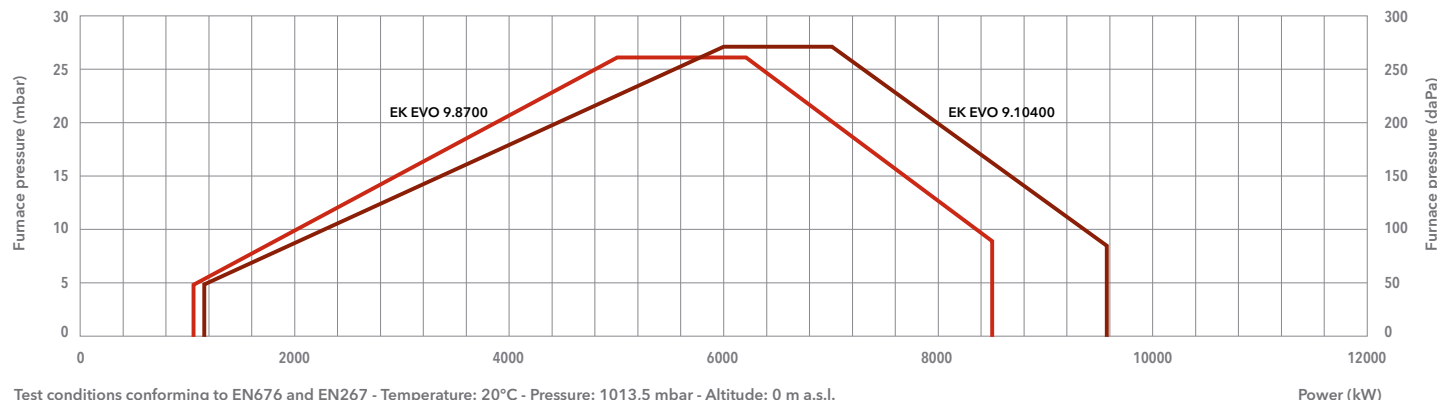

Test conditions conforming to EN676 and EN267 - Temperature: 20°C - Pressure: 1013,5 mbar - Altitude: 0 m a.s.l.

	EK EVO 9.8700 GL-EUF	EK EVO 9.10400 GL-EUF
Operating range gas	1040 - 8500 kW	1160 - 9570 kW
Operating range oil	1800 - 8500 kW	2550 - 9570 kW
Gas pressure	100 - 500 mbar (100 - 360 mbar for d457)	100 - 500 mbar (100 - 360 mbar for d457)
Gas connection	DN100	DN100
Control box / flame detector	BT300 / FFS08	BT300 / FFS08
Auxiliary voltage	1NPE AC 230 V - 50 Hz TN-S	1NPE AC 230 V - 50 Hz TN-S
Power supply	3PE AC 400 V - 50 Hz	3PE AC 400 V - 50 Hz
Fan motor	50 Hz - 18,5 kW	50 Hz - 22 kW
Acoustic level	<85,9 dB(A)	<86,6 dB(A)
CE certificate	0085CL0215	0085CL0215
Burner codes (body + head)	KN	3754827
	KM	3754831
	KL	3754835

GAS TRAINS

DUNGS

Model	Code
GT-d457-2" (*)	3750515
GT-d458-65	3750516
GT-d459-80	3750517
GT-d460-100	3750518

SIEMENS

Model	Code
GT-s457-2"	3750537
GT-s458-65	3750538
GT-s459-80	3750539
GT-s460-100	3750540
GT-s461-125	3750541

FILTERS

Model	Code
FG-Rp2"	3757200
FG-DN65	3757198
FG-DN80	3757201
FG-DN100	3757195
FG-DN125	3757209

*: integrated filter

i Pressure drops graphs: see following pages
Dimensions of gas trains and gas filters: see page 311



DIMENSIONS (mm)

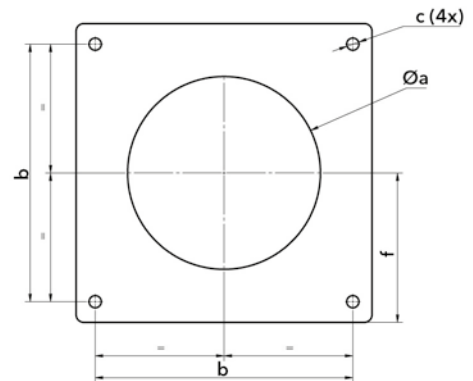
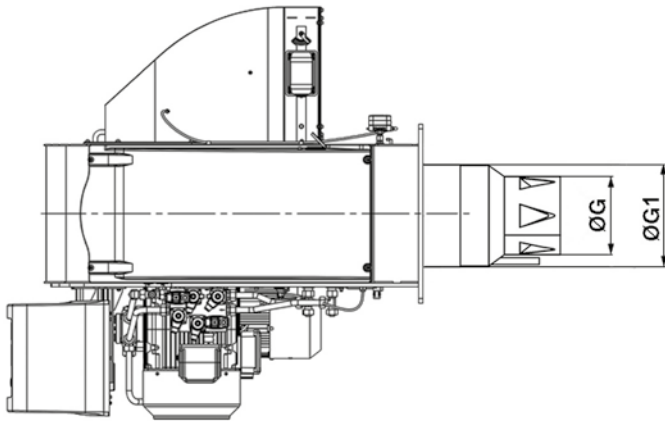
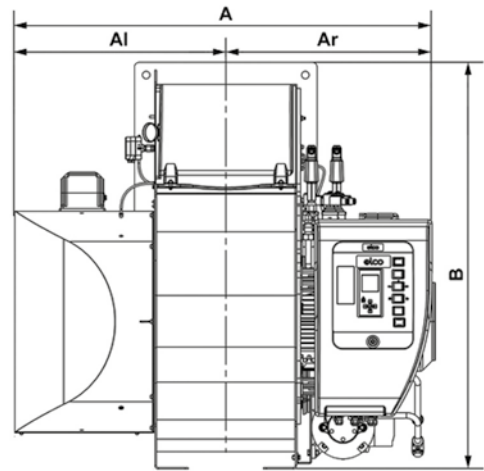
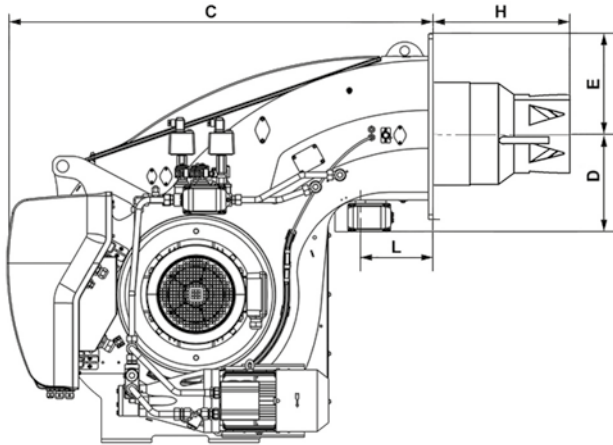

Model	A	Al	Ar	B	C	D	E	ØG	ØG1	H			L	Øa	b	c	f
										KN	KM	KL					
EK EVO 9.8700 GL-EUF	1336	670	666	1291	1348	332	293	325	438,5	575	725	875	230	450-480	505	M20	293
EK EVO 9.10400 GL-EUF	1393	670	723	1291	1348	332	293	335	438,5	575	725	875	230	450-480	505	M20	293

PACKAGING

The burner is delivered on a pallet with:

- burner body with mounted combustion head
- gas train and filter
- boiler fixing accessories
- technical documentation

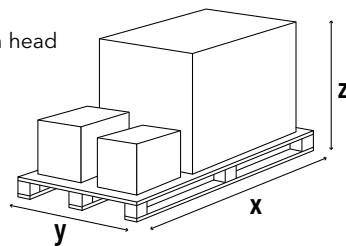

Model	Dimensions (mm)			Gross weight (kg)
	X	Y	Z	
EK EVO 9.8700 GL-EUF	2300	1500	1573	700
EK EVO 9.10400 GL-EUF	2300	1500	1573	700

EKEVO 9 GL-EUF

1040 ... 9570 kW

Two stage progressive/modulating electronic in gas and in light oil

PRESSURE LOSS [BURNER HEAD + GAS TRAIN] (mbar)

EK EVO 9.8700 GL-EUF

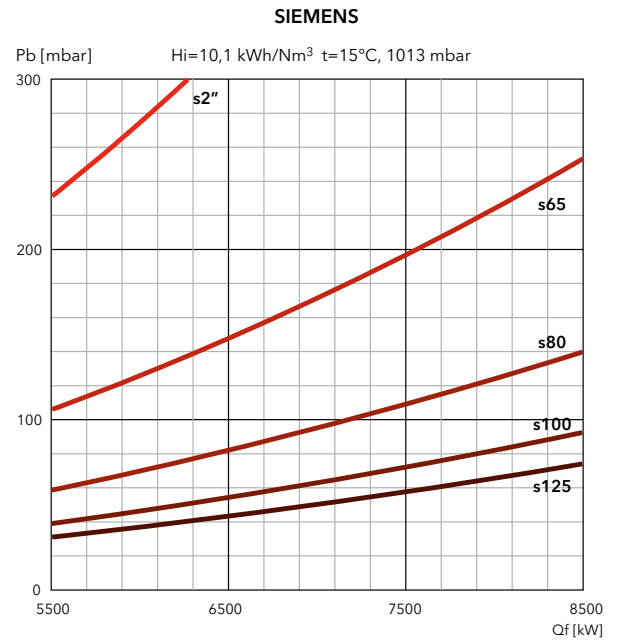
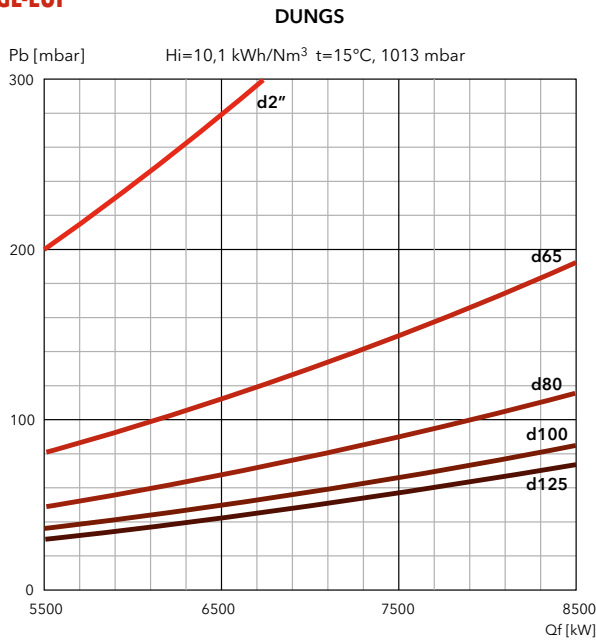

FILTERS

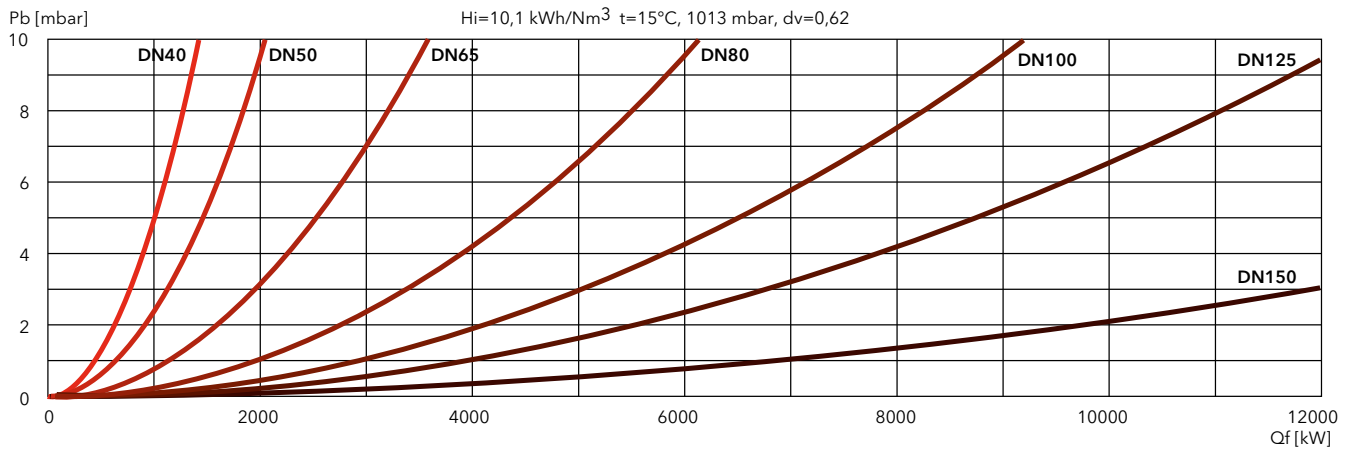



PRESSURE LOSS [BURNER HEAD + GAS TRAIN] (mbar)

EK EVO 9.10400 GL-EUF

DUNGS

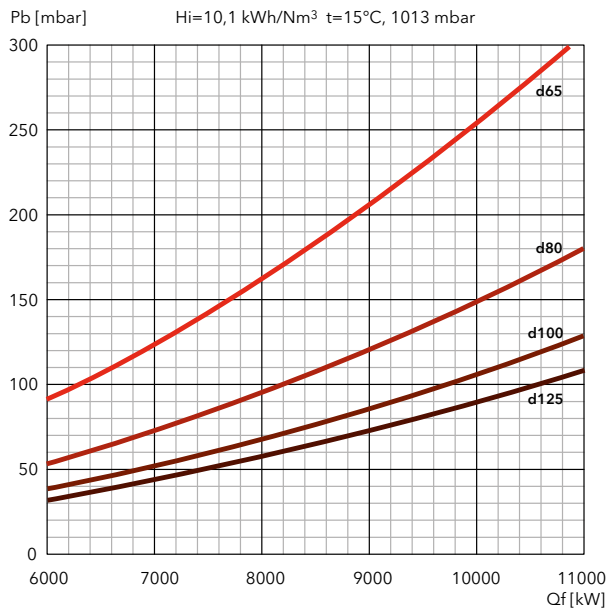

SIEMENS

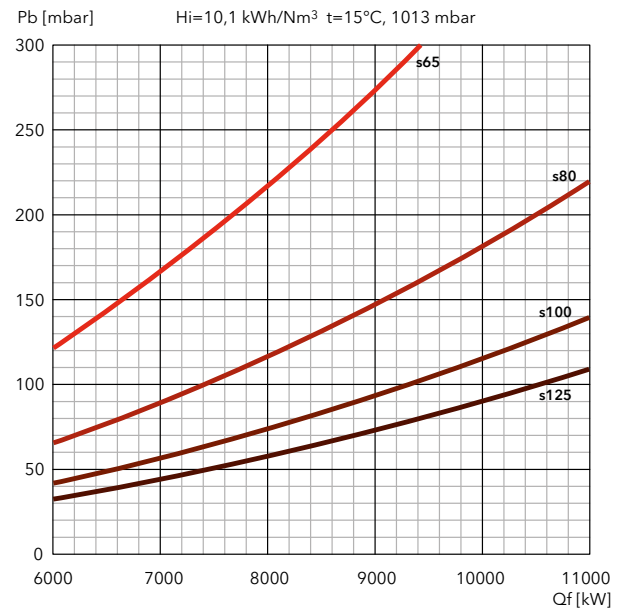

FILTERS

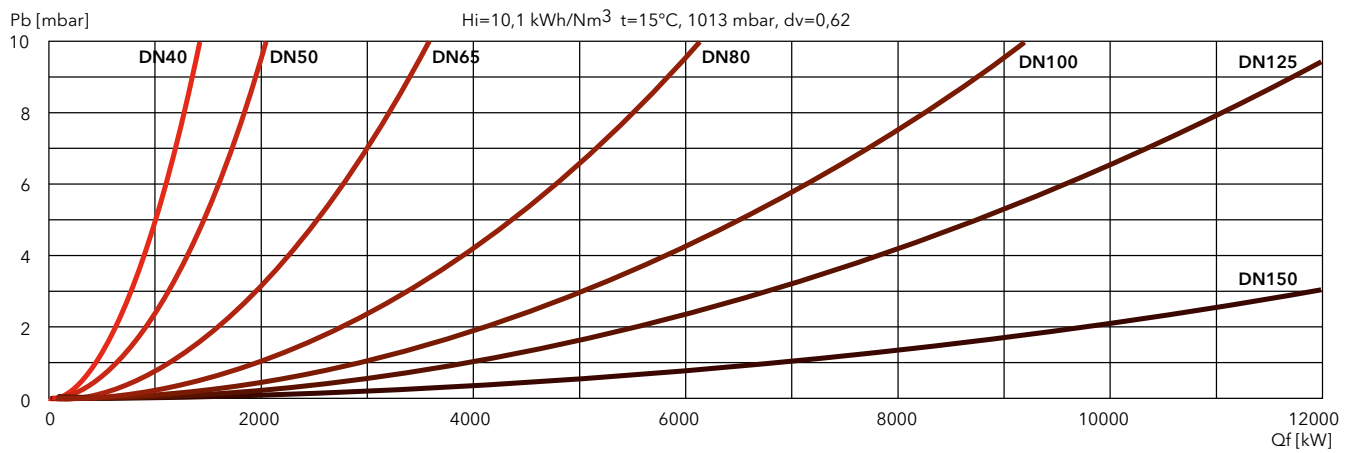

EKEVO 6 GL-EZ3 / EKEVO 7 GL-EZ3

290 ... 4740 kW

Two stage progressive/modulating electronic in gas / Three stages in light oil

- **Fuels:** natural gas, Hi = 6,99 ... 11,39 kWh/Nm³;
light oil, viscosity 6 mm²/s at 20°C, Hi = 11,86 kWh/kg
- **Emission class:** Low NOx class 2 (≤120 mg/kWh) according to EN676 in gas
Low NOx class 2 (≤185 mg/kWh) according to EN267 in light oil
- **Protection level:** IP 41



TECHNICAL DATA

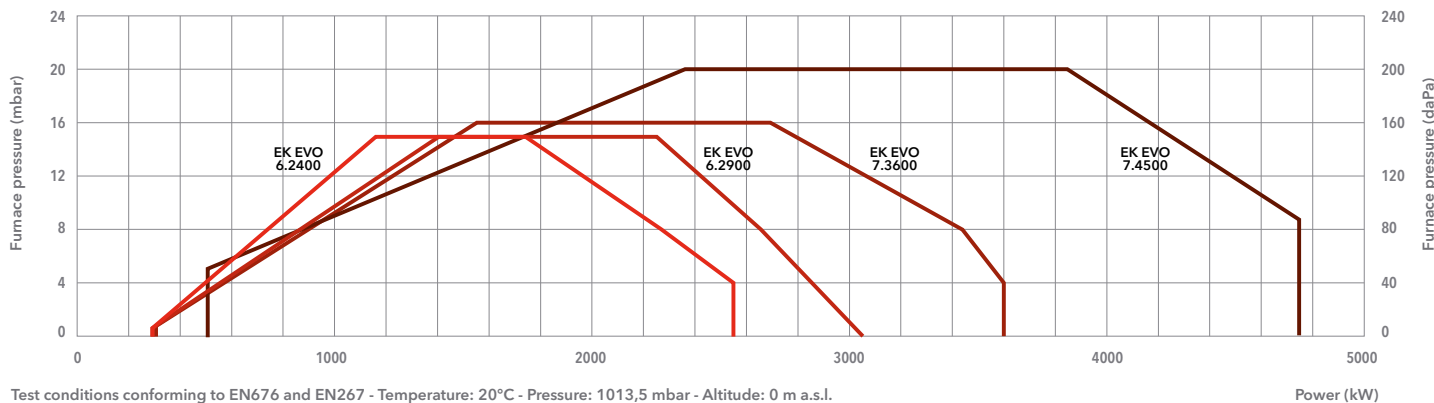

Test conditions conforming to EN676 and EN267 - Temperature: 20°C - Pressure: 1013,5 mbar - Altitude: 0 m a.s.l.

	EK EVO 6.2400 GL-EZ3	EK EVO 6.2900 GL-EZ3	EK EVO 7.3600 GL-EZ3	EK EVO 7.4500 GL-EZ3
Operating range gas	290 - 2550 kW	290 - 3050 kW	300 - 3600 kW	510 - 4740 kW
Operating range oil	730 - 2470 kW	730 - 2790 kW	1090 - 3600 kW	1300 - 4740 kW
Gas pressure	50 - 500 mbar (50 - 360 mbar for d452 and d453)		50 - 500 mbar (50 - 360 mbar for d452 and d453)	
Gas connection	DN65	DN65	DN65	DN65
Control box / flame detector	BT300 / QRA2	BT300 / QRA2	BT300 / QRA2	BT300 / QRA2
Auxiliary voltage	1NPE AC 230 V - 50 Hz TN-S	1NPE AC 230 V - 50 Hz TN-S	1NPE AC 230 V - 50 Hz TN-S	1NPE AC 230 V - 50 Hz TN-S
Power supply	3PE AC 400 V - 50 Hz	3PE AC 400 V - 50 Hz	3PE AC 400 V - 50 Hz	3PE AC 400 V - 50 Hz
Fan motor	50 Hz - 3 kW	50 Hz - 4 kW	50 Hz - 5,5 kW	50 Hz - 7,5 kW
Acoustic level	<75 dB(A)	<77 dB(A)	<81 dB(A)	<82,5 dB(A)
CE certificate	0085CL0215	0085CL0215	0085CL0215	0085CL0215
Burner codes (body + head)	KN	3760186	3760189	3760195
	KM	3760187	3760190	3760196
	KL	3760188	3760191	3760197

GAS TRAINS

DUNGS

Model	Code
GT-d452-1"1/2 (*)	3750510
GT-d453-2" (*)	3750511
GT-d454-65	3750512
GT-d455-80	3750513
GT-d456-100	3750514

SIEMENS

Model	Code
GT-s451-1"1/2	3750525
GT-s452-2"	3750526
GT-s453-65	3750527
GT-s454-80	3750528
GT-s455-100	3750529
GT-s456-125	3750530

FILTERS

Model	Code
FG-Rp1"1/2	3757199
FG-Rp2"	3757200
FG-DN65	3757198
FG-DN80	3757201
FG-DN100	3757195
FG-DN125	3757209

*: integrated filter

i **Pressure drops graphs:** see following pages
Dimensions of gas trains and gas filters: see page 310



DIMENSIONS (mm)

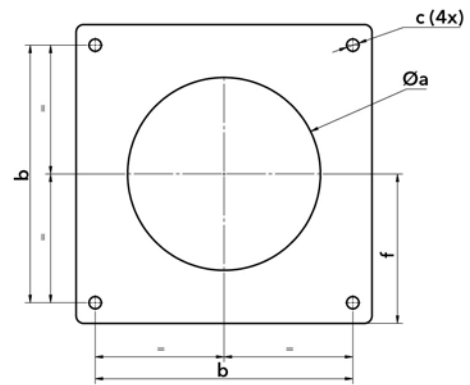
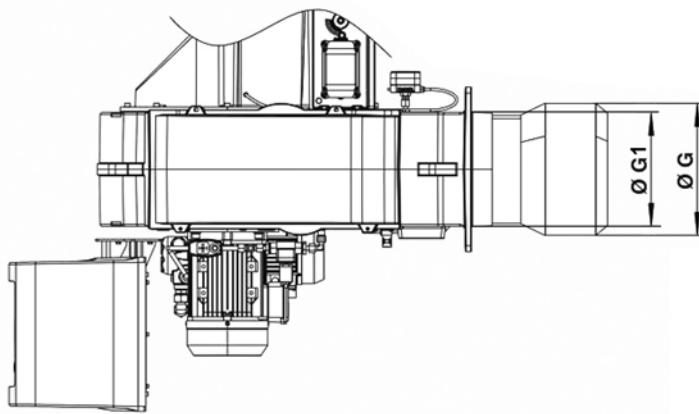
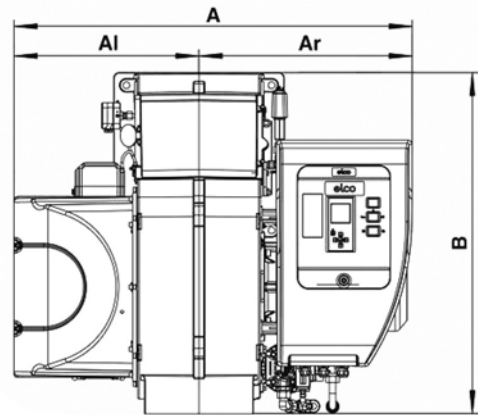
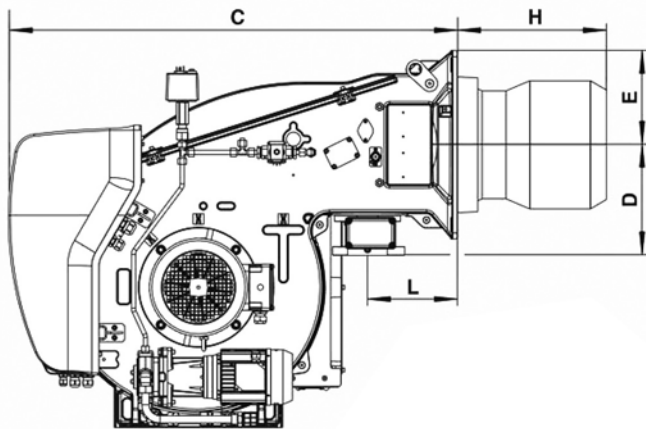

Model	A	AI	Ar	B	C	D	E	ØG	ØG1	H			L	Øa	b	c	f
										KN	KM	KL					
EK EVO 6.2400 GL-EZ3	1035	479	556	812	1050	245	200	320	277	330	450	570	215	330-340	340	M16	200
EK EVO 6.2900 GL-EZ3	1035	479	556	812	1050	245	200	320	277	330	450	570	215	330-340	340	M16	200
EK EVO 7.3600 GL-EZ3	1107	510	597	941	1130	276	235	320	339	370	500	630	225	330-400	400	M16	235
EK EVO 7.4500 GL-EZ3	1107	510	597	941	1130	276	235	370	339	370	500	630	225	380-400	400	M16	235

PACKAGING

The burner is delivered on a pallet with:

- burner body with mounted combustion head
- gas train and filter
- boiler fixing accessories
- technical documentation

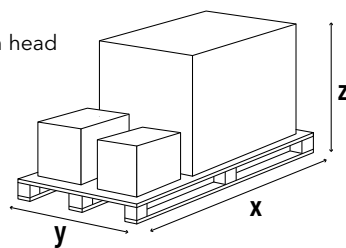

Model	Dimensions (mm)			Gross weight (kg)
	X	Y	Z	
EK EVO 6.2400 GL-EZ3	2046	1414	1233	300
EK EVO 6.2900 GL-EZ3	2046	1414	1233	300
EK EVO 7.3600 GL-EZ3	2046	1414	1233	350
EK EVO 7.4500 GL-EZ3	2046	1414	1233	350

EKEVO 6 GL-EZ3 / EKEVO 7 GL-EZ3

290 ... 4740 kW

Two stage progressive/modulating electronic in gas / Three stages in light oil

PRESSURE LOSS [BURNER HEAD + GAS TRAIN] (mbar)

EKEVO 6.2400 GL-EZ3

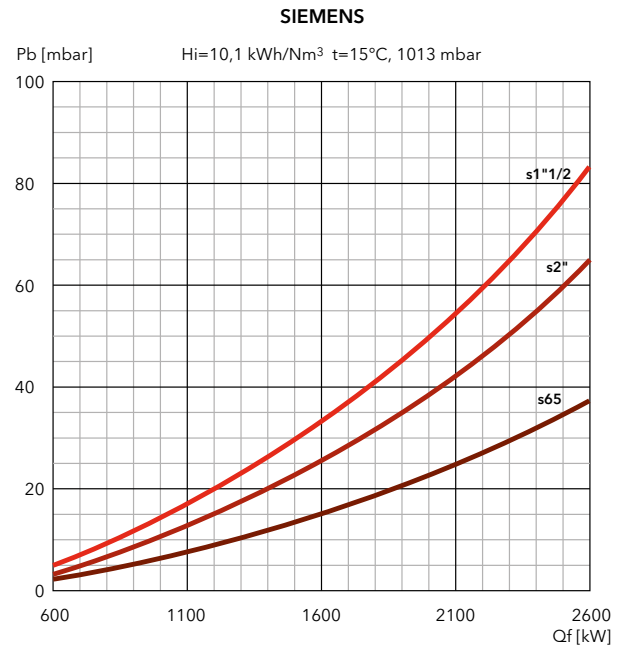
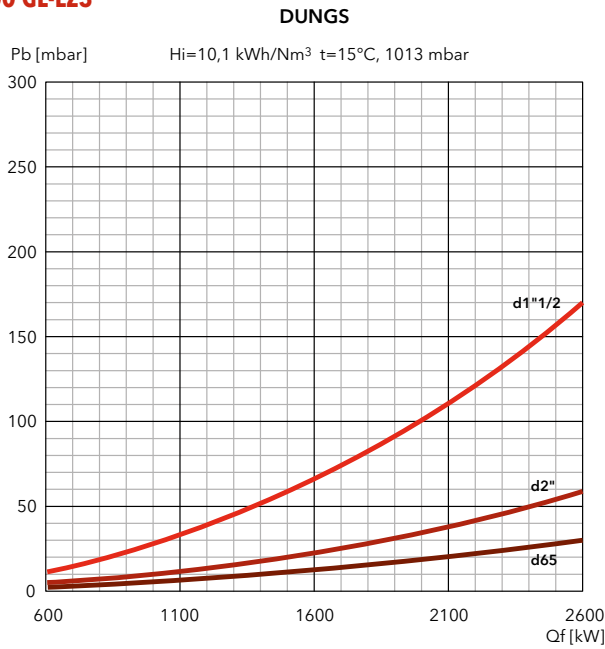

EKEVO 6.2900 GL-EZ3

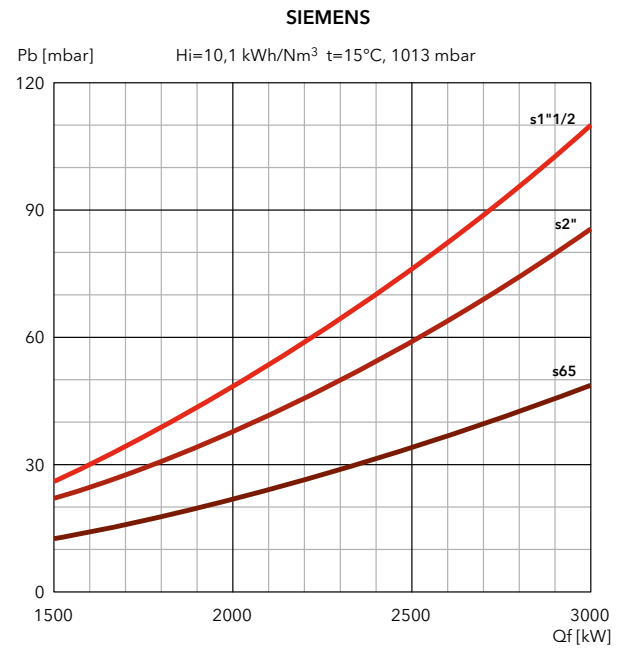
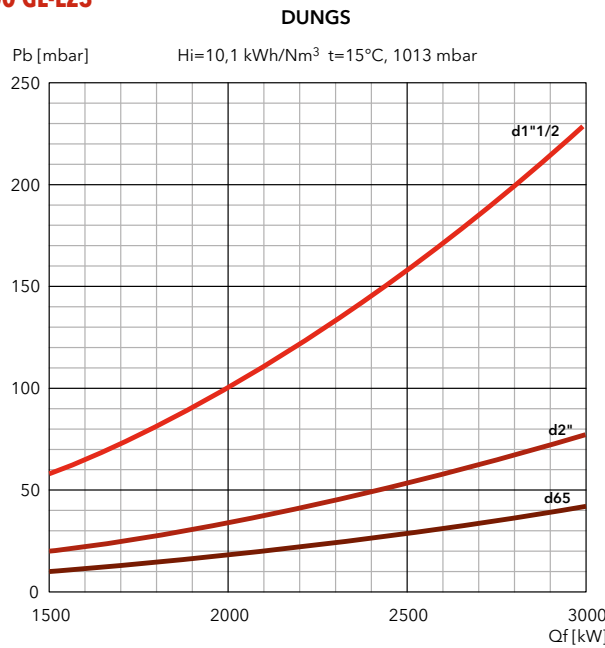

FILTERS

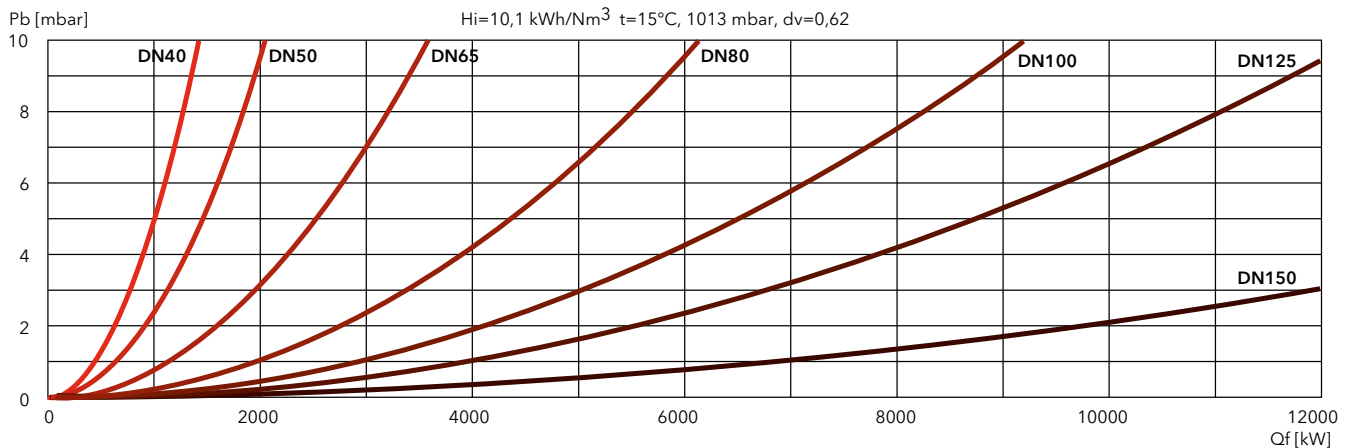



PRESSURE LOSS [BURNER HEAD + GAS TRAIN] (mbar)

EK EVO 7.3600 GL-EZ3

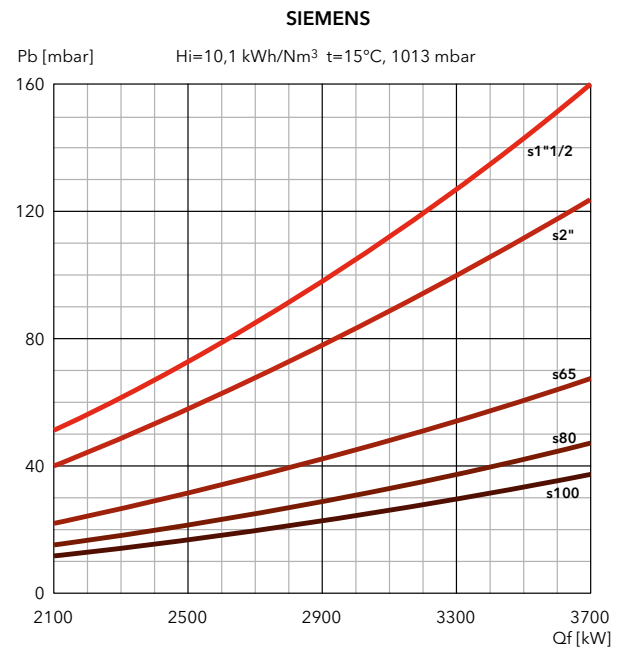
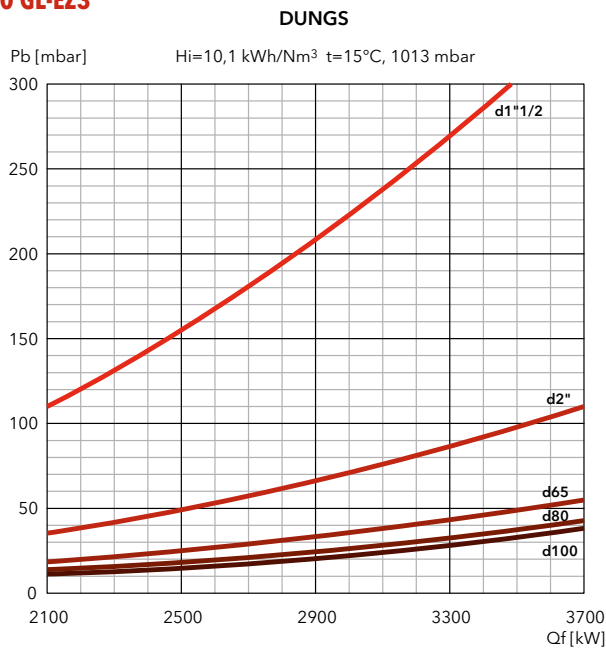

EK EVO 7.4500 GL-EZ3

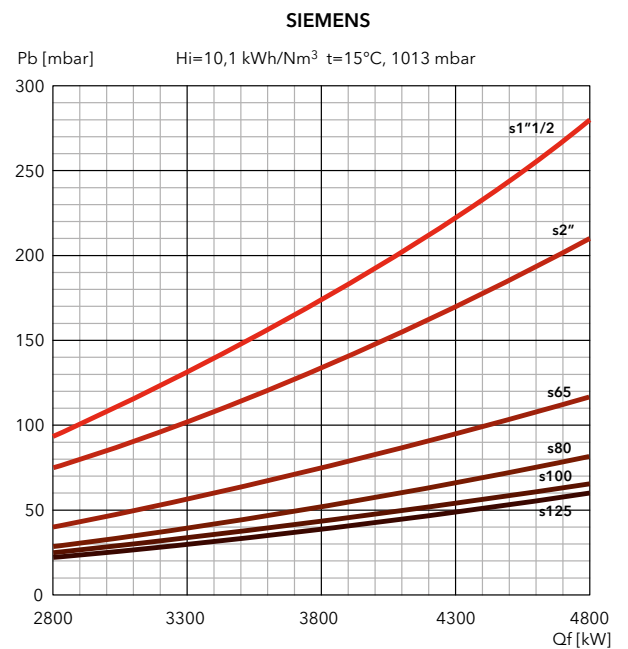
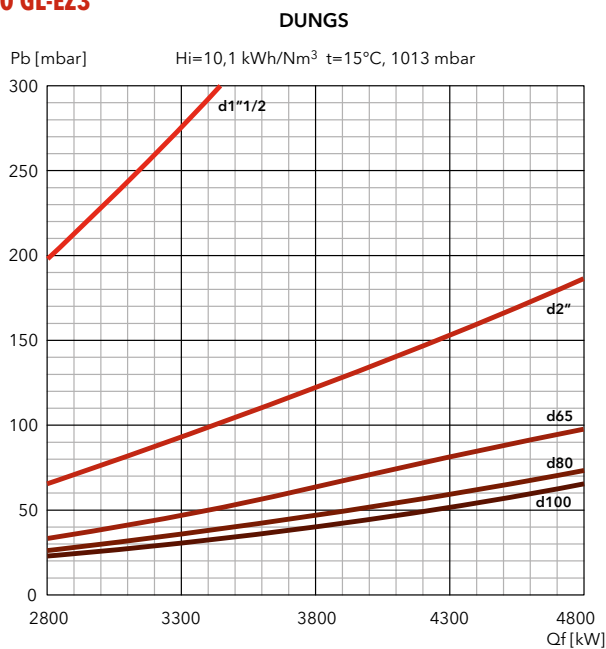

FILTERS

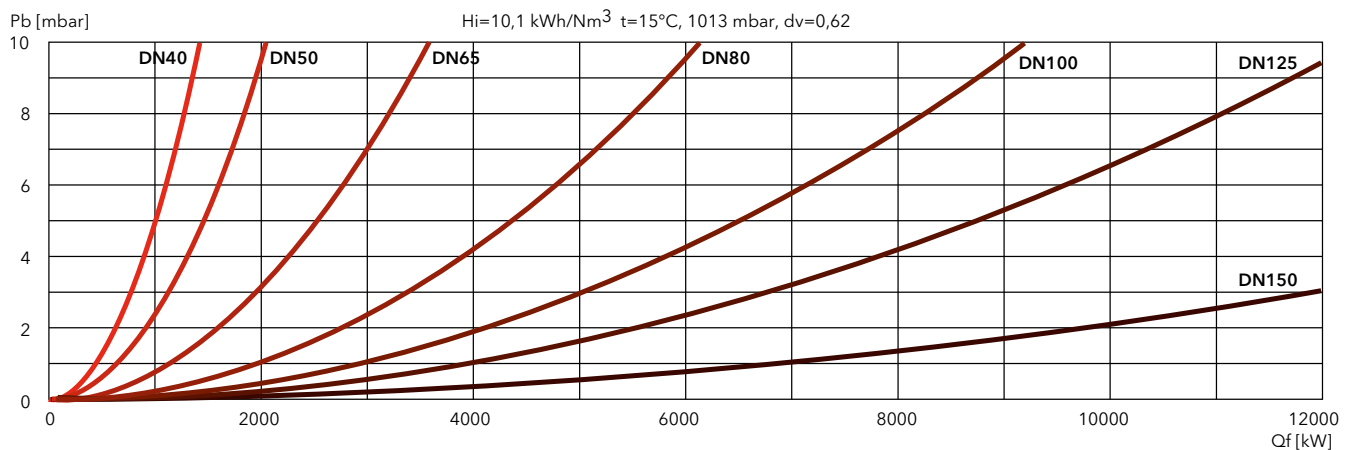

EKEVO 6 GL-E / EKEVO 7 GL-E

250 ... 4740 kW

Two stage progressive/modulating electronic in gas and in light oil



- **Fuels:** natural gas, Hi = 6,99 ... 11,39 kWh/Nm³;
light oil, viscosity 6 mm²/s at 20°C, Hi = 11,86 kWh/kg
- **Emission class:** Low NOx class 2 (≤120 mg/kWh) according to EN676 in gas
Low NOx class 2 (≤185 mg/kWh) according to EN267 in light oil
- **Protection level:** IP 41

TECHNICAL DATA

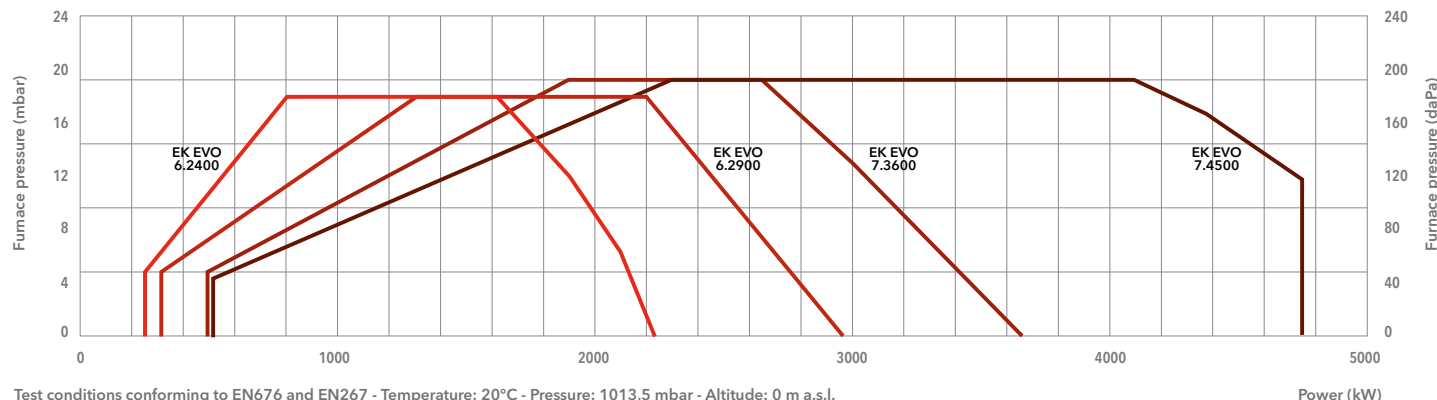

Test conditions conforming to EN676 and EN267 - Temperature: 20°C - Pressure: 1013,5 mbar - Altitude: 0 m a.s.l.

	EK EVO 6.2400 GL-E	EK EVO 6.2900 GL-E	EK EVO 7.3600 GL-E	EK EVO 7.4500 GL-E
Operating range gas	250 - 2230 kW	320 - 2970 kW	490 - 3650 kW	510 - 4740 kW
Operating range oil	510 - 2030 kW	650 - 2970 kW	900 - 3650 kW	1300 - 4740 kW
Gas pressure	50 - 500 mbar (50 - 360 mbar for d452 and d453)		50 - 500 mbar (50 - 360 mbar for d452 and d453)	
Gas connection	DN65	DN65	DN65	DN65
Control box / flame detector	BT300 / QRA2	BT300 / QRA2	BT300 / QRA2	BT300 / QRA2
Auxiliary voltage	1NPE AC 230 V - 50 Hz TN-S	1NPE AC 230 V - 50 Hz TN-S	1NPE AC 230 V - 50 Hz TN-S	1NPE AC 230 V - 50 Hz TN-S
Power supply	3PE AC 400 V - 50 Hz	3PE AC 400 V - 50 Hz	3PE AC 400 V - 50 Hz	3PE AC 400 V - 50 Hz
Fan motor	50 Hz - 3 kW	50 Hz - 4 kW	50 Hz - 5,5 kW	50 Hz - 7,5 kW
Acoustic level	<77 dB(A)	<77 dB(A)	<81 dB(A)	<82,5 dB(A)
CE certificate	0085CL0215	0085CL0215	0085CL0215	0085CL0215
Burner codes (body + head)	KN	3754276	3754277	3754279
	KM	3754280	3754281	3754283
	KL	3754284	3754285	3754287

GAS TRAINS

DUNGS

Model	Code
GT-d452-1"1/2 (*)	3750510
GT-d453-2" (*)	3750511
GT-d454-65	3750512
GT-d455-80	3750513
GT-d456-100	3750514

SIEMENS

Model	Code
GT-s451-1"1/2	3750525
GT-s452-2"	3750526
GT-s453-65	3750527
GT-s454-80	3750528
GT-s455-100	3750529
GT-s456-125	3750530

FILTERS

Model	Code
FG-Rp1"1/2	3757199
FG-Rp2"	3757200
FG-DN65	3757198
FG-DN80	3757201
FG-DN100	3757195
FG-DN125	3757209

*: integrated filter

Pressure drops graphs: see following pages
Dimensions of gas trains and gas filters: see page 310



DIMENSIONS (mm)

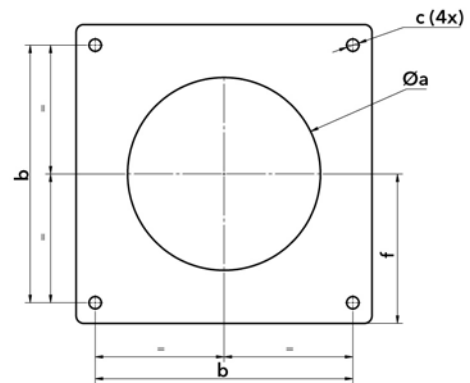
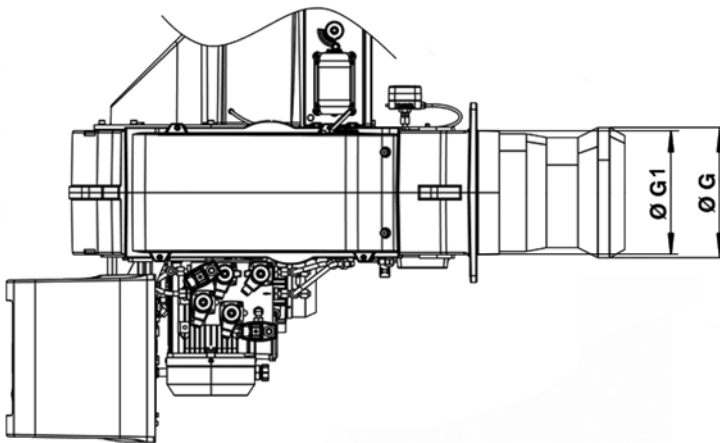
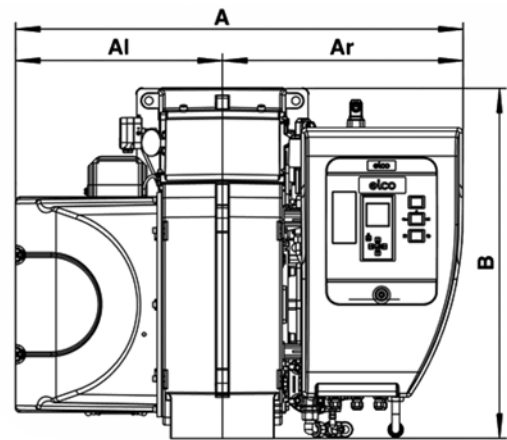
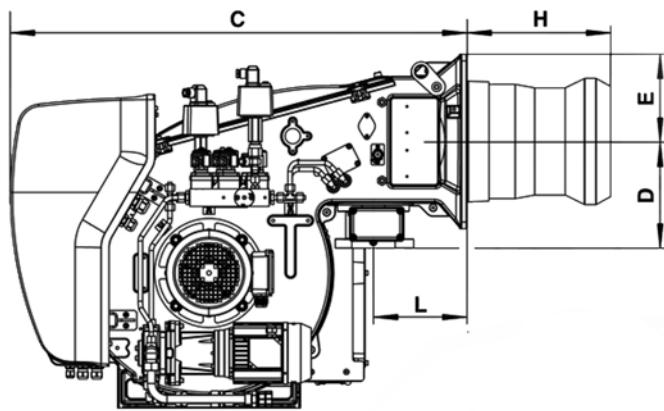

Model	A	AI	Ar	B	C	D	E	ØG	ØG1	H			L	Øa	b	c	f
										KN	KM	KL					
EK EVO 6.2400 GL-E	1035	479	556	812	1050	245	200	290	277	300	450	570	215	300-340	340	M16	200
EK EVO 6.2900 GL-E	1035	479	556	812	1050	245	200	310	277	300	450	570	215	320-340	340	M16	200
EK EVO 7.3600 GL-E	1107	510	597	941	1130	276	235	340	339	370	500	630	225	350-400	400	M16	235
EK EVO 7.4500 GL-E	1107	510	597	941	1130	276	235	370	339	370	500	630	225	380-400	400	M16	235

PACKAGING

The burner is delivered on a pallet with:

- burner body with mounted combustion head
- gas train and filter
- boiler fixing accessories
- technical documentation

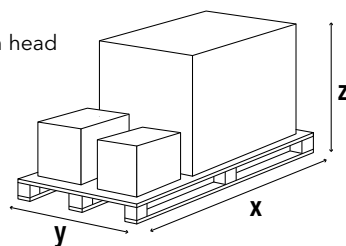

Model	Dimensions (mm)			Gross weight (kg)
	X	Y	Z	
EK EVO 6.2400 GL-E	2046	1414	1233	300
EK EVO 6.2900 GL-E	2046	1414	1233	300
EK EVO 7.3600 GL-E	2046	1414	1233	350
EK EVO 7.4500 GL-E	2046	1414	1233	350

EKEVO 6 GL-E / EKEVO 7 GL-E

250 ... 4740 kW

Two stage progressive/modulating electronic in gas and in light oil

PRESSURE LOSS [BURNER HEAD + GAS TRAIN] (mbar)

EK EVO 6.2400 GL-E

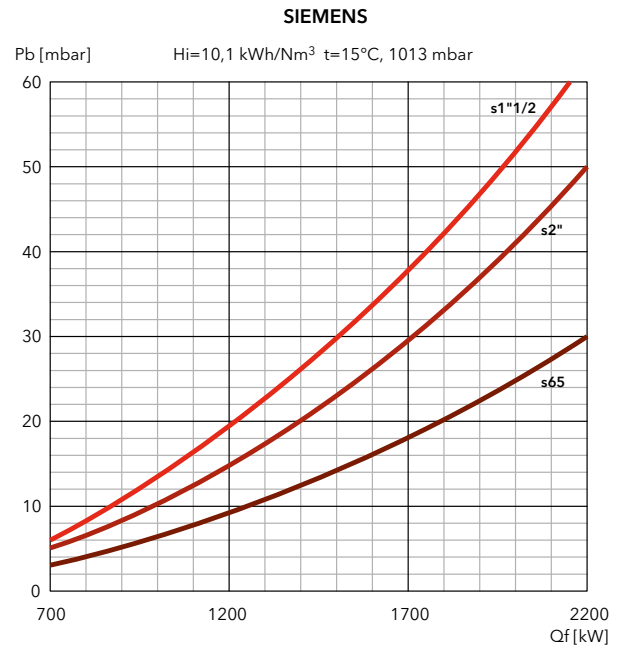
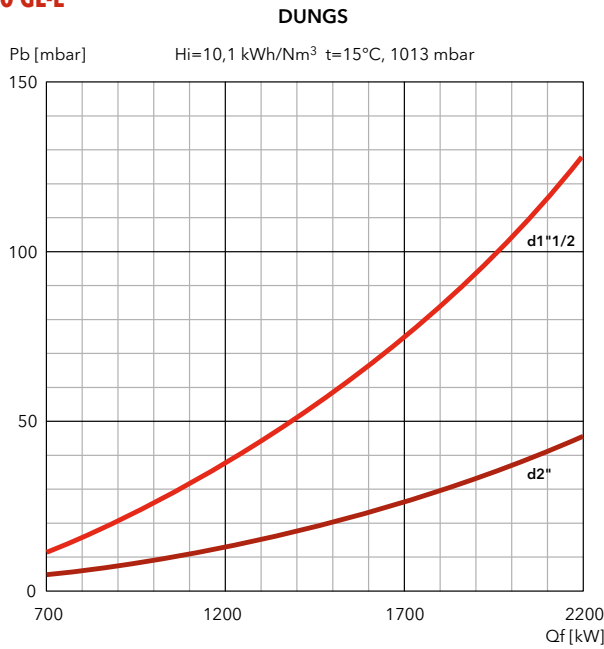

EK EVO 6.2900 GL-E

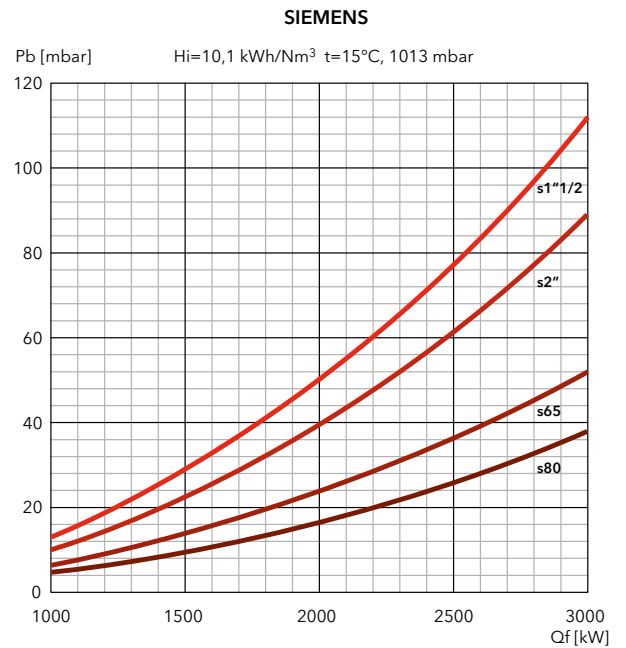
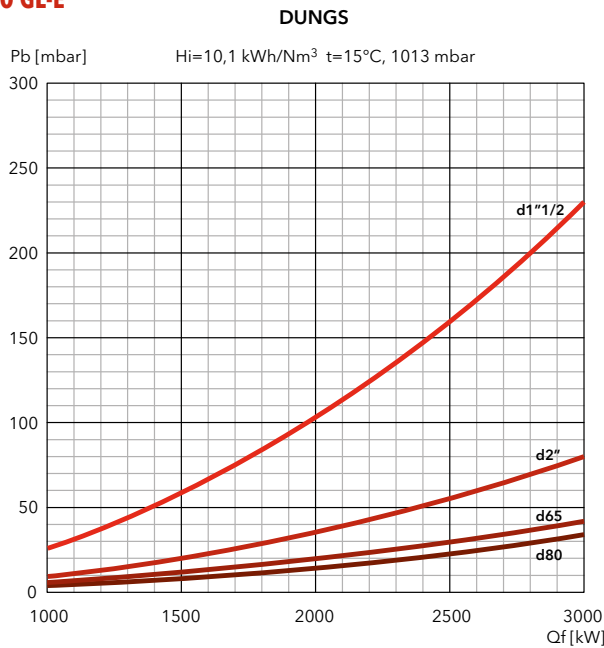

FILTERS

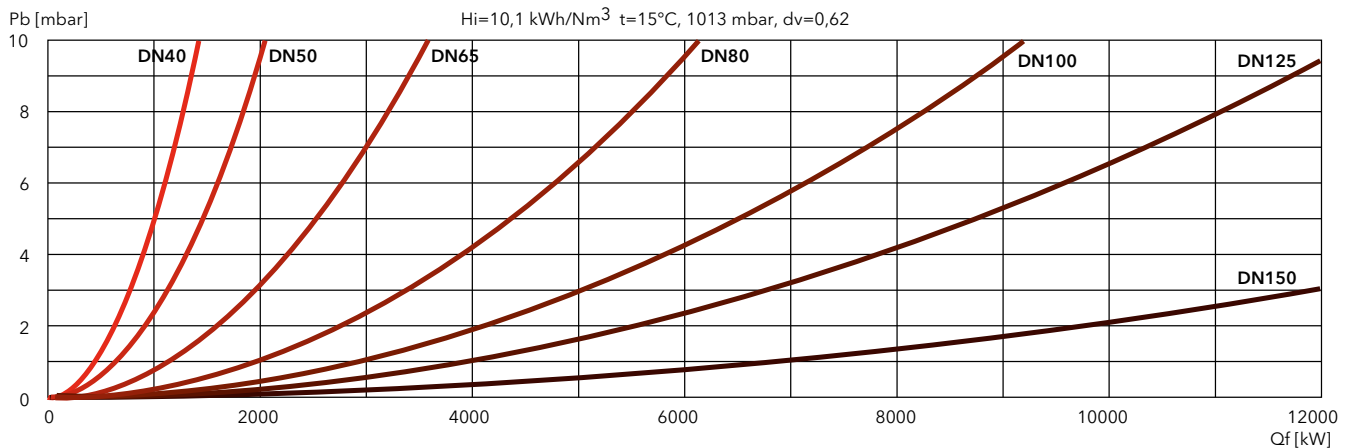



PRESSURE LOSS [BURNER HEAD + GAS TRAIN] (mbar)

EK EVO 7.3600 GL-E

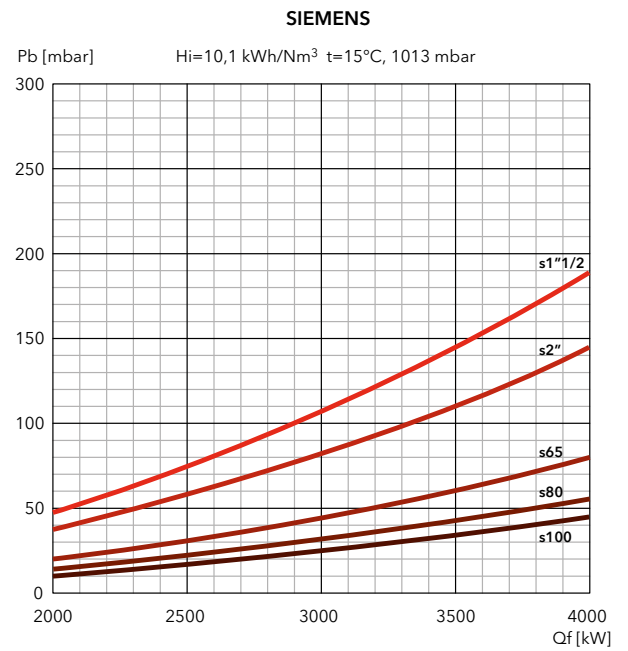
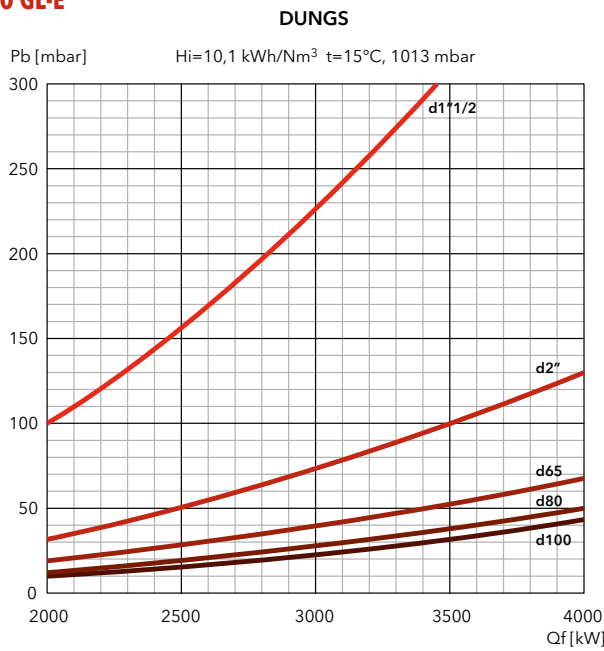

EK EVO 7.4500 GL-E

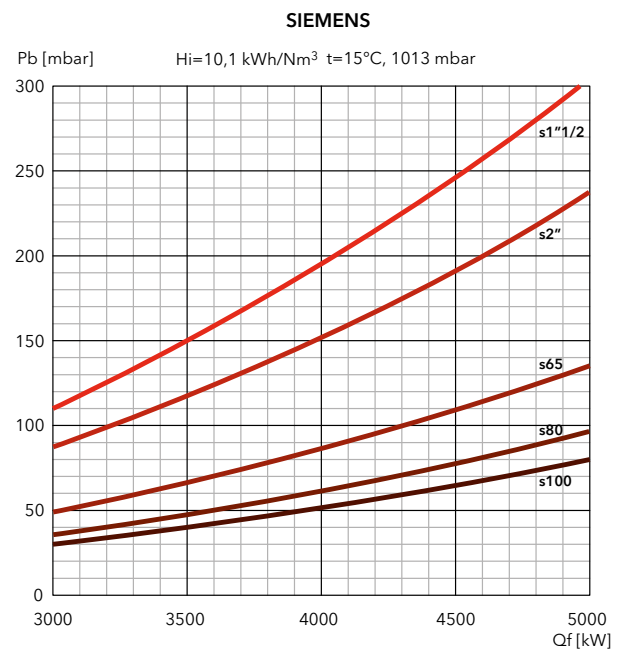
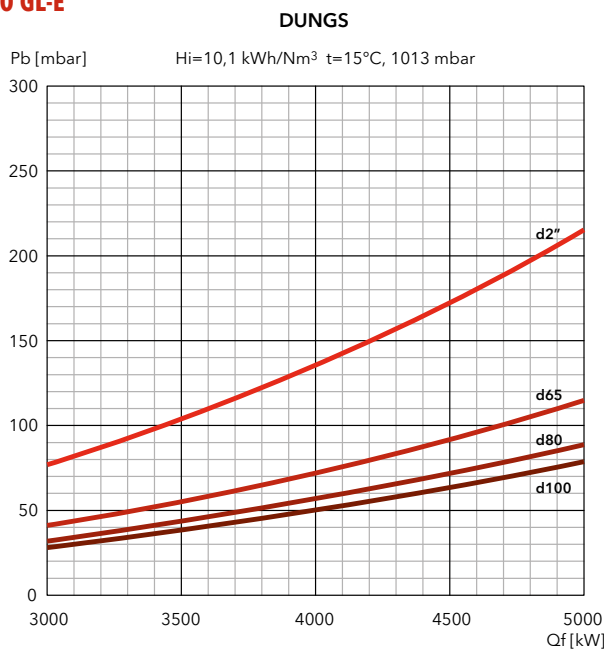

FILTERS

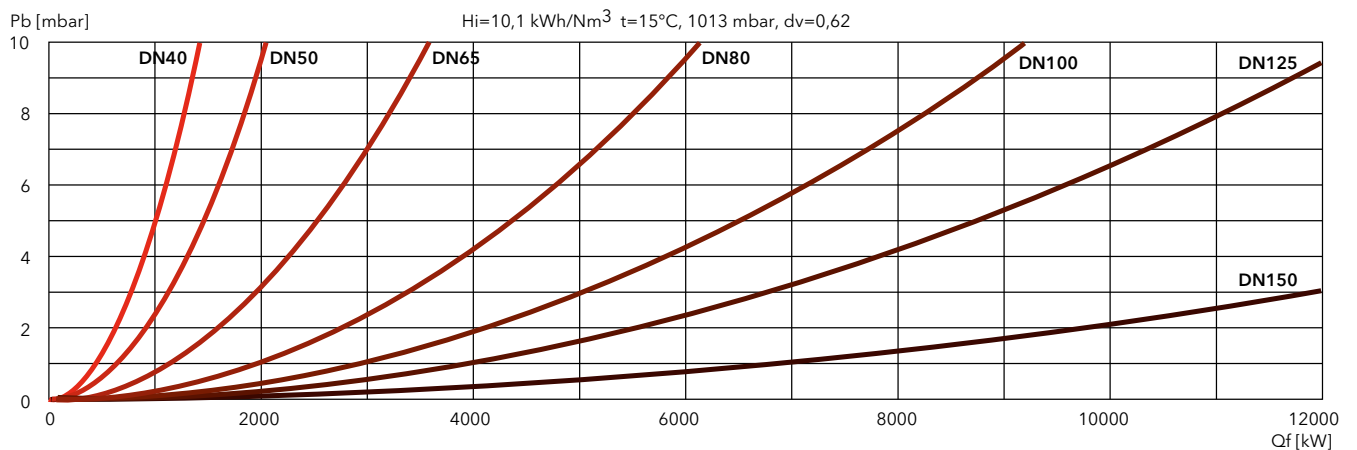

EKEVO 8 GL-E / EKEVO 9 GL-E

790 ... 10620 kW

Two stage progressive/modulating electronic in gas and in light oil



- **Fuels:** natural gas, Hi = 6,99 ... 11,39 kWh/Nm³;
light oil, viscosity 6 mm²/s at 20°C, Hi = 11,86 kWh/kg
- **Emission class:** Low NOx class 2 (≤120 mg/kWh) according to EN676 in gas
Low NOx class 2 (≤185 mg/kWh) according to EN267 in light oil
- **Protection level:** IP 41

TECHNICAL DATA

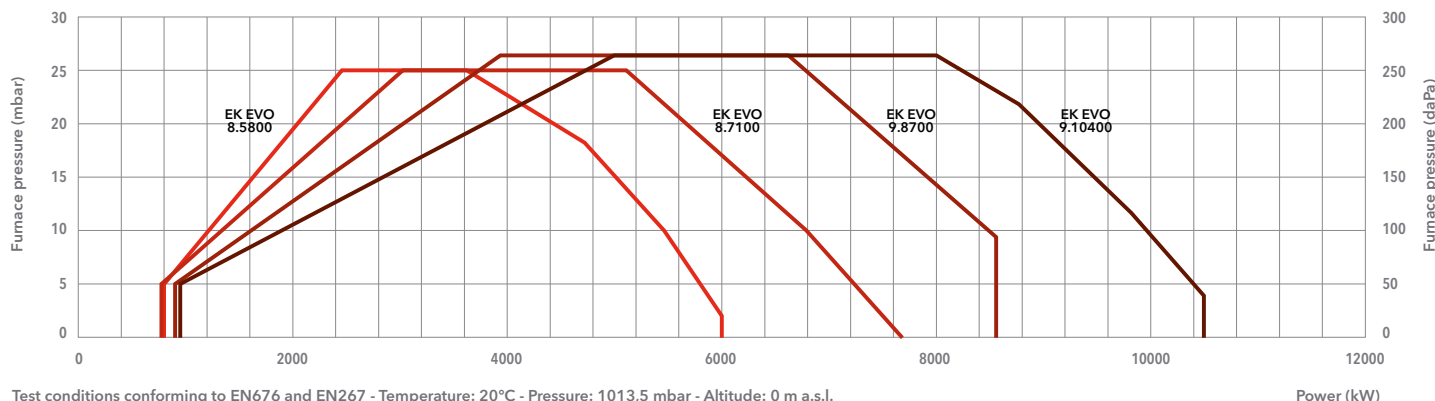

Test conditions conforming to EN676 and EN267 - Temperature: 20°C - Pressure: 1013,5 mbar - Altitude: 0 m a.s.l.

	EK EVO 8.5800 GL-E	EK EVO 8.7100 GL-E	EK EVO 9.8700 GL-E	EK EVO 9.10400 GL-E
Operating range gas	800 – 6000 kW	790 – 7700 kW	880 – 8530 kW	910 – 10620 kW
Operating range oil	1210 – 6000 kW	1450 – 7700 kW	2400 – 8530 kW	2820 – 10620 kW
Gas pressure	100 – 500 mbar (100 – 360 mbar for d457)		100 – 500 mbar (100 – 360 mbar for d457)	
Gas connection	DN100	DN100	DN100	DN100
Control box / flame detector	BT300 / QRA2	BT300 / QRA2	BT300 / QRA2	BT300 / QRA2
Auxiliary voltage	1NPE AC 230 V – 50 Hz TN-S	1NPE AC 230 V – 50 Hz TN-S	1NPE AC 230 V – 50 Hz TN-S	1NPE AC 230 V – 50 Hz TN-S
Power supply	3PE AC 400 V – 50 Hz	3PE AC 400 V – 50 Hz	3PE AC 400 V – 50 Hz	3PE AC 400 V – 50 Hz
Fan motor	50 Hz – 11 kW	50 Hz – 15 kW	50 Hz – 18,5 kW	50 Hz – 22 kW
Acoustic level	<80,5 dB(A)	<82,6 dB(A)	<85,5 dB(A)	<86,2 dB(A)
CE certificate	0085CL0215	0085CL0215	0085CL0215	0085CL0215
Burner codes (body + head)	KN	3754601	3754602	3754603
	KM	3754605	3754606	3754607
	KL	3754609	3754610	3754611

GAS TRAINS

DUNGS

Model	Code
GT-d457-2" (*)	3750515
GT-d458-65	3750516
GT-d459-80	3750517
GT-d460-100	3750518
GT-d125	on request

SIEMENS

Model	Code
GT-s456-1"1/2	3750536
GT-s457-2"	3750537
GT-s458-65	3750538
GT-s459-80	3750539
GT-s460-100	3750540
GT-s461-125	3750541

FILTERS

Model	Code
FG-Rp1"1/2	3757199
FG-Rp2"	3757200
FG-DN65	3757198
FG-DN80	3757201
FG-DN100	3757195
FG-DN125	3757209

*: integrated filter

i Pressure drops graphs: see following pages
Dimensions of gas trains and gas filters: see page 311



DIMENSIONS (mm)

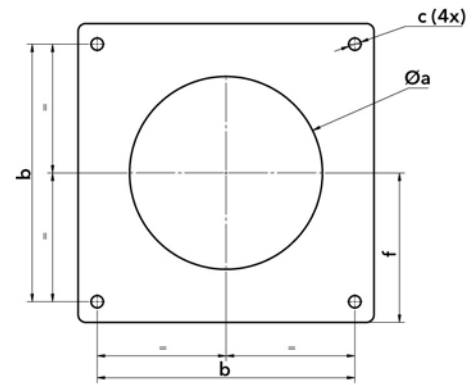
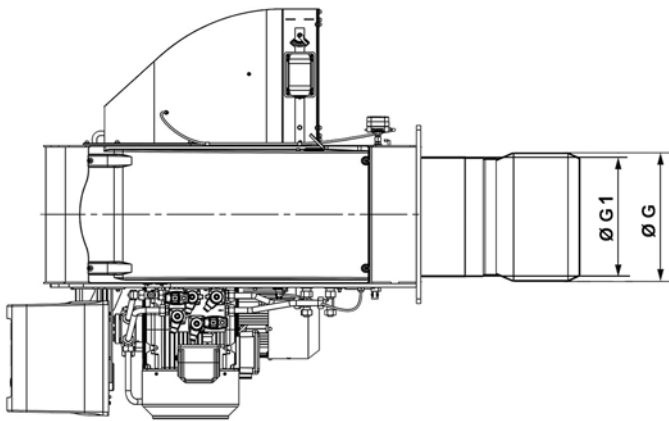
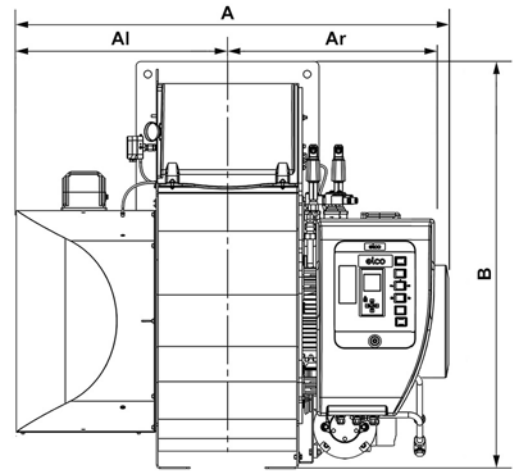
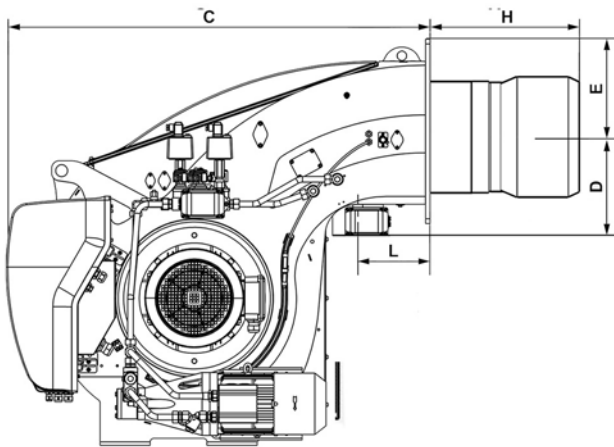

Model	A	Al	Ar	B	C	D	E	ØG	ØG1	H			L	Øa	b	c	f
										KN	KM	KL					
EKEVO 8.5800 GL-E	1325	670	655	1231	1351	391	307	400	369	562	702	842	230	430-480	505	M20	293
EKEVO 8.7100 GL-E	1325	670	655	1231	1351	391	307	415	369	583	723	863	230	445-480	505	M20	293
EKEVO 9.8700 GL-E	1336	670	666	1291	1348	332	288	431,5	438,5	353	503	653	230	445-480	505	M20	293
EKEVO 9.10400 GL-E	1400	670	731	1291	1348	332	293	431,5	438,5	353	503	653	230	445-480	505	M20	293

PACKAGING

The burner is delivered on a pallet with:

- burner body with mounted combustion head
- gas train and filter
- boiler fixing accessories
- technical documentation

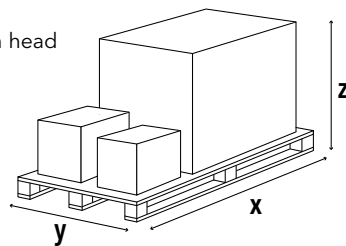

Model	Dimensions (mm)			Gross weight (kg)
	X	Y	Z	
EKEVO 8.5800 GL-E	2300	1500	1573	580
EKEVO 8.7100 GL-E	2300	1500	1573	580
EKEVO 9.8700 GL-E	2300	1500	1573	700
EKEVO 9.10400 GL-E	2300	1500	1573	700

EKEVO 8 GL-E / EKEVO 9 GL-E

790 ... 10620 kW

Two stage progressive/modulating electronic in gas and in light oil

PRESSURE LOSS [BURNER HEAD + GAS TRAIN] (mbar)

EKEVO 8.5800 GL-E

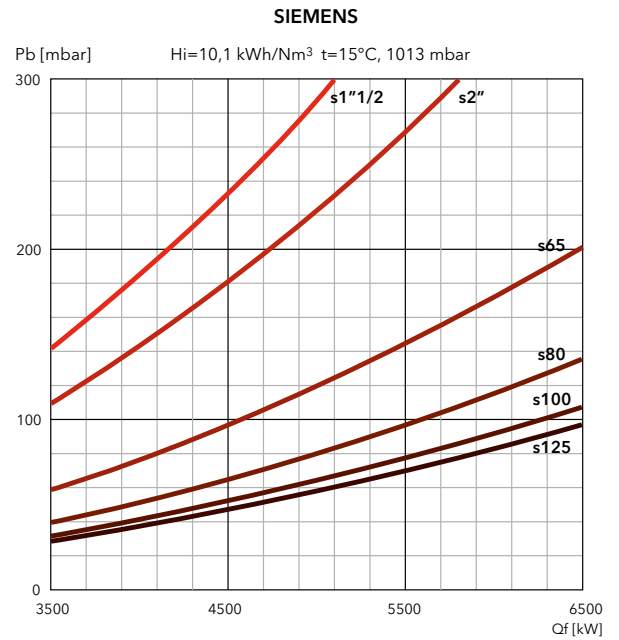
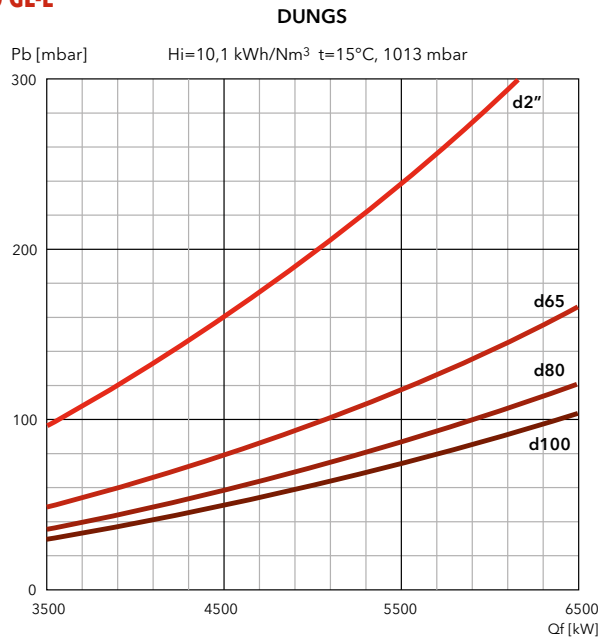

EKEVO 8.7100 GL-E

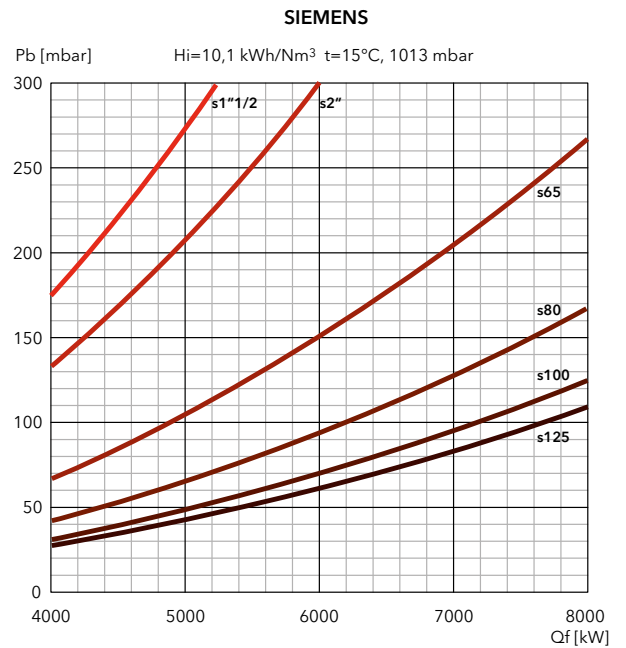
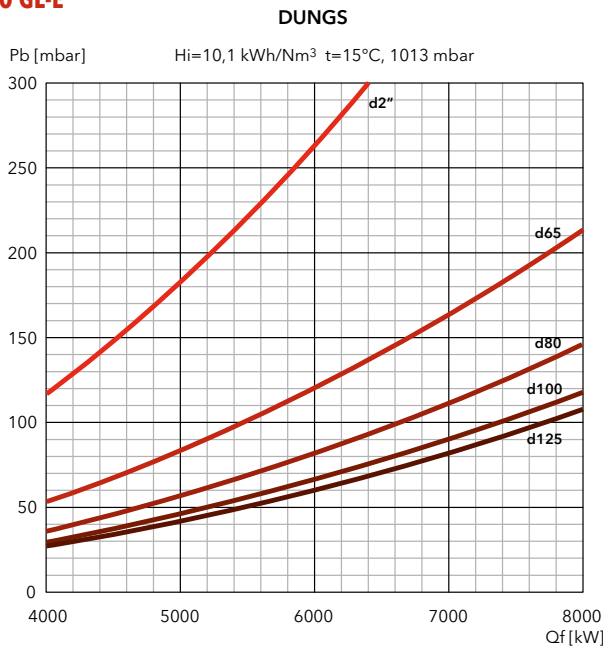

FILTERS

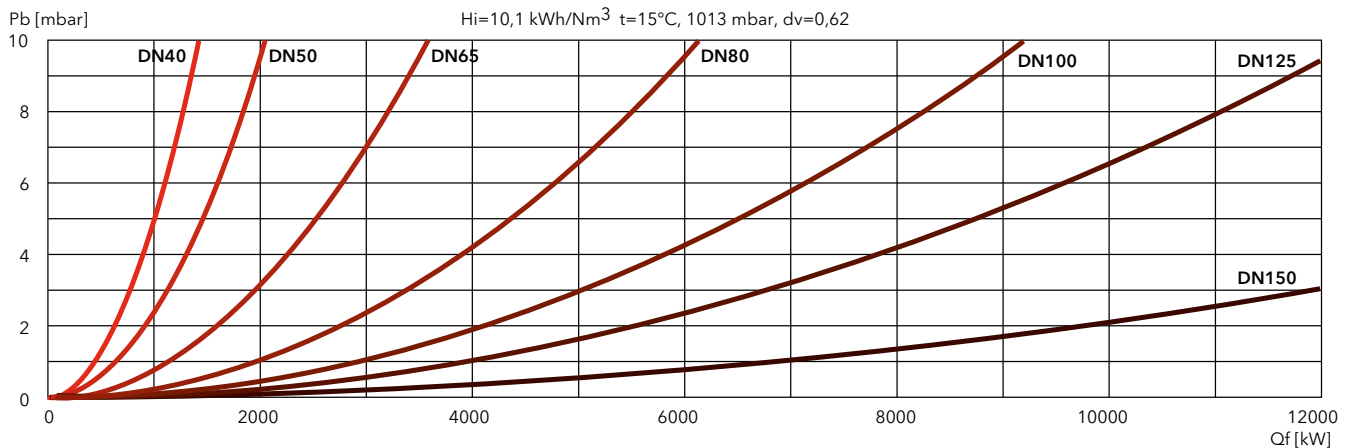



PRESSURE LOSS [BURNER HEAD + GAS TRAIN] (mbar)

EK EVO 9.8700 GL-E

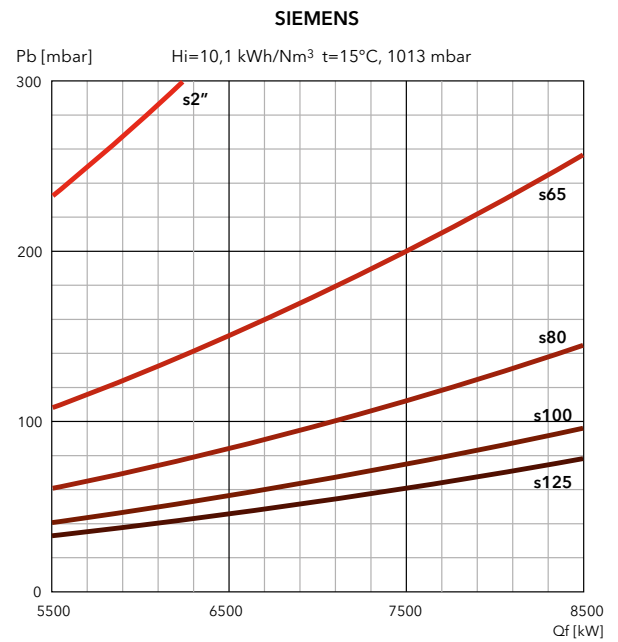
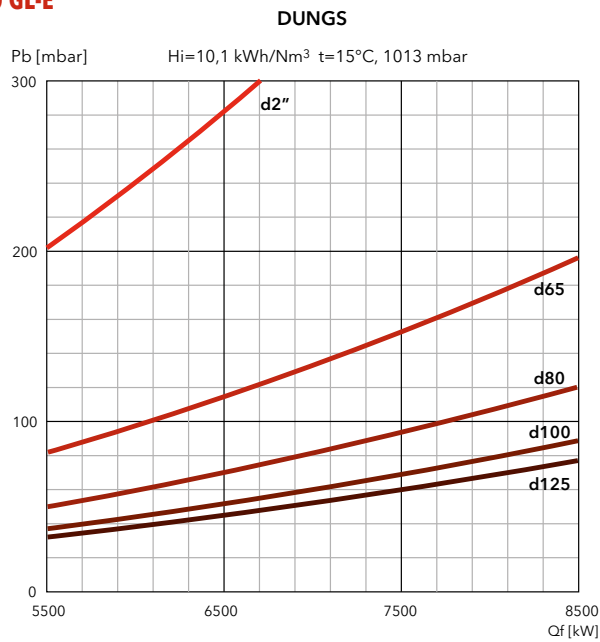

EK EVO 9.10400 GL-E

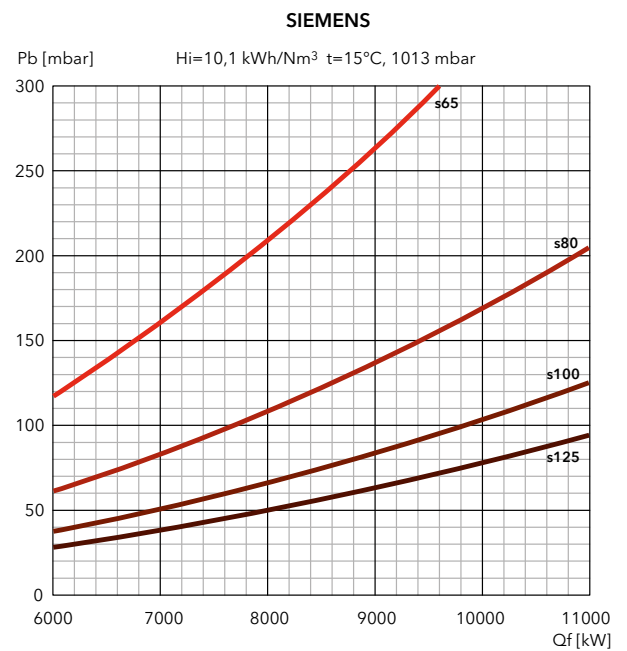
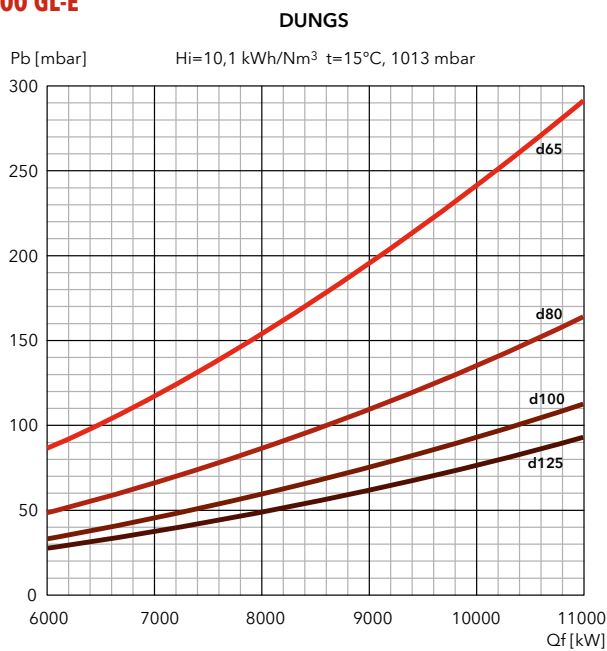

FILTERS

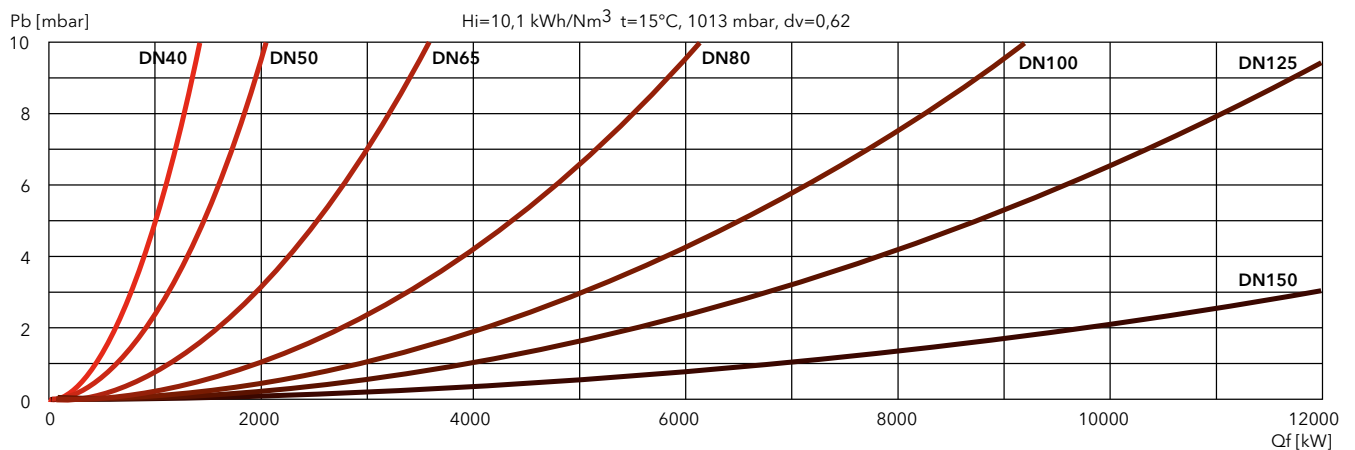

EKEVO 6 L-EF3 / EKEVO 7 L-EF3

360 ... 4820 kW

Two stage progressive/modulating electronic

- **Fuels:** light oil, viscosity 6 mm²/s at 20°C, Hi = 11,86 kWh/kg
- **Emission class:** Low NOx class 3 (≤120 mg/kWh) according to EN267
- **Protection level:** IP 41



TECHNICAL DATA

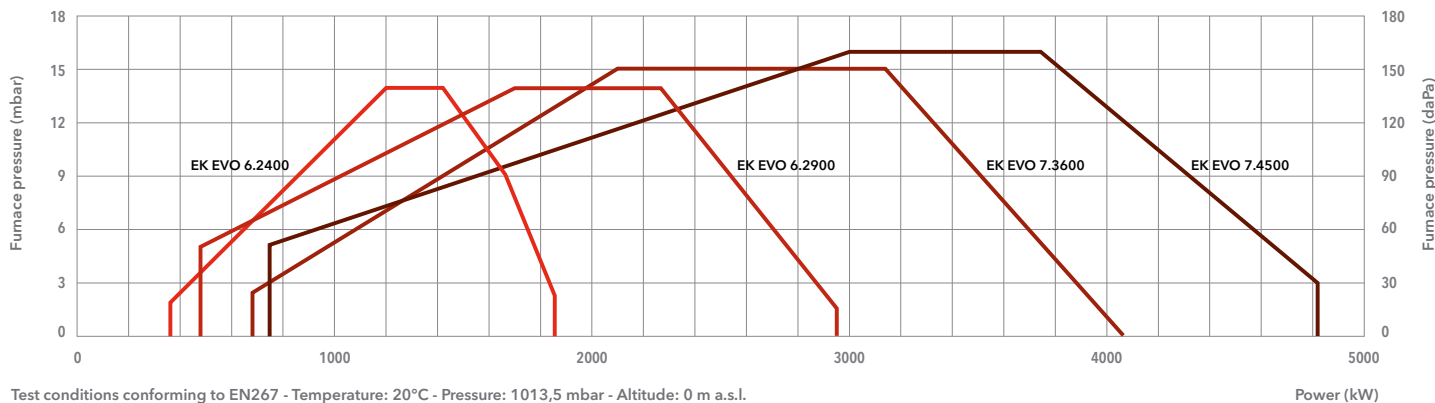

Test conditions conforming to EN267 - Temperature: 20°C - Pressure: 1013,5 mbar - Altitude: 0 m a.s.l.

	EK EVO 6.2400 L-EF3	EK EVO 6.2900 L-EF3	EK EVO 7.3600 L-EF3	EK EVO 7.4500 L-EF3
Operating range	360 – 1850 kW	480 – 2950 kW	680 – 4070 kW	740 – 4820 kW
Fuel connection	DN20 x 1500 mm / R 1/2"	DN20 x 1500 mm / R 1/2"	DN20 x 1500 mm / R 3/4"	DN20 x 1500 mm / R 3/4"
Auxiliary voltage	1NPE AC 230 V – 50 Hz TN-S	1NPE AC 230 V – 50 Hz TN-S	1NPE AC 230 V – 50 Hz TN-S	1NPE AC 230 V – 50 Hz TN-S
Power supply	3PE AC 400 V – 50 Hz	3PE AC 400 V – 50 Hz	3PE AC 400 V – 50 Hz	3PE AC 400 V – 50 Hz
Control box / flame detector	BT300 / FFS08	BT300 / FFS08	BT300 / FFS08	BT300 / FFS08
Fan motor	50 Hz – 3 kW	50 Hz – 4 kW	50 Hz – 7,5 kW	50 Hz – 7,5 kW
Pump	SUNTEC TA3	SUNTEC TA3	SUNTEC TA4	SUNTEC TA5
Motor pump	50 Hz – 0,75 kW	50 Hz – 0,75 kW	50 Hz – 1,1 kW	50 Hz – 1,5 kW
Acoustic level	<76 dB(A)	<77 dB(A)	<83 dB(A)	<81 dB(A)
CE certificate	0085CL0215	0085CL0215	0085CL0215	0085CL0215
Burner codes (body + head)	KN	3756774	3756775	3756776
	KM	3756779	3756780	3756781
	KL	3756783	3756784	3756785



DIMENSIONS (mm)

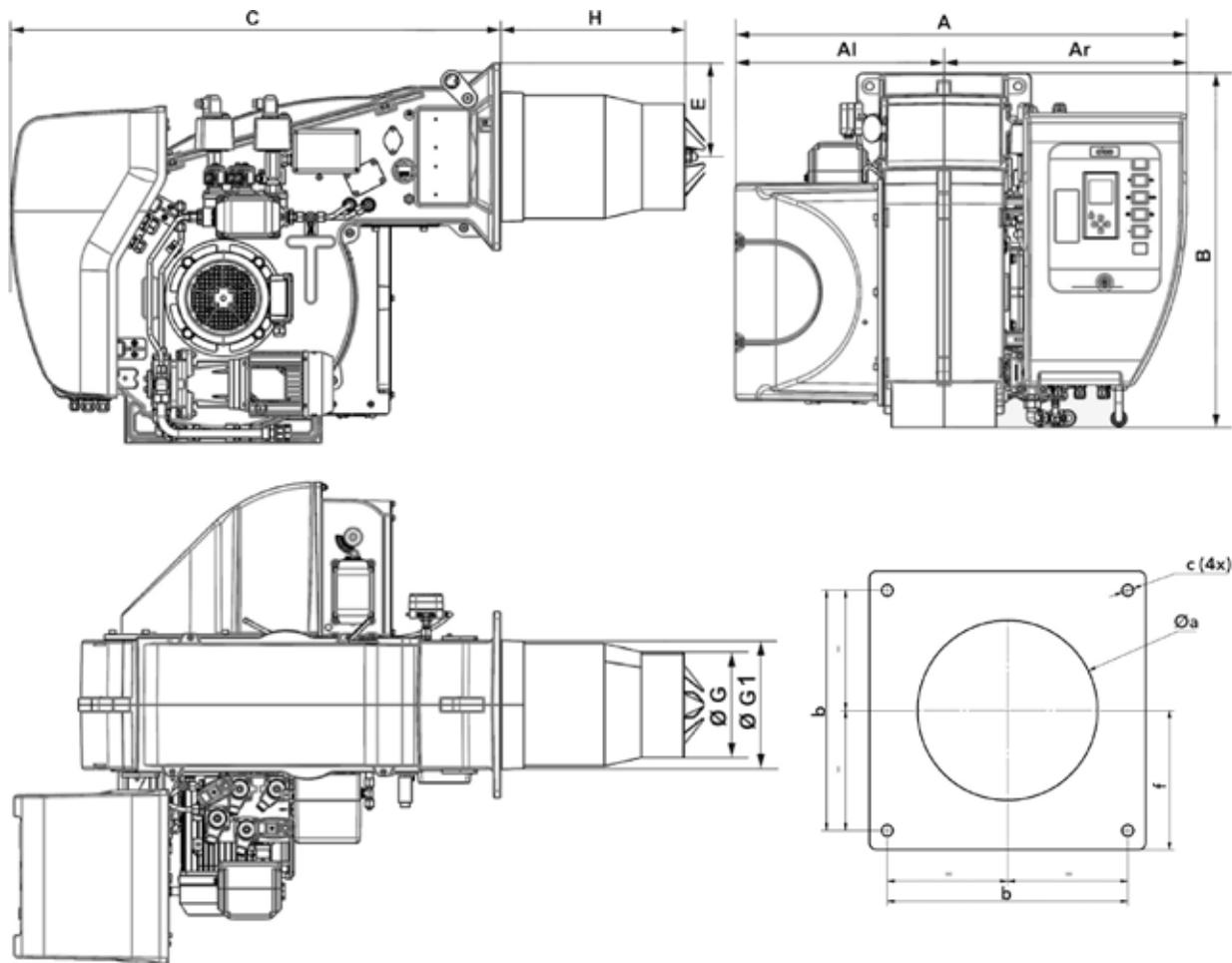

Model	A	Al	Ar	B	C	E	ØG	ØG1	H			Øa	b	c	f
									KN	KM	KL				
EK EVO 6.2400 L-EF3	1035	479	556	812	1046	200	227	290	400	520	640	300-340	340	M16	200
EK EVO 6.2900 L-EF3	1035	479	556	812	1046	200	263	290	400	520	640	300-340	340	M16	200
EK EVO 7... L-EF3	1107	510	597	941	1121	255	325	325	375	505	635	360-400	400	M16	235

PACKAGING

The burner is delivered on a pallet with:

- burner body with mounted combustion head
- boiler fixing accessories
- technical documentation

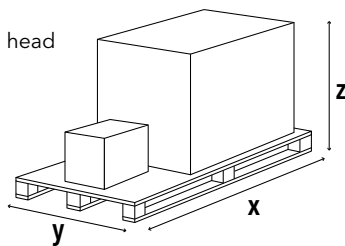

Model	Dimensions (mm)			Gross weight (kg)
	X	Y	Z	
EK EVO 6.2400 L-EF3	2046	1414	1233	300
EK EVO 6.2900 L-EF3	2046	1414	1233	300
EK EVO 7.3600 L-EF3	2046	1414	1233	350
EK EVO 7.4500 L-EF3	2046	1414	1233	350

EK EVO**LIGHT OIL****Low NOx Class 3****EKEVO 8 L-EF3 / EKEVO 9 L-EF3**

1100 ... 6600 kW

Two stage progressive/modulating electronic

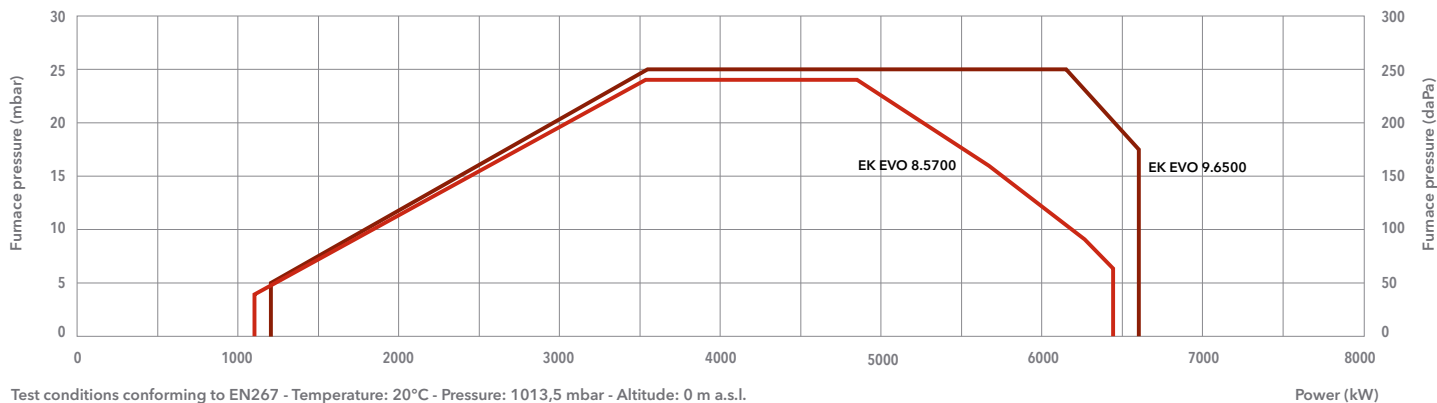

- **Fuels:** light oil, viscosity 6 mm²/s at 20°C, Hi = 11,86 kWh/kg
- **Emission class:** Low NOx class 3 (≤120 mg/kWh) according to EN267
- **Protection level:** IP 41

TECHNICAL DATA

Test conditions conforming to EN267 - Temperature: 20°C - Pressure: 1013,5 mbar - Altitude: 0 m a.s.l.

	EK EVO 8.5700 L-EF3	EK EVO 9.6500 L-EF3	
Operating range	1100 - 6450 kW	1200 - 6600 kW	
Fuel connection	DN20 x 1500 mm / R 3/4"	DN20 x 1500 mm / R 3/4"	
Auxiliary voltage	1NPE AC 230 V - 50 Hz TN-S	1NPE AC 230 V - 50 Hz TN-S	
Power supply	3PE AC 400 V - 50 Hz	3PE AC 400 V - 50 Hz	
Control box / flame detector	BT300 / FFS08	BT300 / FFS08	
Fan motor	50 Hz - 15 kW	50 Hz - 22 kW	
Pump	SMG1630 - 1700 l/h	SMG1630 - 1700 l/h	
Motor pump	50 Hz - 3 kW	50 Hz - 3 kW	
Acoustic level	<83,9 dB(A)	<87,9 dB(A)	
CE certificate	0085CL0215	0085CL0215	
Burner codes (body + head)	KN	3756799	3756800
	KM	3756803	3756804
	KL	3756807	3756808



DIMENSIONS (mm)

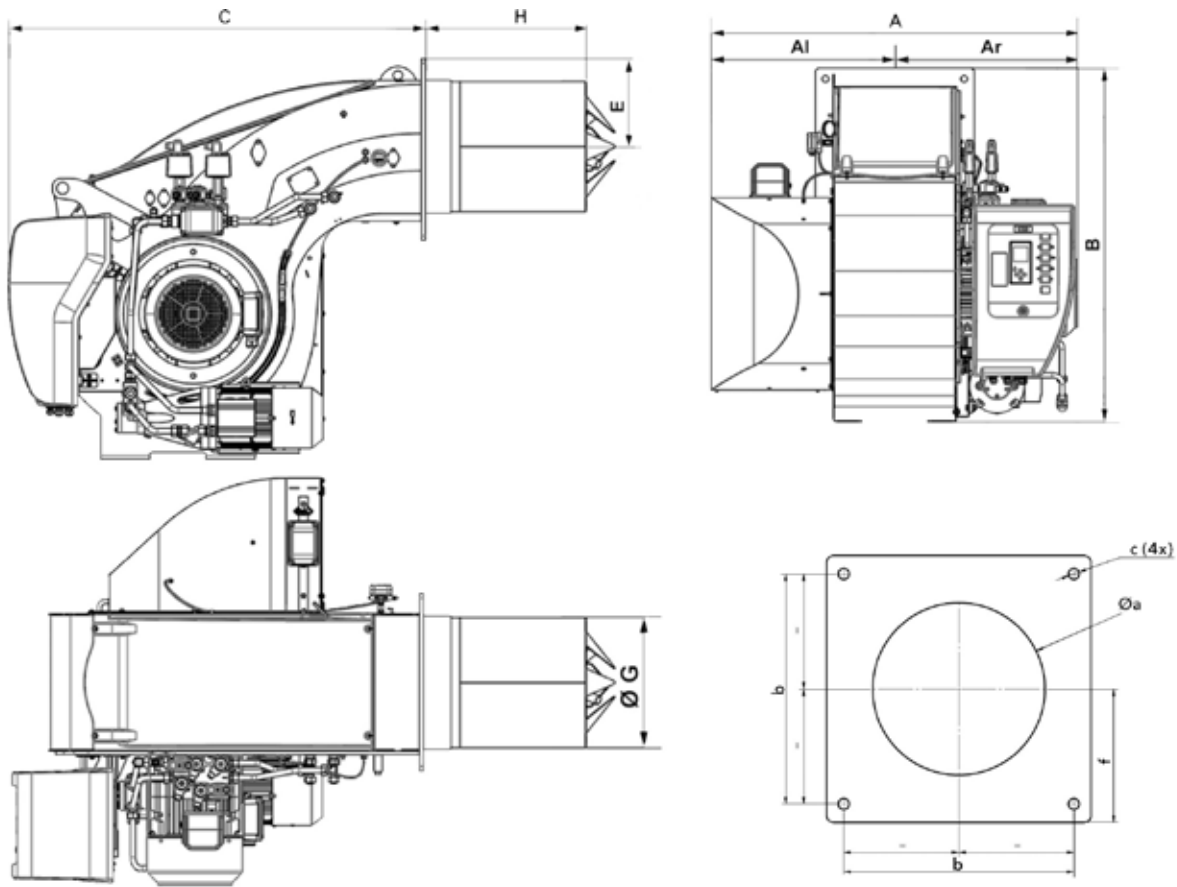

Model	A	Al	Ar	B	C	E	ØG	H			Øa	b	c	f
								KN	KM	KL				
EK EVO 8.5700 L-EF3	1325	670	655	1231	1351	293	369	528	668	808	380-410	505	M20	293
EK EVO 9.6500 L-EF3	1400	670	730	1291	1348	293	431,5	543	693	843	445-480	505	M20	293

PACKAGING

The burner is delivered on a pallet with:

- burner body with mounted combustion head
- boiler fixing accessories
- technical documentation

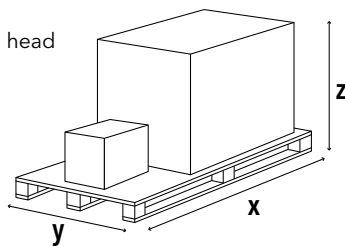

Model	Dimensions (mm)			Gross weight (kg)
	X	Y	Z	
EK EVO 8.5700 L-EF3	2300	1500	1573	580
EK EVO 9.6500 L-EF3	2300	1500	1573	700

EK EVO**LIGHT OIL****Low NOx Class 3****EKEVO 9 L-EUF****1800 ... 9570 kW****Two stage progressive/modulating electronic**

- **Fuels:** light oil, viscosity 6 mm²/s at 20°C, Hi = 11,86 kWh/kg
- **Emission class:** Low NOx class 3 (≤120 mg/kWh) according to EN267
- **Protection level:** IP 41

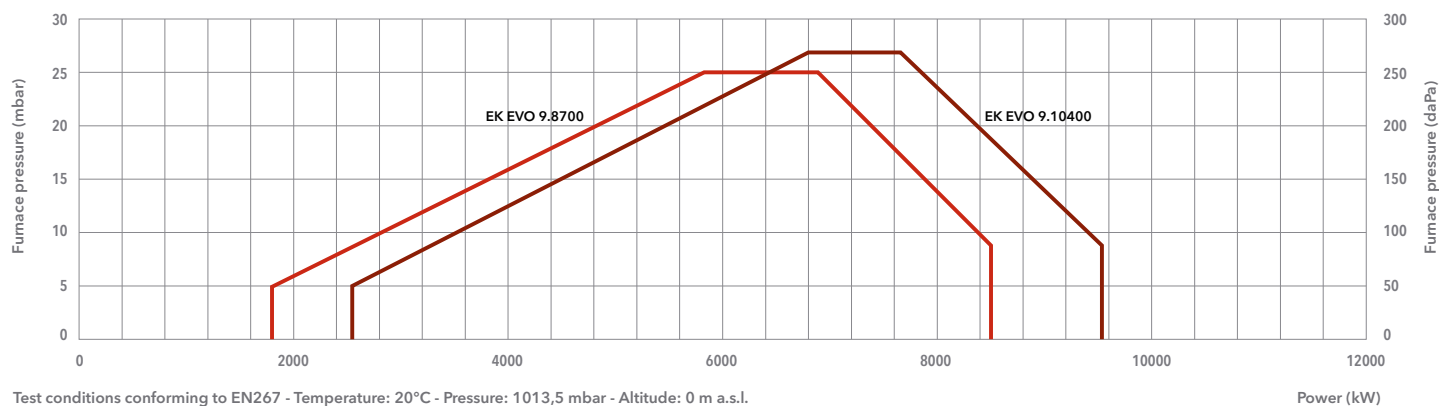
TECHNICAL DATA

	EK EVO 9.8700 L-EUF	EK EVO 9.10400 L-EUF
Operating range	1800 – 8500 kW	2550 – 9570 kW
Fuel connection	DN20 x 1500 mm / R 3/4"	DN25 x 1500 mm / R 1"
Auxiliary voltage	1NPE AC 230 V – 50 Hz TN-S	1NPE AC 230 V – 50 Hz TN-S
Power supply	3PE AC 400 V – 50 Hz	3PE AC 400 V – 50 Hz
Control box / flame detector	BT300 / FFS08	BT300 / FFS08
Fan motor	50 Hz – 18,5 kW	50 Hz – 22 kW
Pump	SMG1630 – 1700 l/h	SMG1631 – 2200 l/h
Motor pump	50 Hz – 3 kW	50 Hz – 4 kW
Acoustic level	<85,9 dB(A)	<86,6 dB(A)
CE certificate	0085CL0215	0085CL0215
Burner codes (body + head)	KN	3756801
	KM	3756805
	KL	3756809
		3756802
		3756806
		3756810



DIMENSIONS (mm)

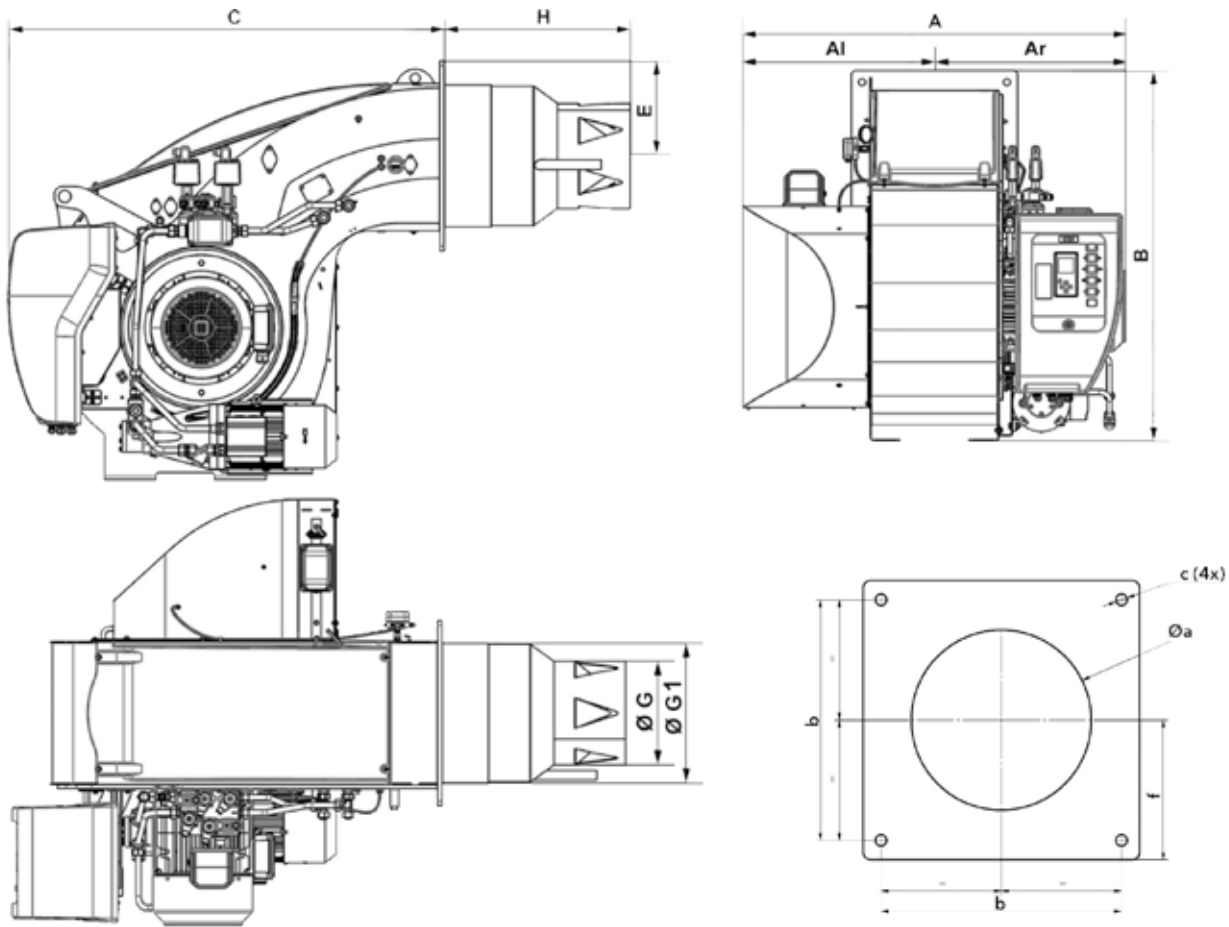

Model	A	Al	Ar	B	C	E	ØG	ØG1	H			Øa	b	c	f
									KN	KM	KL				
EK EVO 9.8700 L-EUF	1336	670	666	1291	1348	293	320	431,5	575	725	875	445-480	505	M20	293
EK EVO 9.10400 L-EUF	1400	670	730	1291	1348	293	330	431,5	575	725	875	445-480	505	M20	293

PACKAGING

The burner is delivered on a pallet with:

- burner body with mounted combustion head
- boiler fixing accessories
- technical documentation

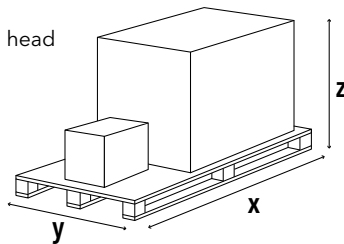

Model	Dimensions (mm)			Gross weight (kg)
	X	Y	Z	
EK EVO 9.8700 L-EUF	2300	1500	1573	700
EK EVO 9.10400 L-EUF	2300	1500	1573	700

EKEVO 6 L-E / EKEVO 7 L-E

510 ... 4900 kW

Two stage progressive/modulating electronic



- **Fuels:** light oil, viscosity 6 mm²/s at 20°C, Hi = 11,86 kWh/kg
- **Emission class:** Low NOx class 2 (≤185 mg/kWh) according to EN267
- **Protection level:** IP 41

TECHNICAL DATA

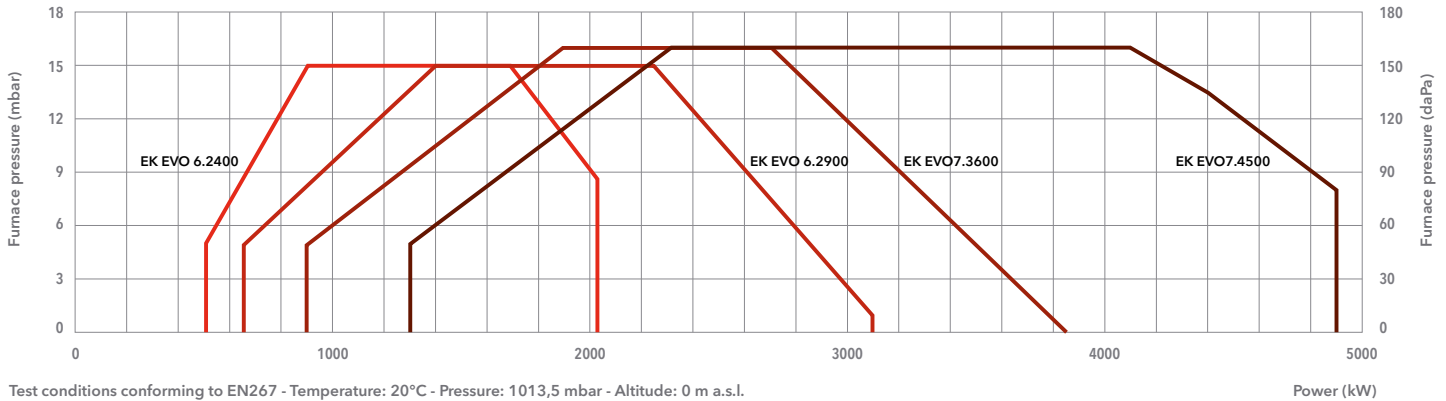

Test conditions conforming to EN267 - Temperature: 20°C - Pressure: 1013,5 mbar - Altitude: 0 m a.s.l.

	EK EVO 6.2400 L-E	EK EVO 6.2900 L-E	EK EVO 7.3600 L-E	EK EVO 7.4500 L-E
Operating range	510 – 2030 kW	650 – 3100 kW	900 – 3850 kW	1300 – 4900 kW
Fuel connection	DN20 x 1500 mm / R 1/2"	DN20 x 1500 mm / R 1/2"	DN20 x 1500 mm / R 3/4"	DN20 x 1500 mm / R 3/4"
Auxiliary voltage	1NPE AC 230 V – 50 Hz TN-S	1NPE AC 230 V – 50 Hz TN-S	1NPE AC 230 V – 50 Hz TN-S	1NPE AC 230 V – 50 Hz TN-S
Power supply	3PE AC 400 V – 50 Hz	3PE AC 400 V – 50 Hz	3PE AC 400 V – 50 Hz	3PE AC 400 V – 50 Hz
Control box / flame detector	BT300 / KLC20	BT300 / KLC20	BT300 / KLC20	BT300 / KLC20
Fan motor	50 Hz – 3 kW	50 Hz – 4 kW	50 Hz – 5,5 kW	50 Hz – 7,5 kW
Pump	SUNTEC TA3	SUNTEC TA3	SUNTEC TA4	SUNTEC TA5
Motor pump	50 Hz – 0,75 kW	50 Hz – 0,75 kW	50 Hz – 1,1 kW	50 Hz – 1,5 kW
Acoustic level	<77 dB(A)	<77 dB(A)	<81 dB(A)	<82,5 dB(A)
CE certificate	0085CL0215	0085CL0215	0085CL0215	0085CL0215
Burner codes (body + head)	KN	3756752	3756758	3756761
	KM	3756751	3756754	3756760
	KL	3756750	3756753	3756759



DIMENSIONS (mm)

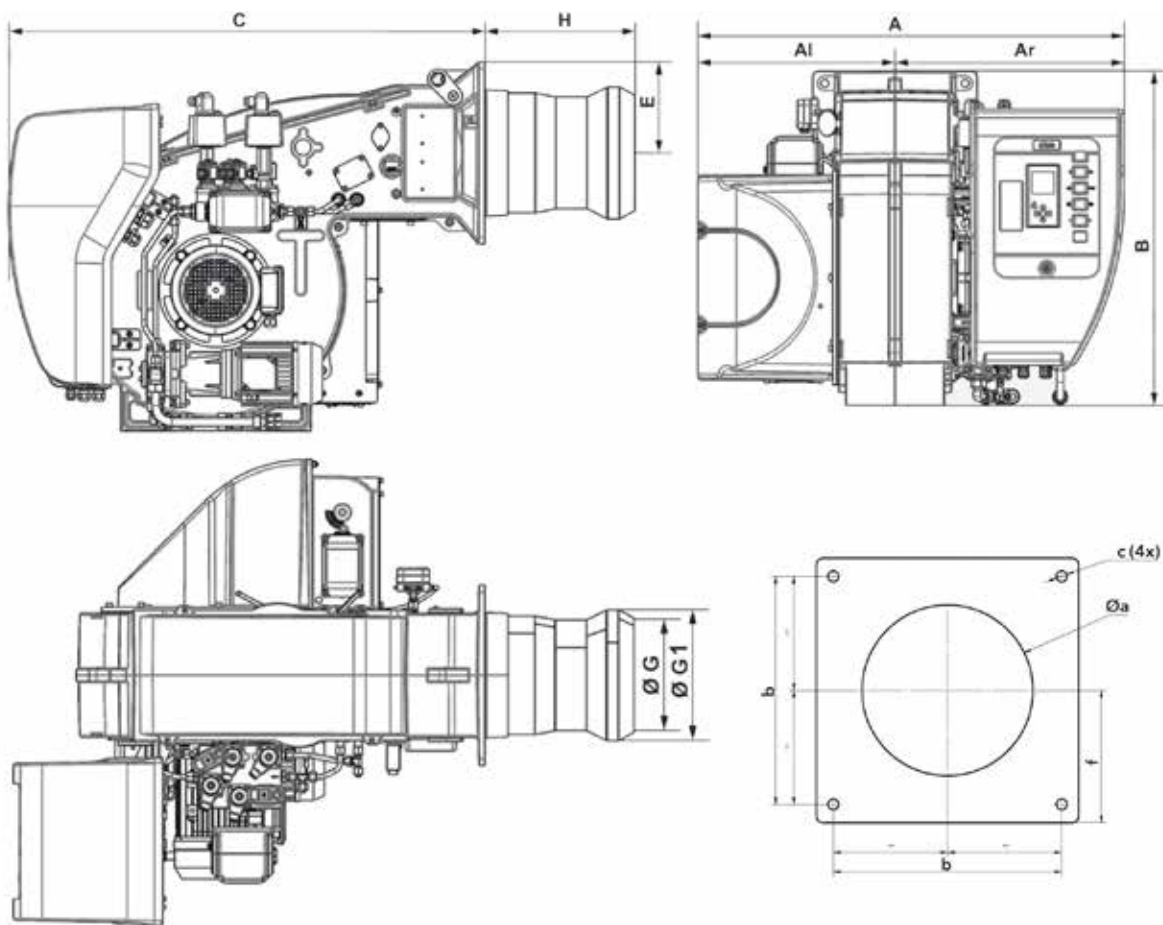

Model	A	Al	Ar	B	C	E	ØG	ØG1	H			Øa	b	c	f
									KN	KM	KL				
EK EVO 6.2400 L-E	1035	479	556	812	1046	200	250	290	330	450	570	300-340	340	M16	200
EK EVO 6.2900 L-E	1035	479	556	812	1046	200	265	310	330	450	570	320-340	340	M16	200
EK EVO 7.3600 L-E	1107	510	597	941	1121	235	280	340	375	505	635	340-400	400	M16	235
EK EVO 7.4500 L-E	1107	510	597	941	1121	235	310	370	375	505	635	380-400	400	M16	235

PACKAGING

The burner is delivered on a pallet with:

- burner body with mounted combustion head
- boiler fixing accessories
- technical documentation

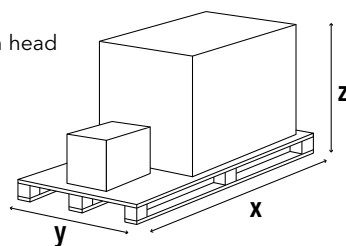

Model	Dimensions (mm)			Gross weight (kg)
	X	Y	Z	
EK EVO 6.2400 L-E	2046	1414	1233	300
EK EVO 6.2900 L-E	2046	1414	1233	300
EK EVO 7.3600 L-E	2046	1414	1233	350
EK EVO 7.4500 L-E	2046	1414	1233	350

EKEVO 8 L-E / EKEVO 9 L-E

1210 ... 10620 kW

Two stage progressive/modulating electronic



- **Fuels:** light oil, viscosity 6 mm²/s at 20°C, Hi = 11,86 kWh/kg
- **Emission class:** Low NOx class 2 (≤185 mg/kWh) according to EN267
- **Protection level:** IP 41

TECHNICAL DATA

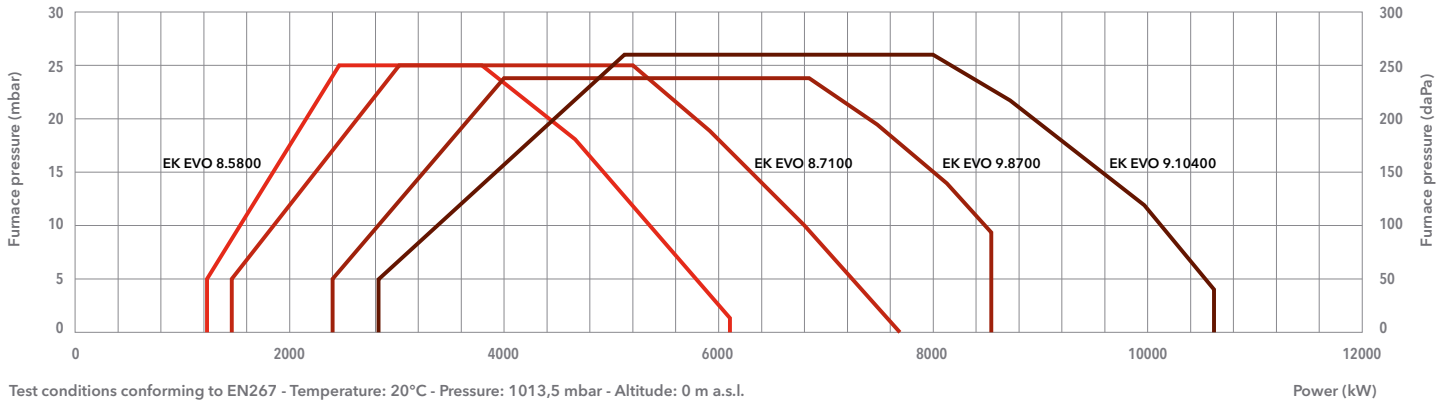

Test conditions conforming to EN267 - Temperature: 20°C - Pressure: 1013,5 mbar - Altitude: 0 m a.s.l.

	EK EVO 8.5800 L-E	EK EVO 8.7100 L-E	EK EVO 9.8700 L-E	EK EVO 9.10400 L-E
Operating range	1210 - 6100 kW	1450 - 7700 kW	2400 - 8530 kW	2820 - 10620 kW
Fuel connection	DN20 x 1500 mm / R 3/4"	DN20 x 1500 mm / R 3/4"	DN20 x 1500 mm / R 3/4"	DN25 x 1500 mm / R 1"
Auxiliary voltage	1NPE AC 230 V - 50 Hz TN-S	1NPE AC 230 V - 50 Hz TN-S	1NPE AC 230 V - 50 Hz TN-S	1NPE AC 230 V - 50 Hz TN-S
Power supply	3PE AC 400 V - 50 Hz	3PE AC 400 V - 50 Hz	3PE AC 400 V - 50 Hz	3PE AC 400 V - 50 Hz
Control box / flame detector	BT300 / KLC20	BT300 / KLC20	BT300 / KLC20	BT300 / KLC20
Fan motor	50 Hz - 11 kW	50 Hz - 15 kW	50 Hz - 18,5 kW	50 Hz - 22 kW
Pump	SMG1630 - 1700 l/h	SMG1630 - 1700 l/h	SMG1630 - 1700 l/h	SMG1631 - 2200 l/h
Motor pump	50 Hz - 3 kW	50 Hz - 3 kW	50 Hz - 3 kW	50 Hz - 4 kW
Acoustic level	<80,5 dB(A)	<82,6 dB(A)	<85,5 dB(A)	<86,2 dB(A)
CE certificate	0085CL0215	0085CL0215	0085CL0215	0085CL0215
Burner codes (body + head)	KN	3756764	3756770	3756773
	KM	3756763	3756769	3756772
	KL	3756762	3756765	3756771



DIMENSIONS (mm)

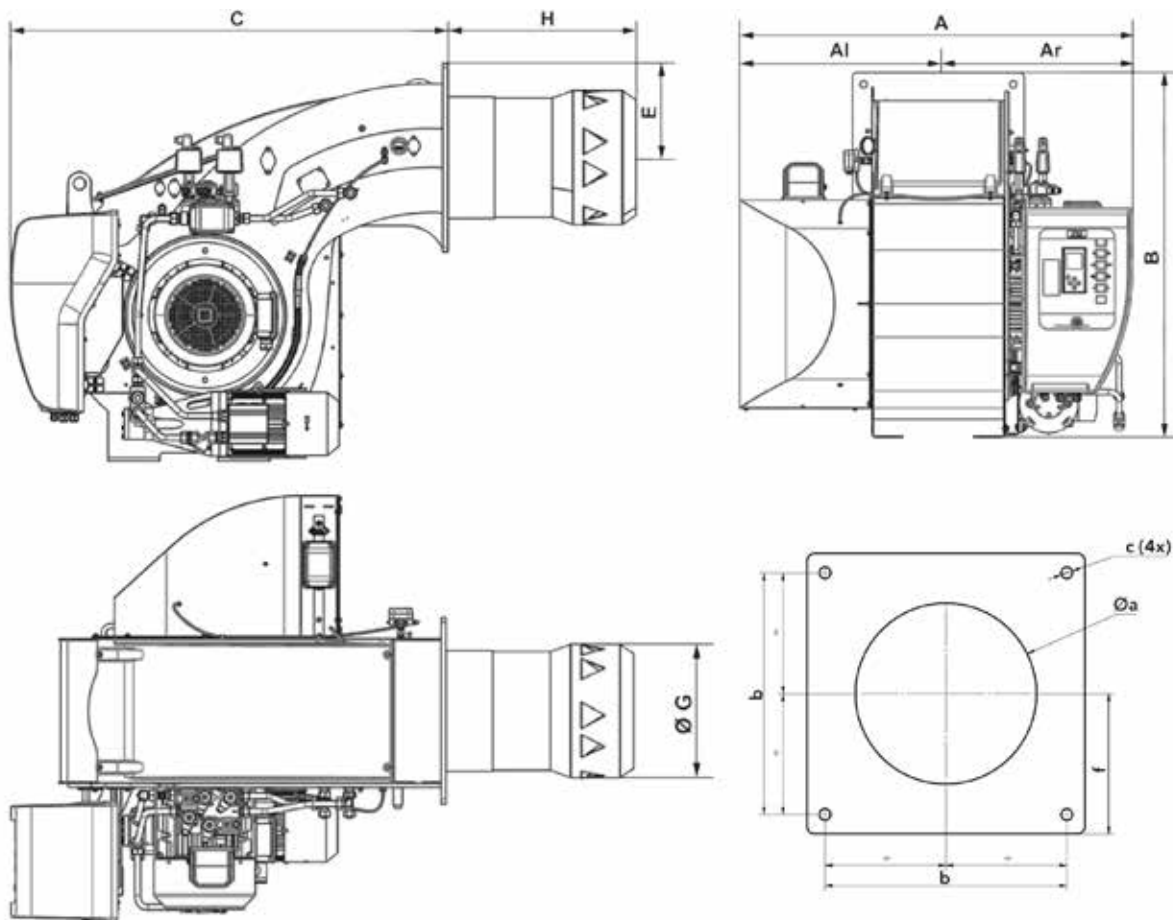

Model	A	Al	Ar	B	C	E	ØG	H			Øa	b	c	f
								KN	KM	KL				
EK EVO 8.5800 L-E	1325	670	655	1231	1351	293	400	562	702	842	430-480	505	M20	293
EK EVO 8.7100 L-E	1325	670	655	1231	1351	293	415	583	723	863	445-480	505	M20	293
EK EVO 9.8700 L-E	1325	670	655	1291	1348	293	431,5	355	505	655	445-480	505	M20	293
EK EVO 9.10400 L-E	1400	670	730	1291	1348	293	431,5	355	505	655	445-480	505	M20	293

PACKAGING

The burner is delivered on a pallet with:

- burner body with mounted combustion head
- boiler fixing accessories
- technical documentation

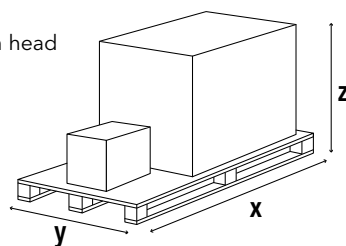

Model	Dimensions (mm)			Gross weight (kg)
	X	Y	Z	
EK EVO 8.5800 L-E	2300	1500	1573	580
EK EVO 8.7100 L-E	2300	1500	1573	580
EK EVO 9.8700 L-E	2300	1500	1573	700
EK EVO 9.10400 L-E	2300	1500	1573	700

LCM MODULE (for communication, O₂ control, frequency converter)

Module mounted in factory, requested for O ₂ control, Variatron and communication buses connections (the module is available also on request as a separate kit) Note: only one LCM module is necessary for these 3 options For all dual fuel models the LCM module is already included	3751645
---	---------

MODULATING OPERATION

RS55 (Regulator RWF55 + instruction manual), mounted in factory on the switch cabinet - to be connected to the appropriate probe (see "BURNER KITS" session)	for all models except EK EVO 6/7 GL-EZ3	3751646
	for EK EVO 6/7 GL-EZ3	3751647

FREQUENCY CONVERTER ARRANGEMENT

Burner prepared to be connected to an external frequency converter; this variant includes the VSM module to control the frequency converter.

NOTE: one LCM module is required and must be ordered separately

EK EVO 6.2400 G-E/G-EF3/G-EU2 prepared for an external frequency converter of 3 kW	3751673
EK EVO 6.2900 G-E/G-EF3/G-EU2 and EK EVO 6.2200 G-EU2N prepared for an external frequency converter of 4 kW	3751674
EK EVO 7.3600 G-E/G-EU2 prepared for an external frequency converter of 5,5 kW	3751675
EK EVO 7.3600 G-EF3, EK EVO 7.4500 G-E/G-EF3/G-EU2, EK EVO 7.3400 G-EU2N and EK EVO 7.4000 G-EFX prepared for an external frequency converter of 7,5 kW	3751676
EK EVO 7.5800 G-EF3 prepared for an external frequency converter of 11 kW	3757370
EK EVO 7.5800 G-EU2 and EK EVO 7.7000 G-EU2/G-EU3 prepared for an external frequency converter of 15 kW	3756304
EK EVO 8.5800 G-E/G-EU3 prepared for an external frequency converter of 11 kW	3754025
EK EVO 8.7100 G-E/G-EU3 and EK EVO 8.6600 G-EFX prepared for an external frequency converter of 15 kW	3754026
EK EVO 9.8700 G-E/G-EU3 prepared for an external frequency converter of 18,5 kW	3754027
EK EVO 9.10400 G-E/G-EU3, EK EVO 9.7200/7500 G-EU2N and EK EVO 9.7200/7400 G-EFX prepared for an external frequency converter of 22 kW	3754028
EK EVO 9.13000 G-EU2/G-EU3 and EK EVO 9.11300 G-EFX prepared for an external frequency converter of 37 kW	3756303
EK EVO 6.2400 GL-... prepared for an external frequency converter of 3 kW	3751677
EK EVO 6.2900 GL-... prepared for an external frequency converter of 4 kW	3751678
EK EVO 7.3600 GL-E/GL-EZ3 prepared for an external frequency converter of 5,5 kW	3751679
EK EVO 7.4500 GL-E/GL-EZ3 and EK EVO 7.3600/4500 GL-EF3 prepared for an external frequency converter of 7,5 kW	3751680
EK EVO 8.5800 GL-E prepared for an external frequency converter of 11 kW	3755057
EK EVO 8.7100 GL-E and EK EVO 8.5700 GL-EF3 prepared for an external frequency converter of 15 kW	3755058
EK EVO 9.8700 GL-E/GL-EUF prepared for an external frequency converter of 18,5 kW	3755059
EK EVO 9.10400 GL-E/GL-EUF and EK EVO 9.6500 GL-EF3 prepared for an external frequency converter of 22 kW	3755060

MAX GAS PRESSURE SWITCH (mounted on the gas train)

EK EVO 6/7	with Siemens threaded gas trains	3751669
	with Siemens flanged gas trains	3751670
	with Dungs threaded gas trains	3751671
	with Dungs flanged gas trains	3751672
EK EVO 8/9	with Siemens threaded gas trains	3754021
	with Siemens flanged gas trains	3754022
	with Dungs threaded gas trains	3754023
	with Dungs flanged gas trains	3754024

STAR/DELTA MOTOR STARTER

Star/Delta 4,0 G/BT3 for EK EVO 6.2200 G-EU2N and EK EVO 6.2900 G-.../GL-.../L-...	3751650
Star/Delta 5,5 G/BT3 for EK EVO 7.3600 G-E, GL-EZ3, GL-E and L-E	3751651
Star/Delta 7,5 G/BT3 for EK EVO 7.3400 G-EU2N, EK EVO 7.3600 G-EF3, GL-EF3, L-EF3 and EK EVO 7.4500 G-.../GL-.../L-...	3751652

PED EQUIPMENT

Equipment of the gas train and the burner body for continuous operation (PED):

- controller and flame sensor approved for continuous operation,
- maximum gas pressure switch on the gas train,
- test burner (to bleed the gas train),
- PED Conformity Declaration.

Note: if required, the antivibrating coupling (to avoid mechanical tension) has to be selected as option

PED for EK EVO 6/7 G-E	with Siemens threaded gas trains	3751653
	with Siemens flanged gas trains	3751654
	with Dungs threaded gas trains	3751655
	with Dungs flanged gas trains	3751656
PED for EK EVO 6/7 G-EF3	with Siemens threaded gas trains	3751665
	with Siemens flanged gas trains	3751666
	with Dungs threaded gas trains	3751667
	with Dungs flanged gas trains	3751668
PED for EK EVO 8/9 G-E and EK EVO 8/9 G-EU3 (except for model 9.13000)	with Siemens threaded gas trains	3754010
	with Siemens flanged gas trains	3754011
	with Dungs threaded gas trains	3754019
	with Dungs flanged gas trains	3754020
PED for EK EVO 6...9 G-EU2/-EU2N and EK EVO 9.13000 G-EU2/-EU3	with Siemens threaded gas trains	3756265
	with Siemens flanged gas trains	3756264
	with Dungs threaded gas trains	3756263
	with Dungs flanged gas trains	3756262
PED for EK EVO 6/7 GL-EZ3 and EK EVO 6/7 GL-E	with Siemens threaded gas trains	3751657
	with Siemens flanged gas trains	3751658
	with Dungs threaded gas trains	3751659
	with Dungs flanged gas trains	3751660
PED for EK EVO 8/9 GL-E	with Siemens threaded gas trains	3755055
	with Siemens flanged gas trains	3755056
	with Dungs threaded gas trains	3755053
	with Dungs flanged gas trains	3755054
PED for EK EVO 6/7 GL-EF3	with Siemens threaded gas trains	3755067
	with Siemens flanged gas trains	3755068
	with Dungs threaded gas trains	3755065
	with Dungs flanged gas trains	3755066
PED for EK EVO 8/9 GL-EF3/GL-EUF	with Siemens threaded gas trains	3755063
	with Siemens flanged gas trains	3755064
	with Dungs threaded gas trains	3755061
	with Dungs flanged gas trains	3755062
PED for EK EVO 6...9 L-E		3757269
PED for EK EVO 6...9 L-EU3/L-EUF		3757270
PED for EK EVO 6...9 G-... equipped with FGR System	with Siemens threaded gas trains	3756269
	with Siemens flanged gas trains	3756268
	with Dungs threaded gas trains	3756267
	with Dungs flanged gas trains	3756266

O₂ TRIM FOR BT300, ETAMATIC AND ETAMATIC OEM, FMS/VMS

This kit is used to optimize the combustion in order to keep the air excess as much stable as possible irrespective of the changes that can occur during operations, for instance slight calorific value variations, combustion air temperature and pressure. This improves the seasonal efficiency and therefore reduces the fuel consumption.

The kit includes the following components:

- Lambda transmitter LT3
- Lambda probe LS2
- Probe installation fitting (PIF)
- Gas extraction device (GED)

The control unit has to be installed close to the probe (max 10 m of cable)
 The probe needs a calibration but no reference gas is necessary.
 The display shows the O₂ content.
 Maximum distance between the LT3 and the burner control panel is 500 m.

	Additional LSB modules installed at LT3	GED length	Code
Kit for O₂ trim (LT3 + LS2) Flue temp max 300 °C - Display for O₂ visualization (Note: for models equipped with BT3 this kit needs a LCM module installed in the burner control panel)	none	150 mm	3759296
		300 mm	3759297
		450 mm	3759298
	4x 0/4-20 mA output	150 mm	3759299
		300 mm	3759300
		450 mm	3759301
	4x 0/4-20 mA output + 4x digital output	150 mm	3759302
		300 mm	3759303
		450 mm	3759304

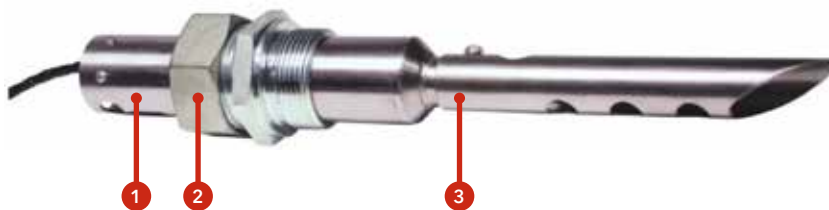

1. Lambda Probe LS2 in standard housing up to 300°C (572°F); default cable length is 2 m (6.5 ft), FEP, with connecting plug
2. Probe installation fitting (PIF)
3. Gas extraction device (GED)

The LS2 lambda probe is equipped with a 2 meter long connection cable that connects the sensor to the transmitter (LT3). It is possible to extend the connection up to a maximum distance of 10 meters (for greater lengths the conformity expires) with a ready-made cable and a probe connection box (PCB).

Description		Code
Extension for LS2	5m ready-made cable	3759318
	PCB (probe connection box)*	3759319

The PCB is a small terminal box that is connected to the 2 meter long cable already existing on the probe. The wiring between the PCB and the transmitter must be carried out on the construction site with suitable cables and trained personnel.

*: the PCB is mandatory if the end user chooses to use his own connecting cable and not one of those proposed (max total length remains 10m)

O₂/CO_e TRIM FOR BT300, ETAMATIC AND ETAMATIC OEM, FMS/VMS

This kit is used for optimizing the combustion in order to keep the air excess as low as possible in order to maximize the seasonal efficiency and therefore minimize the fuel consumption. In addition to the features of the O₂ trim only, this kit reduces the air excess to its minimum because this system continuously measures the content of unburned fuel (CO_e) in the flue: should the air excess be reduced too much, the CO_e raises and the system reacts by increasing the air excess in order to keep firing in safe conditions.

The kit includes the following components:

- Lambda transmitter LT3-F
- Lambda probe KS1D
- Probe installation fitting (PIF)
- Gas extraction device (GED)

The control unit has to be installed close to the probe (max 10 m of cable). The probe needs a calibration but no reference gas is necessary. The display shows the O₂ and CO_e content. Maximum distance between the LT3-F and the burner control panel is 500 m.

	Additional LSB modules installed at LT3-F	GED length	Code
Kit for O₂ trim and CO control (LT3-F + KS1D) Flue temp max 300 °C (Note: for models equipped with BT3 this kit needs a LCM module installed in the burner control panel)	none	150 mm	3759305
		300 mm	3759306
		450 mm	3759307
	4x 0/4-20 mA output	150 mm	3759308
		300 mm	3759309
		450 mm	3759310
	4x 0/4-20 mA output + 4x digital output	150 mm	3759311
		300 mm	3759312
		450 mm	3759313

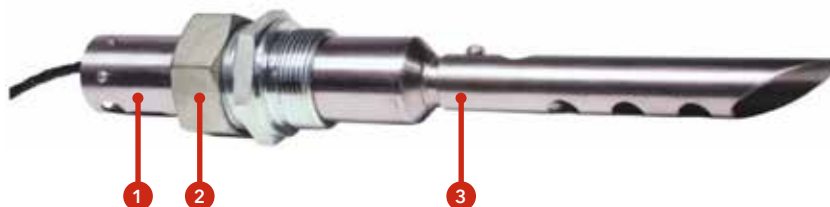

1. Lambda Probe KS1D in standard housing up to 300°C (572°F); default cable length is 2 m (6.5 ft), FEP, with connecting plug
2. Probe installation fitting (PIF)
3. Gas extraction device (GED)

The KS1D lambda probe is equipped with a 2 meter long connection cable that connects the sensor to the transmitter (LT3-F). It is possible to extend the connection up to a maximum distance of 10 meters (for greater lengths the conformity expires) with a ready-made cable and a probe connection box (PCB).

Description		Code
Extension for KS1D	5m ready-made cable	3759318
	PCB (probe connection box)*	3759319

The PCB is a small terminal box that is connected to the 2 meter long cable already existing on the probe. The wiring between the PCB and the transmitter must be carried out on the construction site with suitable cables and trained personnel.

*: the PCB is mandatory if the end user chooses to use his own connecting cable and not one of those proposed (max total length remains 10m)

REMOTE SOFTWARE

Kit to connect a PC laptop to the BT300 for its parametrization	LSA100 + USB/CAN + CD-Rom	3751130
---	---------------------------	---------

COMMUNICATION MODULES

Modules for external installation Note: LCM module is required	ModBus/BT3 (EBM100)	3754456
	ProfiBus/BT3 (PBM100)	3752986
	Profinet/BT3 (EBM112)	3758317
	Ethernet/BT3	on request

POWER REGULATOR

Power regulator RWF55 stand-alone and kit wiring	3753358
--	---------

PROBES

Immersion probes	PT 100: -50°/+400°C (100 mm) + pocket tube (76 mm)	3750070
	PT 100: 400°C (160 mm)	1758574269
	PT 100: 480°C (250 mm)	3751009
Pressure probes	0...1,6 bar	3752217
	0...2,5 bar	1758713722
	0...6 bar	1758640660
	0...10 bar	1758577280
	0...16 bar	1758577291
	0...25 bar	3751015

EXTERNAL AIR INLET CONNECTION KIT

Connection for external air channel for EK EVO 6/7	3752987
Connection for external air channel for EK EVO 8/9	3754031

MAX GAS PRESSURE SWITCH KIT

Kit for EK EVO 6/7	with Siemens threaded gas trains	3754457
	with Siemens flanged gas trains	3754458
	with Dungs threaded gas trains	3754457
	with Dungs flanged gas trains	3754458
Kit for EK EVO 8/9	with Siemens threaded gas trains	3755095
	with Siemens flanged gas trains	3755096
	with Dungs threaded gas trains	3755095
	with Dungs flanged gas trains	3755096

HYDRAULIC MANOMETER KIT

Kit for EK EVO 6/7 GL-EZ3	3754440
Kit for EK EVO 6/7 GL-E/-EF3 and L-E/-EF3	3754634
Kit for EK EVO 8/9 GL-.../L-...	3754613

SPECIAL PACKAGING KIT (WOODEN BOX)

Wooden Box for EK EVO 6/7	3755020
Wooden Box for EK EVO 8	3754029
Wooden Box for EK EVO 9	on request

ACOUSTIC SHROUDS

See page 321 for sizes and information

- Equipment according EN746-2
- Permanent ventilation
- 60 Hz versions
- Remote display (BT3)
- Separate switch box / terminal strip version (Etamatic OEM)
- LPG firing
- Hinge flange
- "Burner ON" feedback signal

Other special requests can be submitted to your Sales Reference for feasibility evaluation

NEXTRON

MONOBLOCK BURNERS
FROM 250 TO 11200 kW
GAS, LIGHT OIL AND DUAL FUEL



DESIGN: SMOOTH AND INTEGRAL

The original design of NEXTRON range is the result of a successful integration between burner and ELCO technologies.

NEXTRON burners are able to perfectly integrate themselves in any installation and professionals will appreciate the innovative construction structure that ease maintenance.

UNIQUE LOW NO_x PERFORMANCE

Developed and improved by ELCO R&D department, the Free Flame and the Diamond Head technologies are unique combustion processes; the new Blue Triple Head allows you to reach even lower NO_x levels, guaranteeing values below 60 mg/kWh.

These ELCO technologies are capable to reach the NO_x levels required by the most severe standards for all types of combustion chambers, whether they are 3-pass or reverse pass boilers.

HIGH ACOUSTIC COMFORT

The NEXTRON burner range offers a high acoustic comfort thanks to the Low Noise System.

The unique air intake channel is carefully designed to achieve an acoustic level significantly lower than 80 dB(A) up to 10 MW.

This integrated and patented system on all NEXTRON burners is definitely a good replacement of the traditional bulky sound proofing box.

BUILT-IN AND MODULAR SWITCH CABINET

All the NEXTRON burners feature integrated switch cabinet, the ISC System, with modular concept for control devices and accessories:

- adjusting and safety control box;
 - EMC protected power circuit of fan motor;
 - display with keyboard in front of the control panel.
- The ISC System houses options and accessories, such as the power regulator and the frequency inverter Variatron, and customizes each burner according to the installation needs.

RANGE OVERVIEW



/ GAS RANGE
340 / 11200 kW



/ DUAL FUEL RANGE
250 / 10620 kW



/ LIGHT OIL RANGE
360 / 10620 kW



/ LOW NO_x / ULTRA LOW NO_x
up to 10200 kW

MAIN TECHNICAL FEATURES

- Two stage progressive/modulating forced draught burner
- Fuels:
 - natural gas, Hi = 6,99 ... 11,39 kWh/Nm³
 - LPG, Hi = 25,89 kWh/Nm³
 - light oil, viscosity 6 mm²/s at 20°C, Hi = 11,86 kWh/kg
- Combustion technology:
 - Low NOx class 4 (≤60 mg/kWh), class 3 (≤80 mg/kWh) and class 2 (≤120 mg/kWh) in gas operation, according to EN676
 - Low NOx class 3 (≤120 mg/kWh) and class 2 (≤185 mg/kWh) in light oil operation, according to EN267
- Integrated switch cabinet (ISC System) with modular concept complete for an easy installation with:
 - BT300 control box (MDE2 System and display);
 - fan motor direct start-up;
 - enumerated connection terminals;
 - power regulator (option);
 - speed controller Variatron (option);
 - O₂ control (option);
 - Bus interface (option)
- Innovative design allowing easy access to burner components for fast start-up and reduced maintenance time and space
- Three flame tube lengths available
- Secured burner head adjustments during maintenance (RTC System)
- Unique air intake channel design (patented) to reduce acoustic levels (Low Noise System)
- Closing of the air damper on burner shut-down
- Multiple gas train matching according to the inlet gas pressure
- Gas train factory assembled and tested for tightness and electrical security
- Products are in compliance with EN676 and EN267 European standards and with the following directives:
 - 2014/35/UE Low Voltage Directive
 - 2014/30/UE EMC Directive
 - 2016/426/UE Gas Appliances Regulation
 - 2006/42/EC Machinery Directive
 - 2011/65/EU RoHS2 Directive

PRODUCT LIST

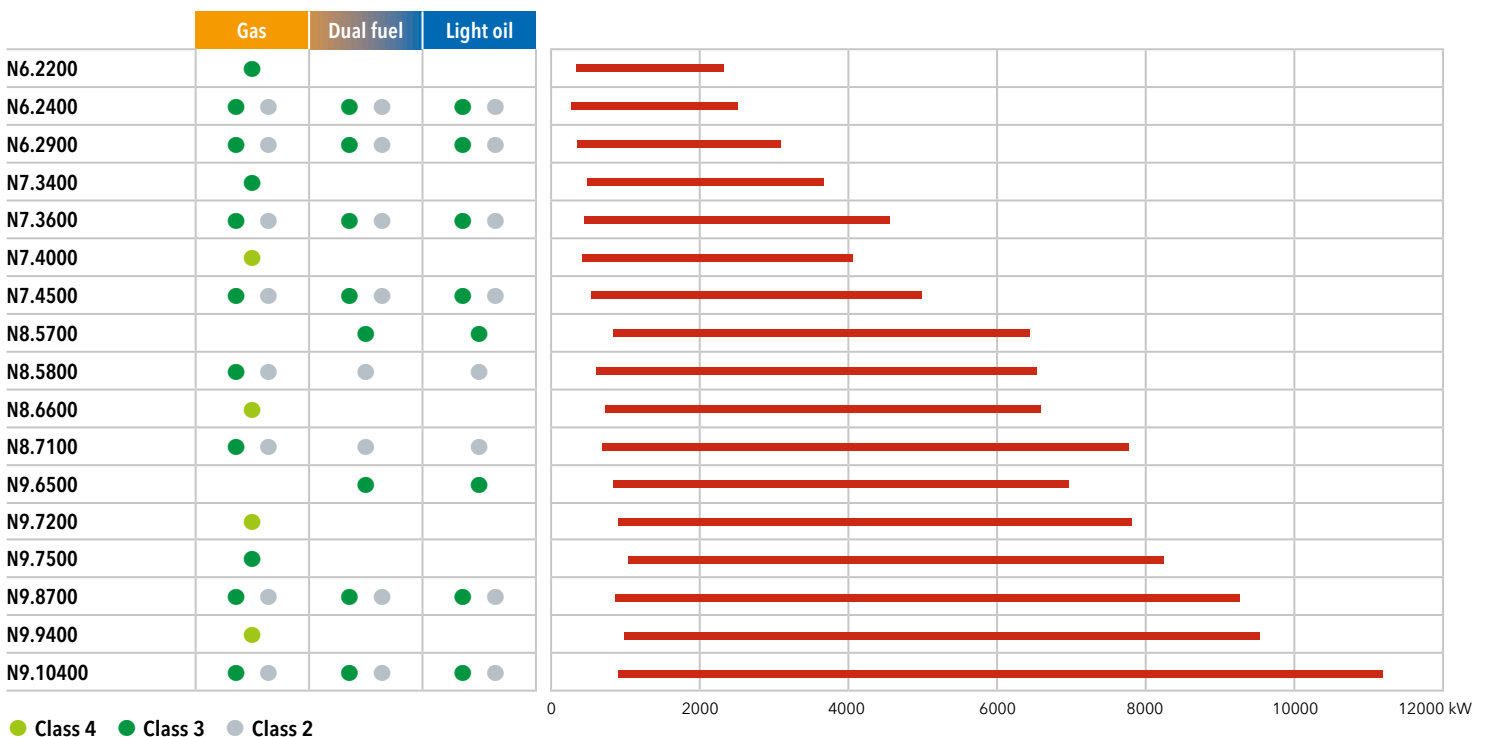

N7 G-EFX / N8 G-EFX

440 ... 6610 kW

Two stage progressive/modulating electronic



- **Fuels:** natural gas, Hi = 6,99 ... 11,39 kWh/Nm³; LPG, Hi = 25,89 kWh/Nm³
- **Emission class:** Low NOx class 4 (≤60 mg/kWh) according to EN676
- **Protection level:** IP 41

TECHNICAL DATA

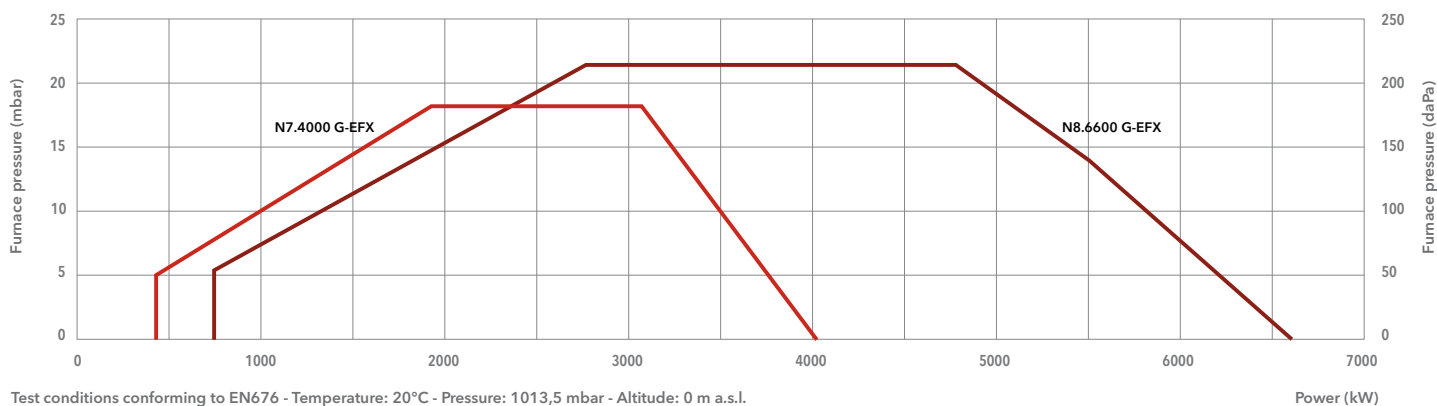

Test conditions conforming to EN676 - Temperature: 20°C - Pressure: 1013,5 mbar - Altitude: 0 m a.s.l.

	N7.4000 G-EFX	N8.6600 G-EFX
Operating range	440 – 4040 kW	730 – 6610 kW
Gas pressure	100 – 500 mbar (100 – 360 mbar for d705)	135 – 500 mbar
Gas connection	DN65	DN100
Control box / flame detector	BT300 / KLC	BT300 / KLC
Auxiliary voltage	1NPE AC 230 V – 50 Hz TN-S	1NPE AC 230 V – 50 Hz TN-S
Power supply	3PE AC 400 V – 50 Hz	3PE AC 400 V – 50 Hz
Fan motor	50 Hz – 7,5 kW	50 Hz – 15 kW
Acoustic level	<78 dB(A)	<83,7 dB(A)
CE certificate	0085CLO215	0085CLO215
Burner codes (body + head)	KN	on request
	KM	on request
	KL	on request

GAS TRAINS

DUNGS

Models for N7	Code
GT-d705-2" (*)	3759628
GT-d701-65	3759625
GT-d702-80	3759626
GT-d703-100	3759627

Models for N8	Code
GT-d901-65	3759630
GT-d902-80	3759631
GT-d903-100	3759632

SIEMENS

Model for N7	Code
GT-s705-2"	3759284
GT-s701-65	3759280
GT-s702-80	3759281
GT-s703-100	3759282
GT-s704-125	3759283

Models for N8	Code
GT-s901-65	3759286
GT-s902-80	3759287
GT-s903-100	3759288
GT-s904-125	3759289

FILTERS

Model	Code
FG-Rp2"	3757200
FG-DN65	3757198
FG-DN80	3757201
FG-DN100	3757195
FG-DN125	3757209

*: integrated filter

i Pressure drops graphs: see following pages
Dimensions of gas trains and gas filters: see page 308



DIMENSIONS (mm)

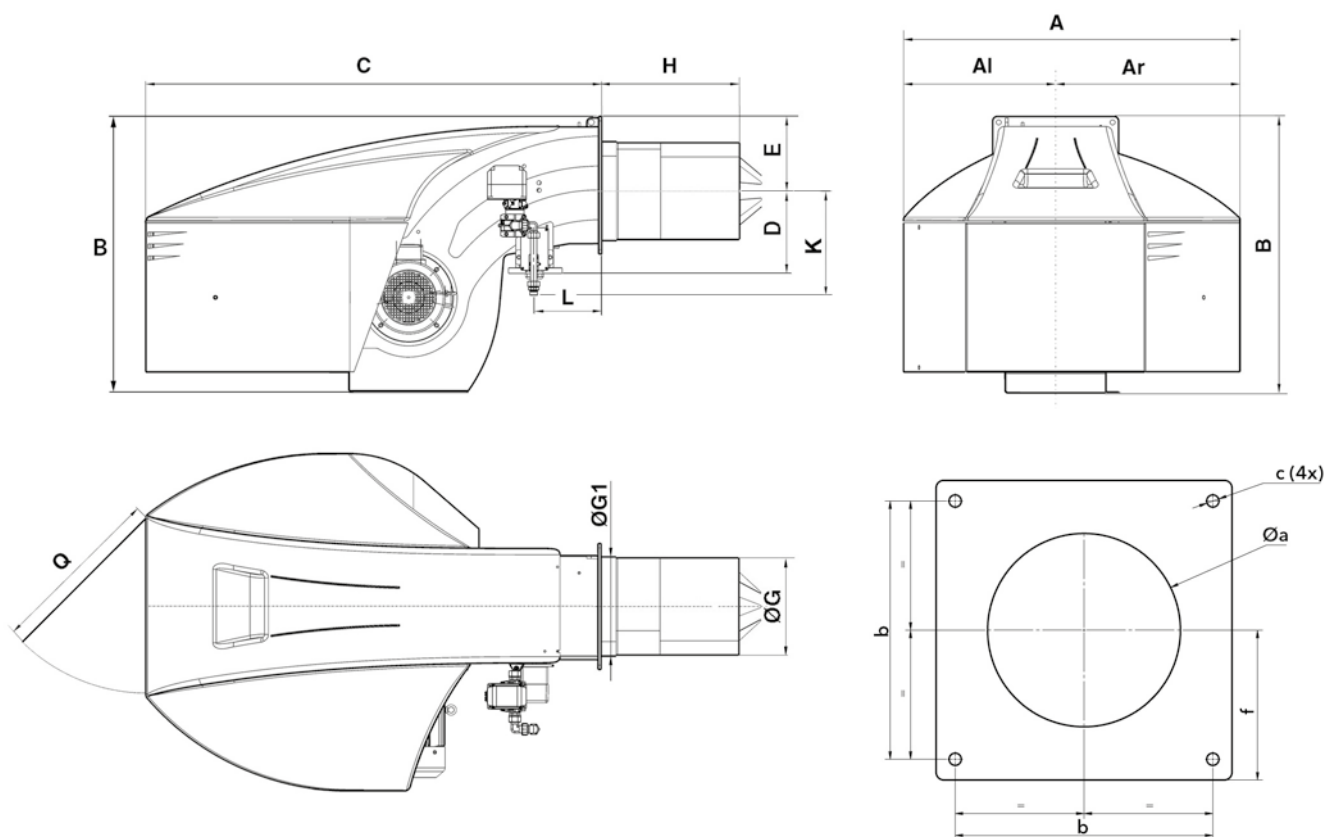

Model	A	AI	Ar	B	C	D	E	ØG	ØG1	H			K	L	Q	Øa	b	c	f
										KN	KM	KL							
N7.4000 G-EFX	1128	510	618	961	1529	276	255	325	338	420	550	680	320	233	600	360-400	400	M16	235
N8.6600 G-EFX	1414	669	745	1231	1930	391	293	369	376	575	725	875	377*/366**	230	800	380-410	505	M20	293

*: applies to gas connectors DN100/65 and DN100/85

** : applies to gas connectors DN100/100 and DN100/125

PACKAGING

The burner is delivered on a pallet with:

- burner body with mounted combustion head
- gas train and filter
- boiler fixing accessories
- technical documentation

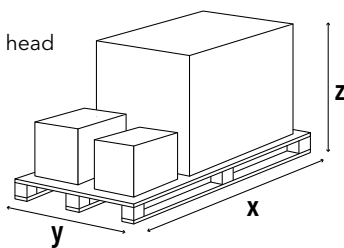

Model	Dimensions (mm)			Gross weight (kg)
	X	Y	Z	
N7.4000 G-EFX	2300	1600	1573	450
N8.6600 G-EFX	2300	1600	1573	700

N6 G-EFX / N7 G-EFX

440 ... 6610 kW

Two stage progressive/modulating electronic

PRESSURE LOSS [BURNER HEAD + GAS TRAIN] (mbar)

N7.4000 G-EFX

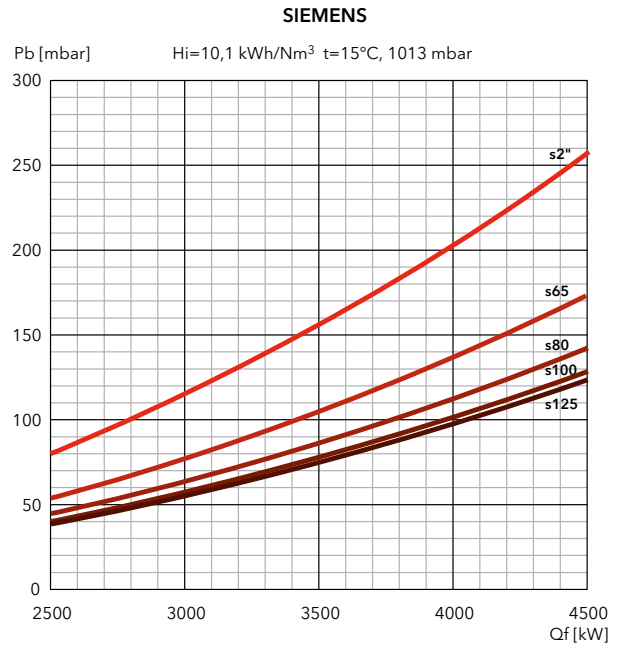
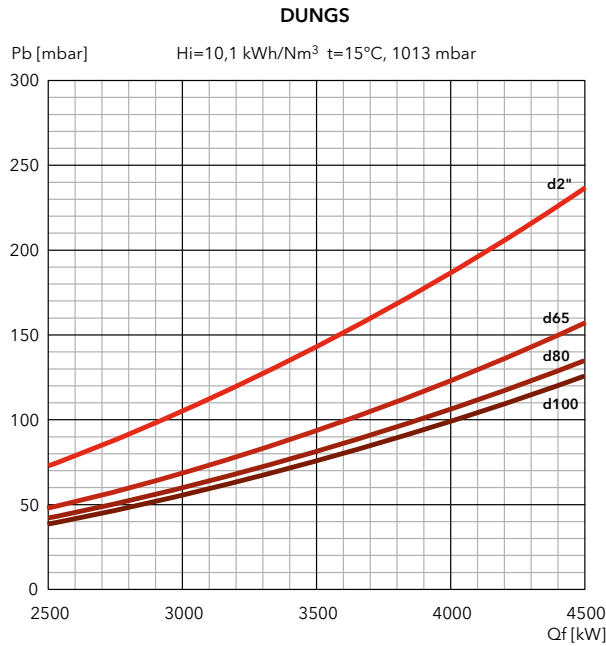

FILTERS

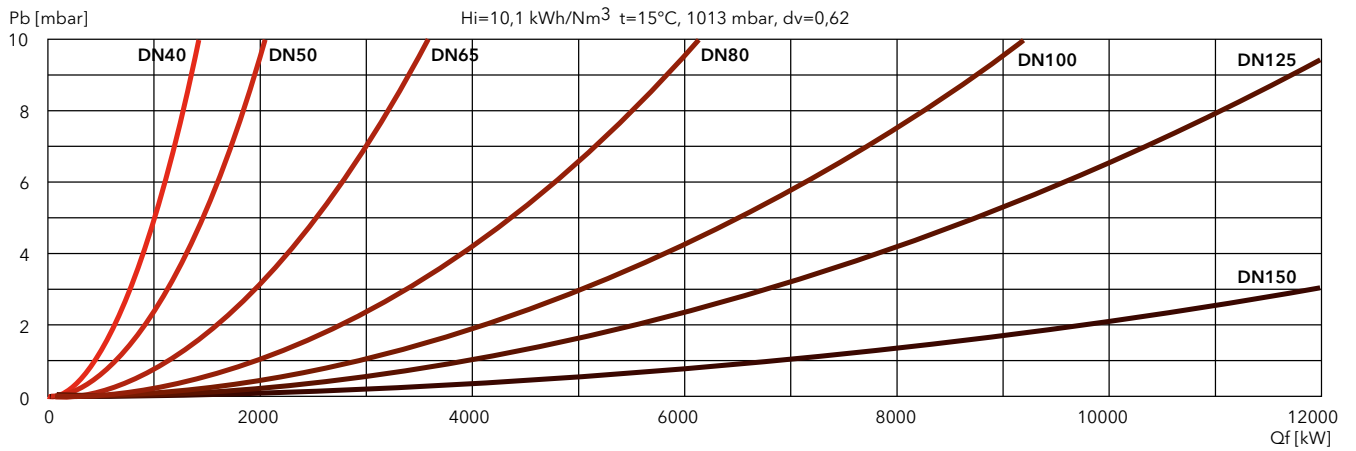



PRESSURE LOSS [BURNER HEAD + GAS TRAIN] (mbar)

N8.6600 G-EFX

DUNGS

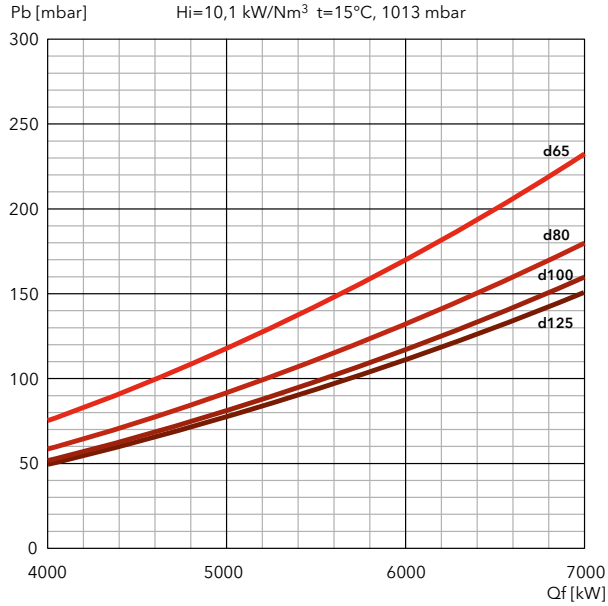

SIEMENS

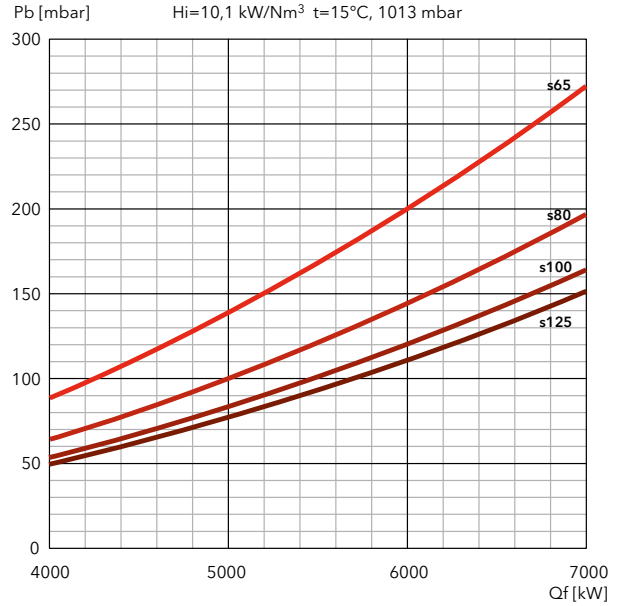

FILTERS

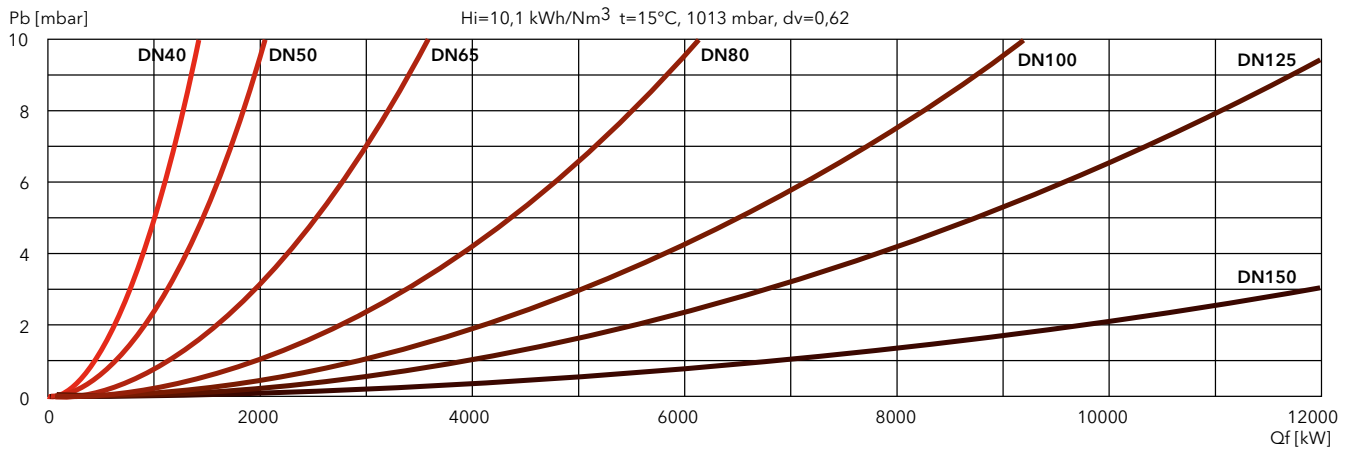

N9 G-EFX

890 ... 9940 kW

Two stage progressive/modulating electronic

NOx
<50
mg/kWh



- **Fuels:** natural gas, Hi = 6,99 ... 11,39 kWh/Nm³;
LPG, Hi = 25,89 kWh/Nm³
- **Emission class:** Low NOx class 4 (≤60 mg/kWh) according to EN676
- **Protection level:** IP 41

TECHNICAL DATA

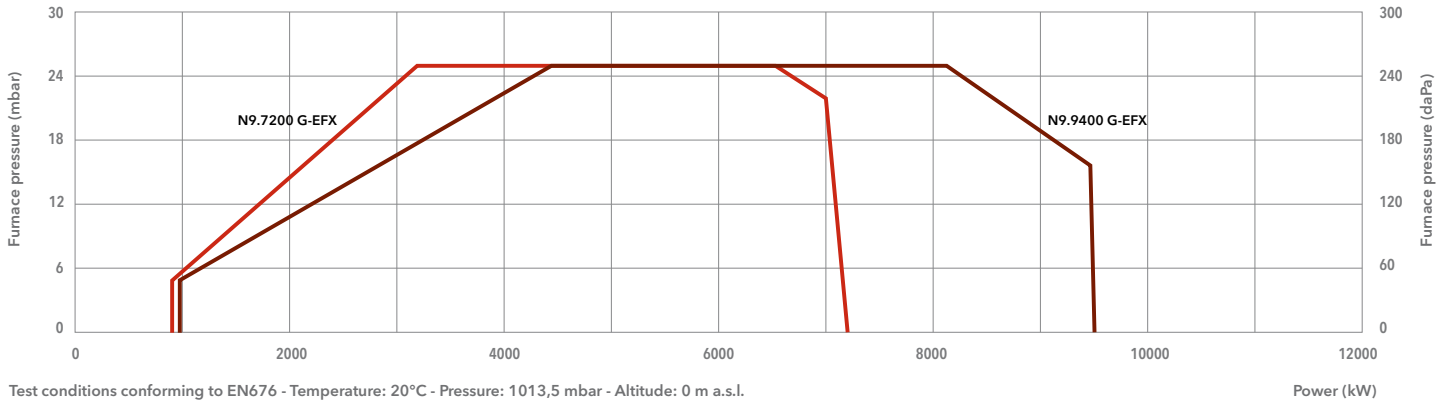

	N9.7200 G-EFX	N9.9400 G-EFX
Operating range	890 - 7200 kW	980 - 9440 kW
Gas pressure	150 - 500 mbar	175 - 500 mbar
Gas connection	DN100	DN100
Control box / flame detector	BT300 / KLC	BT300 / KLC
Auxiliary voltage	1NPE AC 230 V - 50 Hz TN-S	1NPE AC 230 V - 50 Hz TN-S
Power supply	3PE AC 400 V - 50 Hz	3PE AC 400 V - 50 Hz
Fan motor	50 Hz - 22 kW	50 Hz - 22 kW
Acoustic level	<79,5 dB(A)	<82,3 dB(A)
CE certificate	0085CL0215	0085CL0215
Burner codes (body + head)	KN	on request
	KM	on request
	KL	on request

GAS TRAINS

DUNGS

Model	Code
GT-d901-65	3759630
GT-d902-80	3759631
GT-d903-100	3759632

SIEMENS

Model	Code
GT-s901-65	3759286
GT-s902-80	3759287
GT-s903-100	3759288
GT-s904-125	3759289

FILTERS

Model	Code
FG-DN65	3757198
FG-DN80	3757201
FG-DN100	3757195
FG-DN125	3757209

i Pressure drops graphs: see following pages
Dimensions of gas trains and gas filters: see page 309



DIMENSIONS (mm)

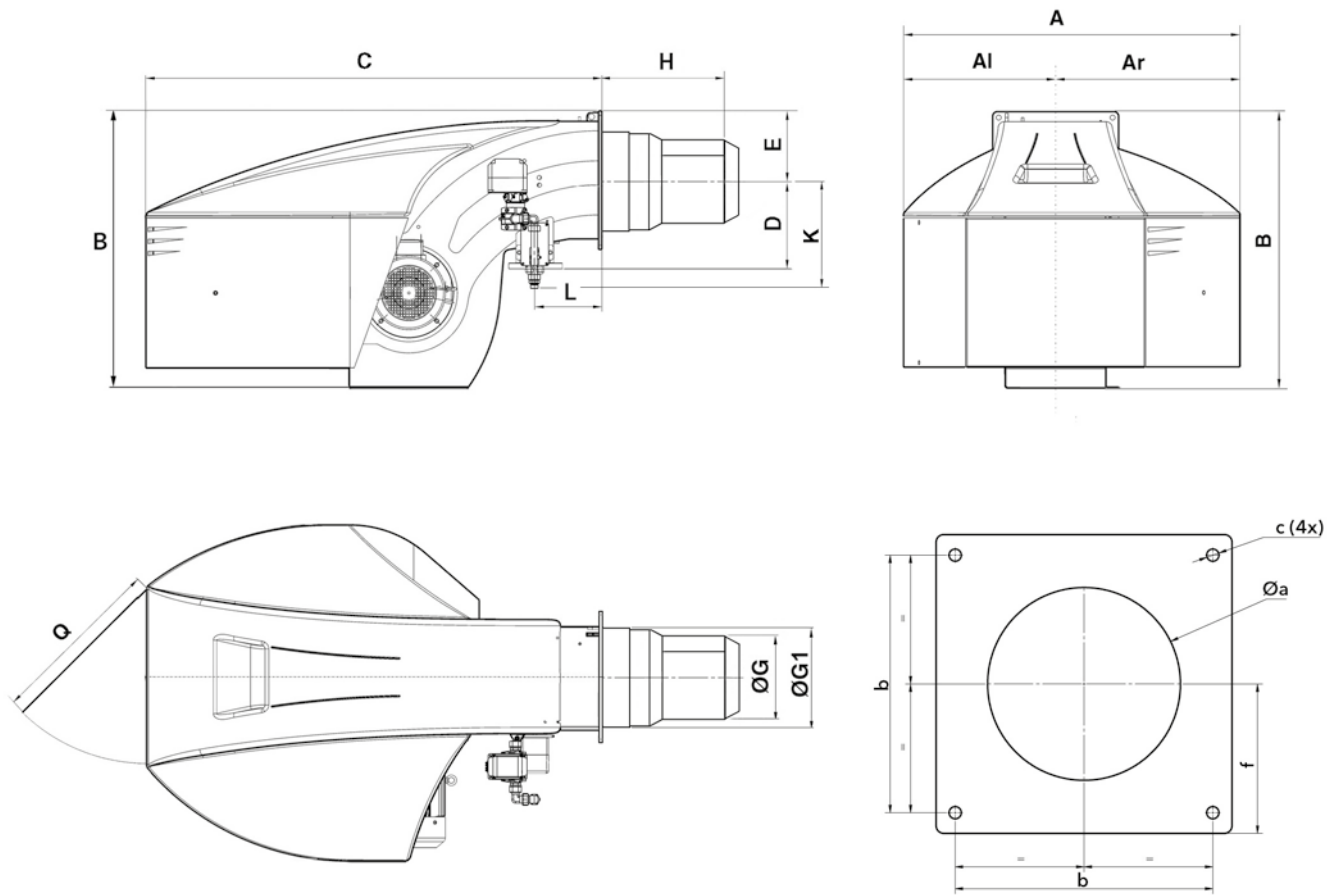

Model	A	Al	Ar	B	C	D	E	ØG	ØG1	H			L	Q	Øa	b	c	f
										KN	KM	KL						
N9.7200 G-EFX	1414	669	745	1291	1928	416	293	385	438,5	649	799	949	230	800	460-480	505	M20	293
N9.9400 G-EFX	1414	669	745	1291	1928	416	293	395	438,5	629	779	929	230	800	460-480	505	M20	293

PACKAGING

The burner is delivered on a pallet with:

- burner body with mounted combustion head
- gas train and filter
- boiler fixing accessories
- technical documentation

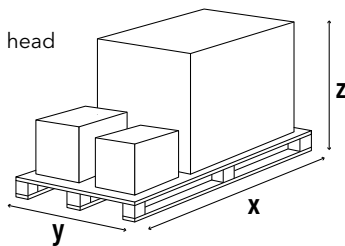

Model	Dimensions (mm)			Gross weight (kg)
	X	Y	Z	
N9.7200 G-EFX	2900	1600	1573	760
N9.9400 G-EFX	2900	1600	1573	760

N9 G-EFX

890 ... 9940 kW

Two stage progressive/modulating electronic

PRESSURE LOSS [BURNER HEAD + GAS TRAIN] (mbar)

N9.7200 G-EFX

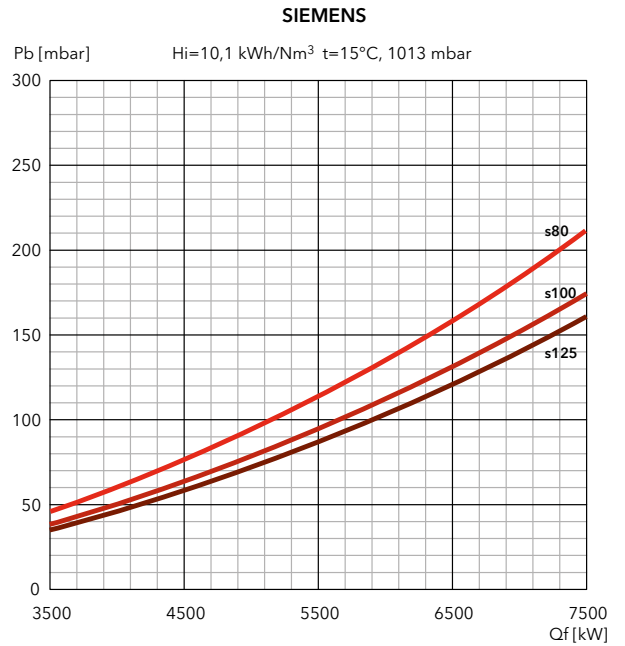
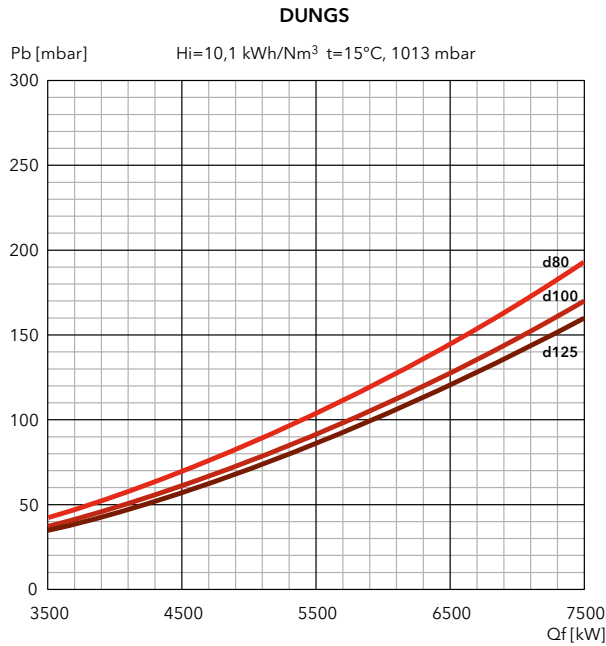

FILTERS

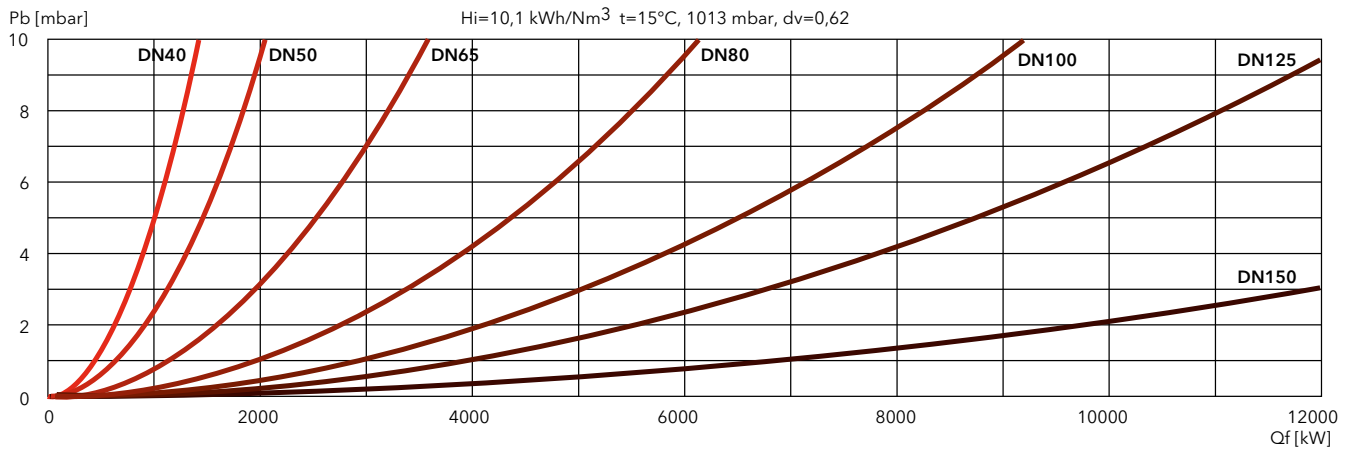



PRESSURE LOSS [BURNER HEAD + GAS TRAIN] (mbar)

N9.9400 G-EFX

DUNGS

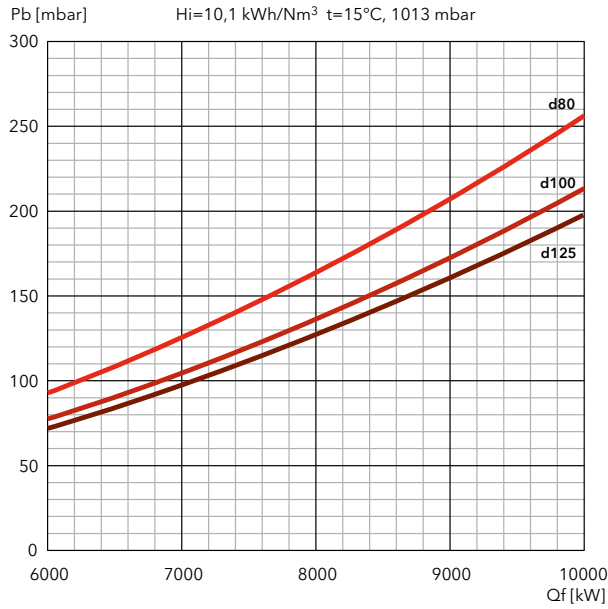

SIEMENS

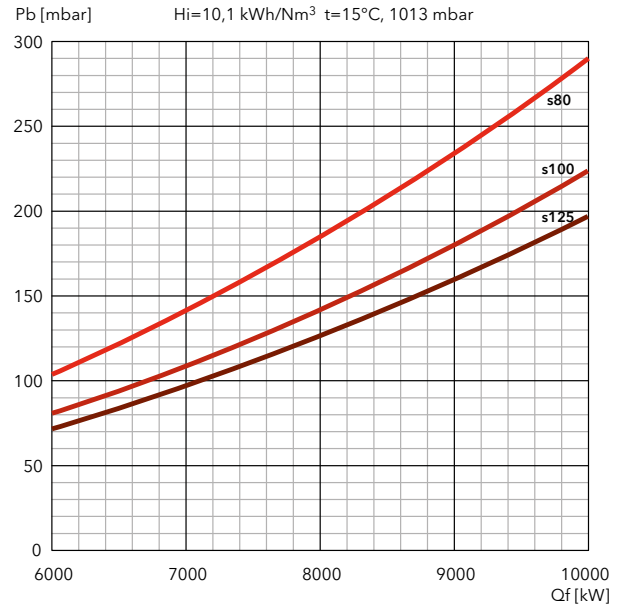

FILTERS

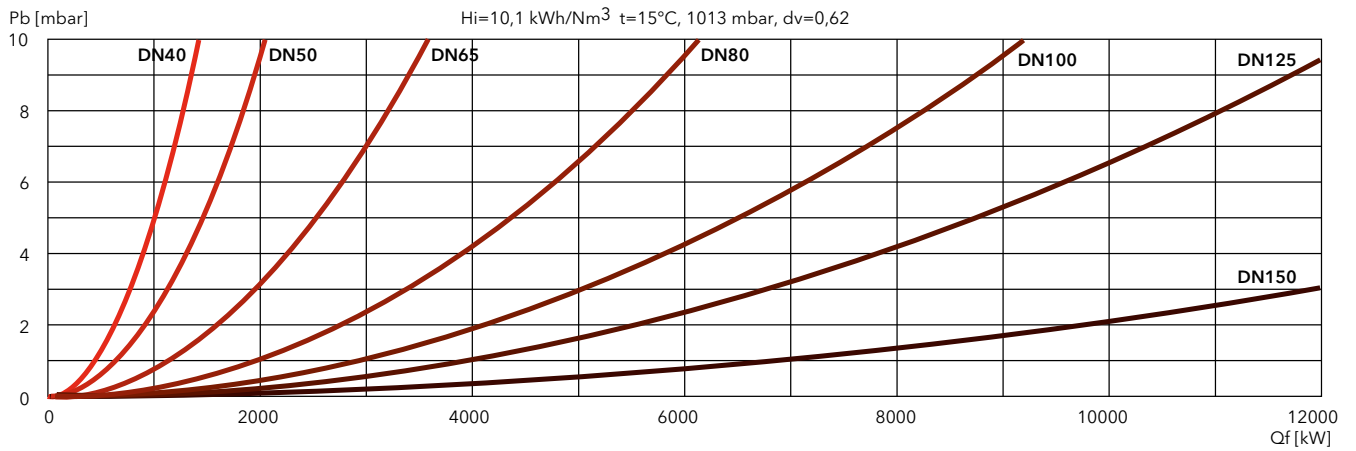

N6 G-EF3 / N7 G-EF3

340 ... 4200 kW

Two stage progressive/modulating electronic

- **Fuels:** natural gas, Hi = 6,99 ... 11,39 kWh/Nm³;
LPG, Hi = 25,89 kWh/Nm³
- **Emission class:** Low NOx class 3 (≤80 mg/kWh) according to EN676
- **Protection level:** IP 41



TECHNICAL DATA

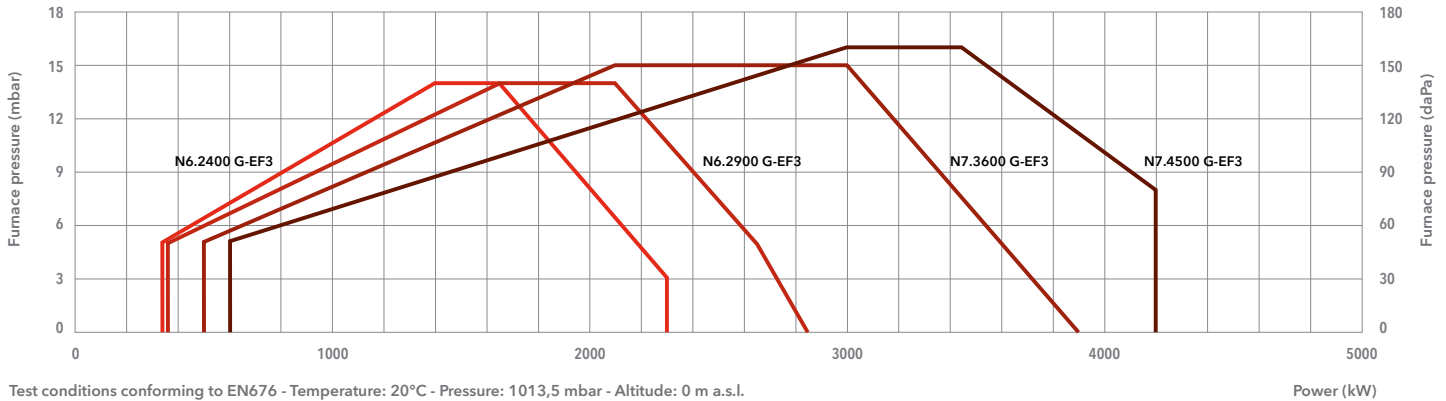

Test conditions conforming to EN676 - Temperature: 20°C - Pressure: 1013,5 mbar - Altitude: 0 m a.s.l.

	N6.2400 G-EF3	N6.2900 G-EF3	N7.3600 G-EF3	N7.4500 G-EF3
Operating range	340 – 2300 kW	360 – 2850 kW	500 – 3900 kW	600 – 4200 kW
Gas pressure	50 – 500 mbar (50 – 360 mbar for d452 and d453 gas train)		50 – 500 mbar (50 – 360 mbar for d452 and d453 gas train)	
Gas connection	DN65	DN65	DN65	DN65
Control box / flame detector	BT300 / QRA2	BT300 / QRA2	BT300 / QRA2	BT300 / QRA2
Auxiliary voltage	1NPE AC 230 V – 50 Hz TN-S	1NPE AC 230 V – 50 Hz TN-S	1NPE AC 230 V – 50 Hz TN-S	1NPE AC 230 V – 50 Hz TN-S
Power supply	3PE AC 400 V – 50 Hz	3PE AC 400 V – 50 Hz	3PE AC 400 V – 50 Hz	3PE AC 400 V – 50 Hz
Fan motor	50 Hz – 3 kW	50 Hz – 4 kW	50 Hz – 7,5 kW	50 Hz – 7,5 kW
Acoustic level	<70 dB(A)	<71 dB(A)	<74 dB(A)	<75 dB(A)
CE certificate	0085CL0215	0085CL0215	0085CL0215	0085CL0215
Complete burner codes	on request	on request	on request	on request

GAS TRAINS

DUNGS

Model	Code
GT-d452-1"1/2 (*)	3750510
GT-d453-2" (*)	3750511
GT-d454-65	3750512
GT-d455-80	3750513
GT-d456-100	3750514

*: integrated filter

SIEMENS

Model	Code
GT-s451-1"1/2	3750525
GT-s452-2"	3750526
GT-s453-65	3750527
GT-s454-80	3750528
GT-s455-100	3750529
GT-s456-125	3750530

FILTERS

Model	Code
FG-Rp1"1/2	3757199
FG-Rp2"	3757200
FG-DN65	3757198
FG-DN80	3757201
FG-DN100	3757195
FG-DN125	3757209

i Pressure drops graphs: see following pages
Dimensions of gas trains and gas filters: see page 310



DIMENSIONS (mm)

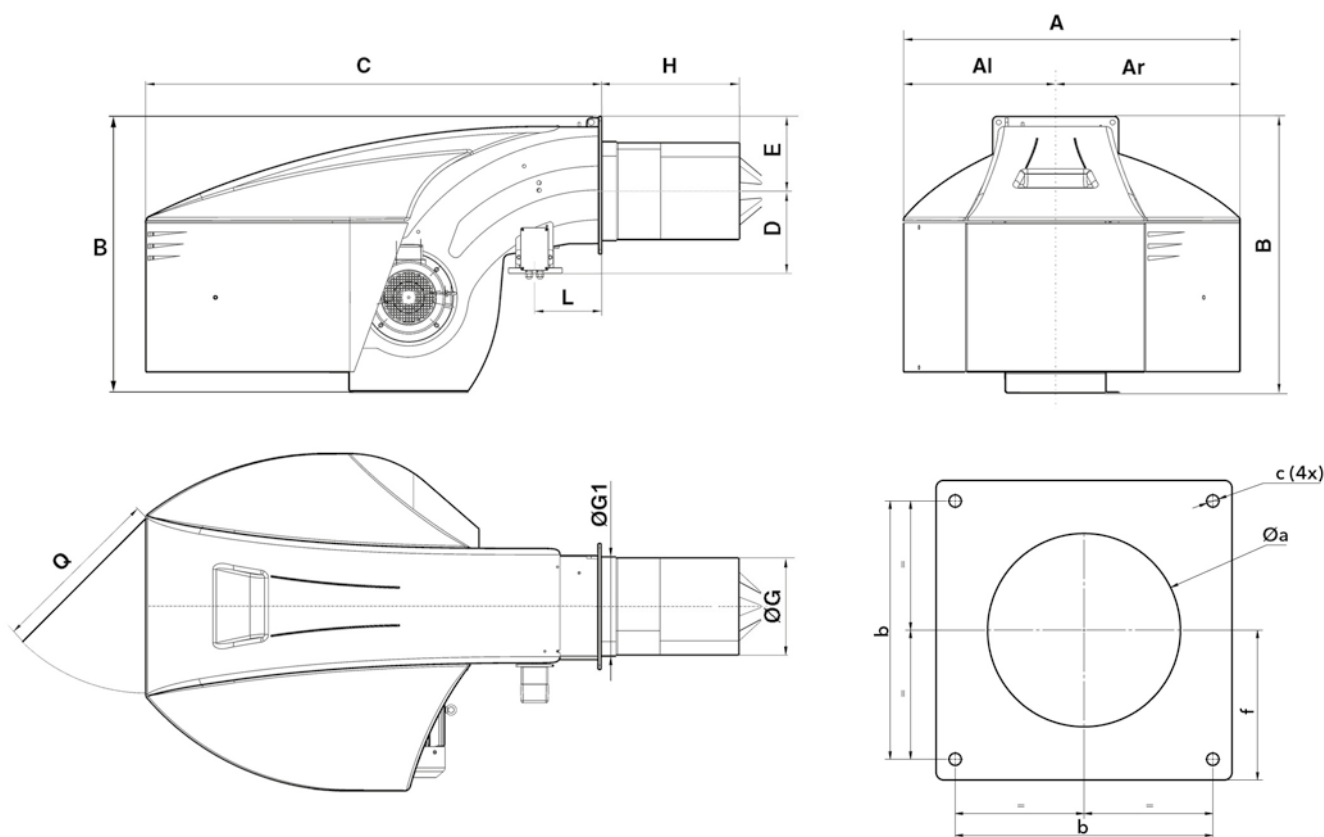

Model	A	Al	Ar	B	C	D	E	ØG	ØG1	H			L	Q	Øa	b	c	f
										KN	KM	KL						
N6... G-EF3	989	479	510	837	1361	245	225	263	270	400	520	640	215	600	330-340	340	M16	200
N7... G-EF3	1128	511	618	961	1529	276	255	325	332	420	550	680	225	600	380-400	400	M16	235

PACKAGING

The burner is delivered on a pallet with:

- burner body with mounted combustion head
- gas train and filter
- boiler fixing accessories
- technical documentation

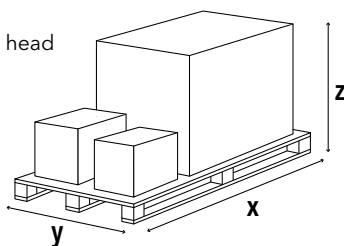

Model	Dimensions (mm)			Gross weight (kg)
	X	Y	Z	
N6.2400 G-EF3	2300	1500	1573	360
N6.2900 G-EF3	2300	1500	1573	360
N7.3600 G-EF3	2300	1500	1573	450
N7.4500 G-EF3	2300	1500	1573	450

N6 G-EF3 / N7 G-EF3

340 ... 4200 kW

Two stage progressive/modulating electronic

PRESSURE LOSS [BURNER HEAD + GAS TRAIN] (mbar)

N6.2400 G-EF3

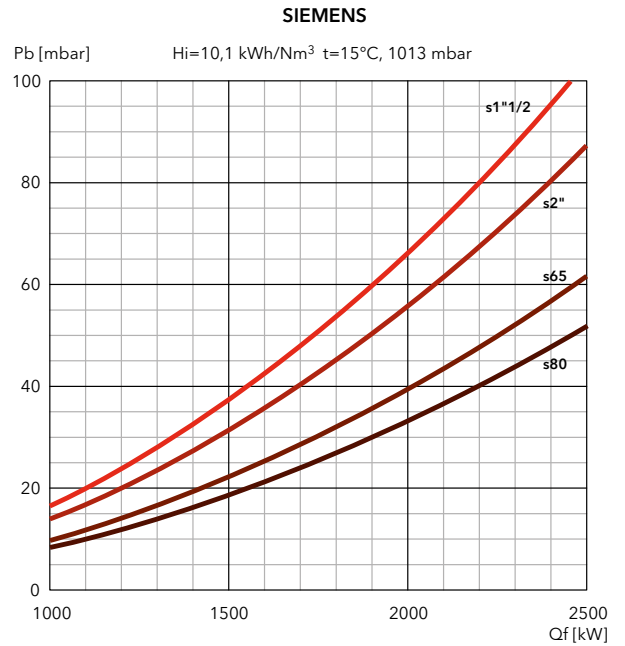
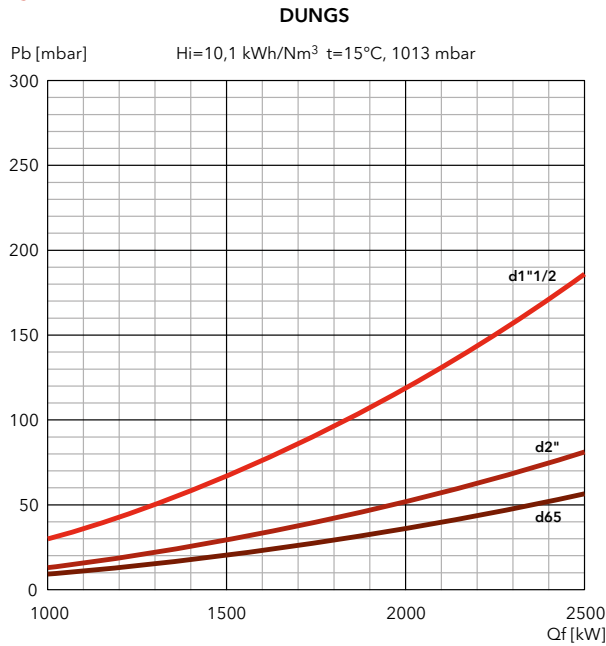

N6.2900 G-EF3

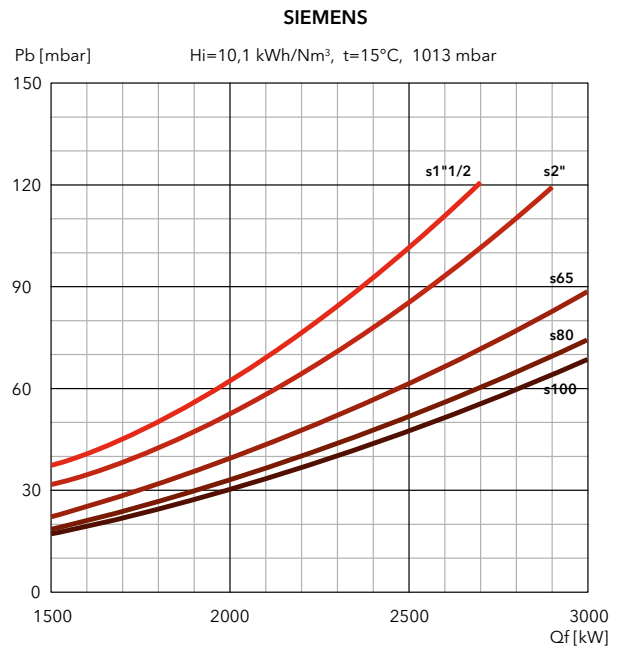
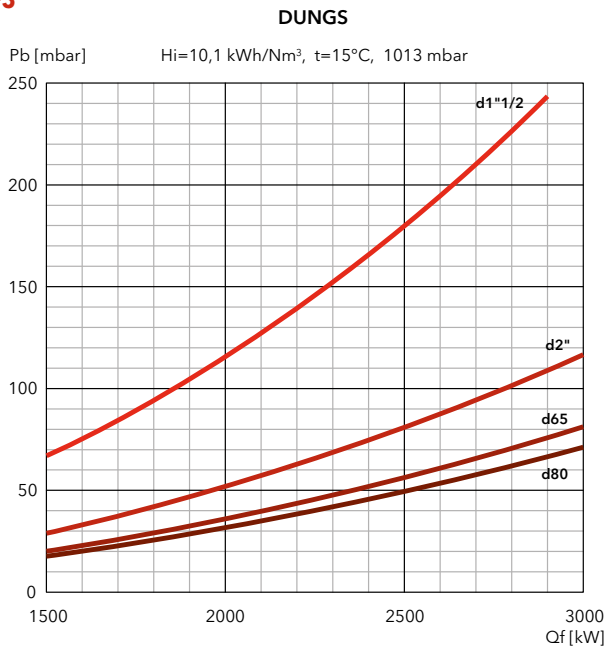

FILTERS

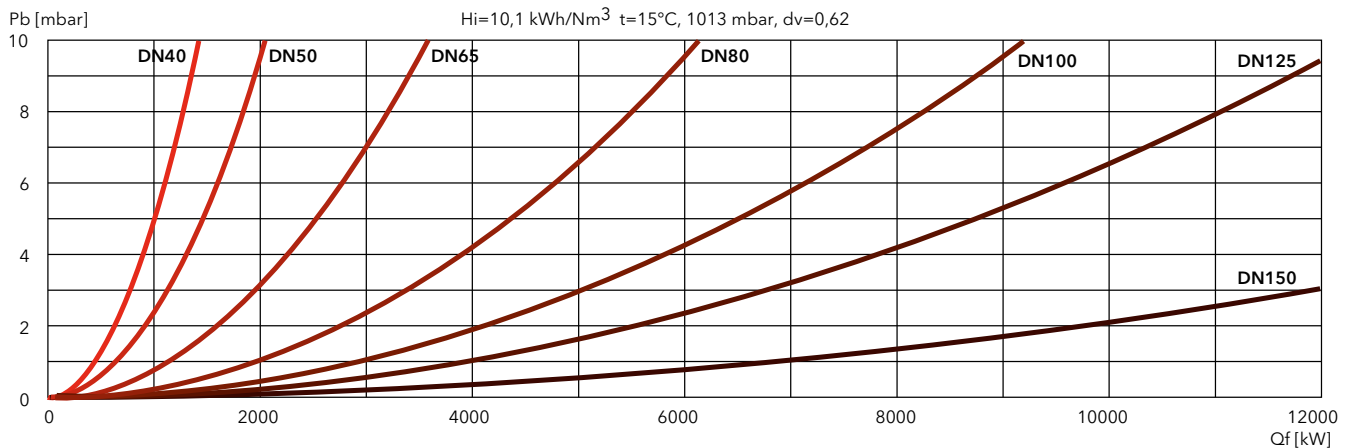



PRESSURE LOSS [BURNER HEAD + GAS TRAIN] (mbar)

N7.3600 G-EF3

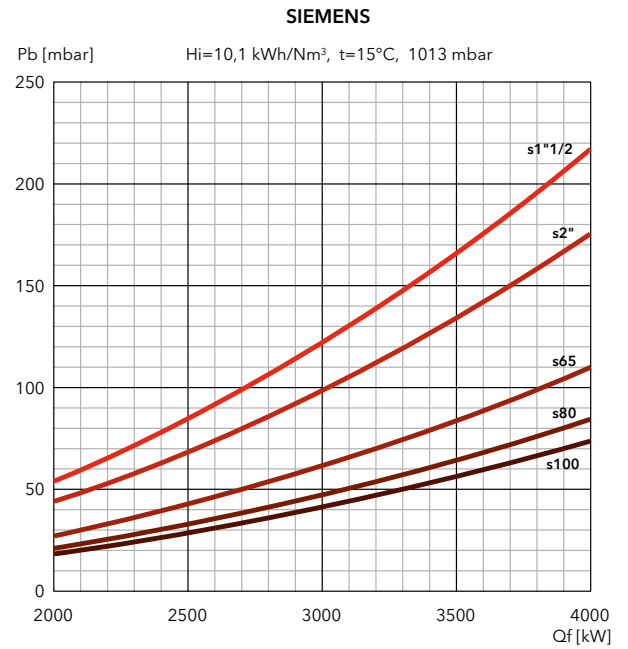
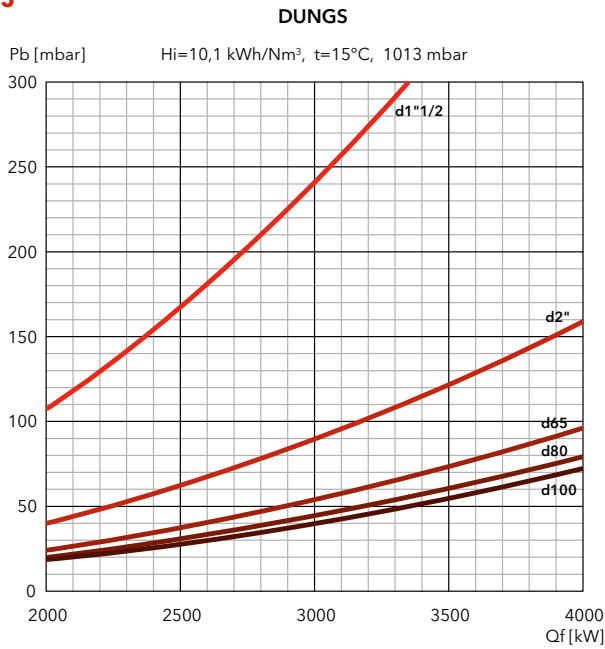

N7.4500 G-EF3

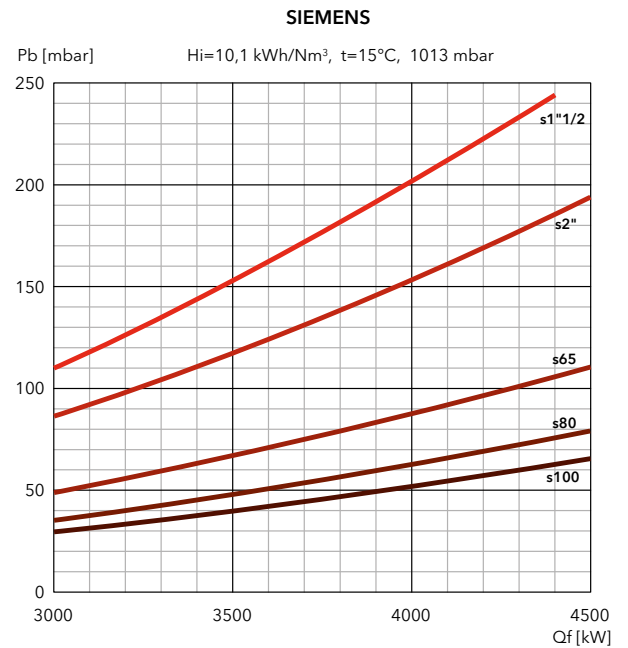
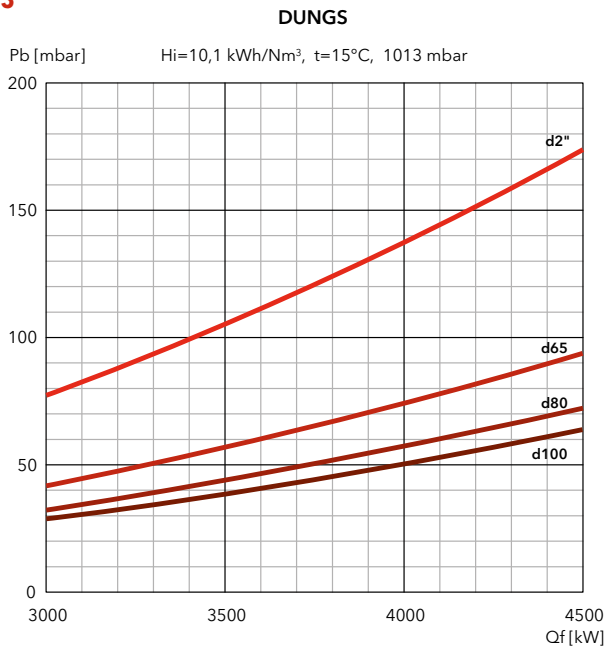

FILTERS

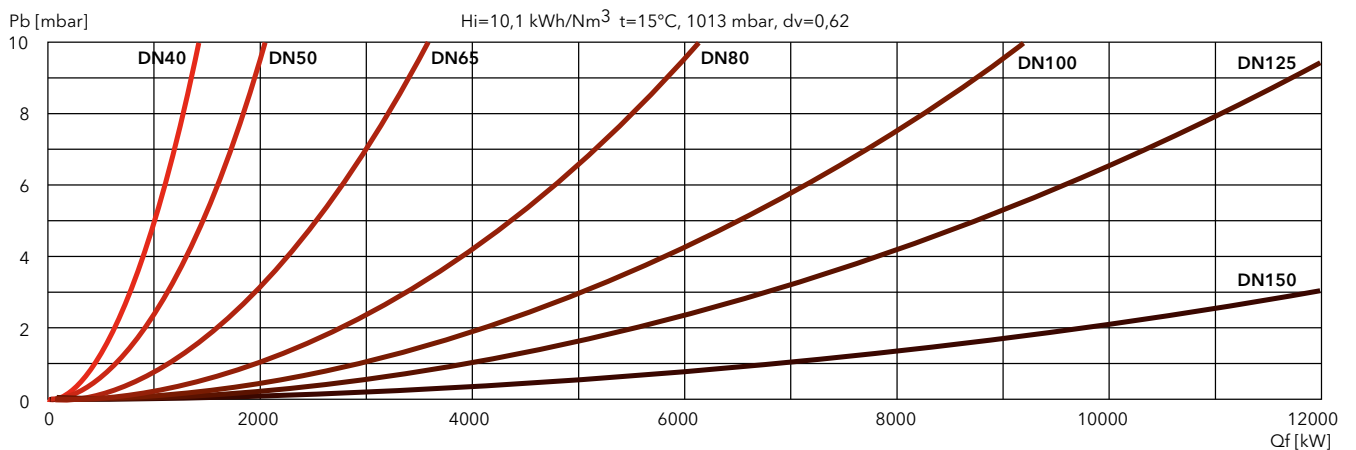

N8 G-EU3 / N9 G-EU3

640 ... 10200 kW

Two stage progressive/modulating electronic



- **Fuels:** natural gas, Hi = 6,99 ... 11,39 kWh/Nm³;
LPG, Hi = 25,89 kWh/Nm³
- **Emission class:** Low NOx class 3 (≤80 mg/kWh) according to EN676
- **Protection level:** IP 41

TECHNICAL DATA

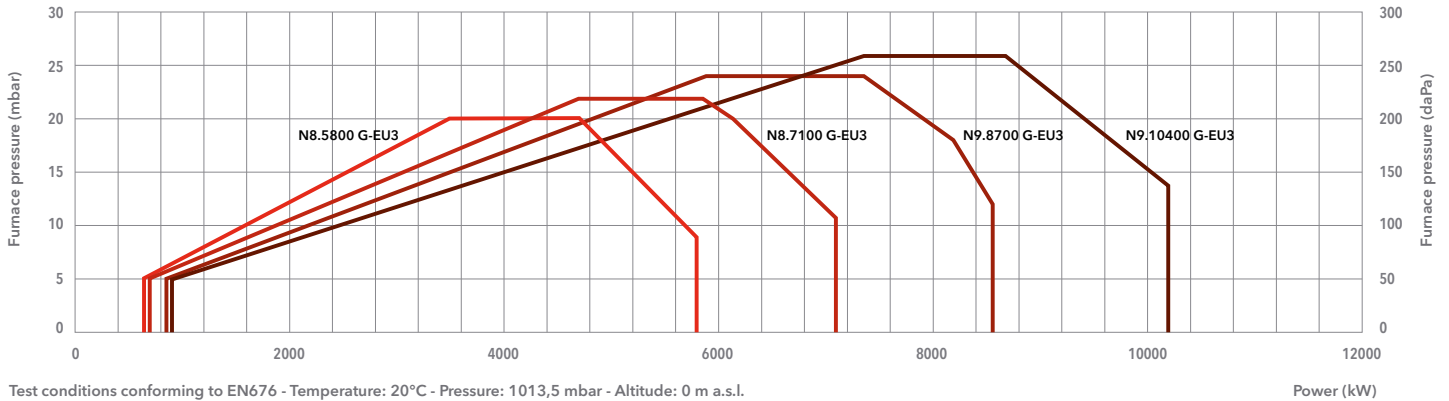

Test conditions conforming to EN676 - Temperature: 20°C - Pressure: 1013,5 mbar - Altitude: 0 m a.s.l.

	N8.5800 G-EU3	N8.7100 G-EU3	N9.8700 G-EU3	N9.10400 G-EU3
Operating range	640 - 5800 kW	700 - 7100 kW	850 - 8530 kW	900 - 10200 kW
Gas pressure	70 - 500 mbar (70 - 360 mbar for d457 gas train)		80 - 500 mbar (80 - 360 mbar for d457 gas train)	
Gas connection	DN100	DN100	DN100	DN100
Control box / flame detector	BT300 / Ionisation	BT300 / Ionisation	BT300 / Ionisation	BT300 / Ionisation
Auxiliary voltage	1NPE AC 230 V - 50 Hz TN-S	1NPE AC 230 V - 50 Hz TN-S	1NPE AC 230 V - 50 Hz TN-S	1NPE AC 230 V - 50 Hz TN-S
Power supply	3PE AC 400 V - 50 Hz	3PE AC 400 V - 50 Hz	3PE AC 400 V - 50 Hz	3PE AC 400 V - 50 Hz
Fan motor	50 Hz - 11 kW	50 Hz - 15 kW	50 Hz - 18,5 kW	50 Hz - 22 kW
Acoustic level	<78 dB(A)	<78 dB(A)	<80 dB(A)	<81 dB(A)
CE certificate	0085CL0215	0085CL0215	0085CL0215	0085CL0215
Complete burner codes	on request	on request	on request	on request

GAS TRAINS

DUNGS

Model	Code
GT-d457-2" (*)	3750515
GT-d458-65	3750516
GT-d459-80	3750517
GT-d460-100	3750518

SIEMENS

Model	Code
GT-s457-2"	3750537
GT-s458-65	3750538
GT-s459-80	3750539
GT-s460-100	3750540
GT-s461-125	3750541

FILTERS

Model	Code
FG-Rp2"	3757200
FG-DN65	3757198
FG-DN80	3757201
FG-DN100	3757195
FG-DN125	3757209

*: integrated filter

i Pressure drops graphs: see following pages
Dimensions of gas trains and gas filters: see page 311



DIMENSIONS (mm)

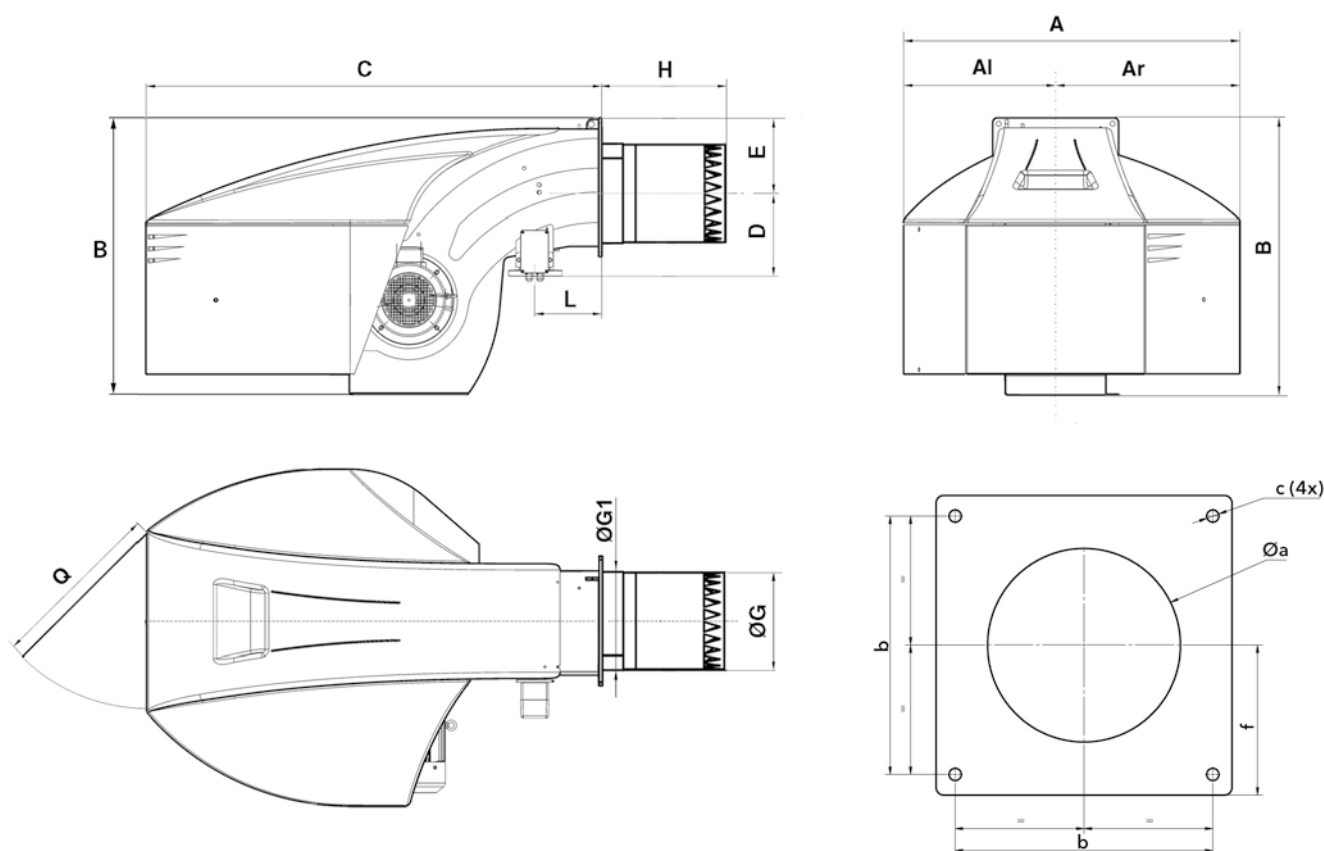

Model	A	Al	Ar	B	C	D	E	ØG	ØG1	H			L	Q	Øa	b	c	f
										KN	KM	KL						
N8... G-EU3	1414	669	745	1231	1930	344	293	369	377	500	640	780	230	800	390-410	505	M20	293
N9... G-EU3	1414	669	745	1291	1930	372	293	431,5	439,5	550	700	850	230	800	460-480	505	M20	293

PACKAGING

The burner is delivered on a pallet with:

- burner body with mounted combustion head
- gas train and filter
- boiler fixing accessories
- technical documentation

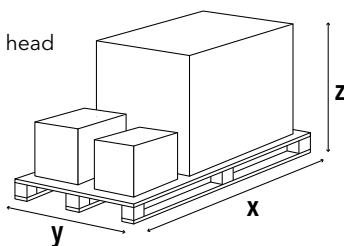

Model	Dimensions (mm)			Gross weight (kg)
	X	Y	Z	
N8.5800 G-EU3	2900	1600	1573	700
N8.7100 G-EU3	2900	1600	1573	700
N9.8700 G-EU3	2900	1600	1573	760
N9.10400 G-EU3	2900	1600	1573	760

N8 G-EU3 / N9 G-EU3

640 ... 10200 kW

Two stage progressive/modulating electronic

PRESSURE LOSS [BURNER HEAD + GAS TRAIN] (mbar)

N8.5800 G-EU3

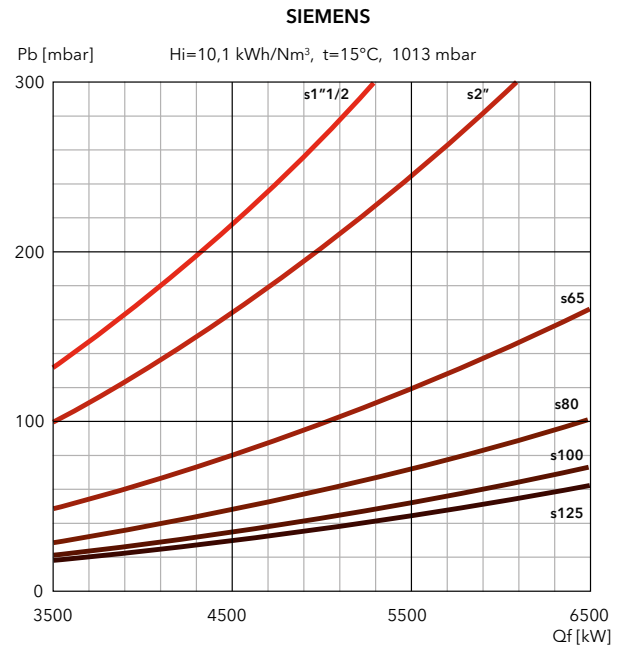
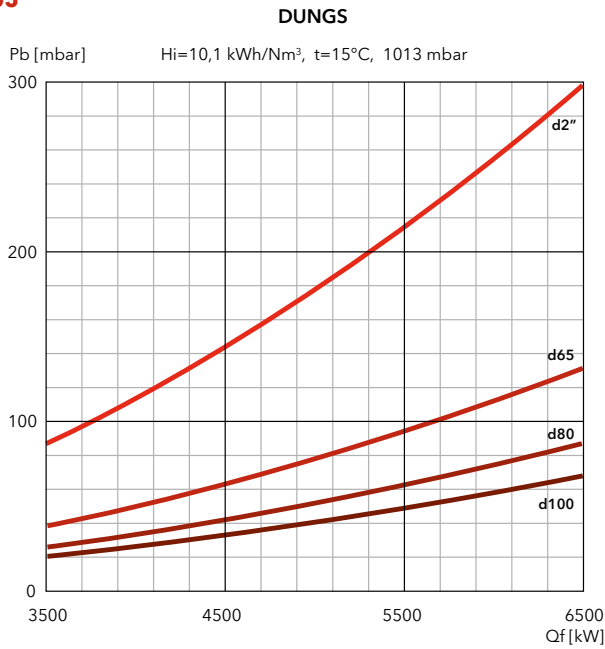

N8.7100 G-EU3

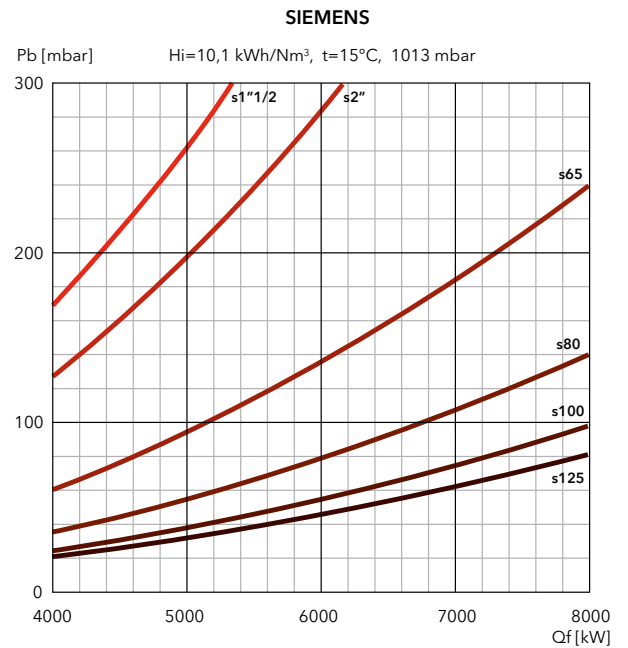
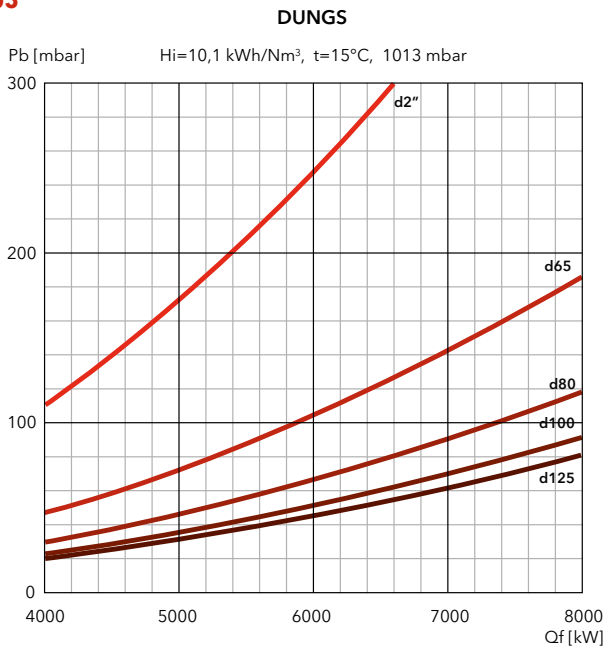

FILTERS

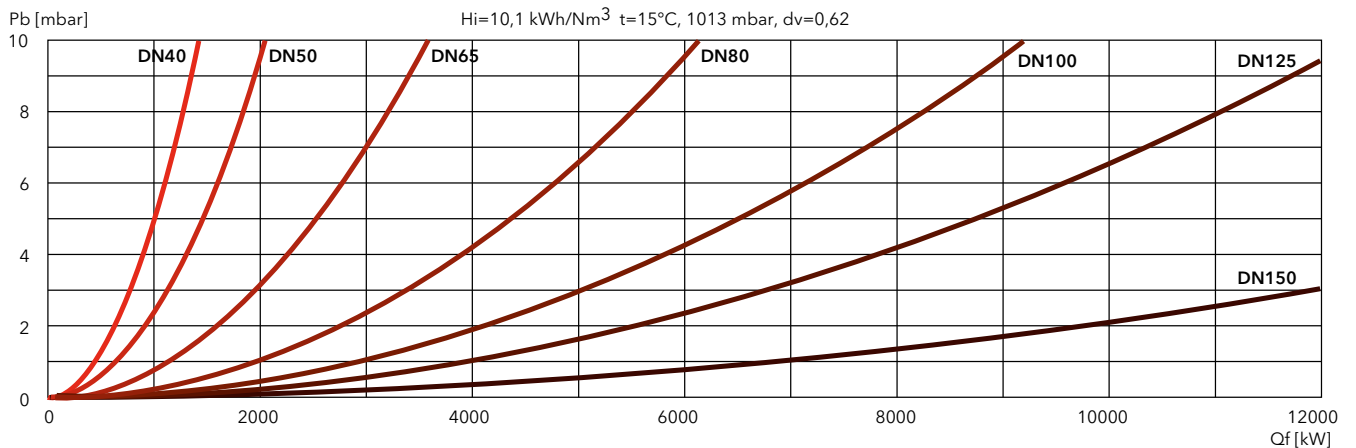



PRESSURE LOSS [BURNER HEAD + GAS TRAIN] (mbar)

N9.8700 G-EU3

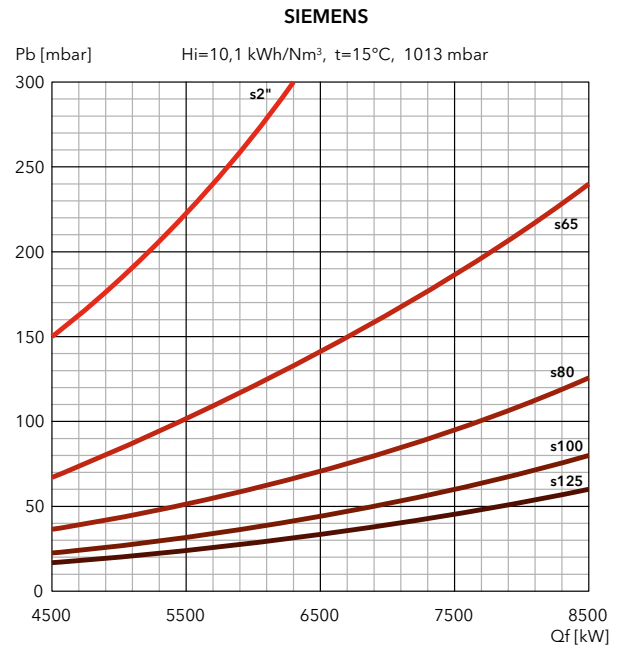
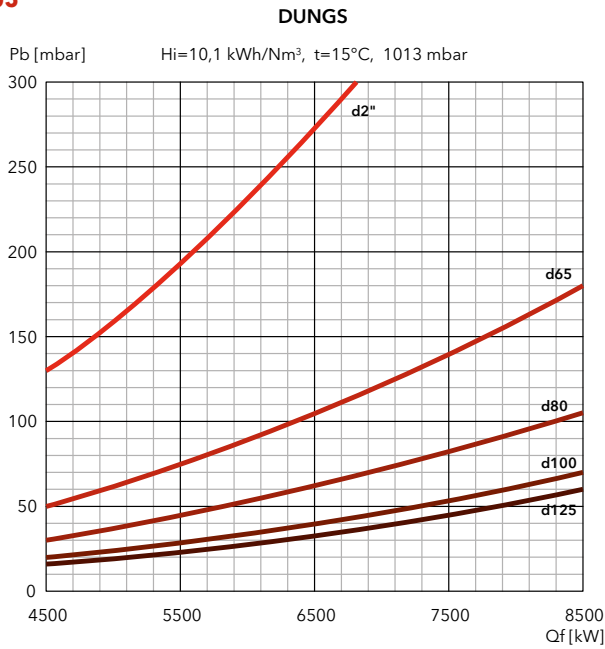

N9.10400 G-EU3

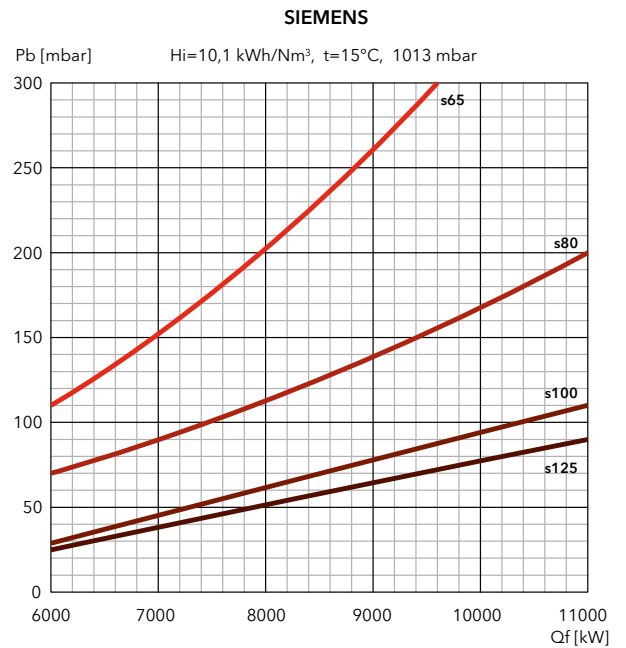
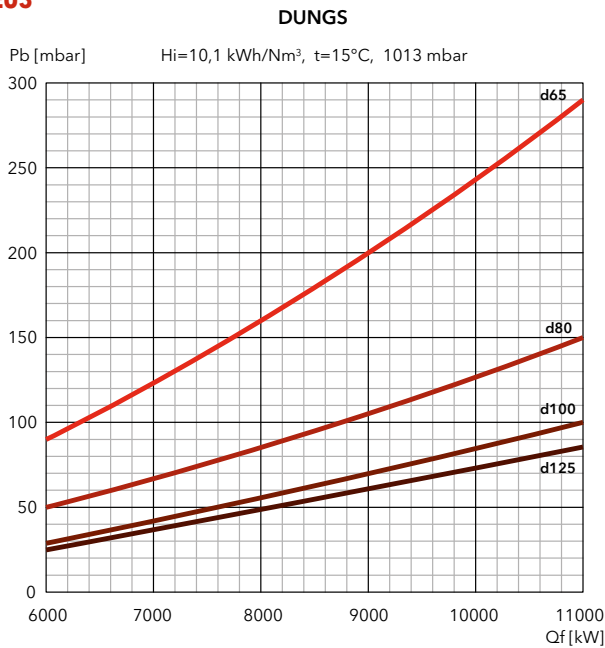

FILTERS

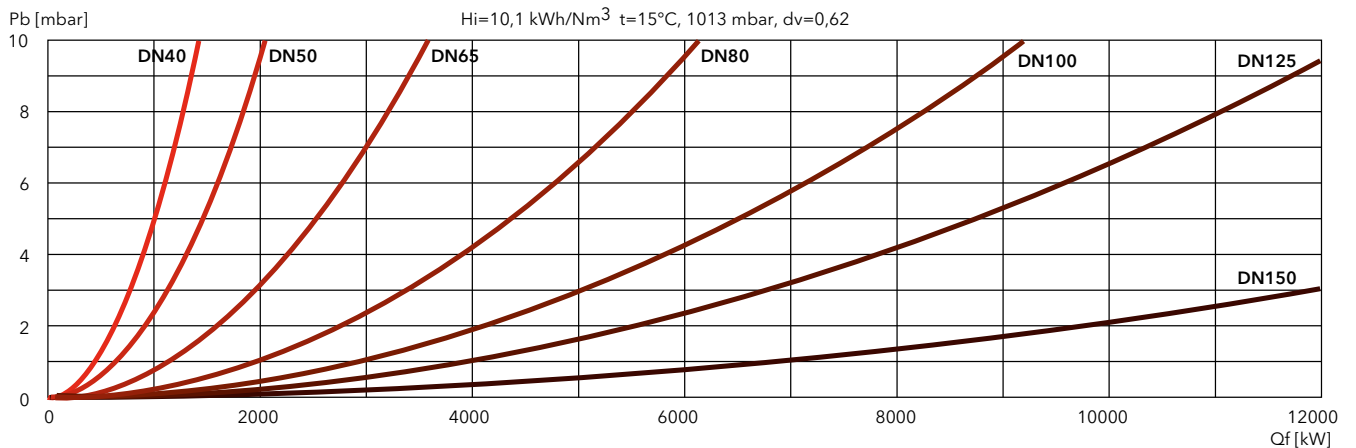

N6 G-EU2N / N7 G-EU2N

350 ... 3700 kW

Two stage progressive/modulating electronic

- **Fuels:** natural gas, Hi = 6,99 ... 11,39 kWh/Nm³;
LPG, Hi = 25,89 kWh/Nm³
- **Emission class:** Low NOx class 3 (≤80 mg/kWh) according to EN676
- **Protection level:** IP 41



TECHNICAL DATA

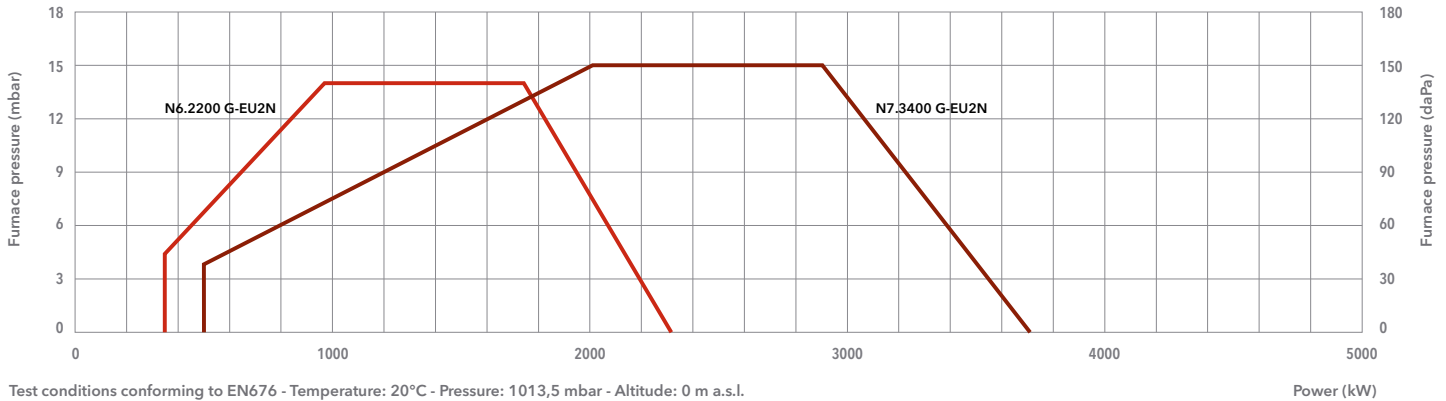

Test conditions conforming to EN676 - Temperature: 20°C - Pressure: 1013,5 mbar - Altitude: 0 m a.s.l.

	N6.2200 G-EU2N	N7.3400 G-EU2N
Operating range	350 – 2300 kW	490 – 3700 kW
Gas pressure	75 – 500 mbar (75 – 360 mbar for d452 and d453 gas train)	80 – 500 mbar (80 – 360 mbar for d452 and d453 gas train)
Gas connection	DN65	DN65
Control box / flame detector	BT300 / QRA2	BT300 / QRA2
Auxiliary voltage	1NPE AC 230 V – 50 Hz TN-S	1NPE AC 230 V – 50 Hz TN-S
Power supply	3PE AC 400 V – 50 Hz	3PE AC 400 V – 50 Hz
Fan motor	50 Hz – 4 kW	50 Hz – 7,5 kW
Acoustic level	<71 dB(A)	<76 dB(A)
CE certificate	0085CL0215	0085CL0215
Complete burner codes	on request	on request

GAS TRAINS

DUNGS

Model	Code
GT-d452-1"1/2 (*)	3750510
GT-d453-2" (*)	3750511
GT-d454-65	3750512
GT-d455-80	3750513
GT-d456-100	3750514

SIEMENS

Model	Code
GT-s451-1"1/2	3750525
GT-s452-2"	3750526
GT-s453-65	3750527
GT-s454-80	3750528
GT-s455-100	3750529

FILTERS

Model	Code
FG-Rp1"1/2	3757199
FG-Rp2"	3757200
FG-DN65	3757198
FG-DN80	3757201
FG-DN100	3757195

*: integrated filter

i **Pressure drops graphs:** see following pages
Dimensions of gas trains and gas filters: see page 310



DIMENSIONS (mm)

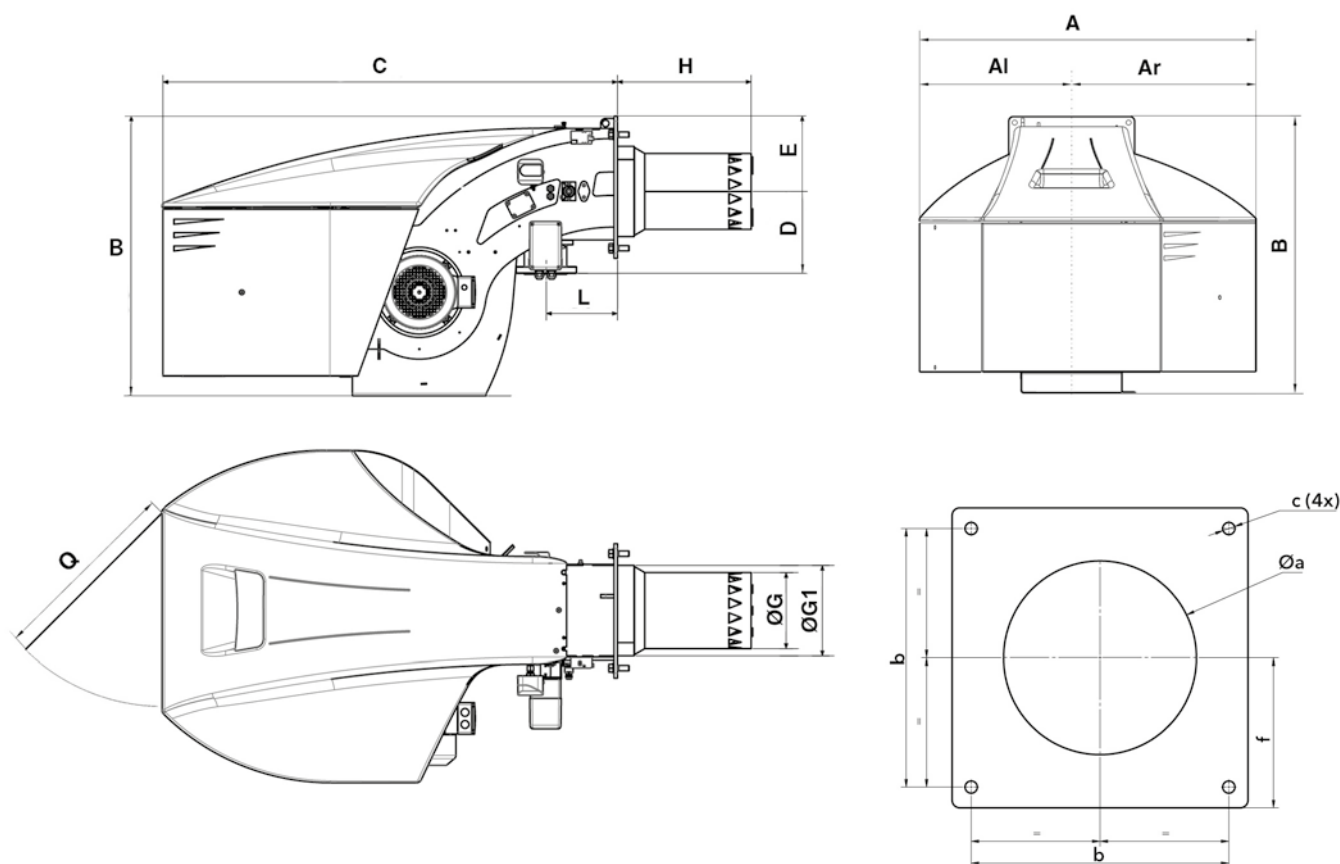

Model	A	Al	Ar	B	C	D	E	ØG	ØG1	H			L	Q	Øa	b	c	f
										KN	KM	KL						
N6.2200 G-EU2N	990	479	511	837	1358	245	225	227	270	400	520	640	215	600	300-340	340	M16	200
N7.3400 G-EU2N	1127	509	618	961	1527	276	255	263	332	420	550	680	225	600	370-400	400	M16	235

PACKAGING

The burner is delivered on a pallet with:

- burner body with mounted combustion head
- gas train and filter
- boiler fixing accessories
- technical documentation

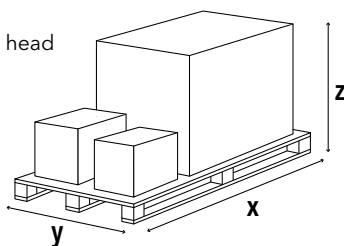

Model	Dimensions (mm)			Gross weight (kg)
	X	Y	Z	
N6.2200 G-EU2N	2300	1500	1573	360
N7.3400 G-EU2N	2300	1500	1573	450

N6 G-EU2N / N7 G-EU2N

350 ... 3700 kW

Two stage progressive/modulating electronic

PRESSURE LOSS [BURNER HEAD + GAS TRAIN] (mbar)

N6.2200 G-EU2N

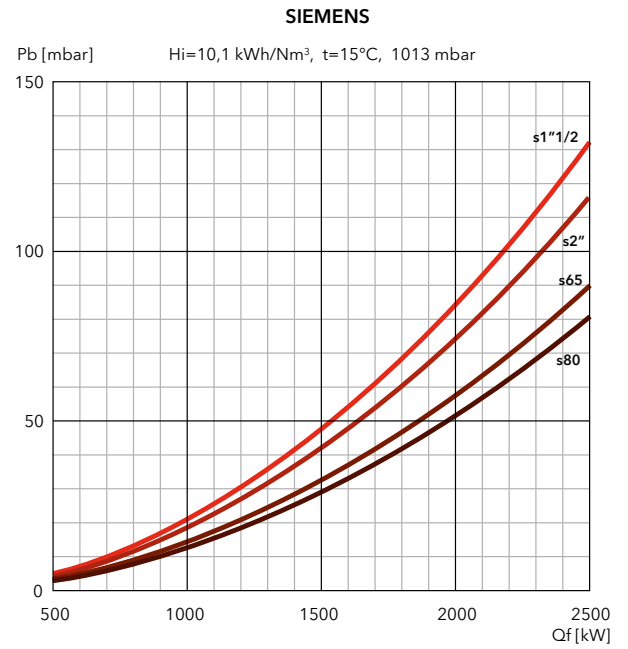
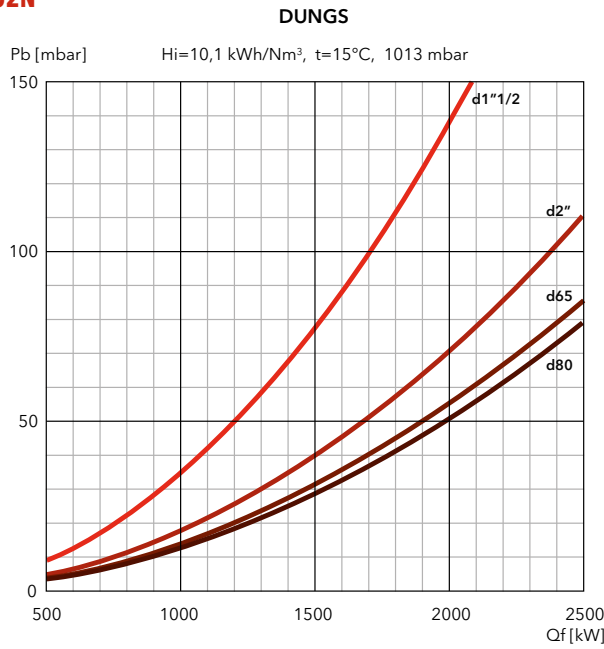

FILTERS

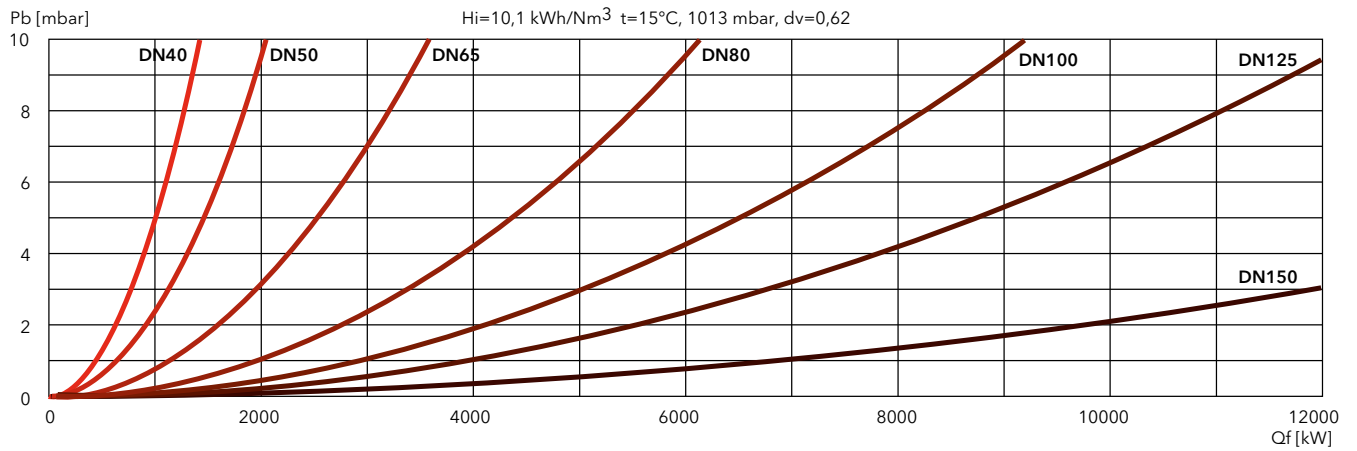



PRESSURE LOSS [BURNER HEAD + GAS TRAIN] (mbar)

N7.3400 G-EU2N

DUNGS

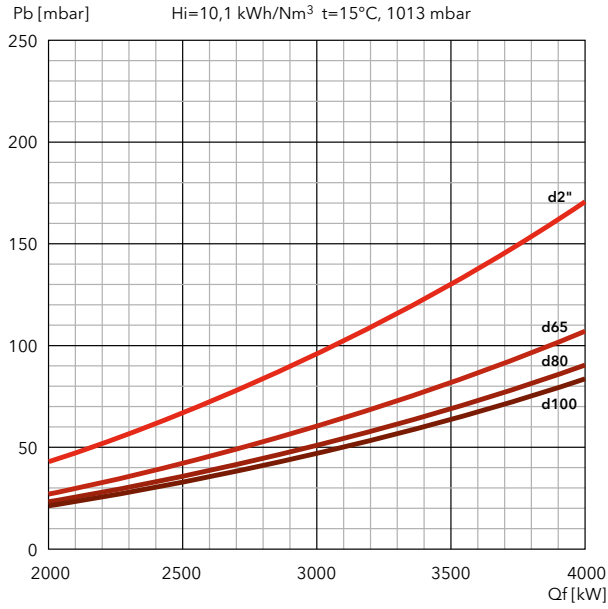

SIEMENS

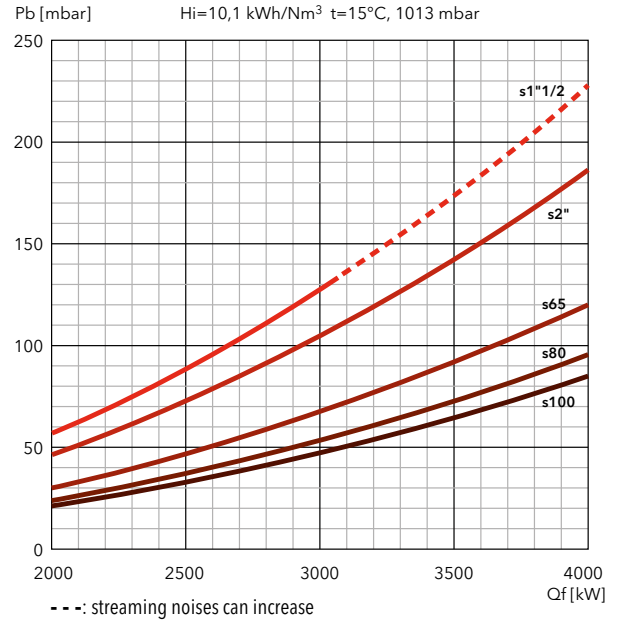

FILTERS

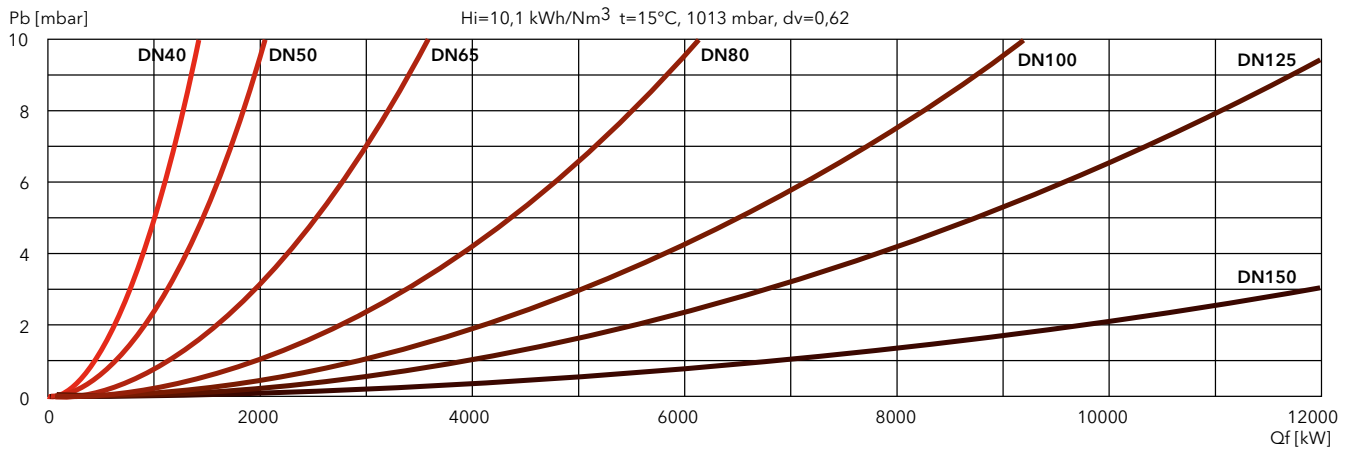

N6 G-EU2 / N7 G-EU2

340 ... 4290 kW

Two stage progressive/modulating electronic

- **Fuels:** natural gas, Hi = 6,99 ... 11,39 kWh/Nm³;
LPG, Hi = 25,89 kWh/Nm³
- **Emission class:** Low NOx class 3 (≤80 mg/kWh) according to EN676
- **Protection level:** IP 41



TECHNICAL DATA

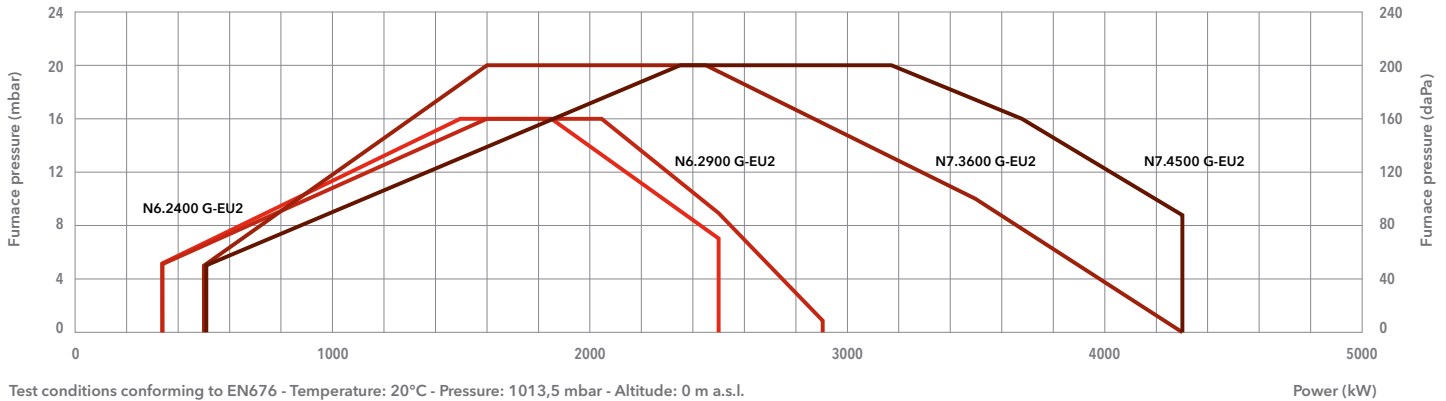

Test conditions conforming to EN676 - Temperature: 20°C - Pressure: 1013,5 mbar - Altitude: 0 m a.s.l.

	N6.2400 G-EU2	N6.2900 G-EU2	N7.3600 G-EU2	N7.4500 G-EU2
Operating range	340 - 2500 kW	360 - 2900 kW	490 - 4290 kW	510 - 4290 kW
Gas pressure	55 - 500 mbar (55 - 360 mbar for d452 and d453 gas train)	75 - 500 mbar (75 - 360 mbar for d452 and d453 gas train)	75 - 500 mbar (75 - 360 mbar for d452 and d453 gas train)	75 - 500 mbar (75 - 360 mbar for d452 and d453 gas train)
Gas connection	DN65	DN65	DN65	DN65
Control box / flame detector	BT300 / QRA2	BT300 / QRA2	BT300 / QRA2	BT300 / QRA2
Auxiliary voltage	1NPE AC 230 V - 50 Hz TN-S	1NPE AC 230 V - 50 Hz TN-S	1NPE AC 230 V - 50 Hz TN-S	1NPE AC 230 V - 50 Hz TN-S
Power supply	3PE AC 400 V - 50 Hz	3PE AC 400 V - 50 Hz	3PE AC 400 V - 50 Hz	3PE AC 400 V - 50 Hz
Fan motor	50 Hz - 3 kW	50 Hz - 4 kW	50 Hz - 5,5 kW	50 Hz - 7,5 kW
Acoustic level	<80 dB(A)	<80,5 dB(A)	<81,5 dB(A)	<84 dB(A)
CE certificate	0085CL0215	0085CL0215	0085CL0215	0085CL0215
Complete burner codes	on request	on request	on request	on request

GAS TRAINS

DUNGS

Model	Code
GT-d452-1"1/2 (*)	3750510
GT-d453-2" (*)	3750511
GT-d454-65	3750512
GT-d455-80	3750513
GT-d456-100	3750514

SIEMENS

Model	Code
GT-s451-1"1/2	3750525
GT-s452-2"	3750526
GT-s453-65	3750527
GT-s454-80	3750528
GT-s455-100	3750529
GT-s456-125	3750530

FILTERS

Model	Code
FG-Rp1"1/2	3757199
FG-Rp2"	3757200
FG-DN65	3757198
FG-DN80	3757201
FG-DN100	3757195
FG-DN125	3757209

*: integrated filter

i Pressure drops graphs: see following pages
Dimensions of gas trains and gas filters: see page 310



DIMENSIONS (mm)

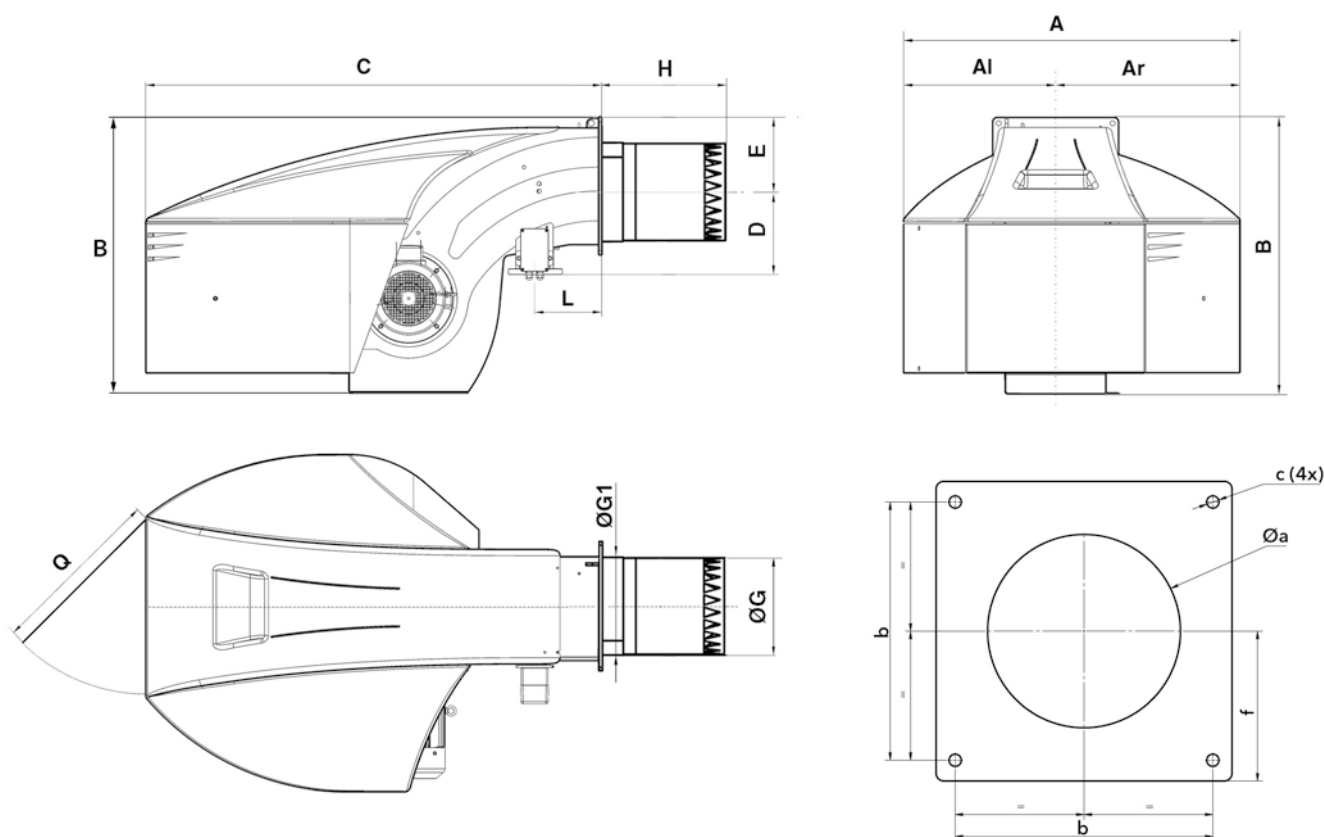

Model	A	AI	Ar	B	C	D	E	ØG	ØG1	H			L	Q	Øa	b	c	f
										KN	KM	KL						
N6... G-EU2	990	479	511	837	1358	245	225	263	277	400	520	640	215	600	330-340	340	M16	200
N7... G-EU2	1127	509	618	961	1527	276	255	325	343	420	550	680	225	600	360-400	400	M16	235

PACKAGING

The burner is delivered on a pallet with:

- burner body with mounted combustion head
- gas train and filter
- boiler fixing accessories
- technical documentation

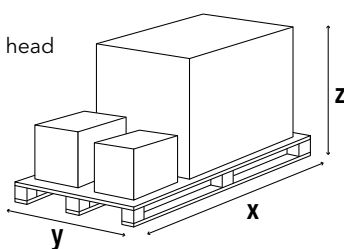

Model	Dimensions (mm)			Gross weight (kg)
	X	Y	Z	
N6.2400 G-EU2	2300	1500	1573	360
N6.2900 G-EU2	2300	1500	1573	360
N7.3600 G-EU2	2300	1500	1573	450
N7.4500 G-EU2	2300	1500	1573	450

N6 G-EU2 / N7 G-EU2

340 ... 4290 kW

Two stage progressive/modulating electronic

PRESSURE LOSS [BURNER HEAD + GAS TRAIN] (mbar)

N6.2400 G-EU2

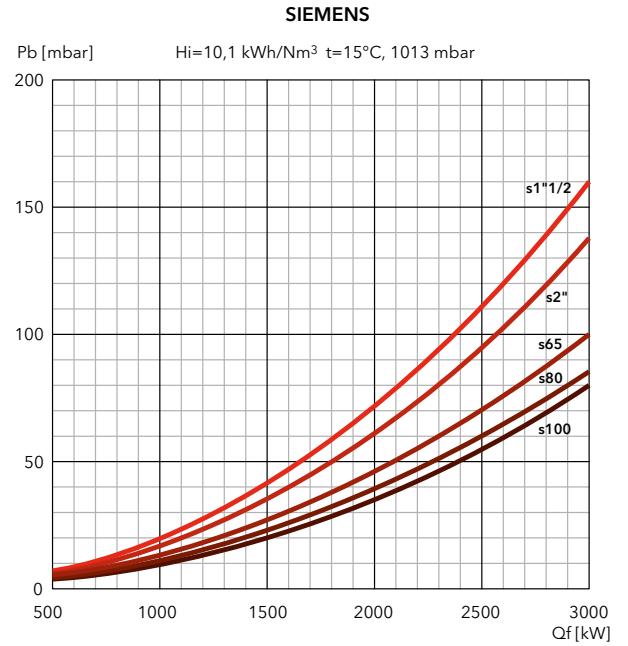
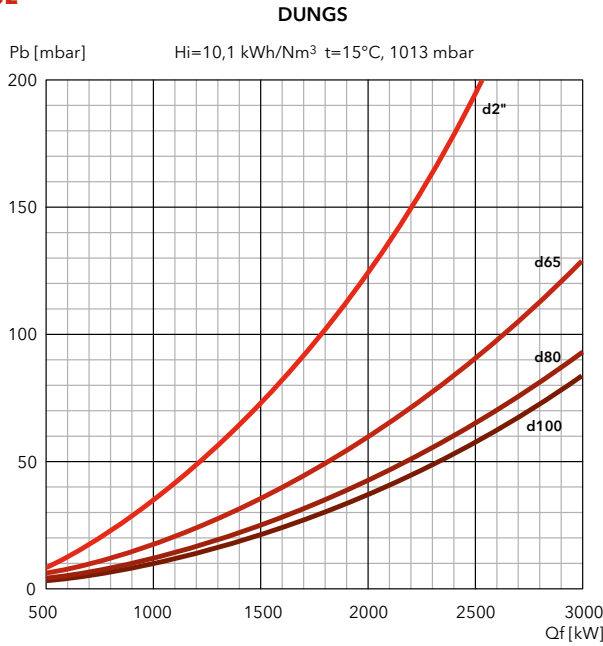

N6.2900 G-EU2

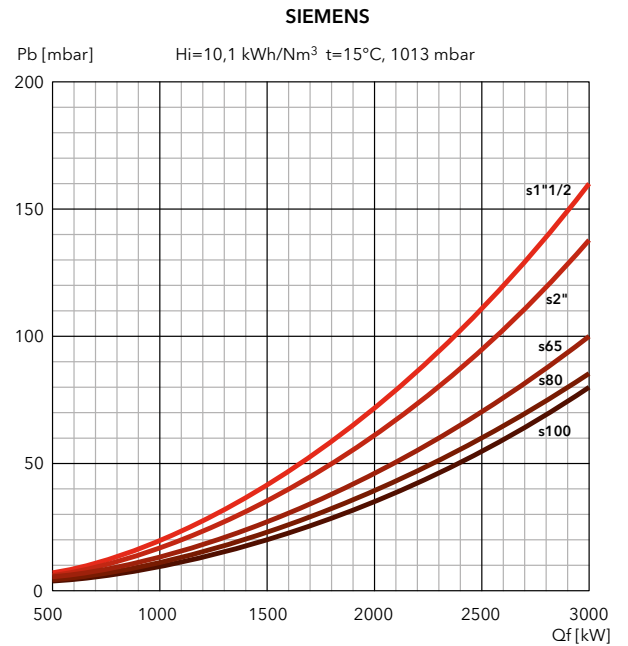
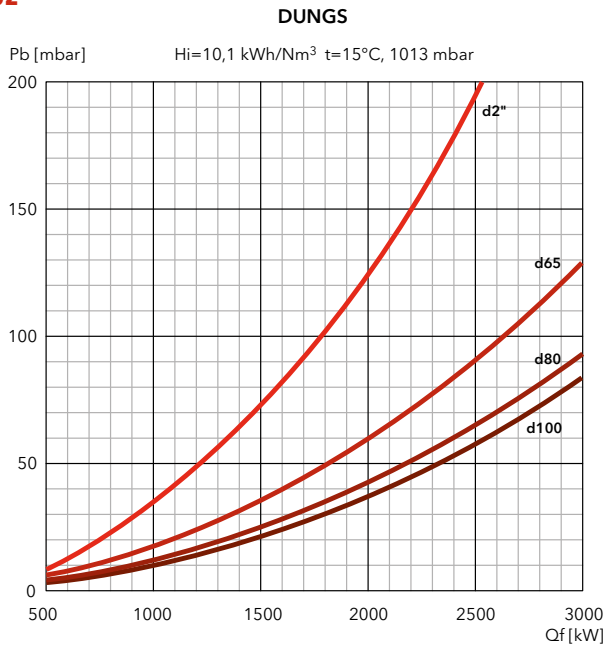

FILTERS

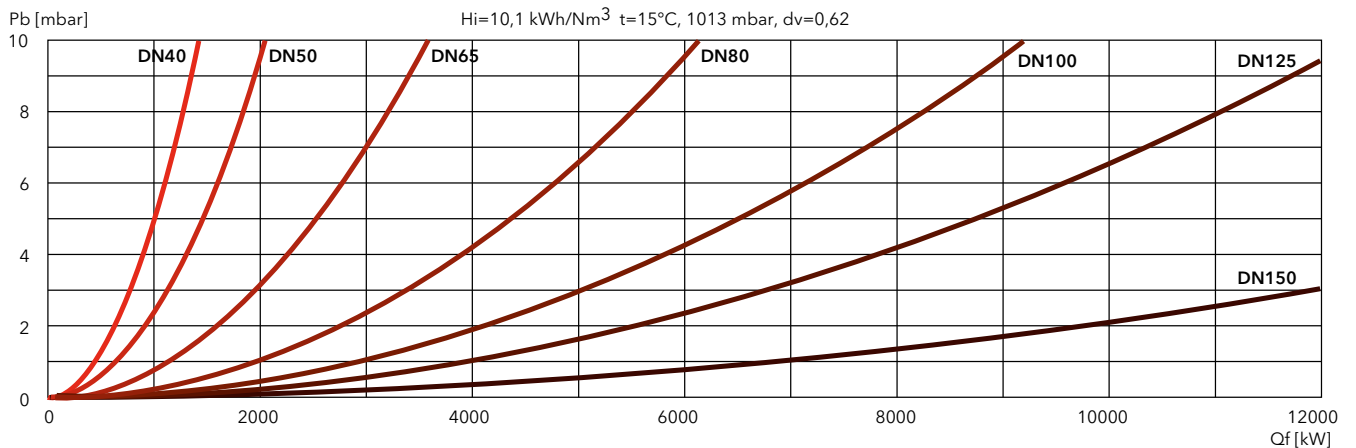



PRESSURE LOSS [BURNER HEAD + GAS TRAIN] (mbar)

N7.3600 G-EU2

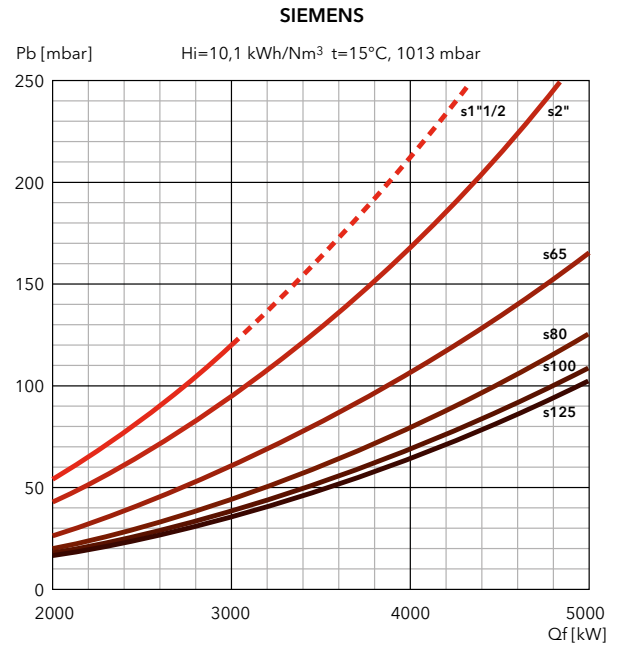
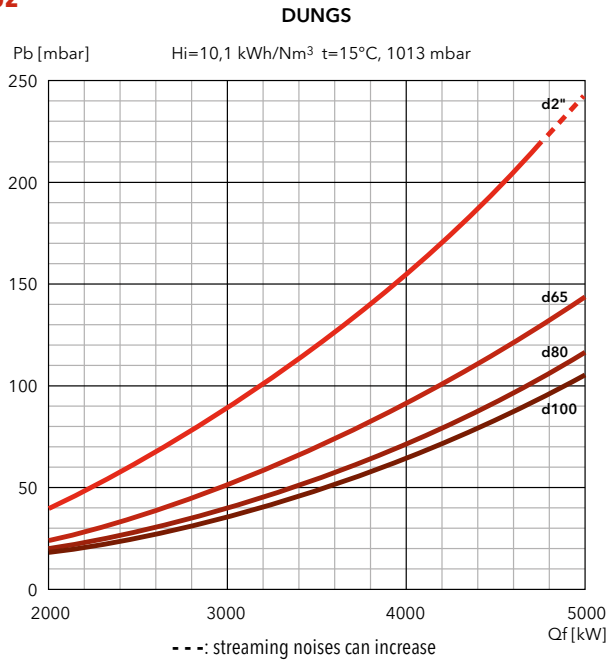

N7.4500 G-EU2

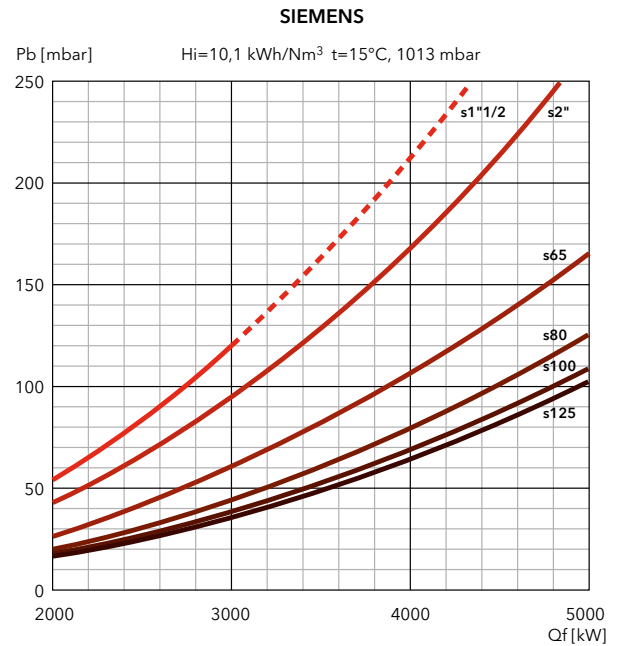
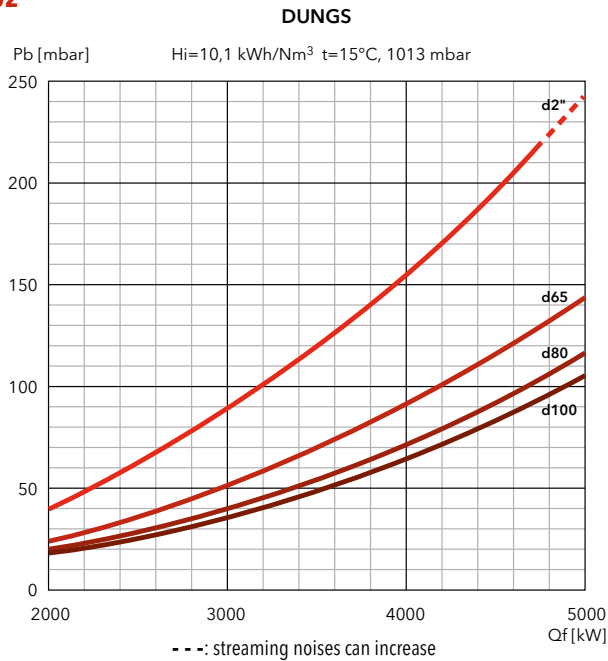

FILTERS

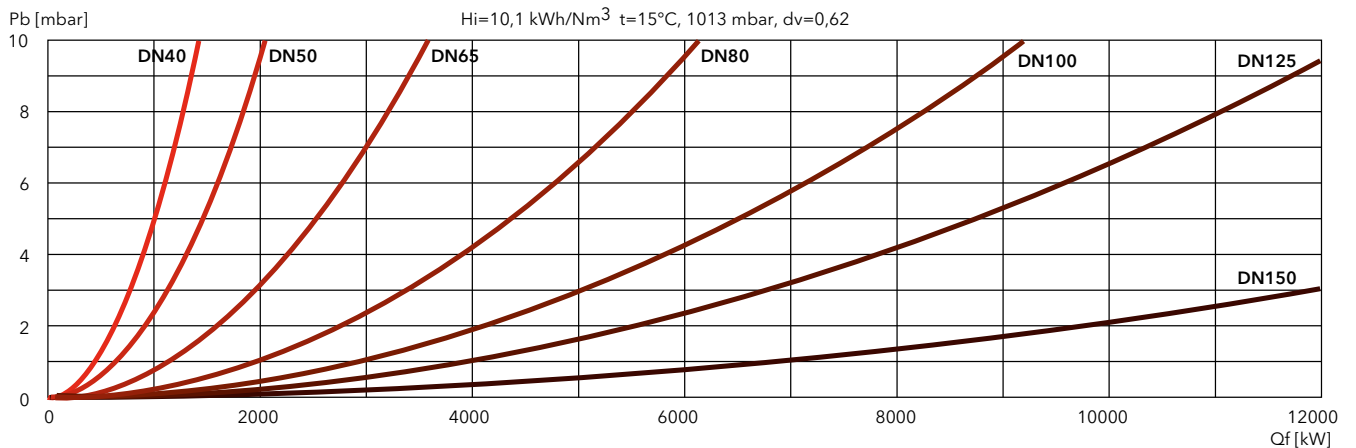

N9 G-EU2N

970 ... 8250 kW

Two stage progressive/modulating electronic



- **Fuels:** natural gas, Hi = 6,99 ... 11,39 kWh/Nm³;
LPG, Hi = 25,89 kWh/Nm³
- **Emission class:** Low NOx class 3 (≤80 mg/kWh) according to EN676
- **Protection level:** IP 41

TECHNICAL DATA

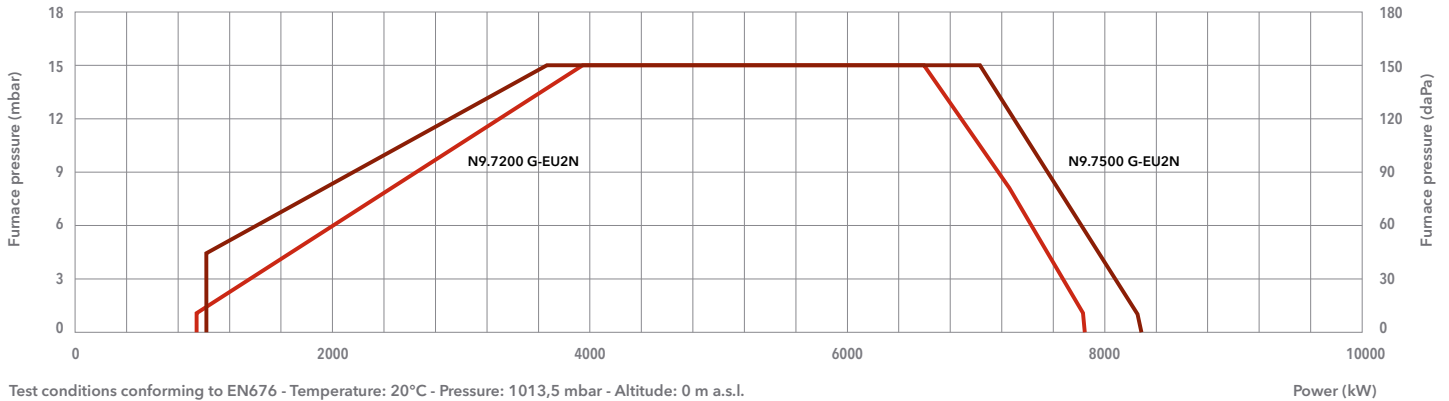

Test conditions conforming to EN676 - Temperature: 20°C - Pressure: 1013,5 mbar - Altitude: 0 m a.s.l.

	N9.7200 G-EU2N	N9.7500 G-EU2N
Operating range	970 – 7840 kW	1020 – 8250 kW
Gas pressure	150 – 500 mbar (150 – 360 mbar for d457 gas train)	120 – 500 mbar (120 – 360 mbar for d457 gas train)
Gas connection	DN100	DN100
Control box / flame detector	BT300 / QRA2	BT300 / QRA2
Auxiliary voltage	1NPE AC 230 V – 50 Hz TN-S	1NPE AC 230 V – 50 Hz TN-S
Power supply	3PE AC 400 V – 50 Hz	3PE AC 400 V – 50 Hz
Fan motor	50 Hz – 22 kW	50 Hz – 22 kW
Acoustic level	<81,7 dB(A)	<81,7 dB(A)
CE certificate	0085CLO215	0085CLO215
Complete burner codes	on request	on request

GAS TRAINS

DUNGS

Model	Code
GT-d457-2" (*)	3750515
GT-d458-65	3750516
GT-d459-80	3750517
GT-d460-100	3750518

SIEMENS

Model	Code
GT-s458-65	3750538
GT-s459-80	3750539
GT-s460-100	3750540
GT-s461-125	3750541

FILTERS

Model	Code
FG-DN65	3757198
FG-DN80	3757201
FG-DN100	3757195
FG-DN125	3757209

*: integrated filter

i **Pressure drops graphs:** see following pages
Dimensions of gas trains and gas filters: see page 311



DIMENSIONS (mm)

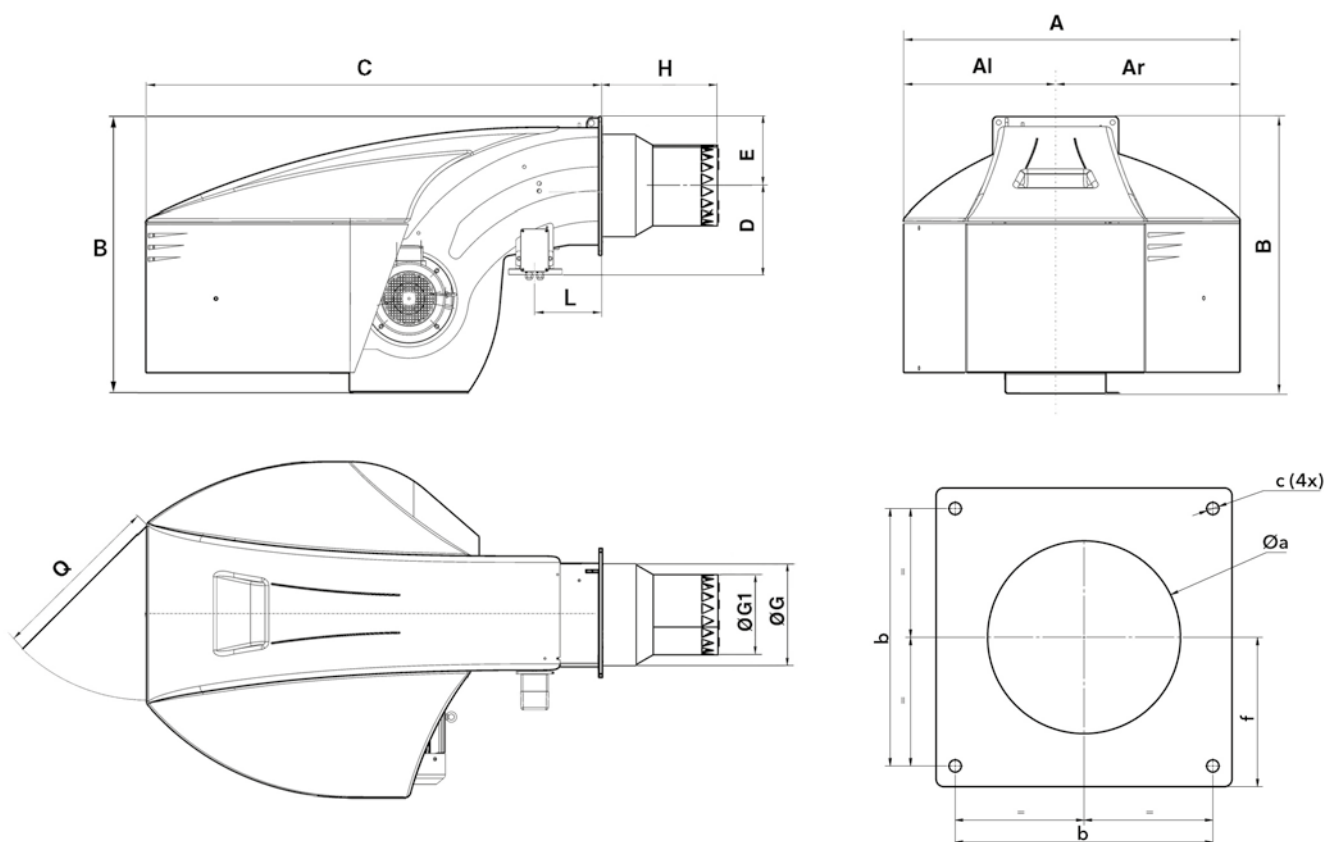

Model	A	Al	Ar	B	C	D	E	ØG	ØG1	H			L	Q	Øa	b	c	f
										KN	KM	KL						
N9.7200 G-EU2N	1414	669	745	1291	1928	369	293	439	346	500	640	780	230	800	460-480	505	M20	293
N9.7500 G-EU2N	1414	669	745	1291	1928	369	293	439	369	550	700	850	230	800	460-480	505	M20	293

PACKAGING

The burner is delivered on a pallet with:

- burner body with mounted combustion head
- gas train and filter
- boiler fixing accessories
- technical documentation

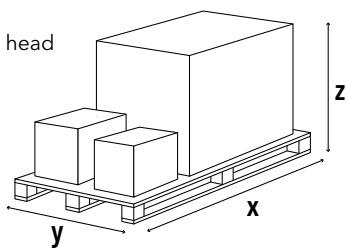

Model	Dimensions (mm)			Gross weight (kg)
	X	Y	Z	
N9.7200 G-EU2N	2900	1600	1573	760
N9.7500 G-EU2N	2900	1600	1573	760

N9 G-EU2N

970 ... 8250 kW

Two stage progressive/modulating electronic

PRESSURE LOSS [BURNER HEAD + GAS TRAIN] (mbar)

N9.7200 G-EU2N

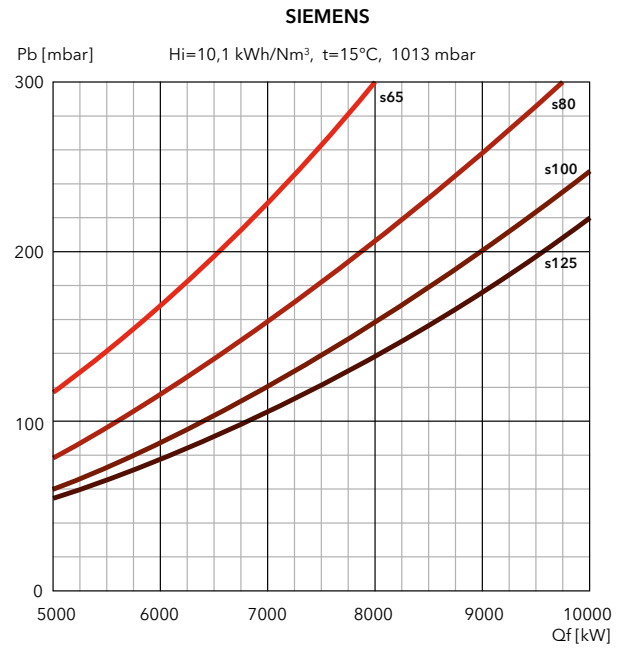
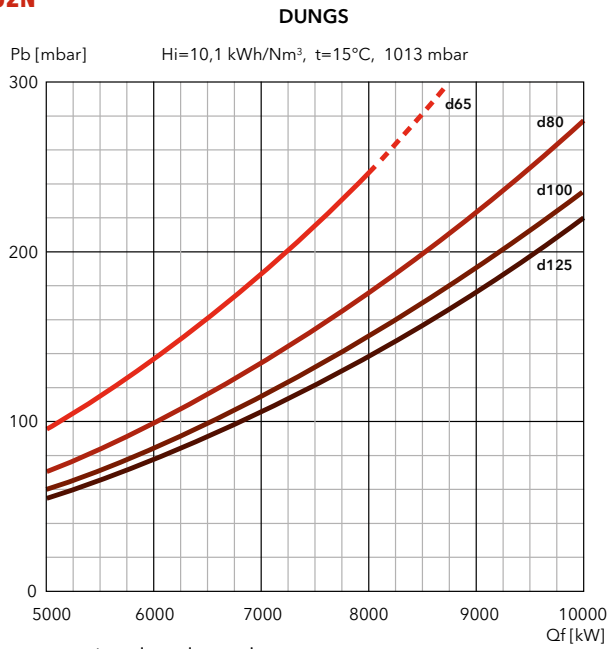

FILTERS

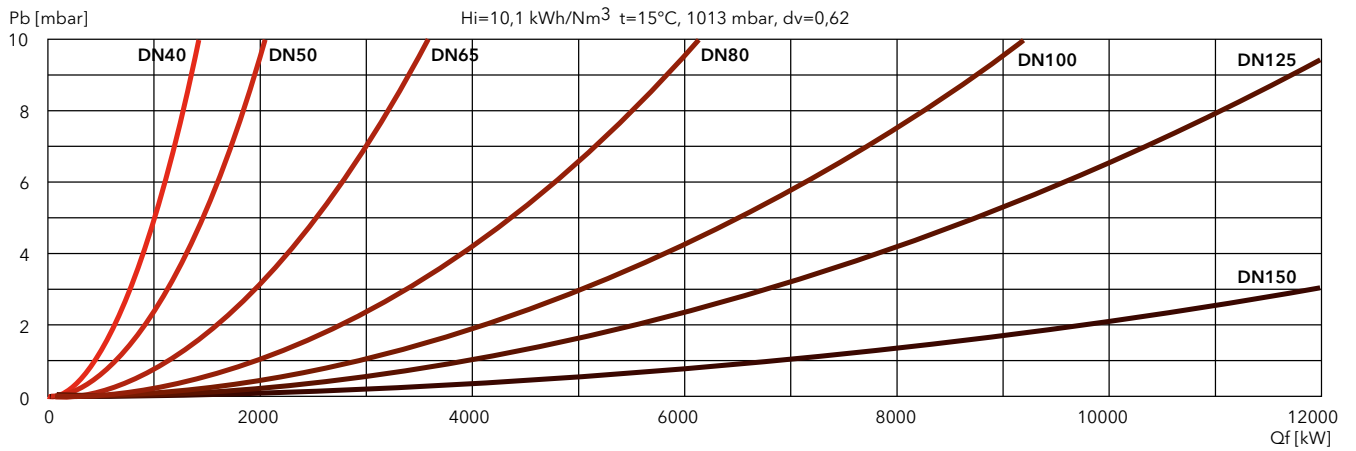



PRESSURE LOSS [BURNER HEAD + GAS TRAIN] (mbar)

N9.7500 G-EU2N

DUNGS

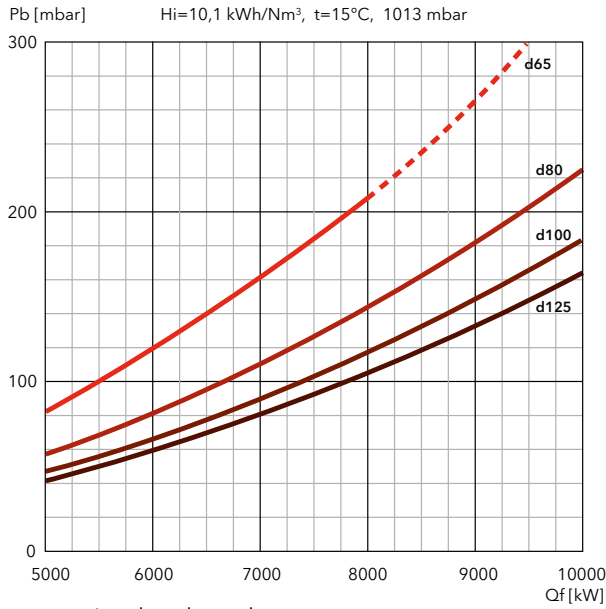

SIEMENS

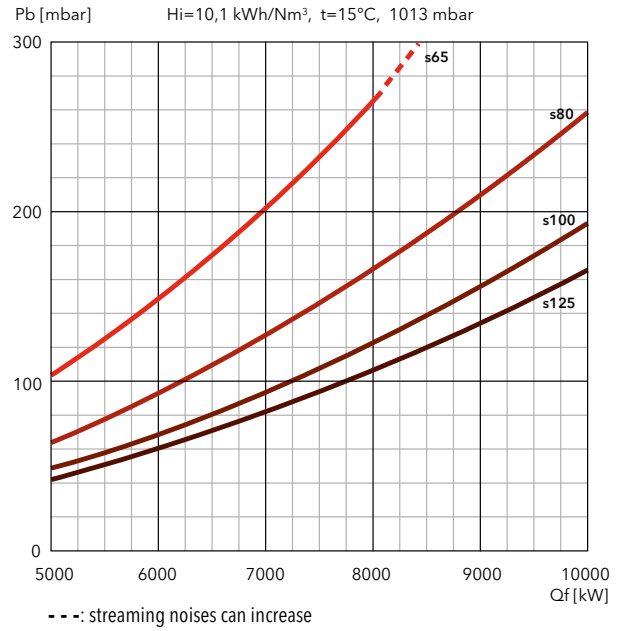

FILTERS

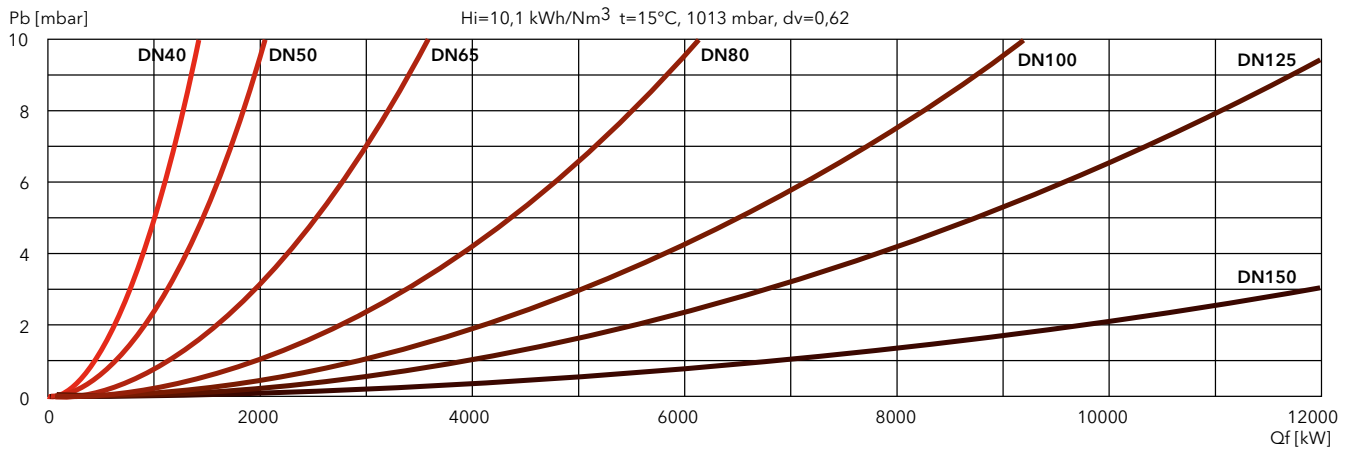

N6 G-E / N7 G-E

390 ... 5000 kW

Two stage progressive/modulating electronic

- **Fuels:** natural gas, Hi = 6,99 ... 11,39 kWh/Nm³;
LPG, Hi = 25,89 kWh/Nm³
- **Emission class:** Low NOx class 2 (≤120 mg/kWh) according to EN676
- **Protection level:** IP 41



TECHNICAL DATA

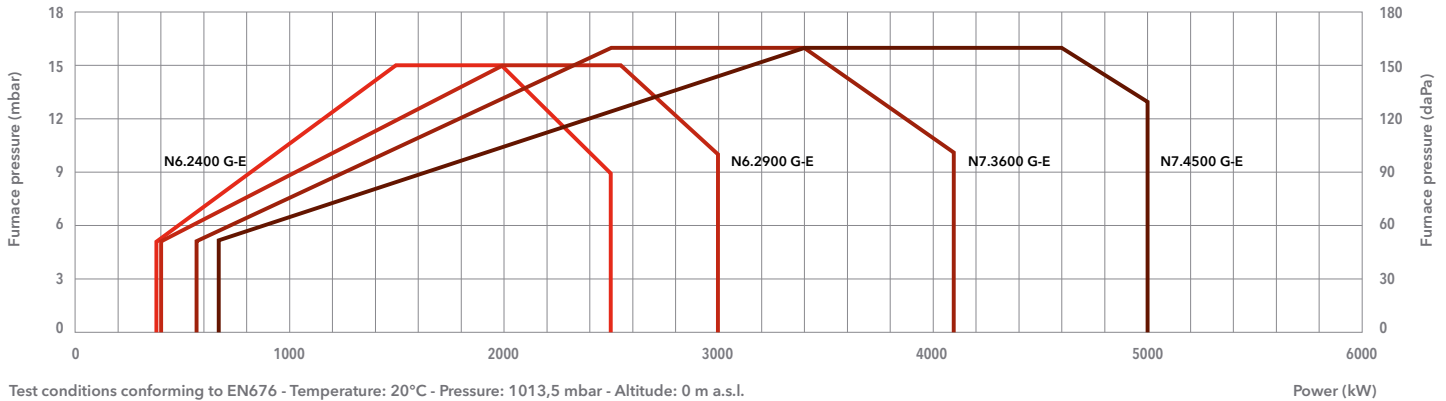

Test conditions conforming to EN676 - Temperature: 20°C - Pressure: 1013,5 mbar - Altitude: 0 m a.s.l.

	N6.2400 G-E	N6.2900 G-E	N7.3600 G-E	N7.4500 G-E
Operating range	390 – 2500 kW	400 – 3000 kW	580 – 4100 kW	680 – 5000 kW
Gas pressure	50 – 500 mbar (50 – 360 mbar for d452 and d453 gas train)		50 – 500 mbar (50 – 360 mbar for d452 and d453 gas train)	
Gas connection	DN65	DN65	DN65	DN65
Control box / flame detector	BT300 / Ionisation	BT300 / Ionisation	BT300 / Ionisation	BT300 / Ionisation
Auxiliary voltage	1NPE AC 230 V – 50 Hz TN-S	1NPE AC 230 V – 50 Hz TN-S	1NPE AC 230 V – 50 Hz TN-S	1NPE AC 230 V – 50 Hz TN-S
Power supply	3PE AC 400 V – 50 Hz	3PE AC 400 V – 50 Hz	3PE AC 400 V – 50 Hz	3PE AC 400 V – 50 Hz
Fan motor	50 Hz – 3 kW	50 Hz – 4 kW	50 Hz – 5,5 kW	50 Hz – 7,5 kW
Acoustic level	<70 dB(A)	<71 dB(A)	<74 dB(A)	<75 dB(A)
CE certificate	0085CL0215	0085CL0215	0085CL0215	0085CL0215
Complete burner codes	on request	on request	on request	on request

GAS TRAINS

DUNGS

Model	Code
GT-d452-1"1/2 (*)	3750510
GT-d453-2" (*)	3750511
GT-d454-65	3750512
GT-d455-80	3750513
GT-d456-100	3750514

SIEMENS

Model	Code
GT-s451-1"1/2	3750525
GT-s452-2"	3750526
GT-s453-65	3750527
GT-s454-80	3750528
GT-s455-100	3750529
GT-s456-125	3750530

FILTERS

Model	Code
FG-Rp1"1/2	3757199
FG-Rp2"	3757200
FG-DN65	3757198
FG-DN80	3757201
FG-DN100	3757195
FG-DN125	3757209

*: integrated filter

i **Pressure drops graphs:** see following pages
Dimensions of gas trains and gas filters: see page 310



DIMENSIONS (mm)

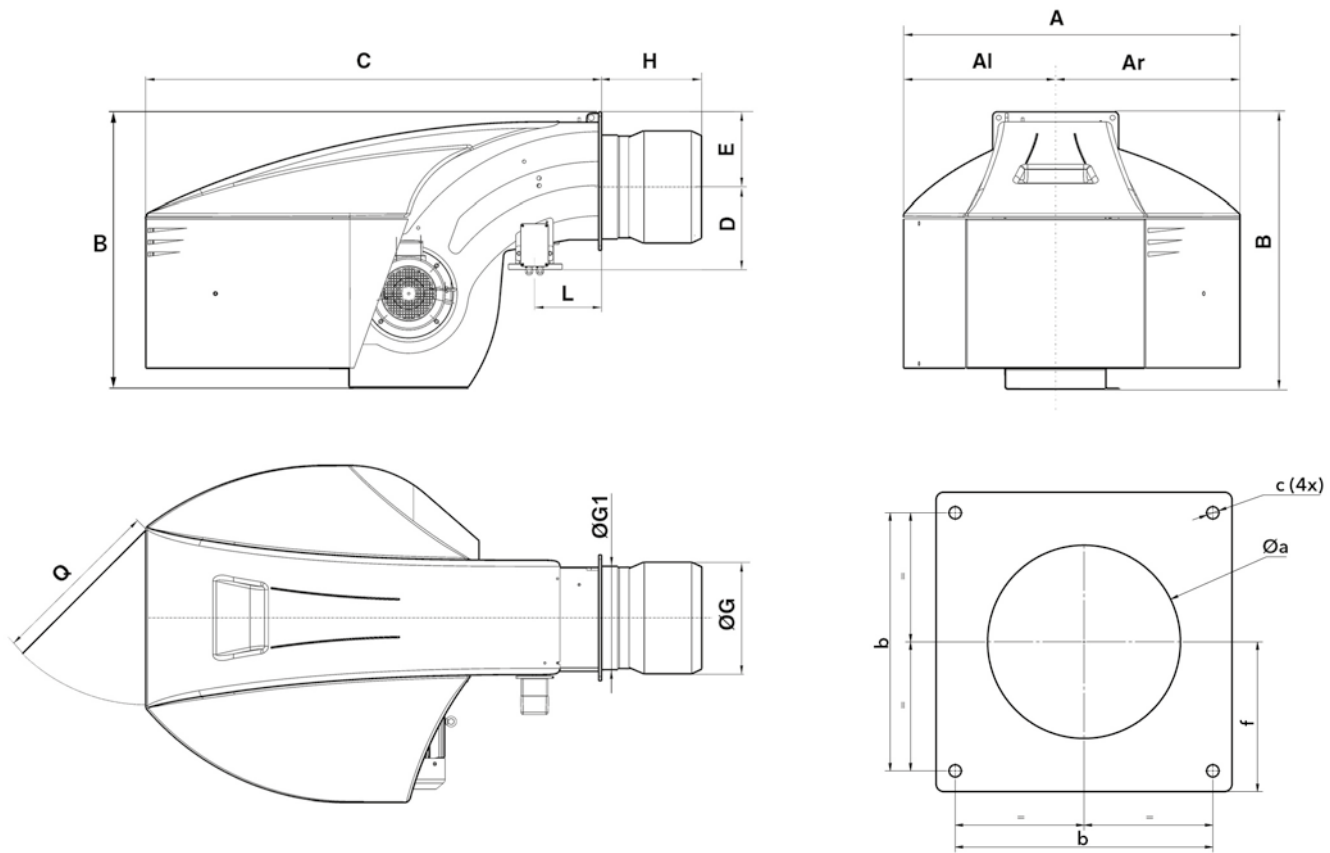

Model	A	Al	Ar	B	C	D	E	ØG	ØG1	H			L	Q	Øa	b	c	f
										KN	KM	KL						
N6... G-E	989	479	510	837	1361	245	225	320	270	330	450	570	215	600	330-340	340	M16	200
N7... G-E	1128	511	618	961	1529	276	255	370	332	375	505	635	225	600	380-400	400	M16	235

PACKAGING

The burner is delivered on a pallet with:

- burner body with mounted combustion head
- gas train and filter
- boiler fixing accessories
- technical documentation

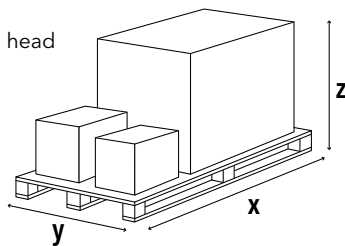

Model	Dimensions (mm)			Gross weight (kg)
	X	Y	Z	
N6.2400 G-E	2300	1500	1573	360
N6.2900 G-E	2300	1500	1573	360
N7.3600 G-E	2300	1500	1573	450
N7.4500 G-E	2300	1500	1573	450

N6 G-E / N7 G-E

390 ... 5000 kW

Two stage progressive/modulating electronic

PRESSURE LOSS [BURNER HEAD + GAS TRAIN] (mbar)

N6.2400 G-E

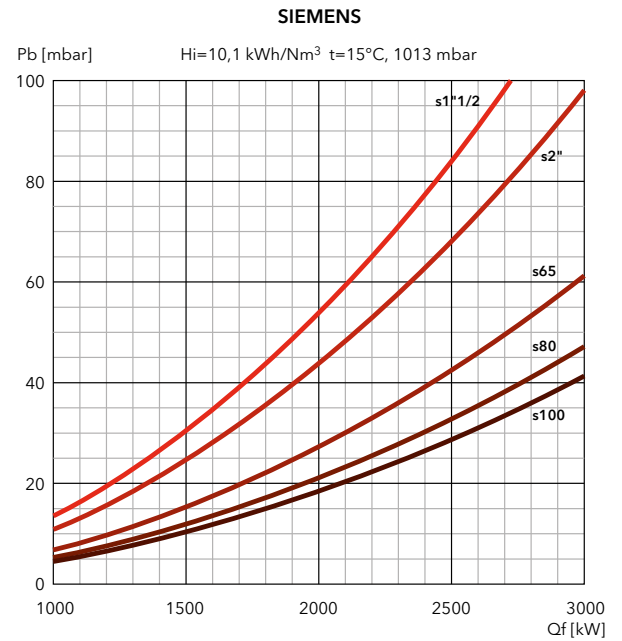
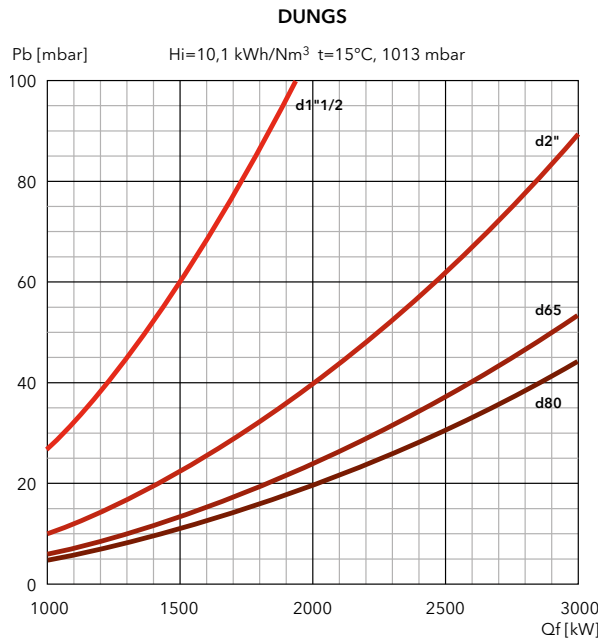

N6.2900 G-E

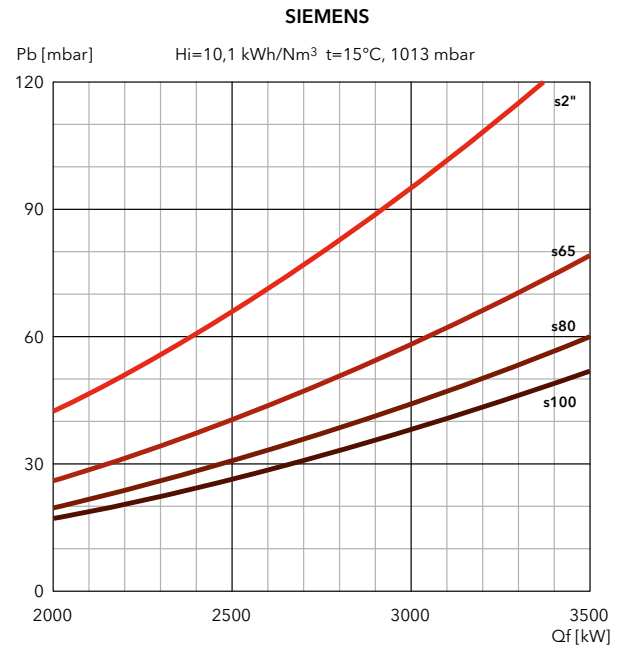
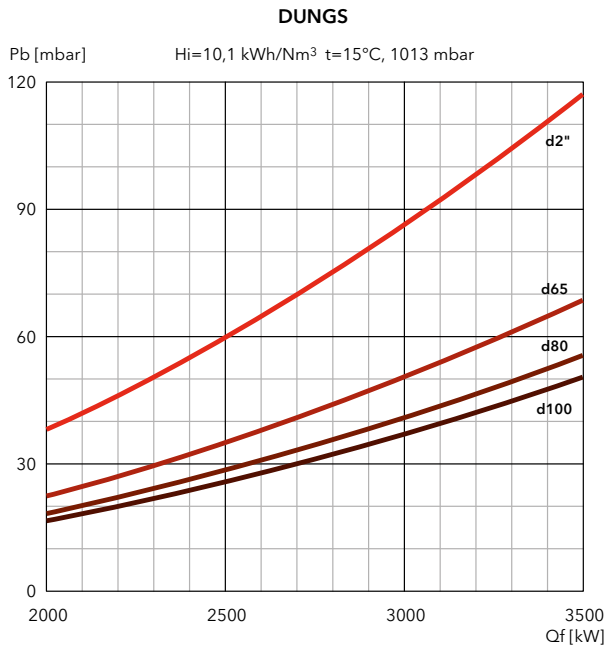

FILTERS

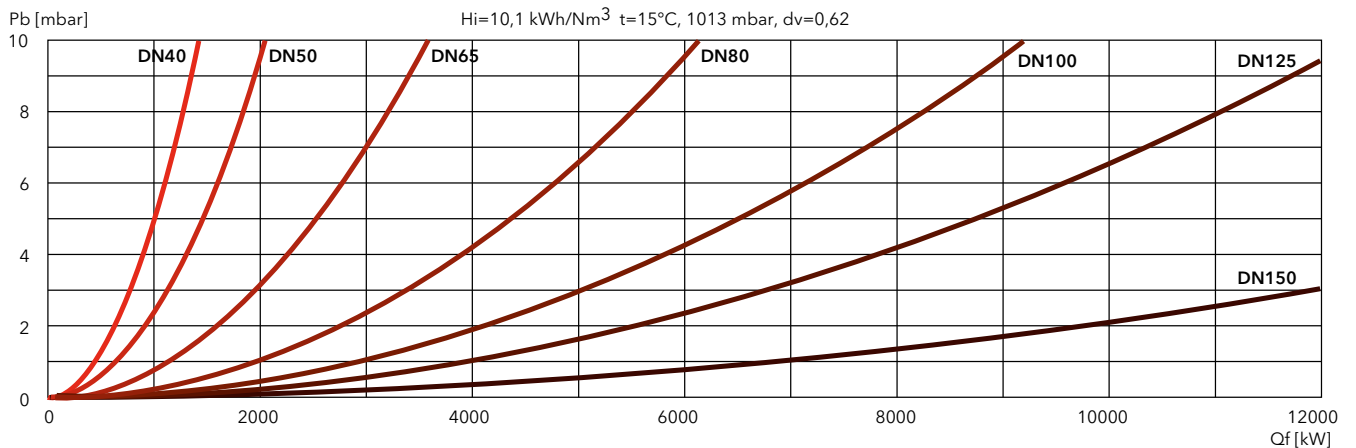



PRESSURE LOSS [BURNER HEAD + GAS TRAIN] (mbar)

N7.3600 G-E

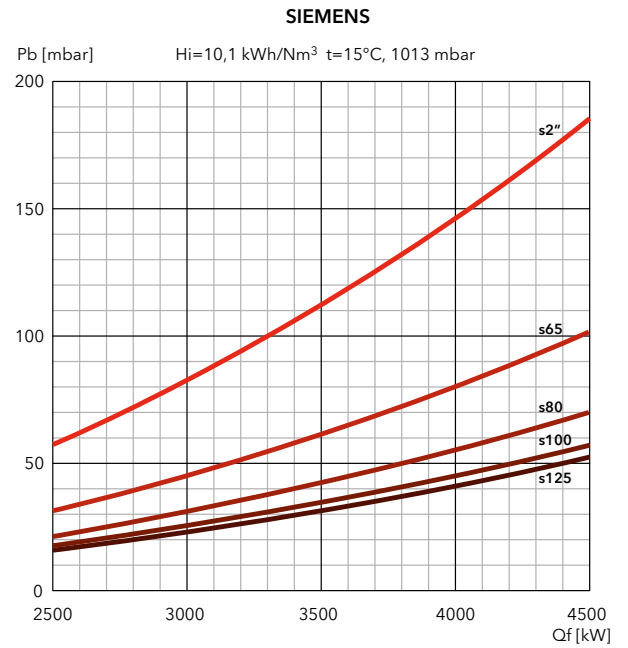
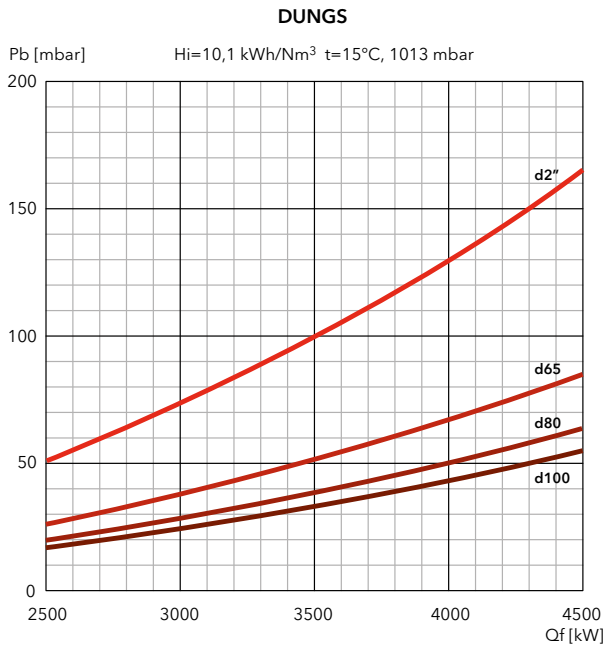

N7.4500 G-E

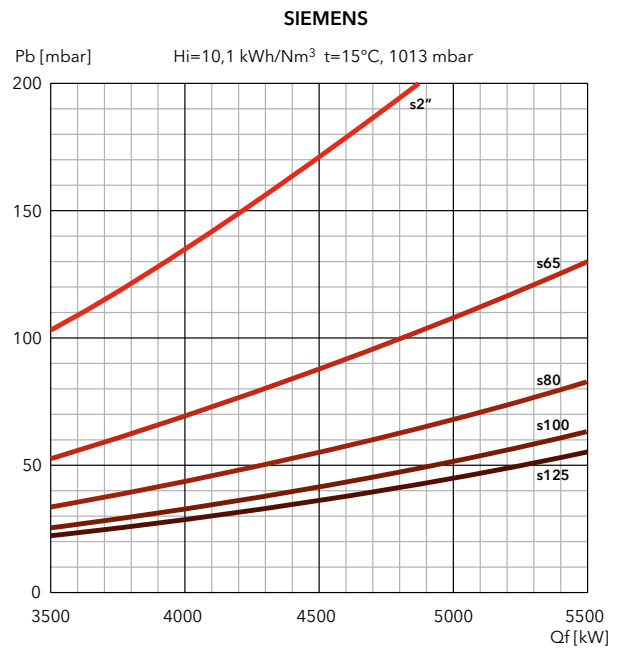
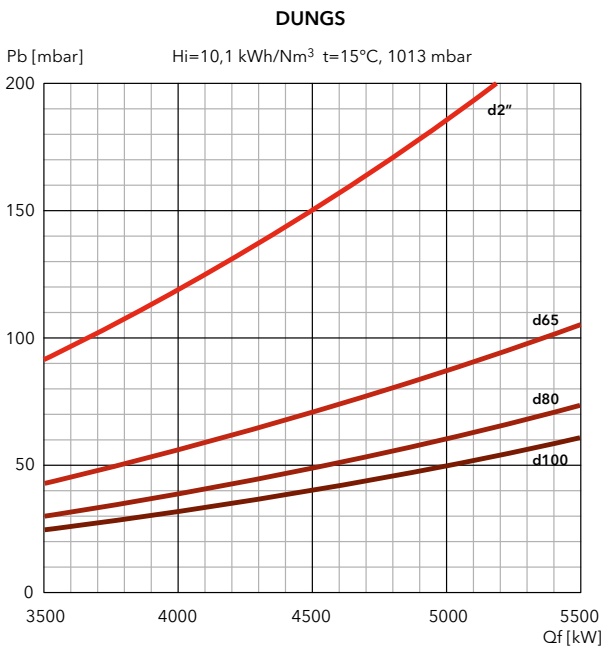

FILTERS

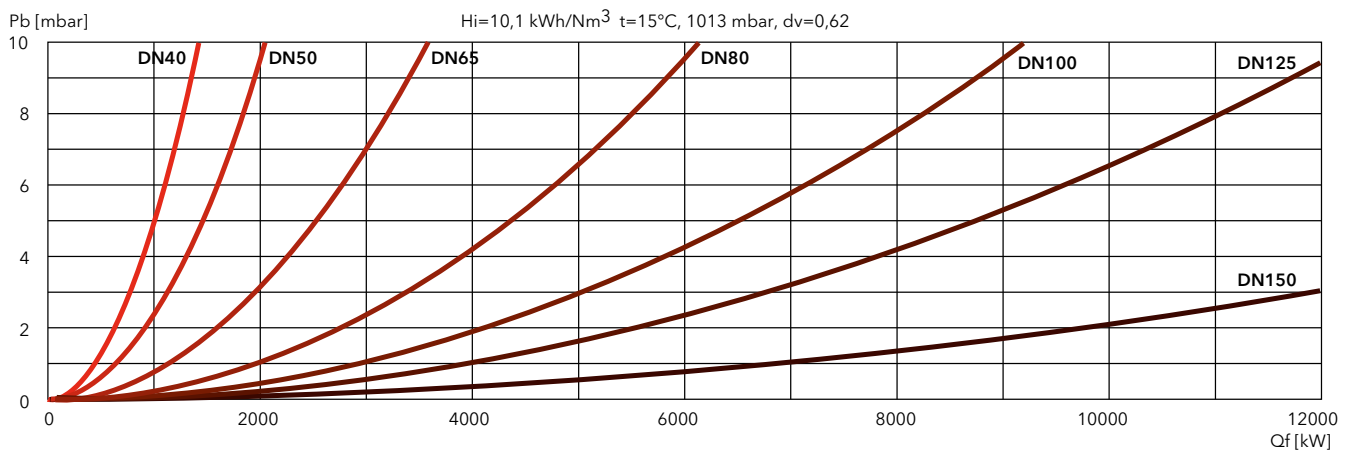

N8 G-E / N9 G-E

740 ... 11200 kW

Two stage progressive/modulating electronic



- **Fuels:** natural gas, Hi = 6,99 ... 11,39 kWh/Nm³;
LPG, Hi = 25,89 kWh/Nm³
- **Emission class:** Low NOx class 2 (≤120 mg/kWh) according to EN676
- **Modulating ratio:** 1:10
- **Protection level:** IP 41

TECHNICAL DATA

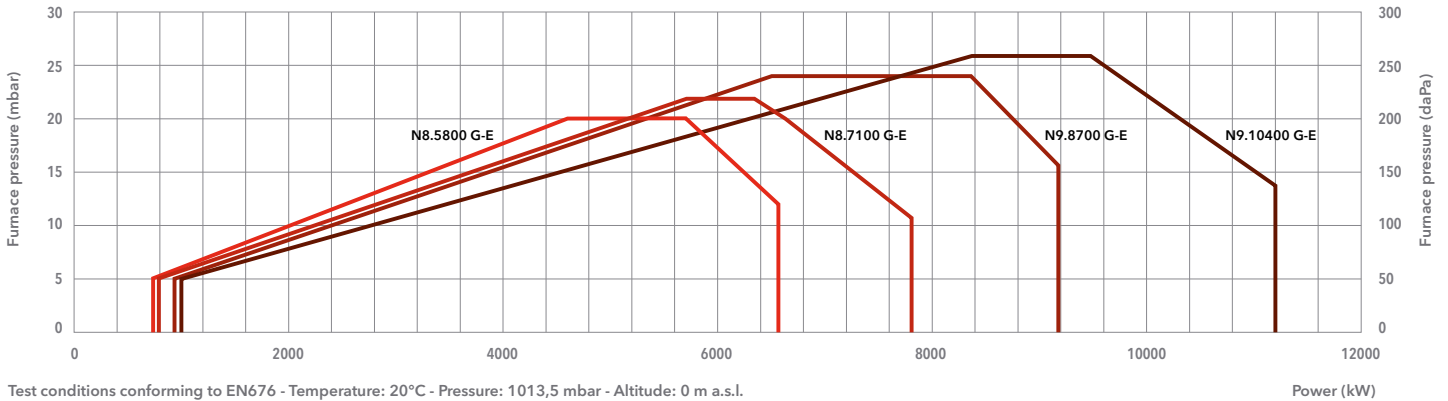

Test conditions conforming to EN676 - Temperature: 20°C - Pressure: 1013,5 mbar - Altitude: 0 m a.s.l.

	N8.5800 G-E	N8.7100 G-E	N9.8700 G-E	N9.10400 G-E
Operating range	740 - 6570 kW	800 - 7800 kW	880 - 9200 kW	960 - 11200 kW
Gas pressure	60 - 500 mbar (60 - 360 mbar for d457 gas train)		70 - 500 mbar (70 - 360 mbar for d457 gas train)	
Gas connection	DN100	DN100	DN100	DN100
Control box / flame detector	BT300 / Ionisation	BT300 / Ionisation	BT300 / Ionisation	BT300 / Ionisation
Auxiliary voltage	1NPE AC 230 V - 50 Hz TN-S	1NPE AC 230 V - 50 Hz TN-S	1NPE AC 230 V - 50 Hz TN-S	1NPE AC 230 V - 50 Hz TN-S
Power supply	3PE AC 400 V - 50 Hz	3PE AC 400 V - 50 Hz	3PE AC 400 V - 50 Hz	3PE AC 400 V - 50 Hz
Fan motor	50 Hz - 11 kW	50 Hz - 15 kW	50 Hz - 18,5 kW	50 Hz - 22 kW
Acoustic level	<78 dB(A)	<78 dB(A)	<80 dB(A)	<81 dB(A)
CE certificate	0085CL0215	0085CL0215	0085CL0215	0085CL0215
Complete burner codes	on request	on request	on request	on request

GAS TRAINS

DUNGS

Model	Code
GT-d457-2" (*)	3750515
GT-d458-65	3750516
GT-d459-80	3750517
GT-d460-100	3750518

SIEMENS

Model	Code
GT-s457-2"	3750537
GT-s458-65	3750538
GT-s459-80	3750539
GT-s460-100	3750540
GT-s461-125	3750541

FILTERS

Model	Code
FG-Rp2"	3757200
FG-DN65	3757198
FG-DN80	3757201
FG-DN100	3757195
FG-DN125	3757209

*: integrated filter

i **Pressure drops graphs:** see following pages
Dimensions of gas trains and gas filters: see page 311



DIMENSIONS (mm)

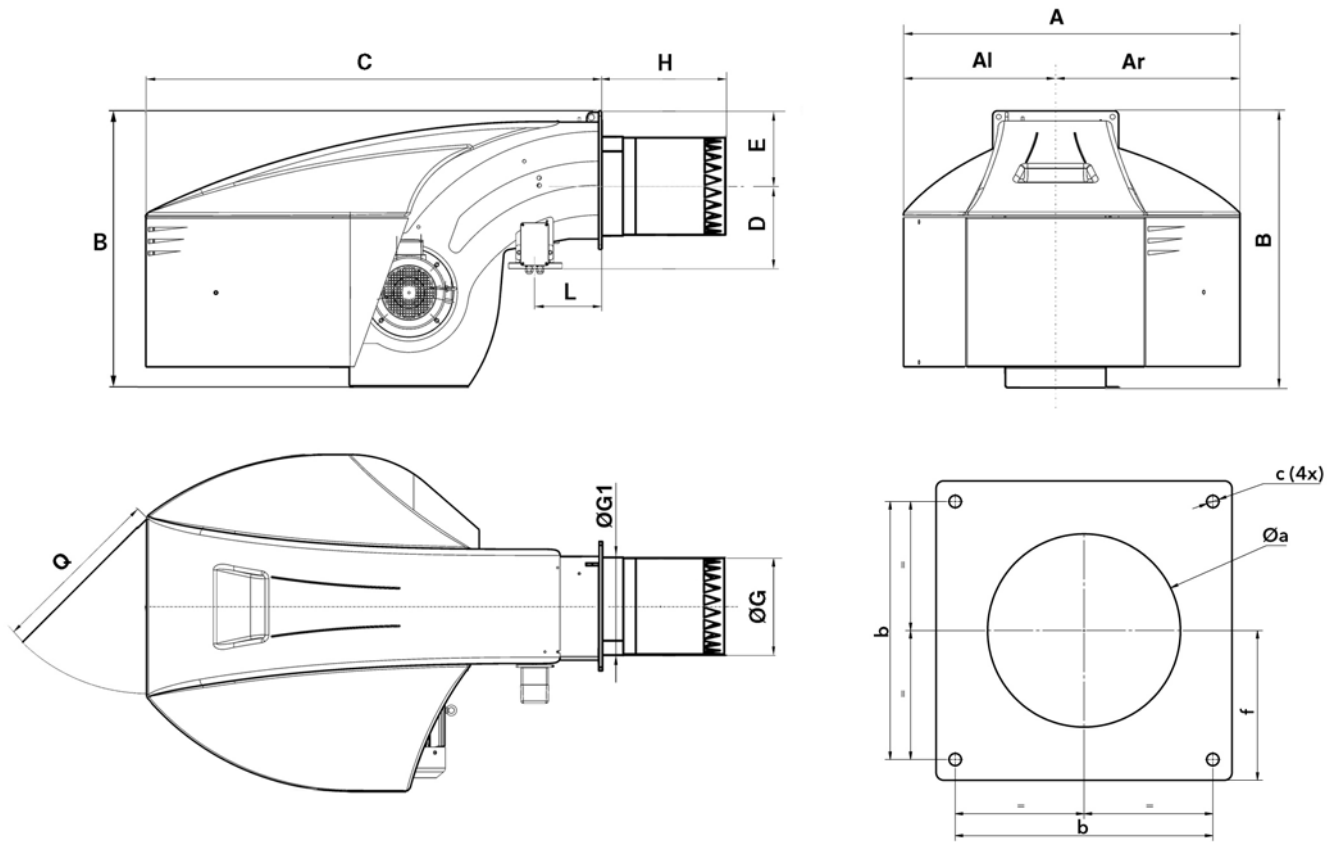

Model	A	Al	Ar	B	C	D	E	ØG	ØG1	H			L	Q	Øa	b	c	f
										KN	KM	KL						
N8... G-E	1414	669	745	1231	1930	344	293	369	377	500	640	780	230	800	390-410	505	M20	293
N9... G-E	1414	669	745	1291	1930	372	293	431,5	439,5	550	700	850	230	800	460-480	505	M20	293

PACKAGING

The burner is delivered on a pallet with:

- burner body with mounted combustion head
- gas train and filter
- boiler fixing accessories
- technical documentation

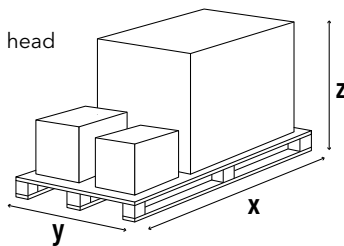

Model	Dimensions (mm)			Gross weight (kg)
	X	Y	Z	
N8.5800 G-E	2900	1600	1573	700
N8.7100 G-E	2900	1600	1573	700
N9.8700 G-E	2900	1600	1573	760
N9.10400 G-E	2900	1600	1573	760

N8 G-E / N9 G-E

740 ... 11200 kW

Two stage progressive/modulating electronic

PRESSURE LOSS [BURNER HEAD + GAS TRAIN] (mbar)

N8.5800 G-E

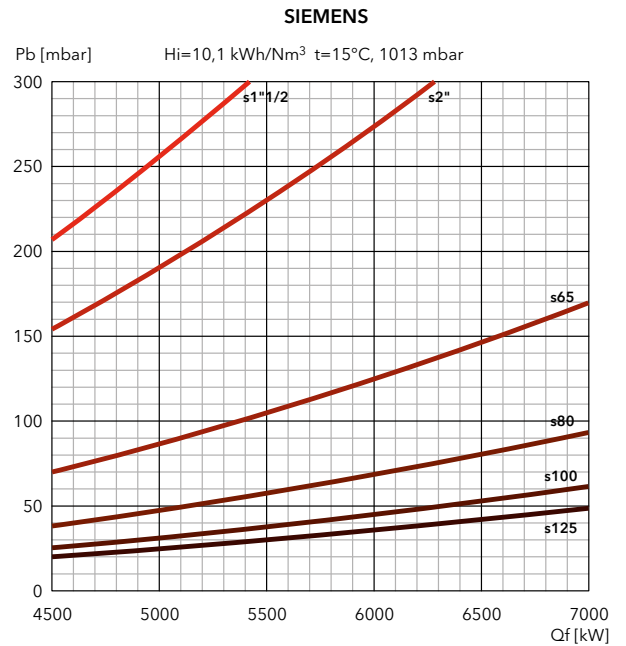
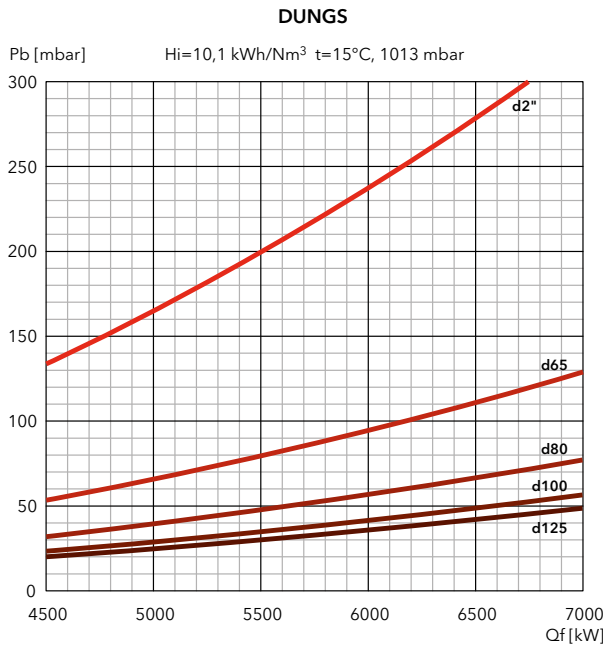

N8.7100 G-E

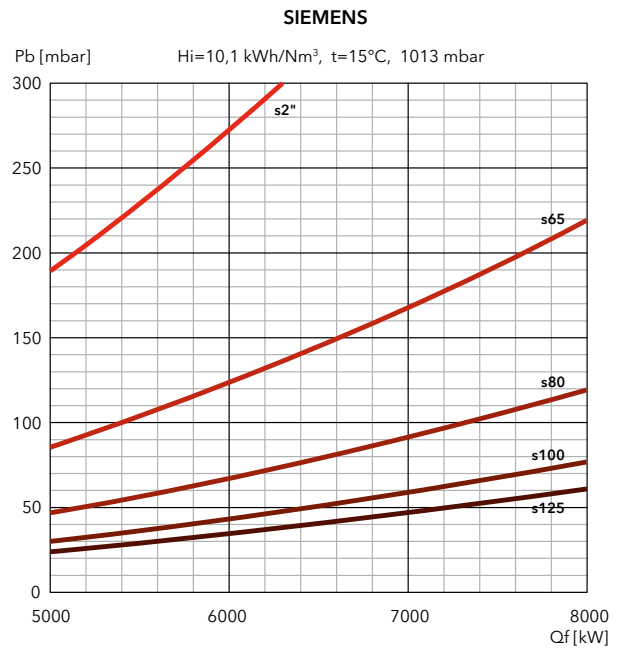
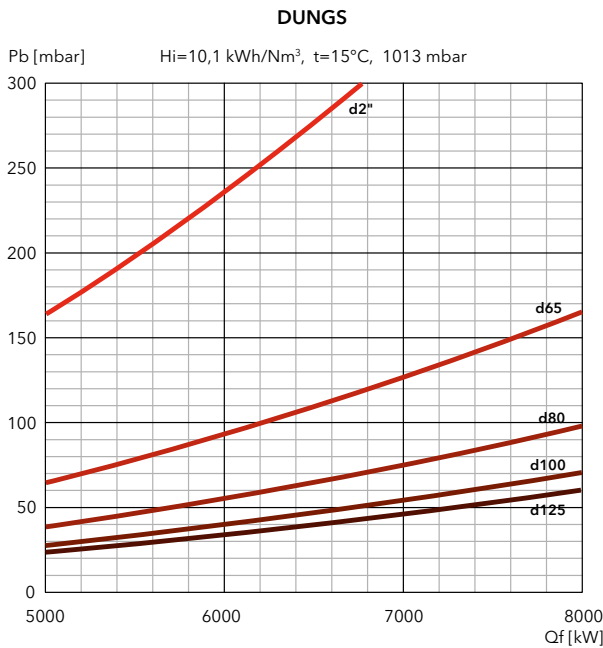

FILTERS

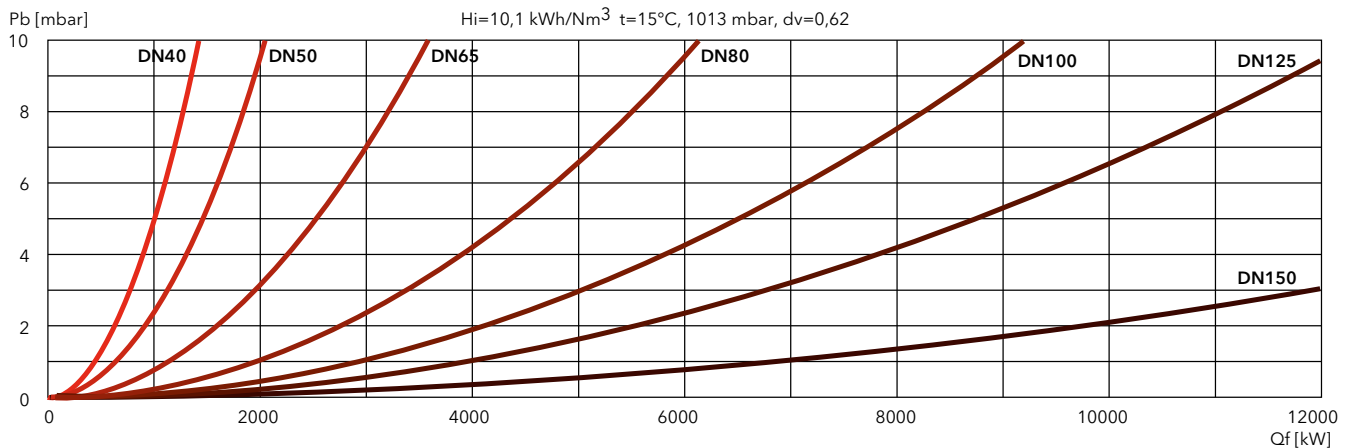



PRESSURE LOSS [BURNER HEAD + GAS TRAIN] (mbar)

N9.8700 G-E

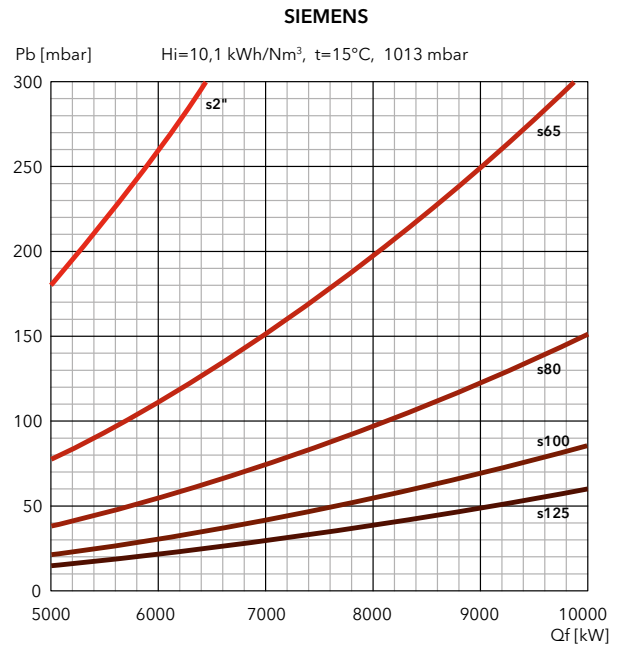
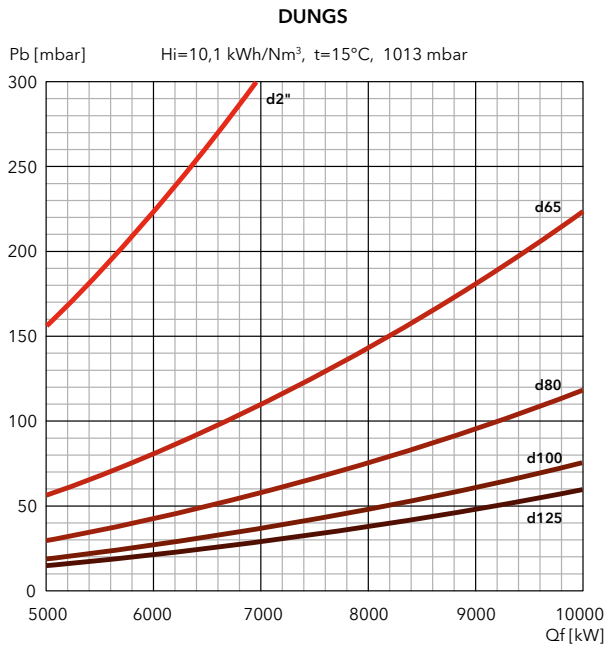

N9.10400 G-E

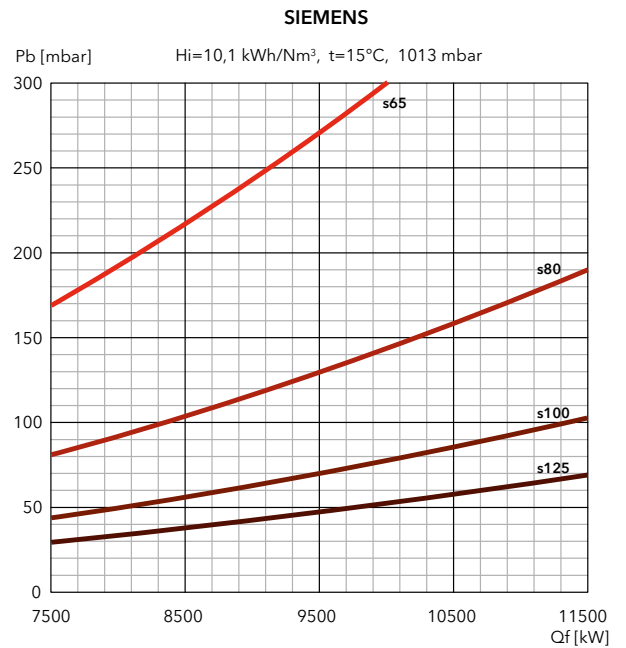
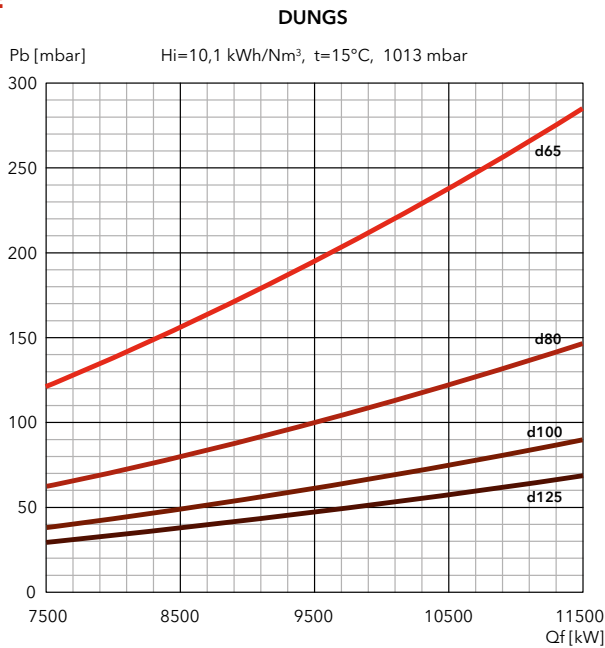

FILTERS

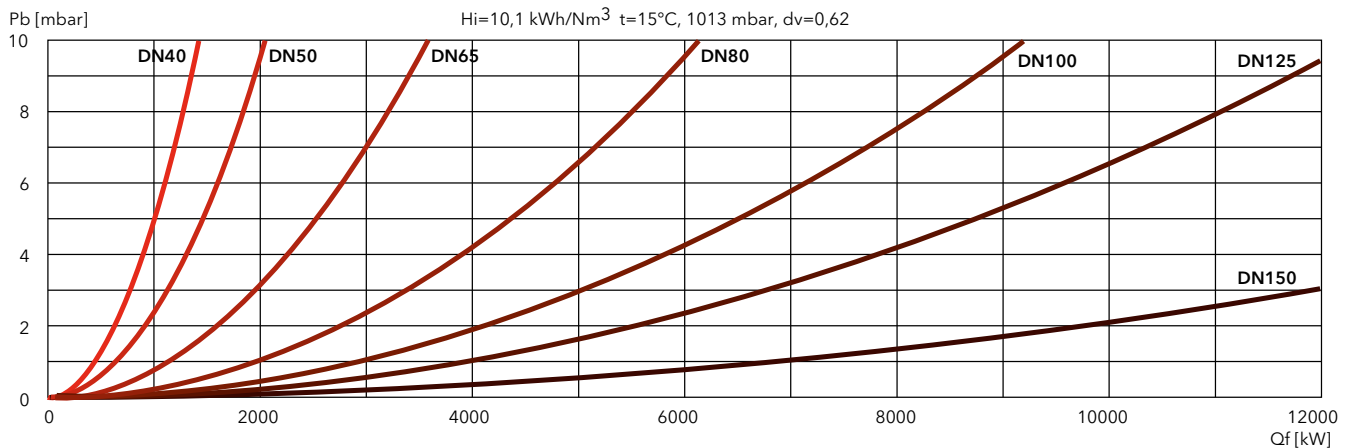

N6 GL-EF3 / N7 GL-EF3

280 ... 4500 kW

Two stage progressive/modulating electronic in gas and in light oil



- **Fuels:** natural gas, Hi = 6,99 ... 11,39 kWh/Nm³;
light oil, viscosity 6 mm²/s at 20°C, Hi = 11,86 kWh/kg
- **Emission class:** Low NOx class 3 (≤80 mg/kWh) according to EN676 in gas
Low NOx class 3 (≤120 mg/kWh) according to EN267 in light oil
- **Protection level:** IP 41

TECHNICAL DATA

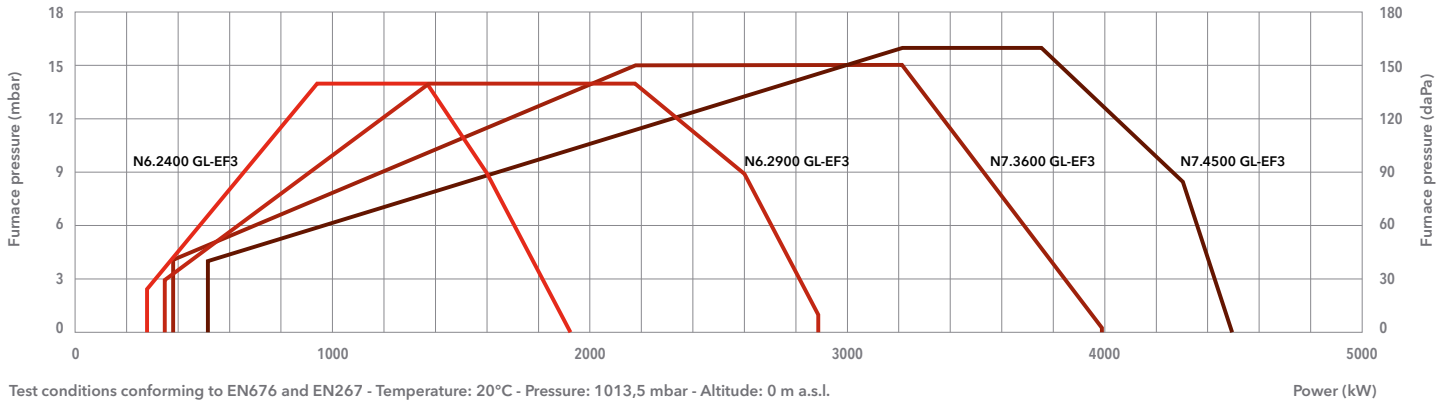

Test conditions conforming to EN676 and EN267 - Temperature: 20°C - Pressure: 1013,5 mbar - Altitude: 0 m a.s.l.

	N6.2400 GL-EF3	N6.2900 GL-EF3	N7.3600 GL-EF3	N7.4500 GL-EF3
Operating range gas	280 - 1920 kW	340 - 2890 kW	470 - 3980 kW	510 - 4500 kW
Operating range oil	360 - 1920 kW	740 - 2890 kW	680 - 3980 kW	740 - 4500 kW
Gas pressure	50 - 500 mbar (50 - 360 mbar for d452 and d453 gas train)		50 - 500 mbar (50 - 360 mbar for d452 and d453 gas train)	
Gas connection	DN65	DN65	DN65	DN65
Auxiliary voltage	1NPE AC 230 V - 50 Hz TN-S	1NPE AC 230 V - 50 Hz TN-S	1NPE AC 230 V - 50 Hz TN-S	1NPE AC 230 V - 50 Hz TN-S
Power supply	3PE AC 400 V - 50 Hz	3PE AC 400 V - 50 Hz	3PE AC 400 V - 50 Hz	3PE AC 400 V - 50 Hz
Control box / flame detector	BT300 / FFS08	BT300 / FFS08	BT300 / FFS08	BT300 / FFS08
Fan motor	50 Hz - 3 kW	50 Hz - 4 kW	50 Hz - 7,5 kW	50 Hz - 7,5 kW
Pump	SUNTEC TA3	SUNTEC TA3	SUNTEC TA4	SUNTEC TA4
Motor pump	50 Hz - 0,74 kW	50 Hz - 0,74 kW	50 Hz - 1,1 kW	50 Hz - 1,5 kW
Acoustic level	<71 dB(A)	<71 dB(A)	<76 dB(A)	<74 dB(A)
CE certificate	0085CL0215	0085CL0215	0085CL0215	0085CL0215
Complete burner codes	on request	on request	on request	on request

GAS TRAINS

DUNGS

Model	Code
GT-d452-1"1/2 (*)	3750510
GT-d453-2" (*)	3750511
GT-d454-65	3750512
GT-d455-80	3750513
GT-d456-100	3750514

SIEMENS

Model	Code
GT-s451-1"1/2	3750525
GT-s452-2"	3750526
GT-s453-65	3750527
GT-s454-80	3750528
GT-s455-100	3750529
GT-s456-125	3750530

FILTERS

Model	Code
FG-Rp1"1/2	3757199
FG-Rp2"	3757200
FG-DN65	3757198
FG-DN80	3757201
FG-DN100	3757195
FG-DN125	3757209

*: integrated filter

i **Pressure drops graphs:** see following pages
Dimensions of gas trains and gas filters: see page 310



DIMENSIONS (mm)

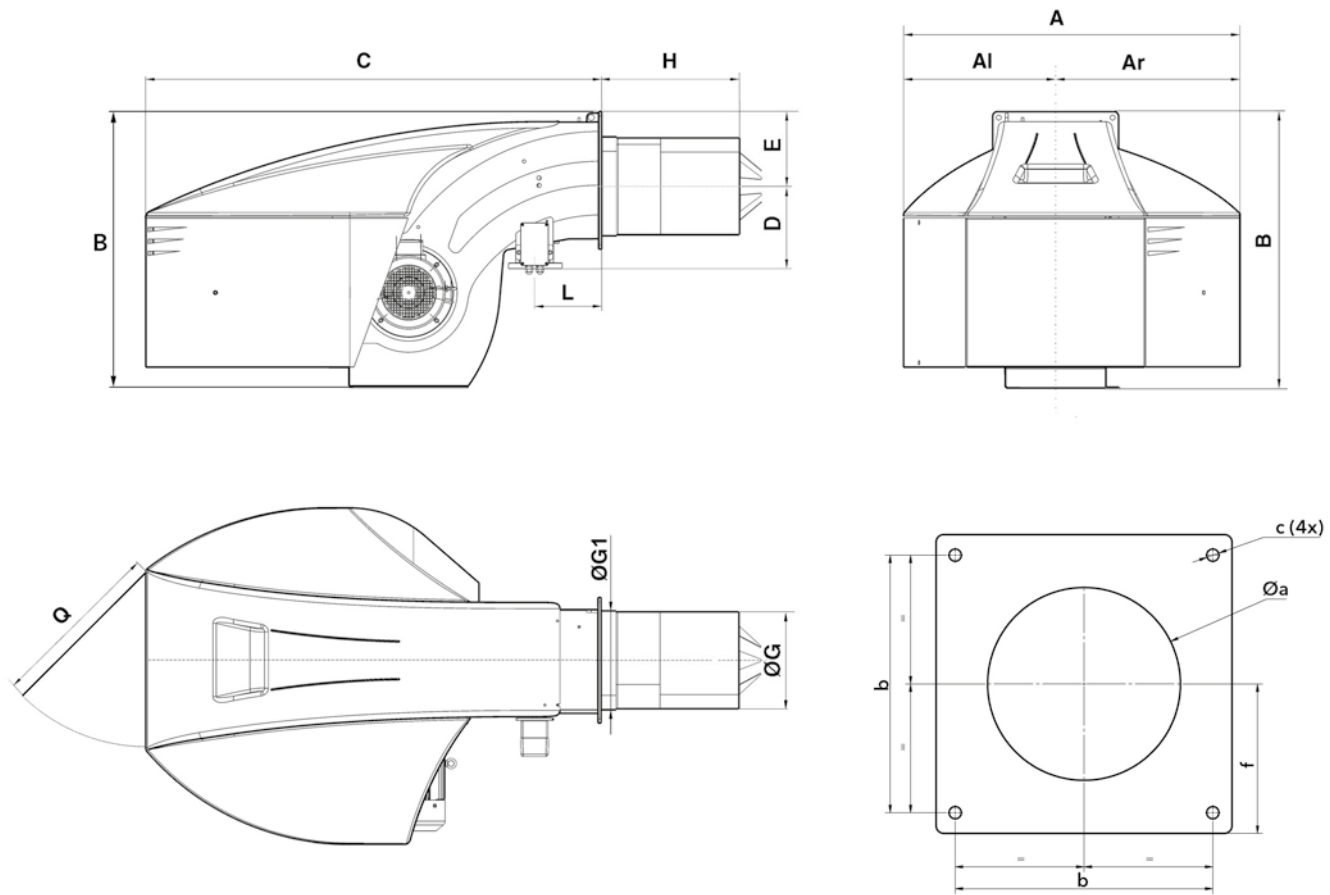

Model	A	Al	Ar	B	C	D	E	ØG	ØG1	H			L	Q	Øa	b	c	f
										KN	KM	KL						
N6.2400 GL-EF3	989	479	510	837	1361	245	225	227	270	400	520	640	215	600	300-340	340	M16	200
N6.2900 GL-EF3	989	479	510	837	1361	245	225	263,5	270	400	520	640	215	600	300-340	340	M16	200
N7.3600 GL-EF3	1128	510	618	961	1529	276	255	325	332	420	550	680	225	600	360-400	400	M16	235
N7.4500 GL-EF3	1128	510	618	961	1529	276	255	325	332	420	550	680	225	600	360-400	400	M16	235

PACKAGING

The burner is delivered on a pallet with:

- burner body with mounted combustion head
- gas train and filter
- boiler fixing accessories
- technical documentation

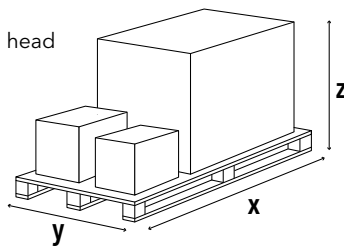

Model	Dimensions (mm)			Gross weight (kg)
	X	Y	Z	
N6.2400 GL-EF3	2300	1500	1573	360
N6.2900 GL-EF3	2300	1500	1573	360
N7.3600 GL-EF3	2300	1500	1573	450
N7.4500 GL-EF3	2300	1500	1573	450

N6 GL-EF3 / N7 GL-EF3

280 ... 4500 kW

Two stage progressive/modulating electronic in gas and in light oil

PRESSURE LOSS [BURNER HEAD + GAS TRAIN] (mbar)

N6.2400 GL-EF3

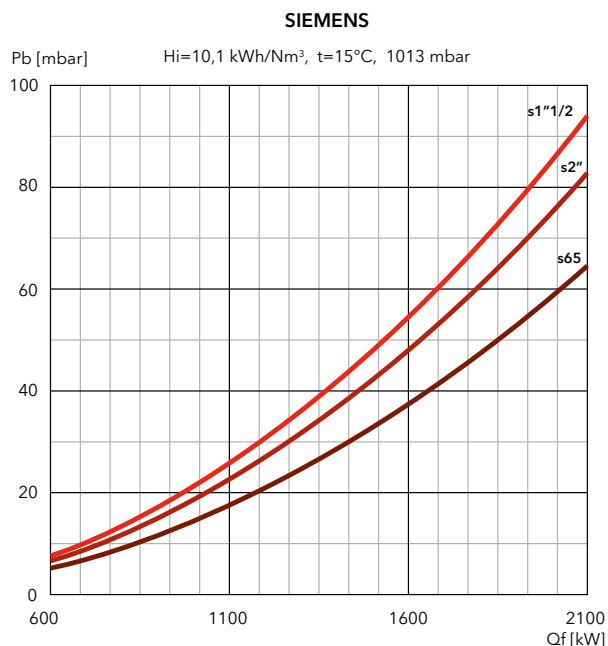
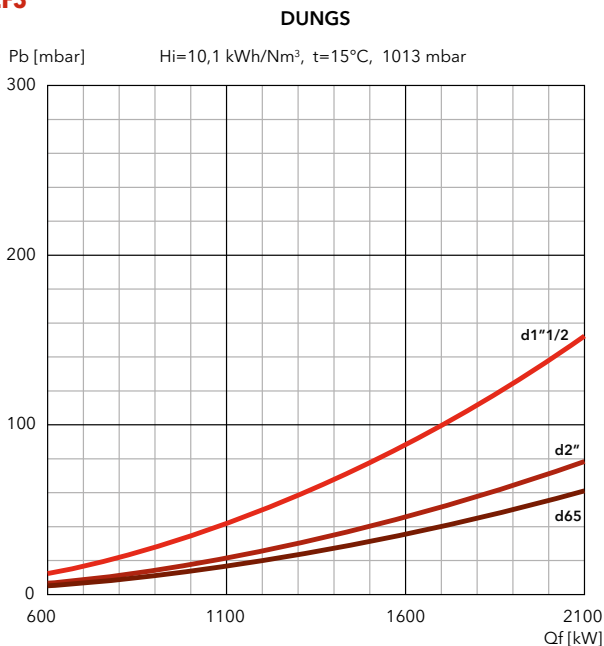

N6.2900 GL-EF3

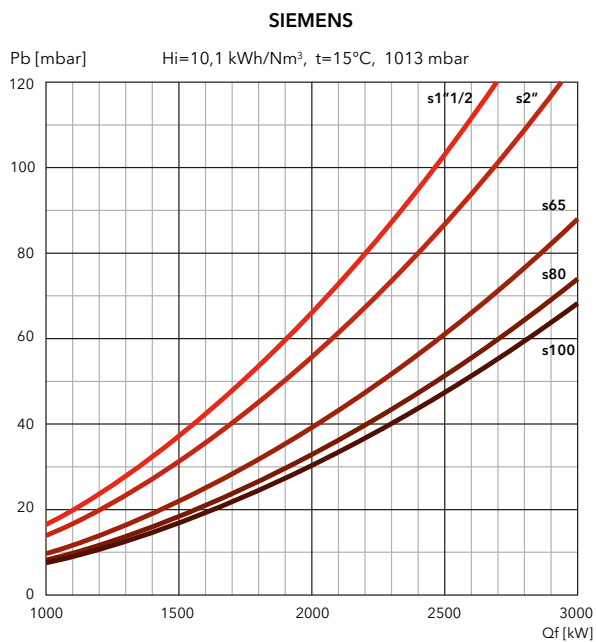
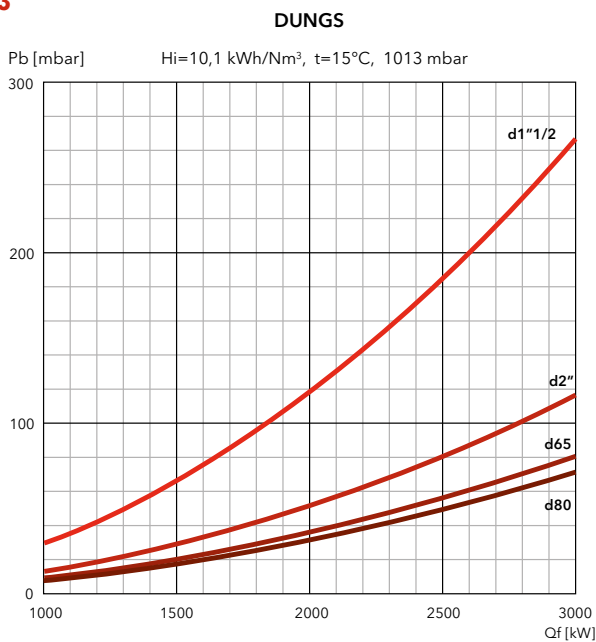

FILTERS

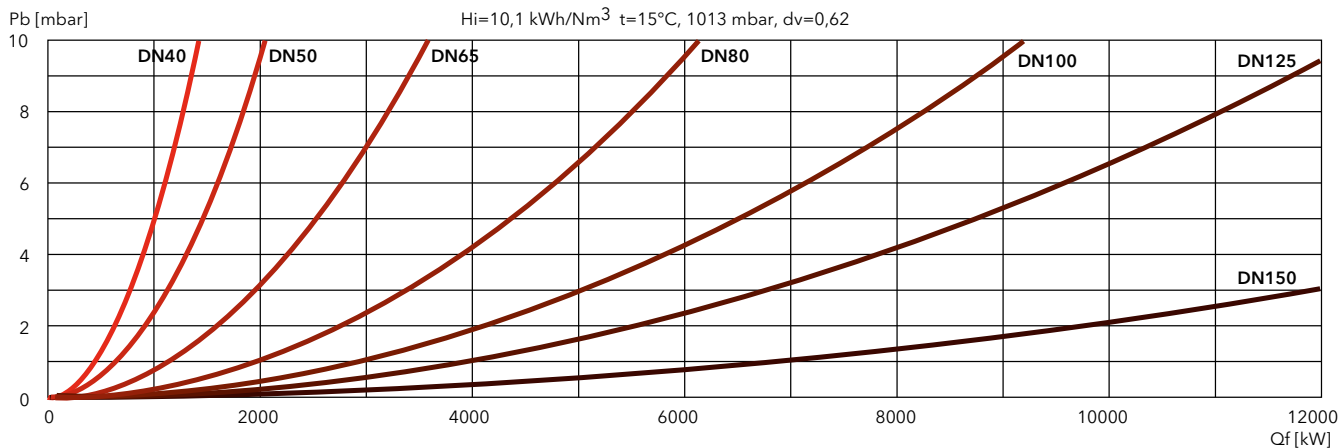



PRESSURE LOSS [BURNER HEAD + GAS TRAIN] (mbar)

N7.3600 GL-EF3

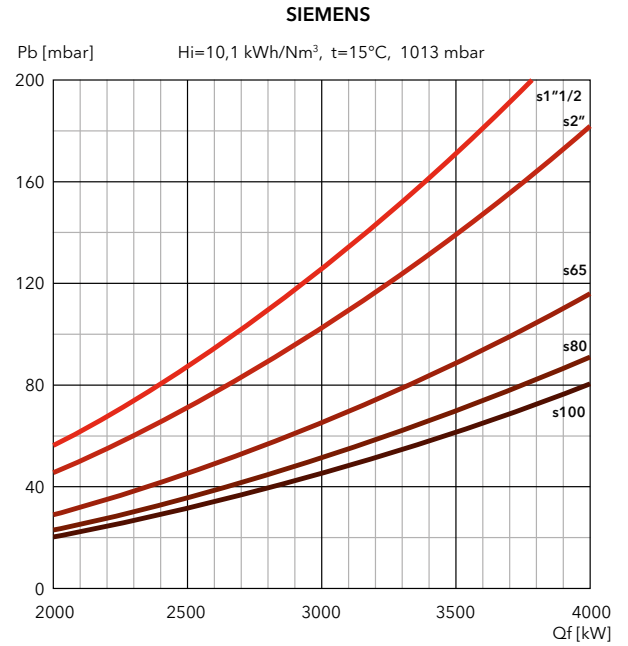
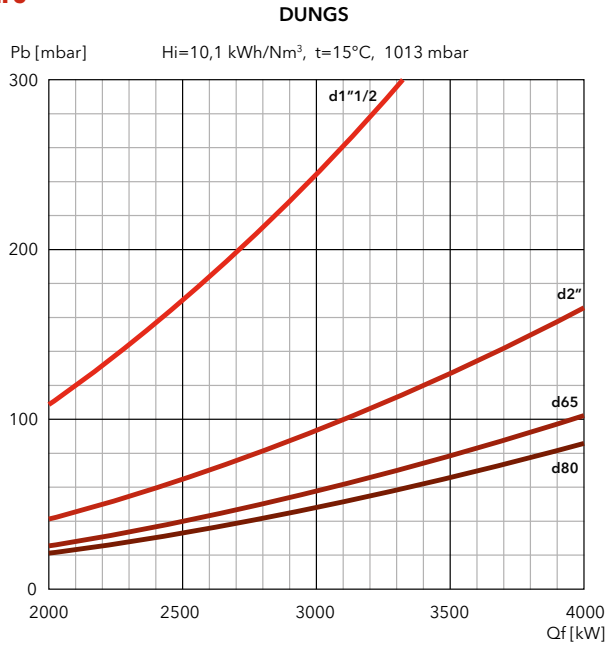

N7.4500 GL-EF3

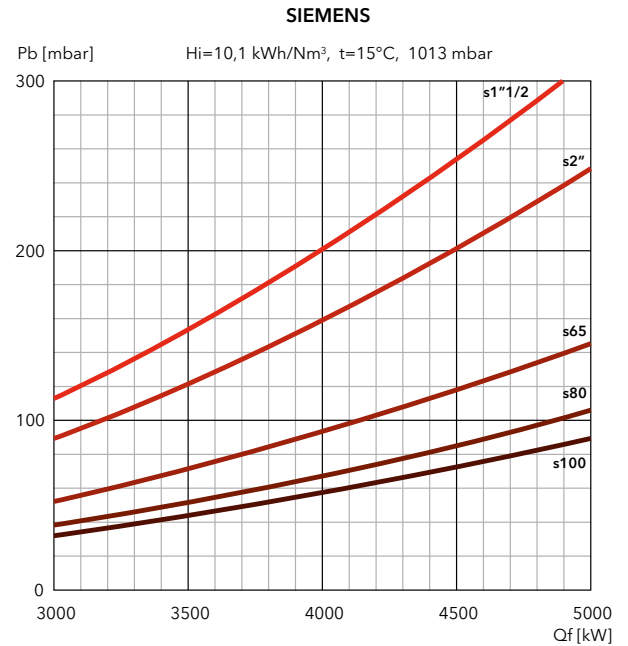
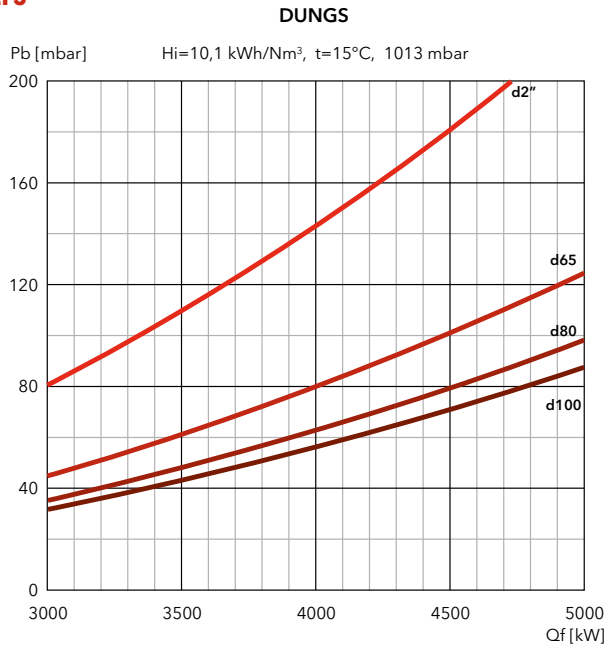

FILTERS

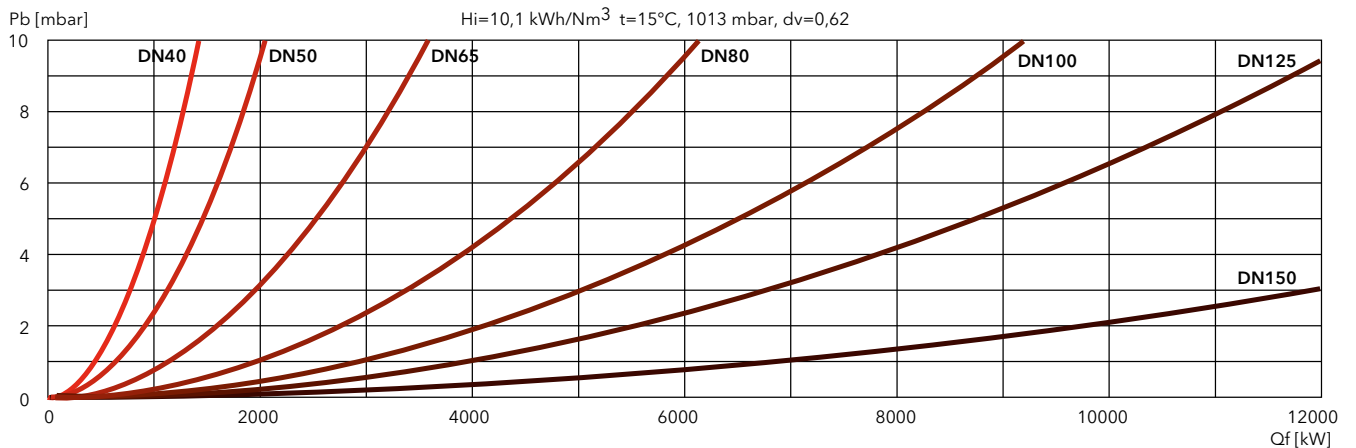

N8 GL-EF3 / N9 GL-EF3 / N9 GL-EUF

830 ... 9570 kW

Two stage progressive/modulating electronic in gas and in light oil



- **Fuels:** natural gas, Hi = 6,99 ... 11,39 kWh/Nm³;
light oil, viscosity 6 mm²/s at 20°C, Hi = 11,86 kWh/kg
- **Emission class:** Low NOx class 3 (≤80 mg/kWh) according to EN676 in gas
Low NOx class 3 (≤120 mg/kWh) according to EN267 in light oil
- **Protection level:** IP 41

TECHNICAL DATA

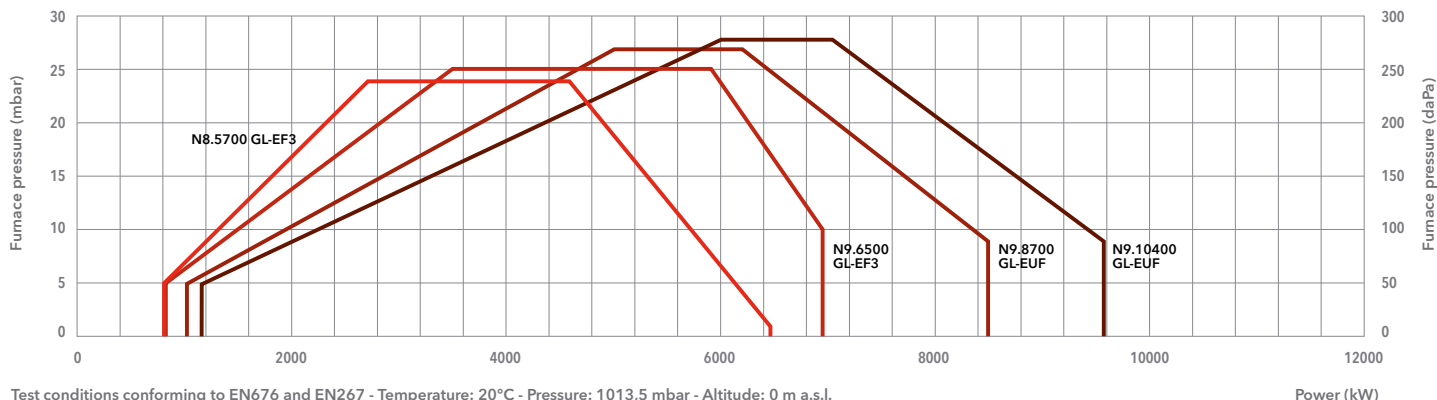

Test conditions conforming to EN676 and EN267 - Temperature: 20°C - Pressure: 1013,5 mbar - Altitude: 0 m a.s.l.

	N8.5700 GL-EF3	N9.6500 GL-EF3	N9.8700 GL-EUF	N9.10400 GL-EUF
Operating range gas	830 – 6450 kW	830 – 6950 kW	1040 – 8500 kW	1160 – 9570 kW
Operating range oil	1030 – 6450 kW	1030 – 6600 kW	1800 – 8500 kW	2550 – 9570 kW
Gas pressure	100 – 500 mbar (100 – 360 mbar for d457 gas train)		100 – 500 mbar (100 – 360 mbar for d457 gas train)	
Gas connection	DN100	DN100	DN100	DN100
Auxiliary voltage	1NPE AC 230 V – 50 Hz TN-S	1NPE AC 230 V – 50 Hz TN-S	1NPE AC 230 V – 50 Hz TN-S	1NPE AC 230 V – 50 Hz TN-S
Power supply	3PE AC 400 V – 50 Hz	3PE AC 400 V – 50 Hz	3PE AC 400 V – 50 Hz	3PE AC 400 V – 50 Hz
Control box / flame detector	BT300 / FFS08	BT300 / FFS08	BT300 / FFS08	BT300 / FFS08
Fan motor	50 Hz – 15 kW	50 Hz – 22 kW	50 Hz – 18,5 kW	50 Hz – 22 kW
Pump	SMG1630 – 1700 l/h	SMG1630 – 1700 l/h	SMG1630 – 1700 l/h	SMG1631 – 2200 l/h
Motor pump	50 Hz – 3 kW	50 Hz – 3 kW	50 Hz – 3 kW	50 Hz – 4 kW
Acoustic level	<80 dB(A)	<83 dB(A)	<81 dB(A)	<81,7 dB(A)
CE certificate	0085CL0215	0085CL0215	0085CL0215	0085CL0215
Complete burner codes	on request	on request	on request	on request

GAS TRAINS

DUNGS

Model	Code
GT-d457-2" (*)	3750515
GT-d458-65	3750516
GT-d459-80	3750517
GT-d460-100	3750518

SIEMENS

Model	Code
GT-s457-2"	3750537
GT-s458-65	3750538
GT-s459-80	3750539
GT-s460-100	3750540
GT-s461-125	3750541

FILTERS

Model	Code
FG-Rp2"	3757200
FG-DN65	3757198
FG-DN80	3757201
FG-DN100	3757195
FG-DN125	3757209

*: integrated filter

i **Pressure drops graphs:** see following pages
Dimensions of gas trains and gas filters: see page 311



DIMENSIONS (mm)

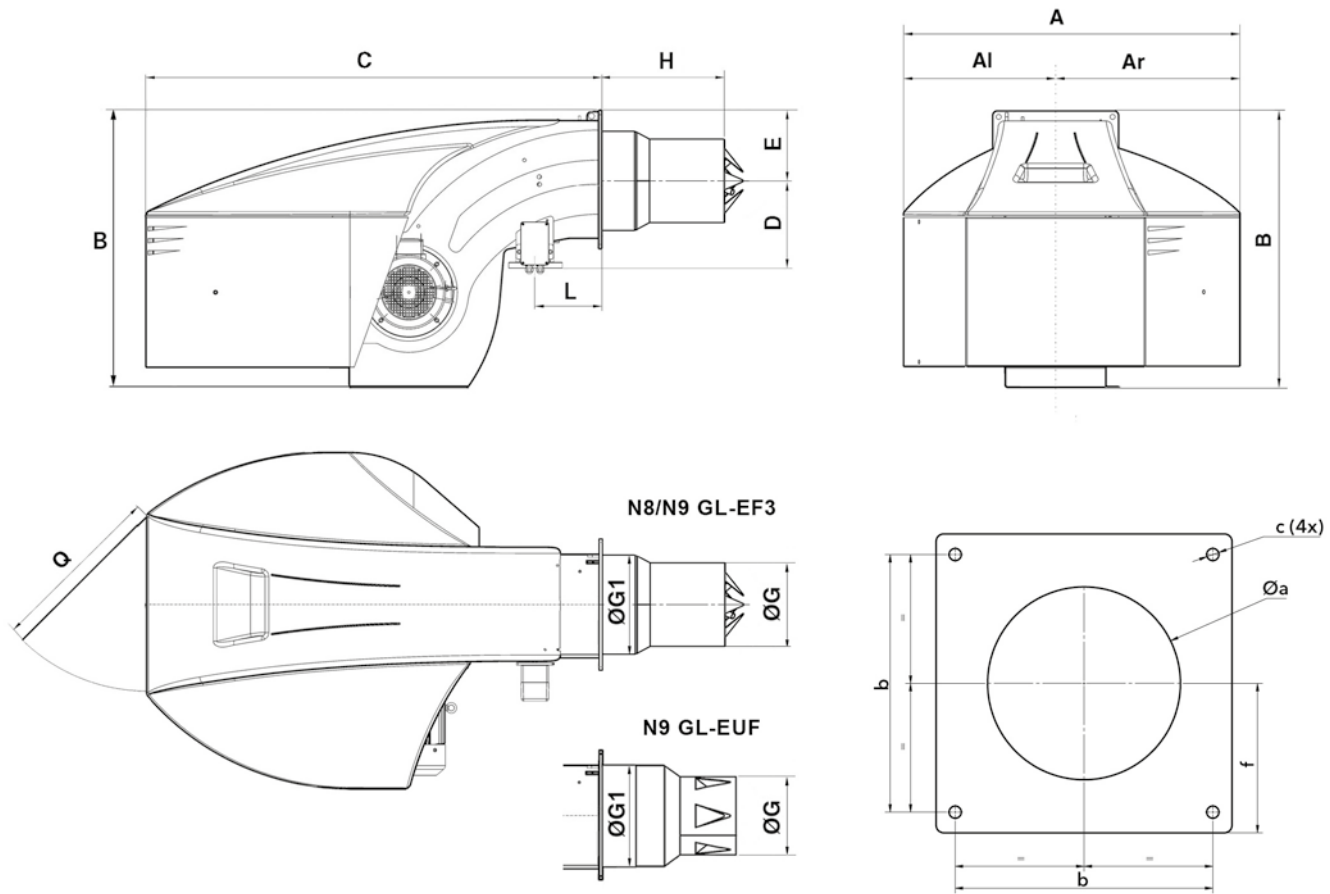

Model	A	AI	Ar	B	C	D	E	ØG	ØG1	H			L	Q	Øa	b	c	f
										KN	KM	KL						
N8.5700 GL-EF3	1414	669	745	1231	1930	391	293	369	376	528	668	808	230	800	380-410	505	M20	293
N9.6500 GL-EF3	1414	669	745	1291	1930	416	293	369	438,5	543	693	843	230	800	445-480	505	M20	293
N9.8700 GL-EUF	1414	669	745	1291	1930	416	293	325	438,5	575	725	875	230	800	445-480	505	M20	293
N9.10400 GL-EUF	1414	669	745	1291	1930	416	293	335	438,5	575	725	875	230	800	445-480	505	M20	293

PACKAGING

The burner is delivered on a pallet with:

- burner body with mounted combustion head
- gas train and filter
- boiler fixing accessories
- technical documentation

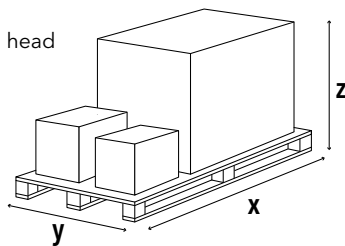

Model	Dimensions (mm)			Gross weight (kg)
	X	Y	Z	
N8.5700 GL-EF3	2900	1600	1573	700
N9.6500 GL-EF3	2900	1600	1573	760
N9.8700 GL-EUF	2900	1600	1573	760
N9.10400 GL-EUF	2900	1600	1573	760

N8 GL-EF3 / N9 GL-EF3 / N9 GL-EUF

830 ... 9570 kW

Two stage progressive/modulating electronic in gas and in light oil

PRESSURE LOSS [BURNER HEAD + GAS TRAIN] (mbar)

N8.5700 GL-EF3

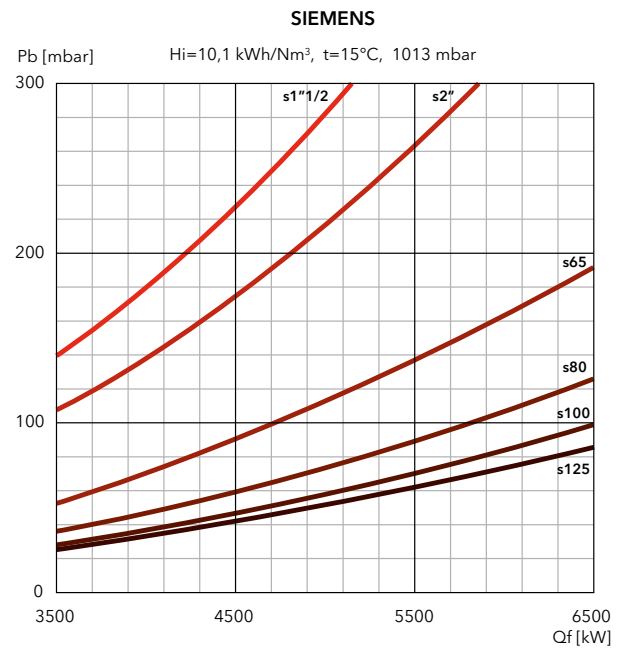
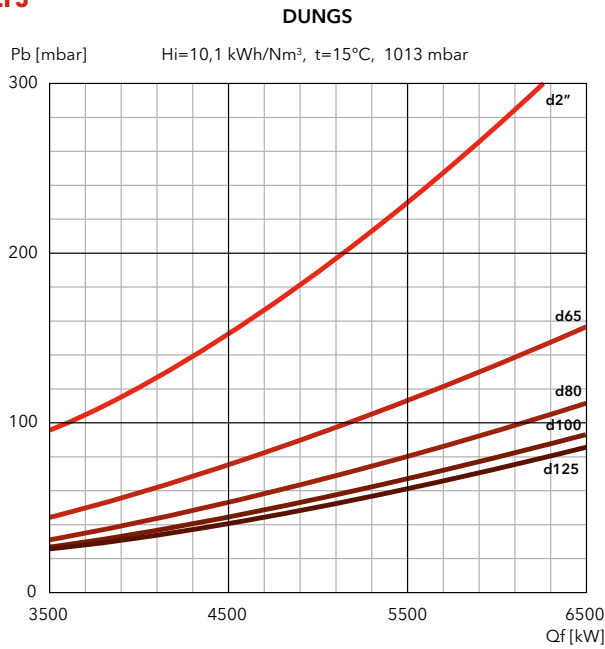

N9.6500 GL-EF3

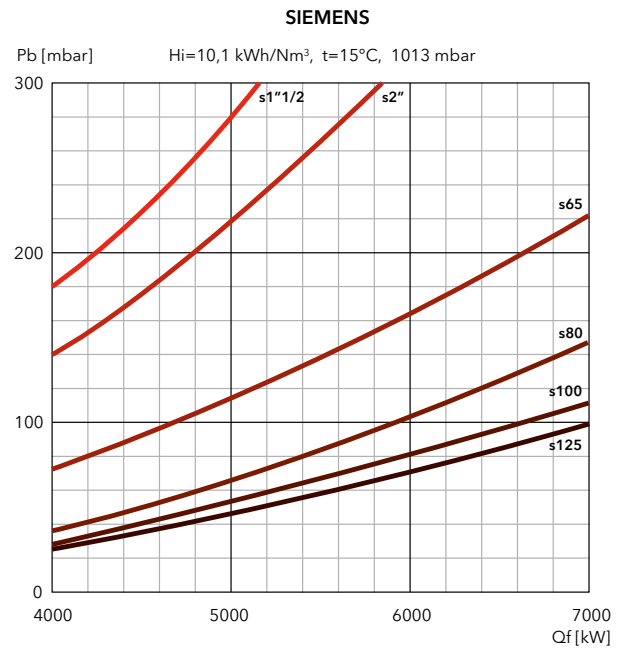
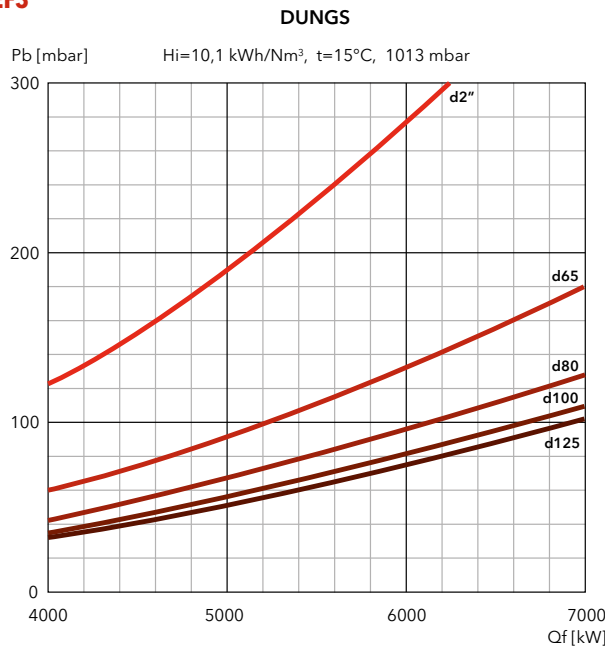

FILTERS

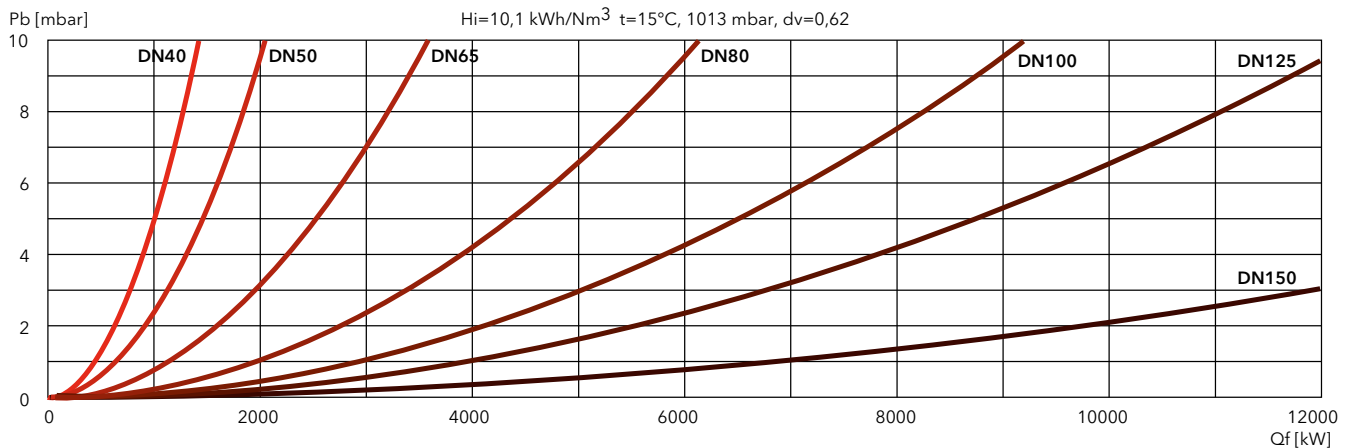



PRESSURE LOSS [BURNER HEAD + GAS TRAIN] (mbar)

N9.8700 GL-EUF

DUNGS

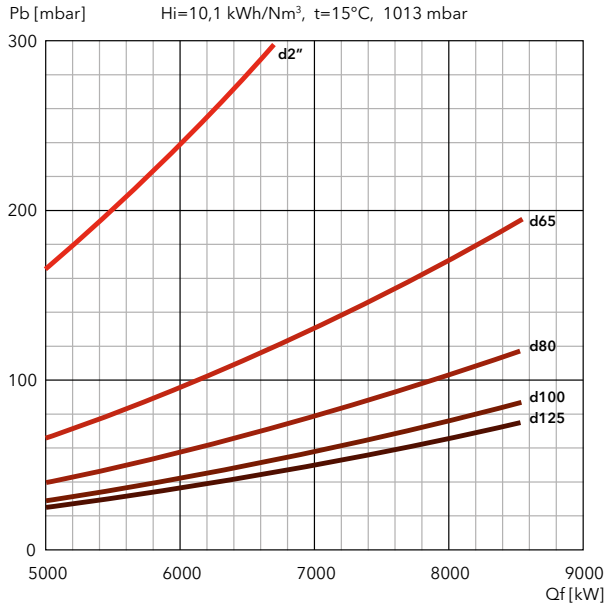

SIEMENS

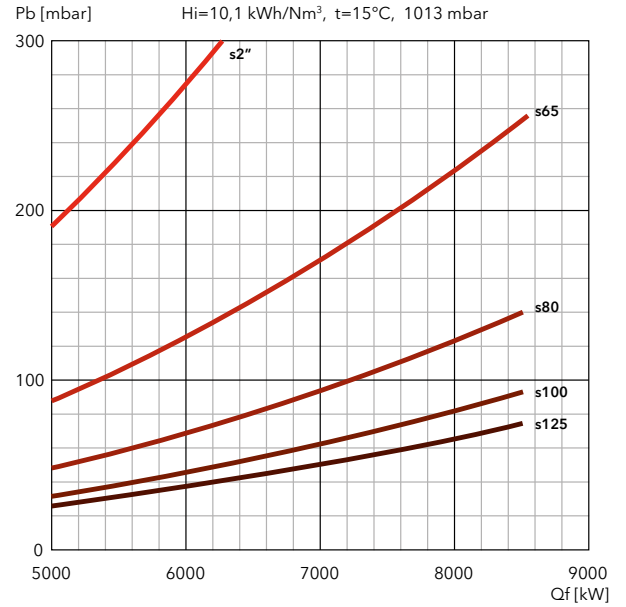

N9.10400 GL-EUF

DUNGS

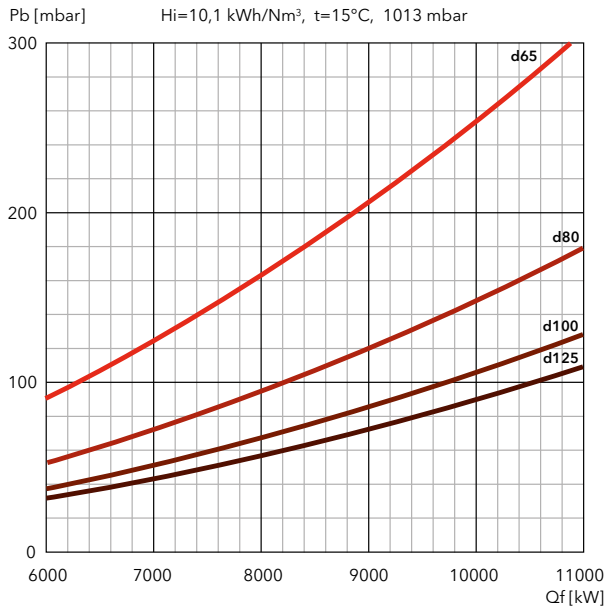

SIEMENS

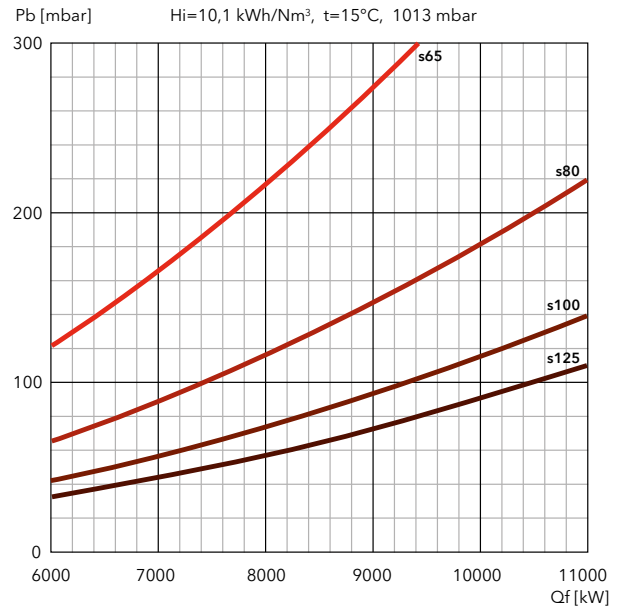

FILTERS

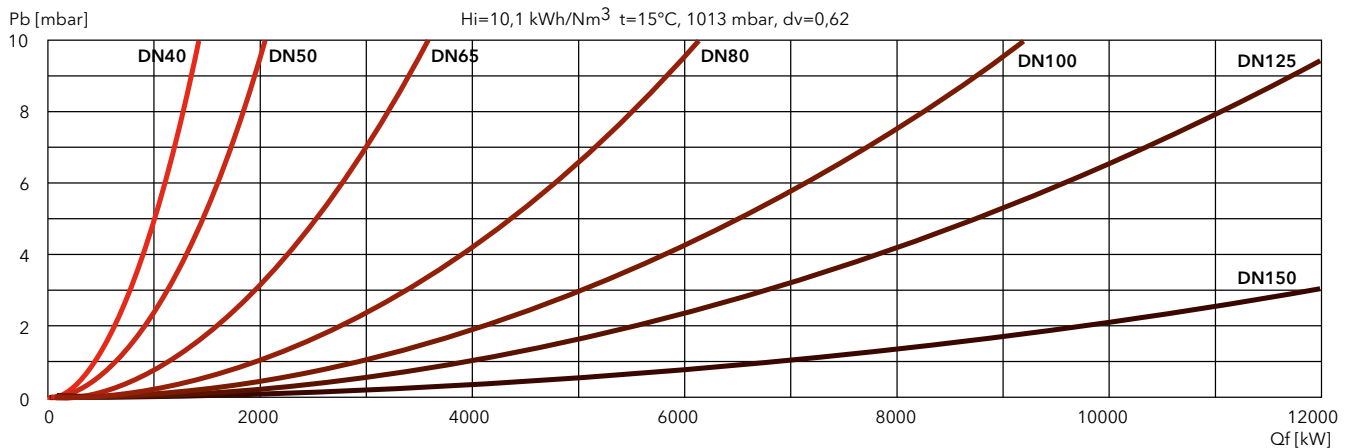

N6 GL-E / N7 GL-E

250 ... 4750 kW

Two stage progressive/modulating electronic in gas and in light oil



- **Fuels:** natural gas, Hi = 6,99 ... 11,39 kWh/Nm³;
light oil, viscosity 6 mm²/s at 20°C, Hi = 11,86 kWh/kg
- **Emission class:** Low NOx class 2 (≤120 mg/kWh) according to EN676 in gas
Low NOx class 2 (≤185 mg/kWh) according to EN267 in light oil
- **Protection level:** IP 41

TECHNICAL DATA

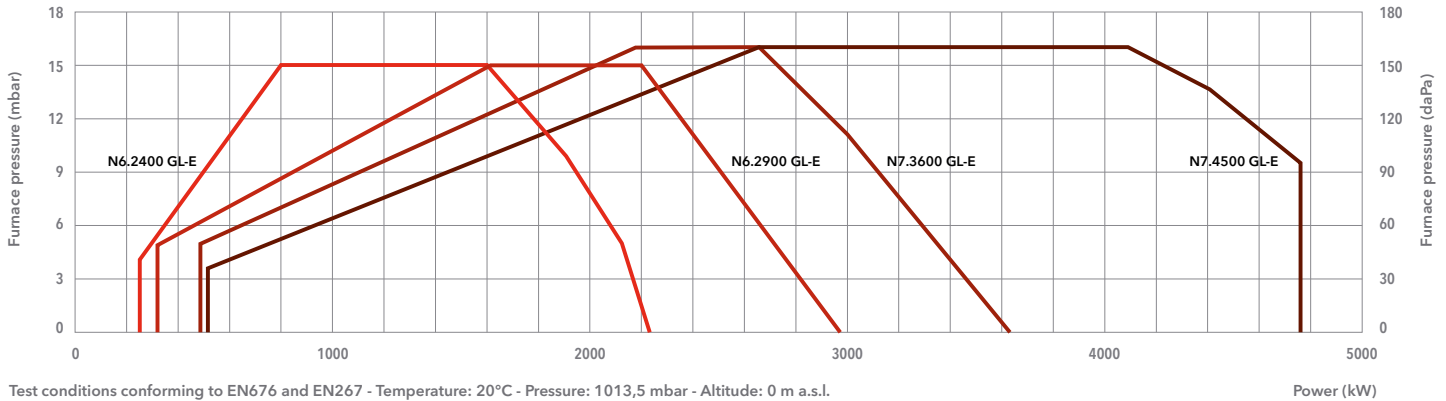

Test conditions conforming to EN676 and EN267 - Temperature: 20°C - Pressure: 1013,5 mbar - Altitude: 0 m a.s.l.

	N6.2400 GL-E	N6.2900 GL-E	N7.3600 GL-E	N7.4500 GL-E
Operating range gas	250 - 2230 kW	320 - 2970 kW	490 - 3650 kW	510 - 4750 kW
Operating range oil	510 - 2030 kW	650 - 2970 kW	900 - 3650 kW	1300 - 4750 kW
Gas pressure	50 - 500 mbar (50 - 360 mbar for d452 and d453 gas train)		50 - 500 mbar (50 - 360 mbar for d452 and d453 gas train)	
Gas connection	DN65	DN65	DN65	DN65
Auxiliary voltage	1NPE AC 230 V - 50 Hz TN-S	1NPE AC 230 V - 50 Hz TN-S	1NPE AC 230 V - 50 Hz TN-S	1NPE AC 230 V - 50 Hz TN-S
Power supply	3PE AC 400 V - 50 Hz	3PE AC 400 V - 50 Hz	3PE AC 400 V - 50 Hz	3PE AC 400 V - 50 Hz
Control box / flame detector	BT300 / QRA2	BT300 / QRA2	BT300 / QRA2	BT300 / QRA2
Fan motor	50 Hz - 3 kW	50 Hz - 4 kW	50 Hz - 5,5 kW	50 Hz - 7,5 kW
Pump	SUNTEC TA3	SUNTEC TA3	SUNTEC TA4	SUNTEC TA4
Motor pump	50 Hz - 0,74 kW	50 Hz - 0,74 kW	50 Hz - 1,1 kW	50 Hz - 1,5 kW
Acoustic level	<70 dB(A)	<71 dB(A)	<74 dB(A)	<74 dB(A)
CE certificate	0085CL0215	0085CL0215	0085CL0215	0085CL0215
Complete burner codes	on request	on request	on request	on request

GAS TRAINS

DUNGS

Model	Code
GT-d452-1"1/2 (*)	3750510
GT-d453-2" (*)	3750511
GT-d454-65	3750512
GT-d455-80	3750513
GT-d456-100	3750514

SIEMENS

Model	Code
GT-s451-1"1/2	3750525
GT-s452-2"	3750526
GT-s453-65	3750527
GT-s454-80	3750528
GT-s455-100	3750529
GT-s456-125	3750530

FILTERS

Model	Code
FG-Rp1"1/2	3757199
FG-Rp2"	3757200
FG-DN65	3757198
FG-DN80	3757201
FG-DN100	3757195
FG-DN125	3757209

*: integrated filter

i Pressure drops graphs: see following pages
Dimensions of gas trains and gas filters: see page 310



DIMENSIONS (mm)

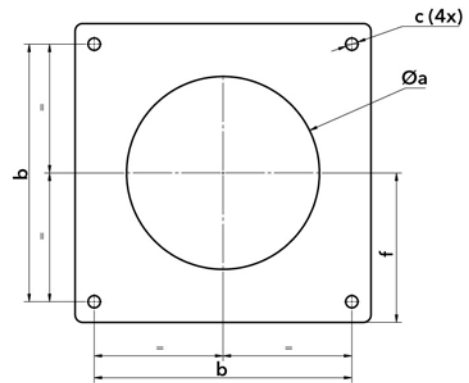
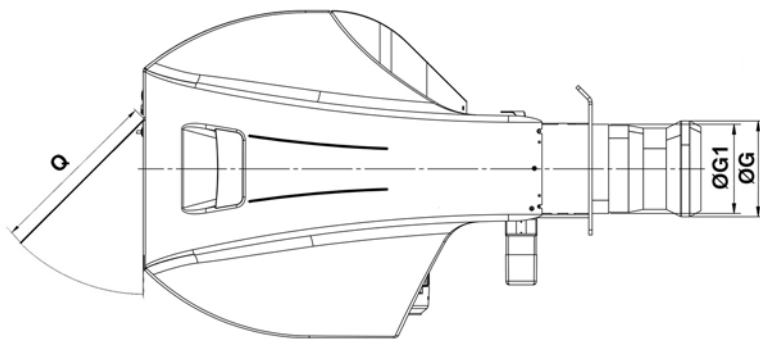
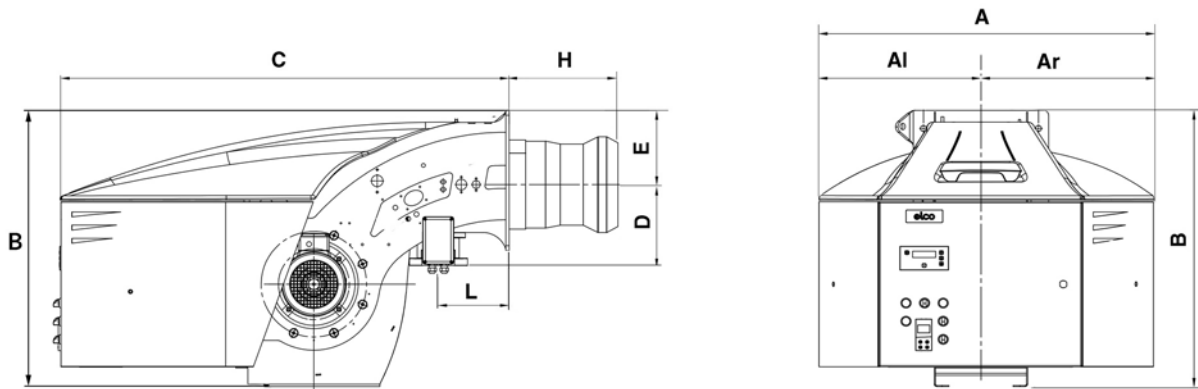

Model	A	Al	Ar	B	C	D	E	ØG	ØG1	H			L	Q	Øa	b	c	f
										KN	KM	KL						
N6.2400 GL-E	989	479	510	837	1369	245	225	290	270	330	450	570	215	600	300-340	340	M16	200
N6.2900 GL-E	989	479	510	837	1369	245	225	310	270	330	450	570	215	600	320-340	340	M16	200
N7.3600 GL-E	1128	510	618	961	1529	276	255	340	332	375	505	635	225	600	350-400	400	M16	235
N7.4500 GL-E	1128	510	618	961	1537	276	255	370	332	375	505	635	225	600	380-400	400	M16	235

PACKAGING

The burner is delivered on a pallet with:

- burner body with mounted combustion head
- gas train and filter
- boiler fixing accessories
- technical documentation

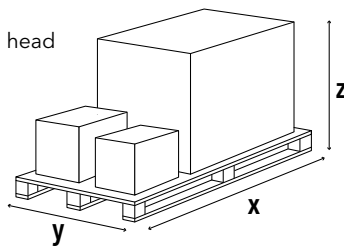

Model	Dimensions (mm)			Gross weight (kg)
	X	Y	Z	
N6.2400 GL-E	2300	1500	1573	360
N6.2900 GL-E	2300	1500	1573	360
N7.3600 GL-E	2300	1500	1573	450
N7.4500 GL-E	2300	1500	1573	450

N6 GL-E / N7 GL-E

250 ... 4750 kW

Two stage progressive/modulating electronic in gas and in light oil

PRESSURE LOSS [BURNER HEAD + GAS TRAIN] (mbar)

N6.2400 GL-E

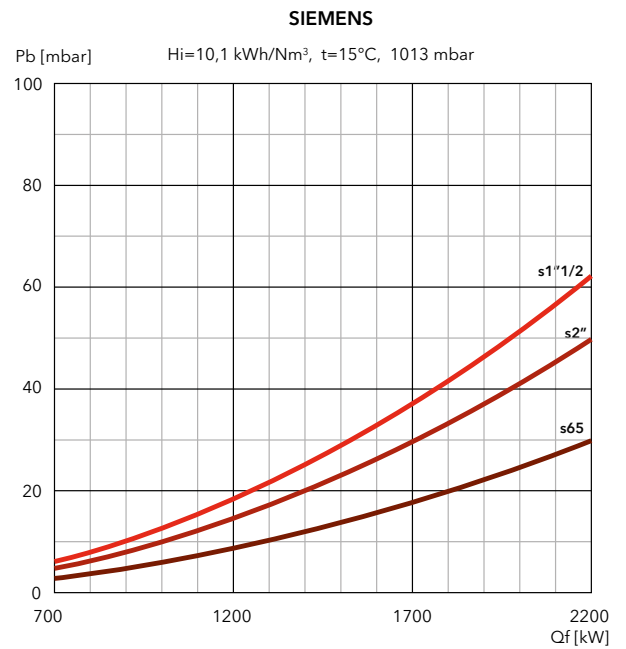
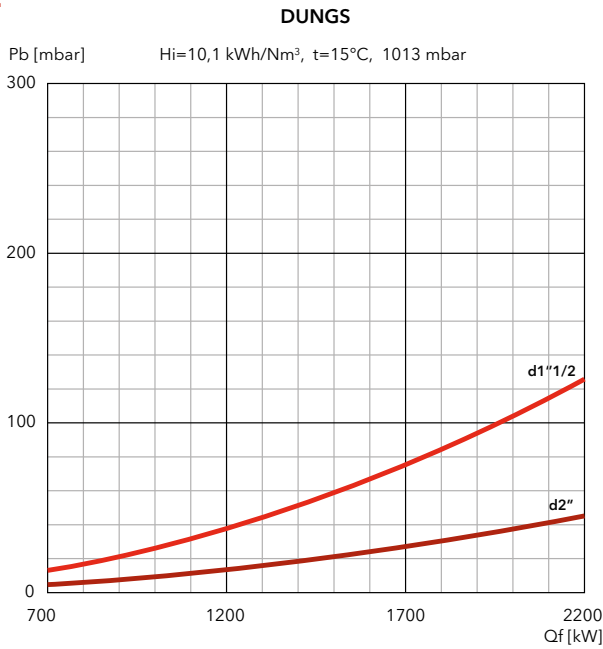

N6.2900 GL-E

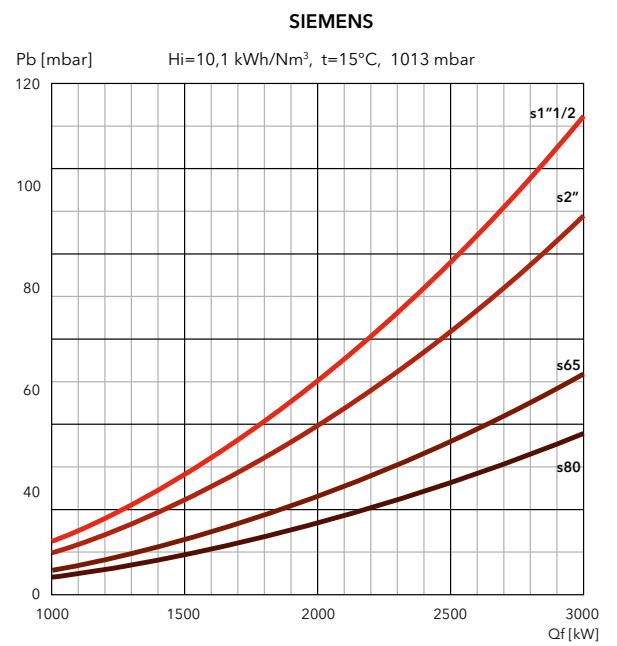
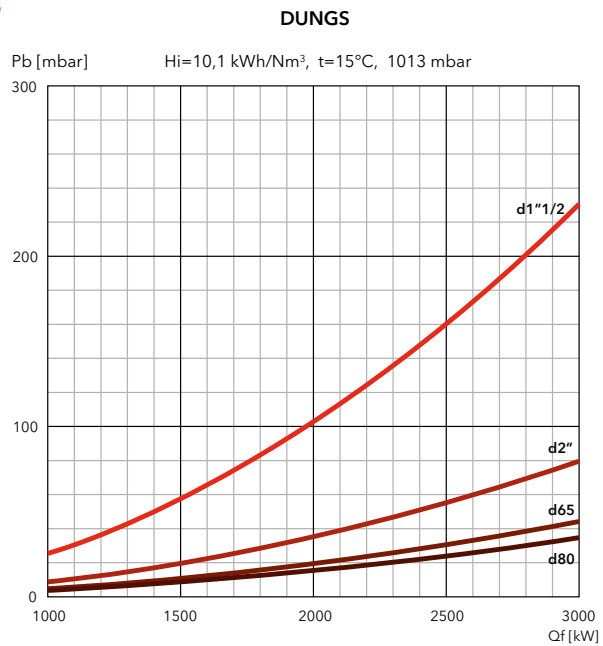

FILTERS

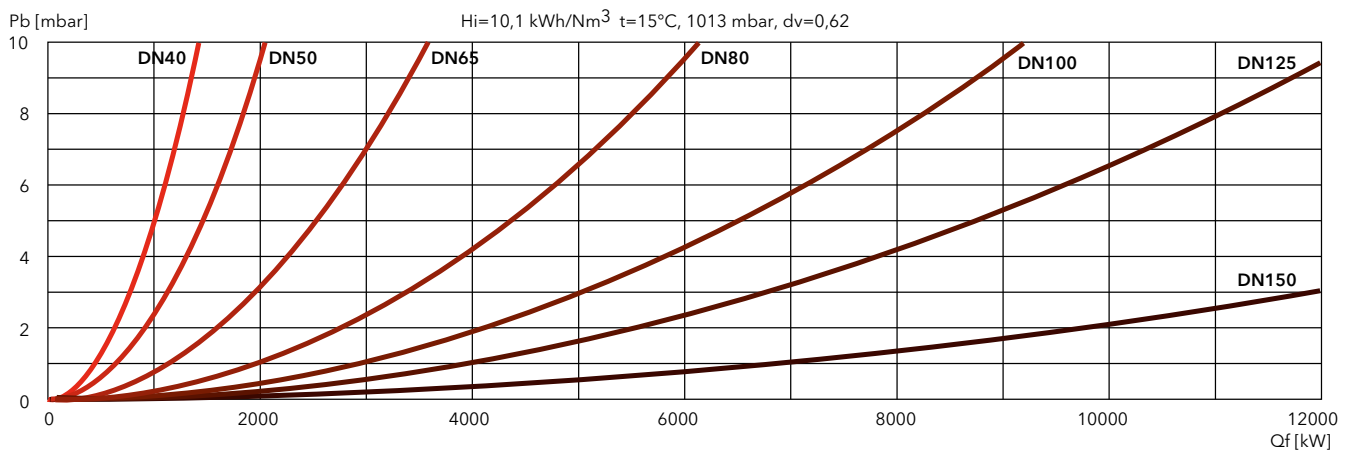



PRESSURE LOSS [BURNER HEAD + GAS TRAIN] (mbar)

N7.3600 GL-E

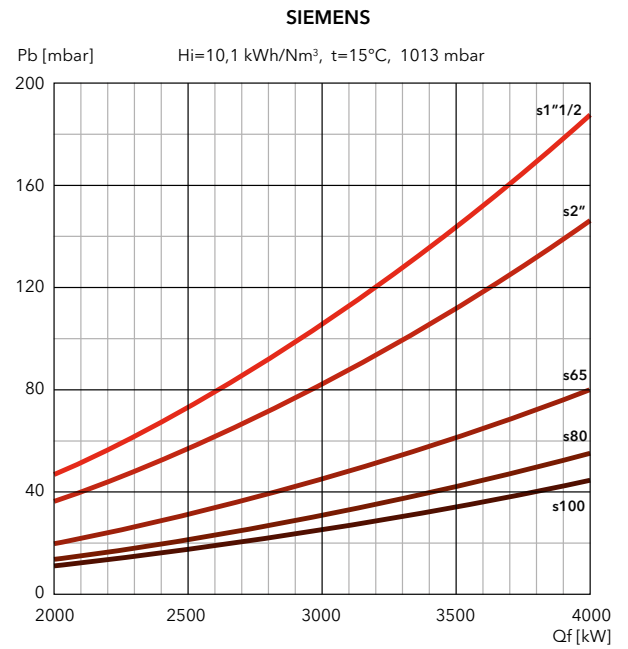
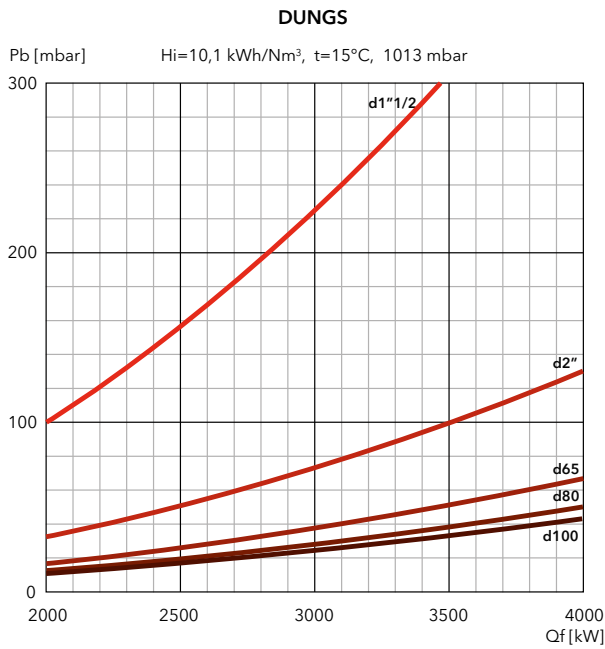

N7.4500 GL-E

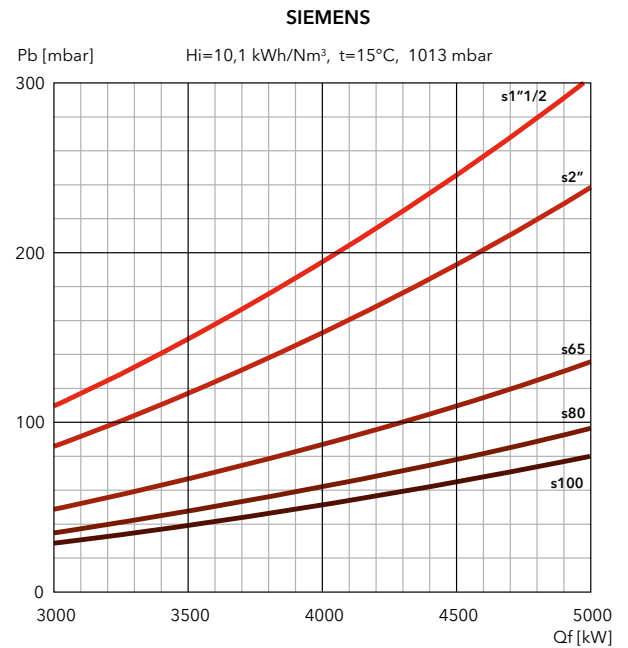
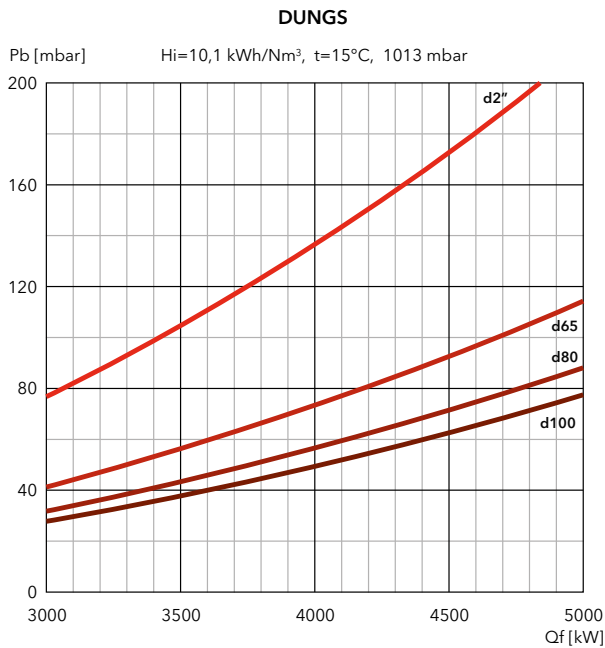

FILTERS

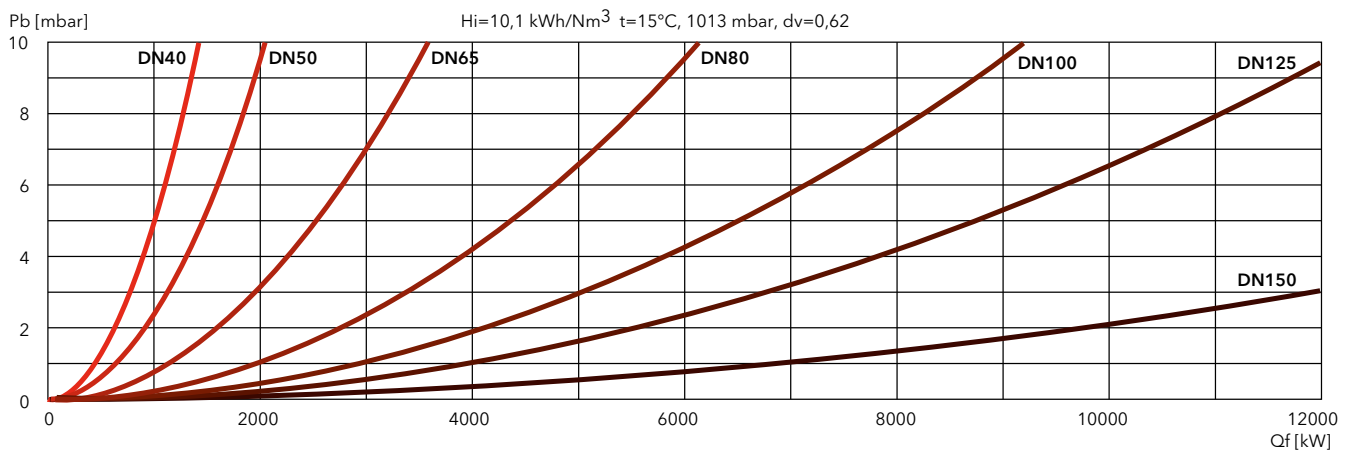

N8 GL-E / N9 GL-E

800 ... 10620 kW

Two stage progressive/modulating electronic in gas and in light oil



- **Fuels:** natural gas, Hi = 6,99 ... 11,39 kWh/Nm³;
light oil, viscosity 6 mm²/s at 20°C, Hi = 11,86 kWh/kg
- **Emission class:** Low NOx class 2 (≤120 mg/kWh) according to EN676 in gas
Low NOx class 2 (≤185 mg/kWh) according to EN267 in light oil
- **Protection level:** IP 41

TECHNICAL DATA

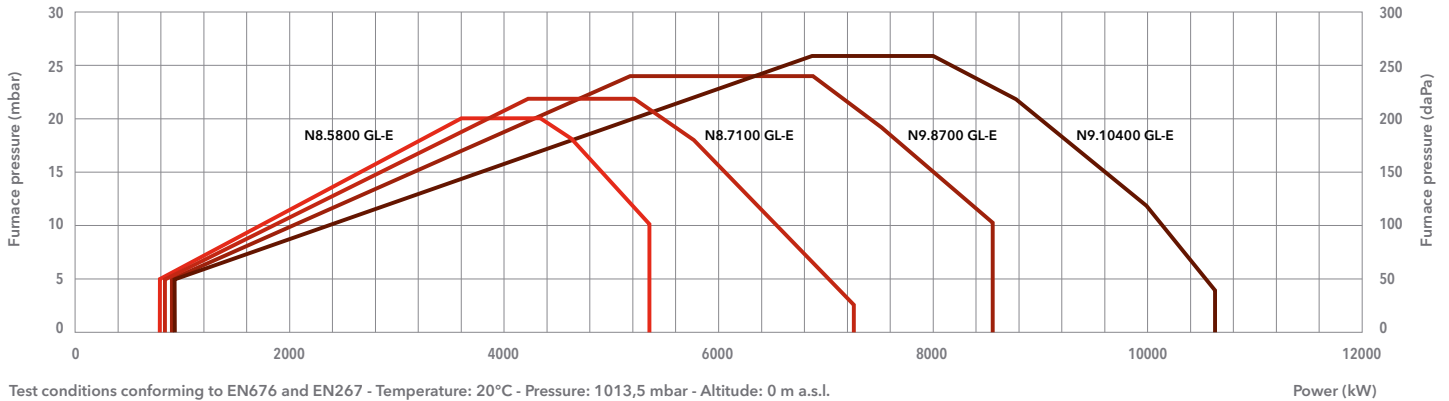

Test conditions conforming to EN676 and EN267 - Temperature: 20°C - Pressure: 1013,5 mbar - Altitude: 0 m a.s.l.

	N8.5800 GL-E	N8.7100 GL-E	N9.8700 GL-E	N9.10400 GL-E
Operating range gas	800 - 5350 kW	820 - 7340 kW	880 - 8530 kW	910 - 10620 kW
Operating range oil	1210 - 5350 kW	1470 - 7340 kW	2400 - 8530 kW	2820 - 10620 kW
Gas pressure	100 - 500 mbar (100 - 360 mbar for d457 gas train)		100 - 500 mbar (100 - 360 mbar for d457 gas train)	
Gas connection	DN100	DN100	DN100	DN100
Auxiliary voltage	1NPE AC 230 V - 50 Hz TN-S	1NPE AC 230 V - 50 Hz TN-S	1NPE AC 230 V - 50 Hz TN-S	1NPE AC 230 V - 50 Hz TN-S
Power supply	3PE AC 400 V - 50 Hz	3PE AC 400 V - 50 Hz	3PE AC 400 V - 50 Hz	3PE AC 400 V - 50 Hz
Control box / flame detector	BT300 / QRA2	BT300 / QRA2	BT300 / QRA2	BT300 / QRA2
Fan motor	50 Hz - 11 kW	50 Hz - 15 kW	50 Hz - 18,5 kW	50 Hz - 22 kW
Pump	SMG1630 - 1700 l/h	SMG1630 - 1700 l/h	SMG1630 - 1700 l/h	SMG1631 - 2200 l/h
Motor pump	50 Hz - 3 kW	50 Hz - 3 kW	50 Hz - 3 kW	50 Hz - 4 kW
Acoustic level	<77,4 dB(A)	<79,5 dB(A)	<81 dB(A)	<81,7 dB(A)
CE certificate	0085CL0215	0085CL0215	0085CL0215	0085CL0215
Complete burner codes	on request	on request	on request	on request

GAS TRAINS

DUNGS

Model	Code
GT-d457-2" (*)	3750515
GT-d458-65	3750516
GT-d459-80	3750517
GT-d460-100	3750518
GT-d125	on request

SIEMENS

Model	Code
GT-s456-1"1/2	3750536
GT-s457-2"	3750537
GT-s458-65	3750538
GT-s459-80	3750539
GT-s460-100	3750540
GT-s461-125	3750541

FILTERS

Model	Code
FG-Rp1"1/2	3757199
FG-Rp2"	3757200
FG-DN65	3757198
FG-DN80	3757201
FG-DN100	3757195
FG-DN125	3757209

*: integrated filter

i **Pressure drops graphs:** see following pages
Dimensions of gas trains and gas filters: see page 311



DIMENSIONS (mm)

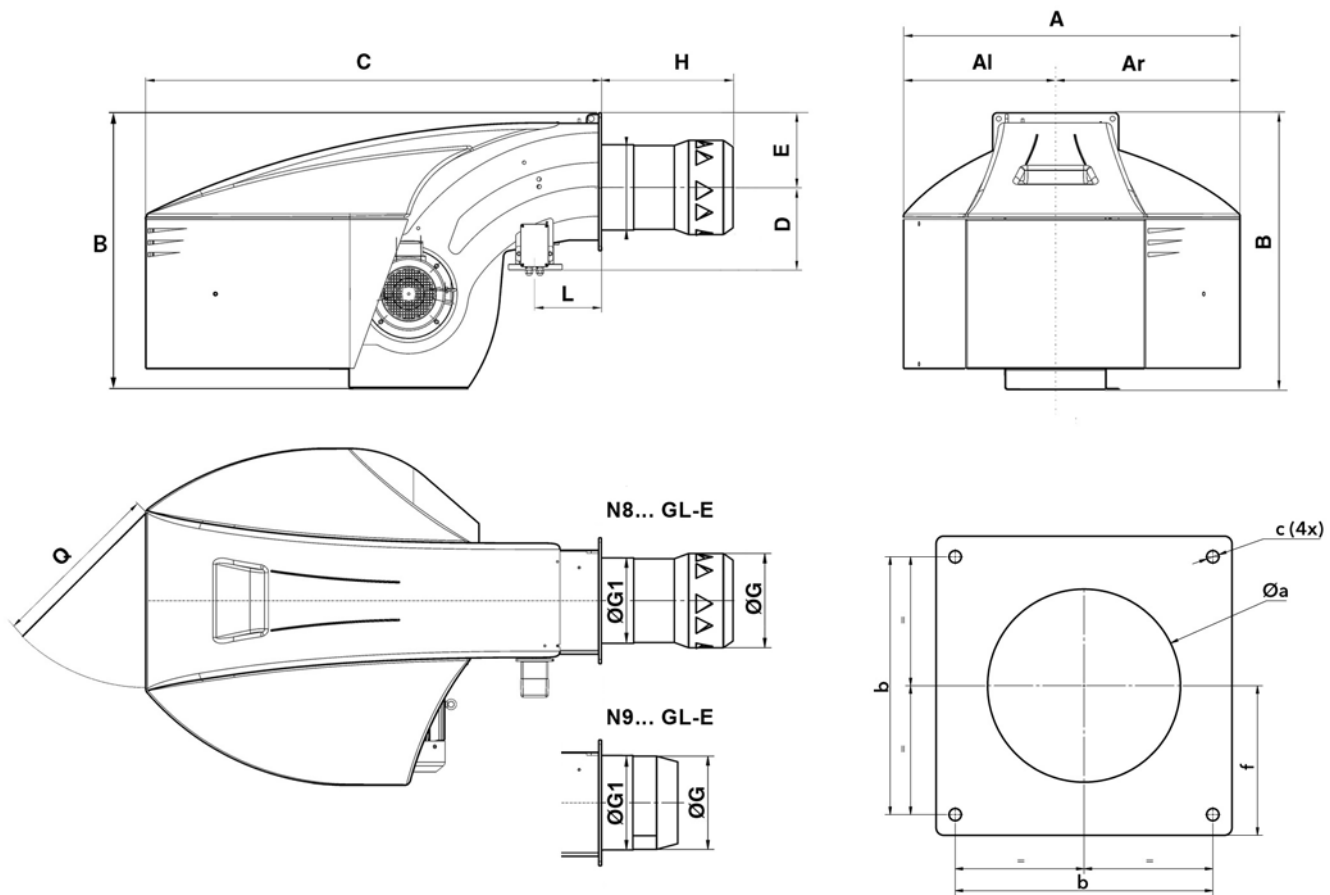

Model	A	AI	Ar	B	C	D	E	ØG	ØG1	H			L	Q	Øa	b	c	f
										KN	KM	KL						
N8.5800 GL-E	1325	670	655	1231	1930	307	293	400	376	562	702	842	230	800	415-480	505	M20	293
N8.7100 GL-E	1325	670	655	1231	1930	307	293	415	376	583	723	863	230	800	430-480	505	M20	293
N9.8700 GL-E	1414	669	745	1291	1928	416	293	431,5	438,5	355	505	655	230	800	450-480	505	M20	293
N9.10400 GL-E	1414	669	745	1291	1928	416	293	431,5	438,5	355	505	655	230	800	450-480	505	M20	293

PACKAGING

The burner is delivered on a pallet with:

- burner body with mounted combustion head
- gas train and filter
- boiler fixing accessories
- technical documentation

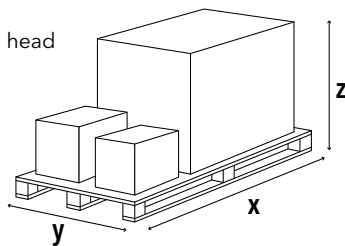

Model	Dimensions (mm)			Gross weight (kg)
	X	Y	Z	
N8.5800 GL-E	2900	1600	1573	700
N8.7100 GL-E	2900	1600	1573	700
N9.8700 GL-E	2900	1600	1573	760
N9.10400 GL-E	2900	1600	1573	760

N8 GL-E / N9 GL-E

800 ... 10620 kW

Two stage progressive/modulating electronic in gas and in light oil

PRESSURE LOSS [BURNER HEAD + GAS TRAIN] (mbar)

N8.5800 GL-E

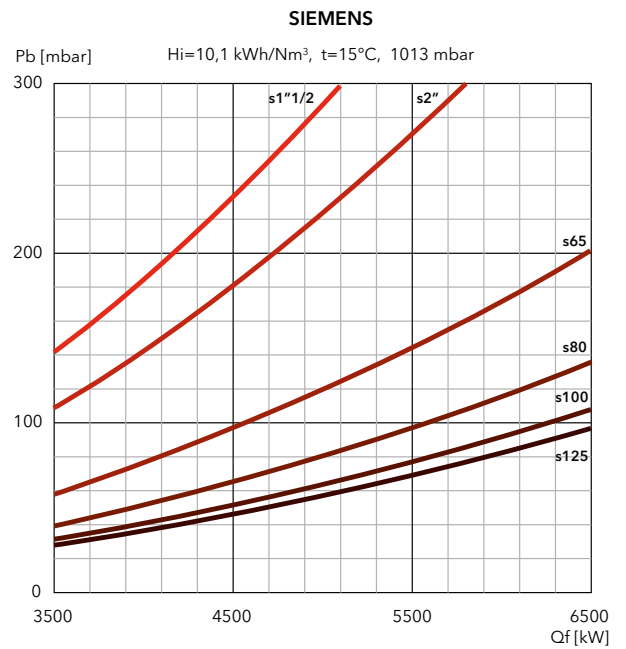
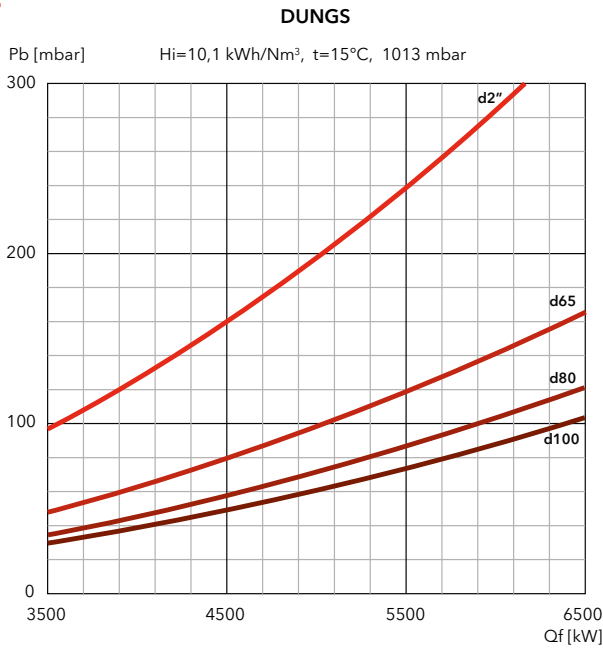

N8.7100 GL-E

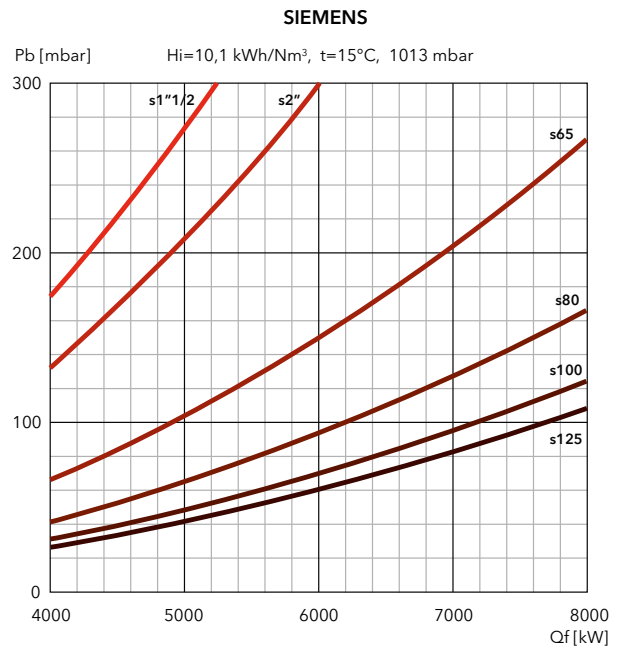
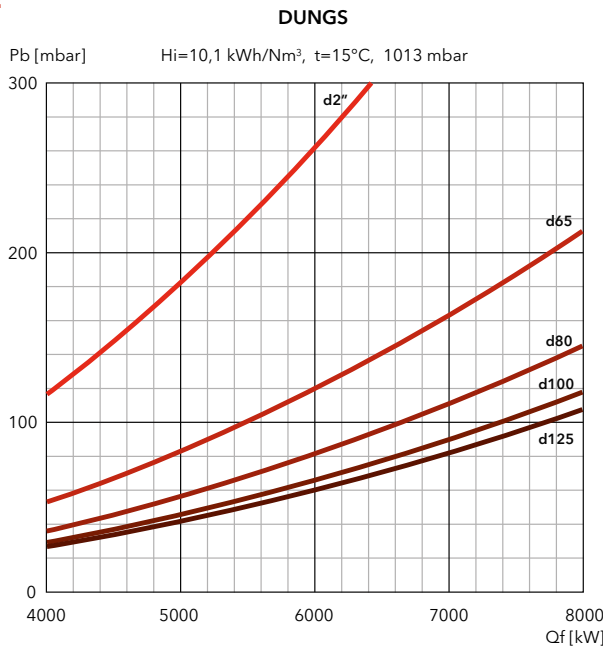

FILTERS

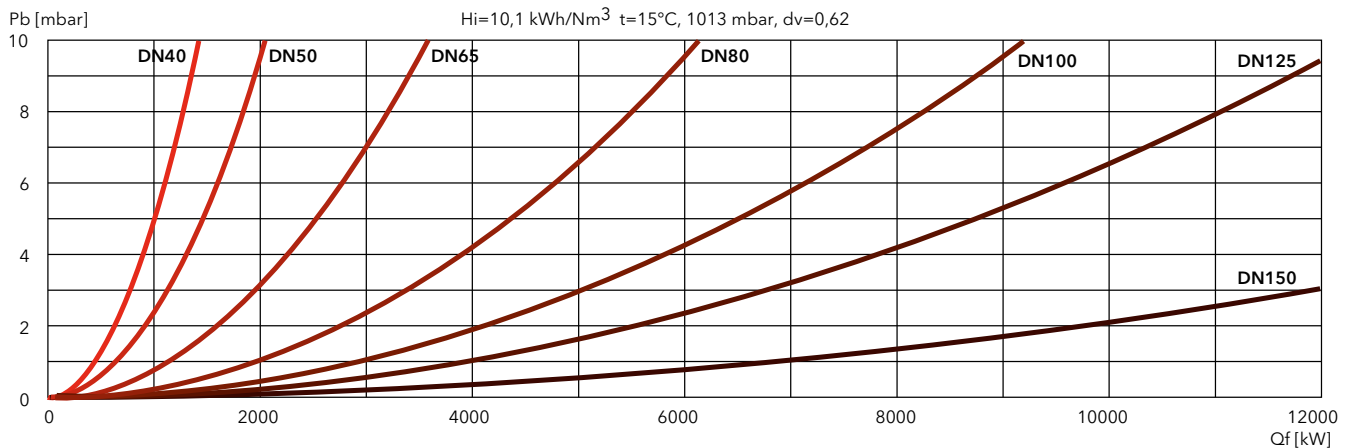



PRESSURE LOSS [BURNER HEAD + GAS TRAIN] (mbar)

N9.8700 GL-E

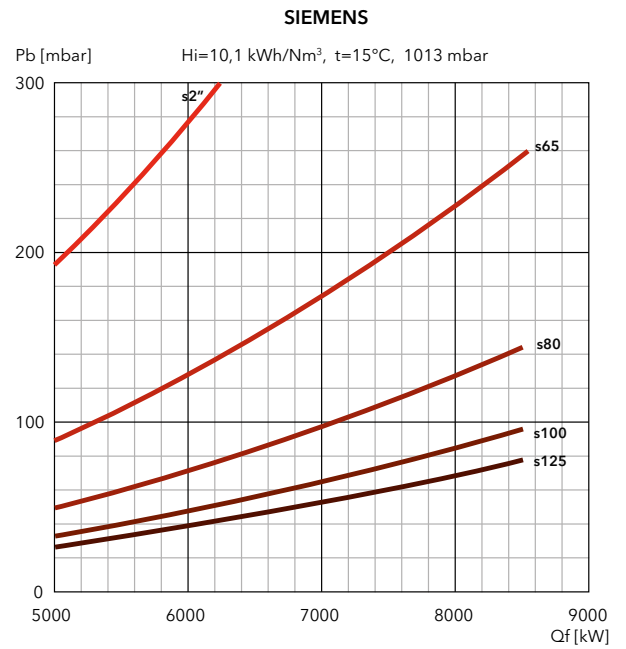
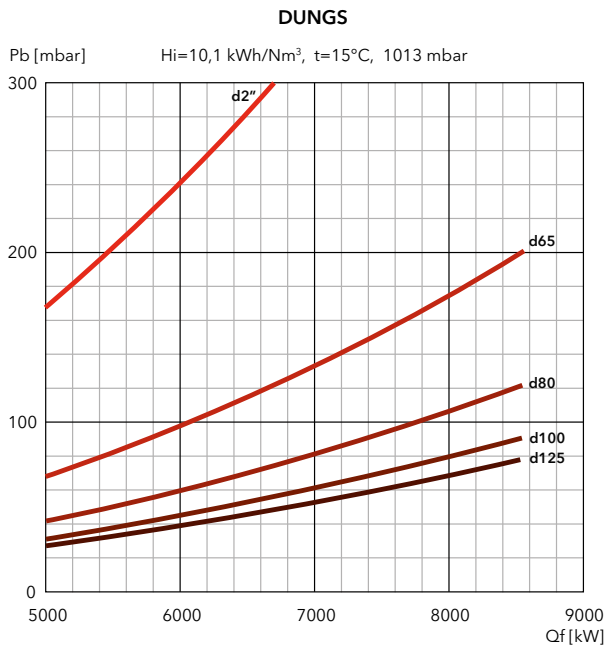

N9.10400 GL-E

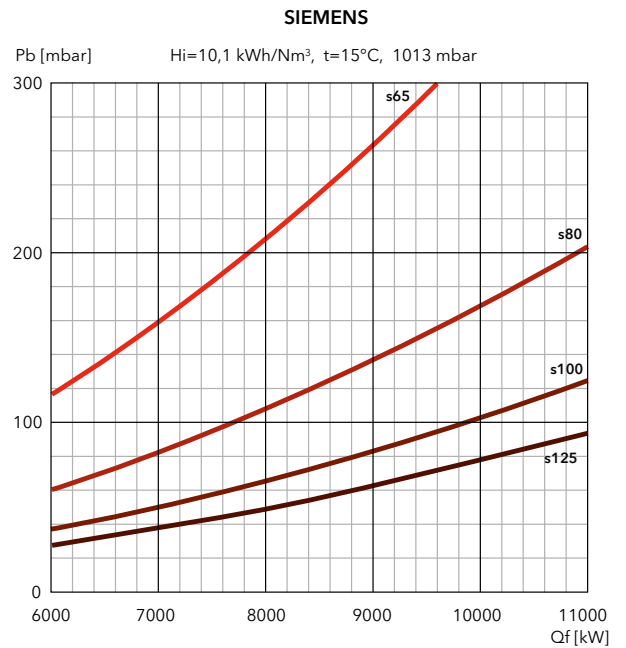
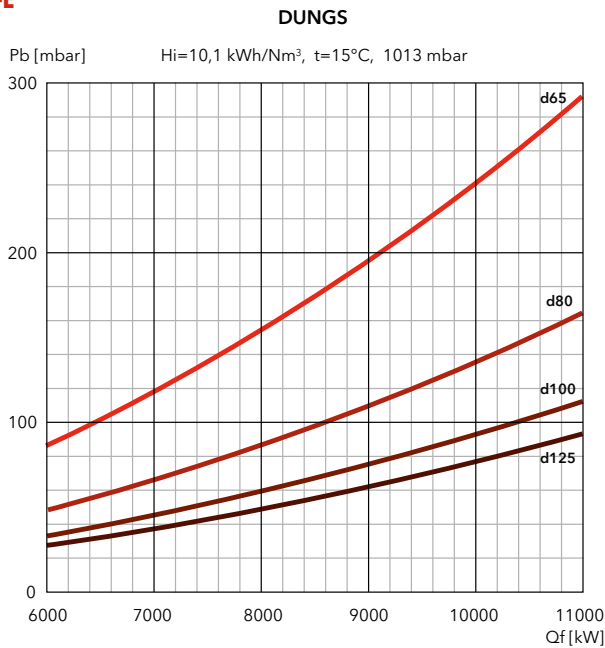

FILTERS

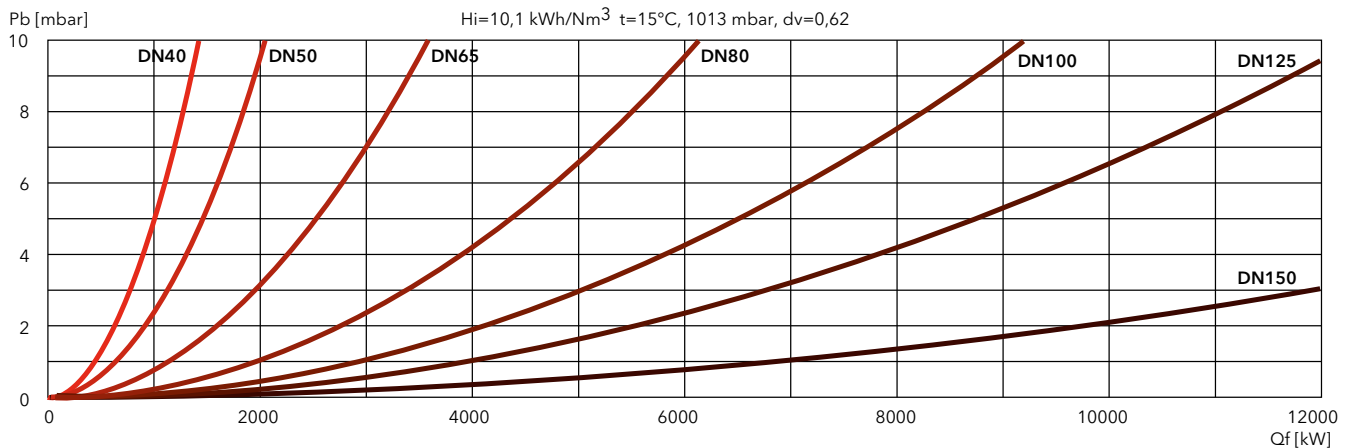

N6 L-EF3 / N7 L-EF3

360 ... 4820 kW

Two stage progressive/modulating electronic



- **Fuels:** light oil, viscosity 6 mm²/s at 20°C, Hi = 11,86 kWh/kg
- **Emission class:** Low NOx class 3 (≤120 mg/kWh) according to EN267
- **Protection level:** IP 41

TECHNICAL DATA

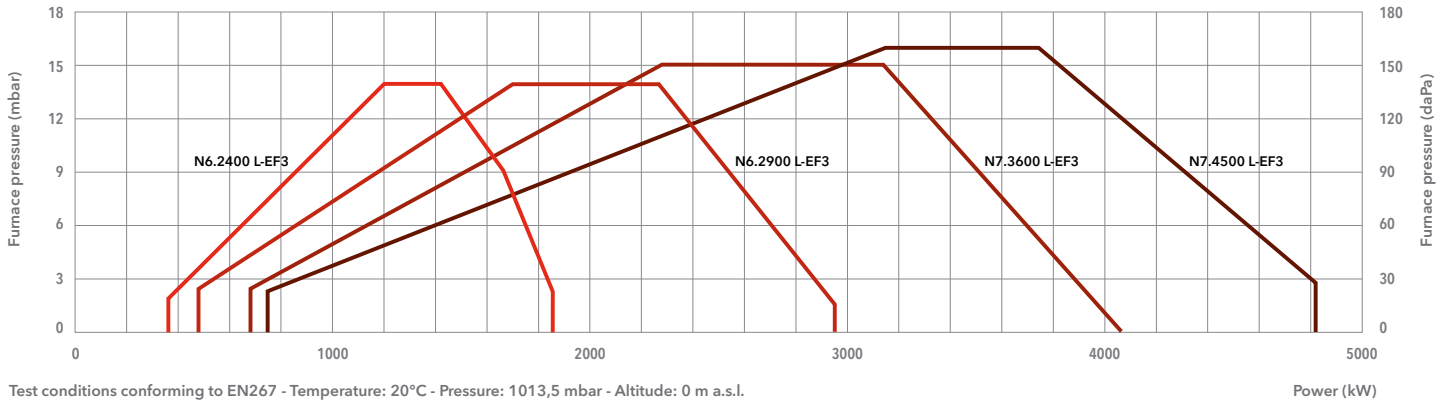

	N6.2400 L-EF3	N6.2900 L-EF3	N7.3600 L-EF3	N7.4500 L-EF3
Operating range	360 - 1850 kW	480 - 2950 kW	680 - 4070 kW	740 - 4820 kW
Fuel connection	DN20 x 1500 mm / R 1/2"	DN20 x 1500 mm / R 1/2"	DN20 x 1500 mm / R 3/4"	DN20 x 1500 mm / R 3/4"
Auxiliary voltage	1NPE AC 230 V - 50 Hz TN-S	1NPE AC 230 V - 50 Hz TN-S	1NPE AC 230 V - 50 Hz TN-S	1NPE AC 230 V - 50 Hz TN-S
Power supply	3PE AC 400 V - 50 Hz	3PE AC 400 V - 50 Hz	3PE AC 400 V - 50 Hz	3PE AC 400 V - 50 Hz
Control box / flame detector	BT300 / FFS08	BT300 / FFS08	BT300 / FFS08	BT300 / FFS08
Fan motor	50 Hz - 3 kW	50 Hz - 4 kW	50 Hz - 7,5 kW	50 Hz - 7,5 kW
Pump	SUNTECTA3	SUNTECTA3	SUNTECTA4	SUNTECTA5
Motor pump	50 Hz - 0,74 kW	50 Hz - 0,74 kW	50 Hz - 1,1 kW	50 Hz - 1,5 kW
Acoustic level	<71 dB(A)	<71 dB(A)	<76 dB(A)	<74 dB(A)
CE certificate	0085CL0215	0085CL0215	0085CL0215	0085CL0215
Complete burner codes	on request	on request	on request	on request



DIMENSIONS (mm)

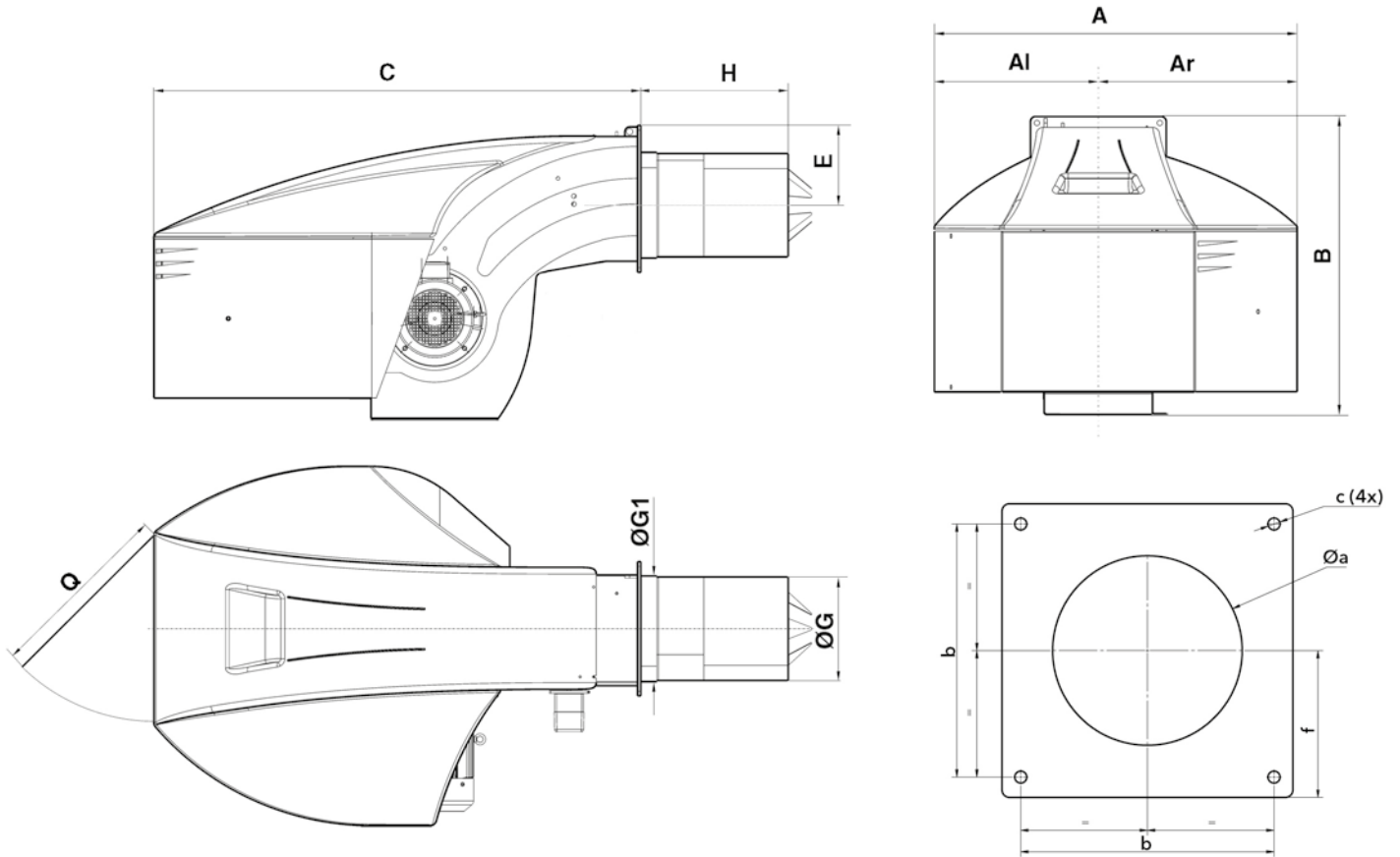

Model	A	AI	Ar	B	C	E	ØG	ØG1	H			Q	Øa	b	c	f
									KN	KM	KL					
N6... L-EF3	990	479	510	837	1361	225	263,5	270	330	450	570	600	300-340	340	M16	200
N7... L-EF3	1128	511	618	961	1529	255	325	332	375	505	635	600	360-400	400	M16	235

PACKAGING

The burner is delivered on a pallet with:

- burner body with mounted combustion head
- boiler fixing accessories
- technical documentation

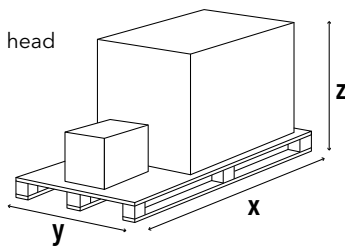

Model	Dimensions (mm)			Gross weight (kg)
	X	Y	Z	
N6.2400 L-EF3	2300	1500	1573	360
N6.2900 L-EF3	2300	1500	1573	360
N7.3600 L-EF3	2300	1500	1573	450
N7.4500 L-EF3	2300	1500	1573	450

N8 L-EF3 / N9 L-EF3 / N9 L-EUF

1100 ... 9570 kW

Two stage progressive/modulating electronic



- **Fuels:** light oil, viscosity 6 mm²/s at 20°C, Hi = 11,86 kWh/kg
- **Emission class:** Low NOx class 3 (≤120 mg/kWh) according to EN267
- **Protection level:** IP 41

TECHNICAL DATA

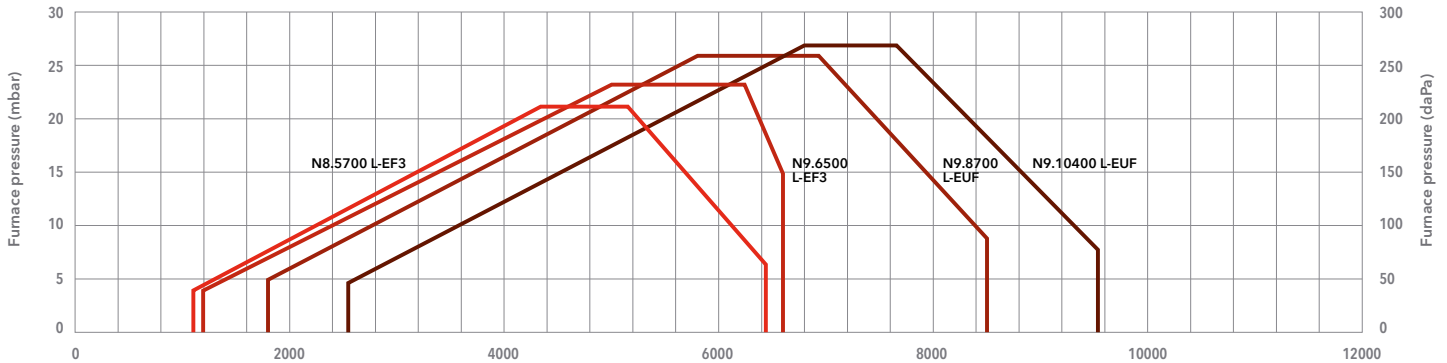

Test conditions conforming to EN267 - Temperature: 20°C - Pressure: 1013,5 mbar - Altitude: 0 m a.s.l.

Power (kW)

	N8.5700 L-EF3	N9.6500 L-EF3	N9.8700 L-EUF	N9.10400 L-EUF
Operating range	1100 – 6450 kW	1200 – 6600 kW	1800 – 8500 kW	2550 – 9570 kW
Fuel connection	DN20 x 1500 mm / R 3/4"	DN20 x 1500 mm / R 3/4"	DN20 x 1500 mm / R 3/4"	DN25 x 1500 mm / R 1"
Auxiliary voltage	1NPE AC 230 V – 50 Hz TN-S	1NPE AC 230 V – 50 Hz TN-S	1NPE AC 230 V – 50 Hz TN-S	1NPE AC 230 V – 50 Hz TN-S
Power supply	3PE AC 400 V – 50 Hz	3PE AC 400 V – 50 Hz	3PE AC 400 V – 50 Hz	3PE AC 400 V – 50 Hz
Control box / flame detector	BT300 / FFS08	BT300 / FFS08	BT300 / FFS08	BT300 / FFS08
Fan motor	50 Hz – 15 kW	50 Hz – 22 kW	50 Hz – 18,5 kW	50 Hz – 22 kW
Pump	SMG1630 – 1700 l/h	SMG1630 – 1700 l/h	SMG1630 – 1700 l/h	SMG1631 – 2200 l/h
Motor pump	50 Hz – 3 kW	50 Hz – 3 kW	50 Hz – 3 kW	50 Hz – 4 kW
Acoustic level	<80,2 dB(A)	<82,9 dB(A)	<81 dB(A)	<81,7 dB(A)
CE certificate	0085CL0215	0085CL0215	0085CL0215	0085CL0215
Complete burner codes	on request	on request	on request	on request



DIMENSIONS (mm)

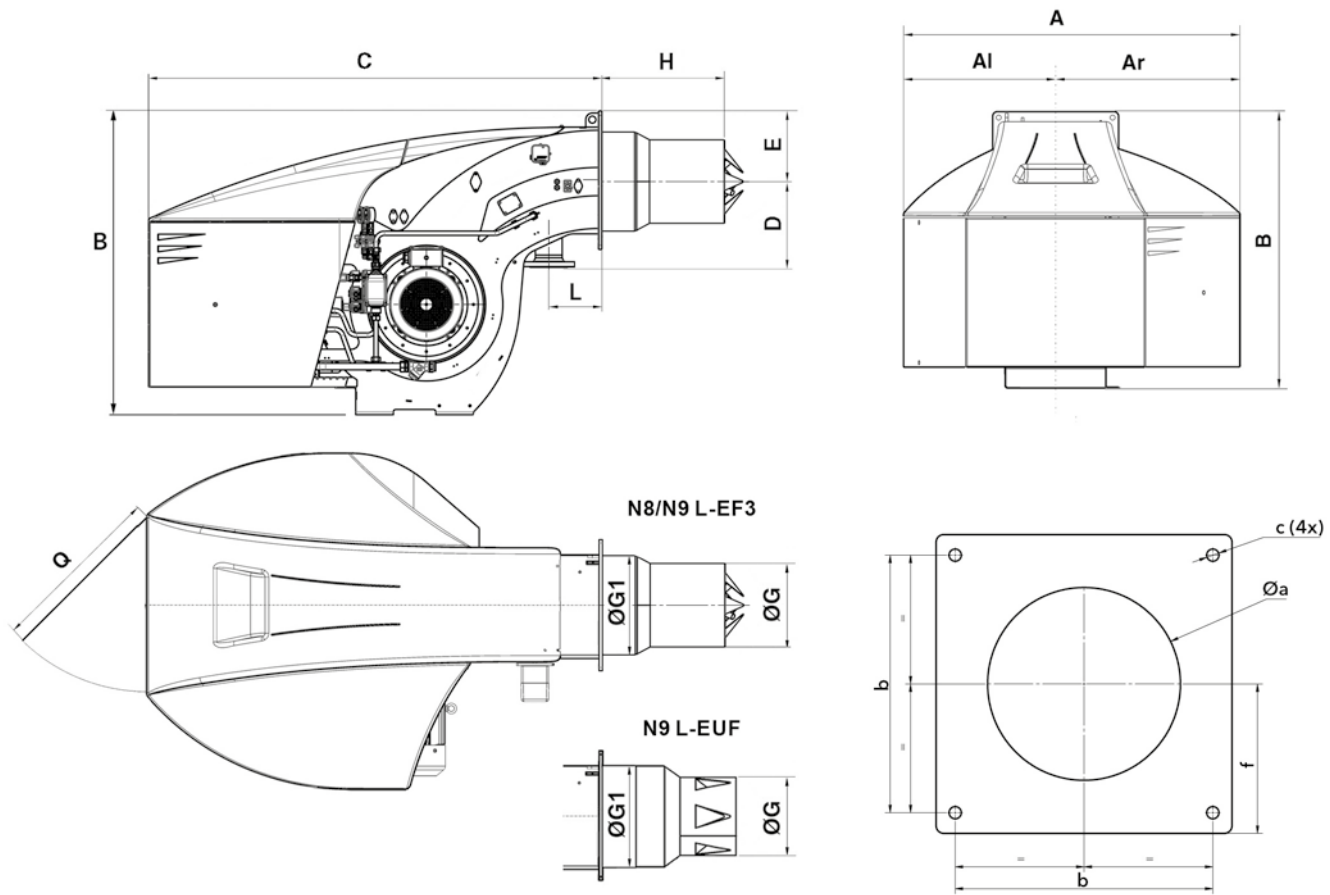

Model	A	AI	Ar	B	C	E	ØG	ØG1	H			Q	Øa	b	c	f
									KN	KM	KL					
N8.5700 L-EF3	1414	669	745	1291	1928	293	369	376	528	668	808	800	380-410	505	M20	293
N9.6500 L-EF3	1414	669	745	1291	1928	293	369	438,5	543	693	843	800	445-480	505	M20	293
N9.8700 L-EUF	1414	669	745	1291	1928	293	325	438,5	575	725	875	800	445-480	505	M20	293
N9.10400 L-EUF	1414	669	745	1291	1928	293	335	438,5	575	725	875	800	445-480	505	M20	293

PACKAGING

The burner is delivered on a pallet with:

- burner body with mounted combustion head
- boiler fixing accessories
- technical documentation

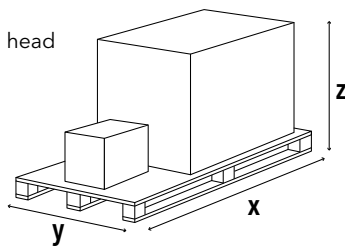

Model	Dimensions (mm)			Gross weight (kg)
	X	Y	Z	
N8.5700 L-EF3	2900	1600	1573	700
N9.6500 L-EF3	2900	1600	1573	760
N9.8700 L-EUF	2900	1600	1573	760
N9.10400 L-EUF	2900	1600	1573	760

N6 L-E / N7 L-E

510 ... 4900 kW

Two stage progressive/modulating electronic



- **Fuels:** light oil, viscosity 6 mm²/s at 20°C, Hi = 11,86 kWh/kg
- **Emission class:** Low NOx class 2 (≤185 mg/kWh) according to EN267
- **Protection level:** IP 41

TECHNICAL DATA

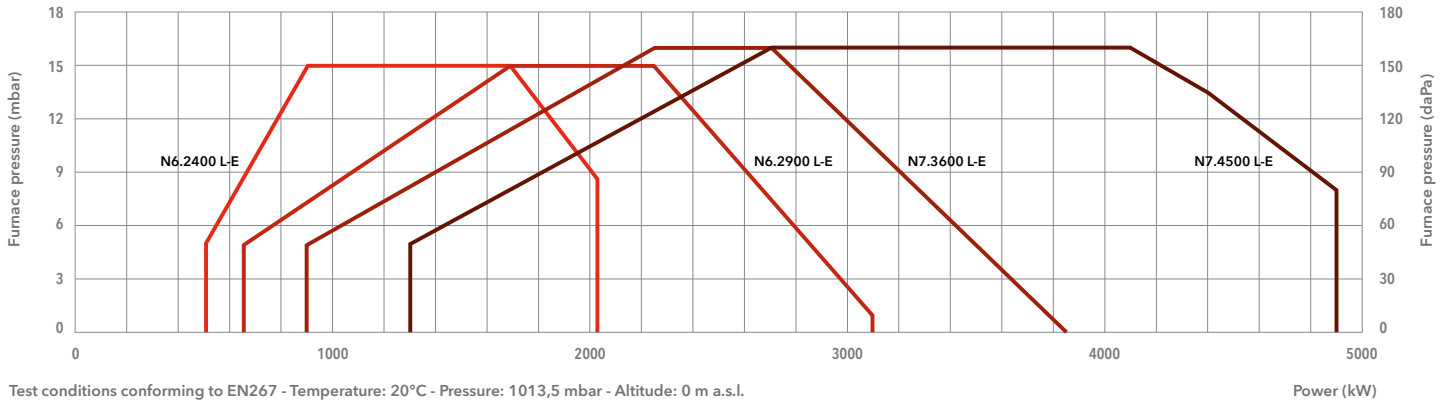

Test conditions conforming to EN267 - Temperature: 20°C - Pressure: 1013,5 mbar - Altitude: 0 m a.s.l.

	N6.2400 L-E	N6.2900 L-E	N7.3600 L-E	N7.4500 L-E
Operating range	510 - 2030 kW	650 - 3100 kW	900 - 3850 kW	1300 - 4900 kW
Fuel connection	DN20 x 1500 mm / R 1/2"	DN20 x 1500 mm / R 1/2"	DN20 x 1500 mm / R 3/4"	DN20 x 1500 mm / R 3/4"
Auxiliary voltage	1NPE AC 230 V - 50 Hz TN-S	1NPE AC 230 V - 50 Hz TN-S	1NPE AC 230 V - 50 Hz TN-S	1NPE AC 230 V - 50 Hz TN-S
Power supply	3PE AC 400 V - 50 Hz	3PE AC 400 V - 50 Hz	3PE AC 400 V - 50 Hz	3PE AC 400 V - 50 Hz
Control box / flame detector	BT300 / QRA2	BT300 / QRA2	BT300 / QRA2	BT300 / QRA2
Fan motor	50 Hz - 3 kW	50 Hz - 4 kW	50 Hz - 5,5 kW	50 Hz - 7,5 kW
Pump	SUNTEC TA3	SUNTEC TA3	SUNTEC TA4	SUNTEC TA5
Motor pump	50 Hz - 0,74 kW	50 Hz - 0,74 kW	50 Hz - 1,1 kW	50 Hz - 1,5 kW
Acoustic level	<70 dB(A)	<71 dB(A)	<74 dB(A)	<75 dB(A)
CE certificate	0085CL0215	0085CL0215	0085CL0215	0085CL0215
Complete burner codes	on request	on request	on request	on request



DIMENSIONS (mm)

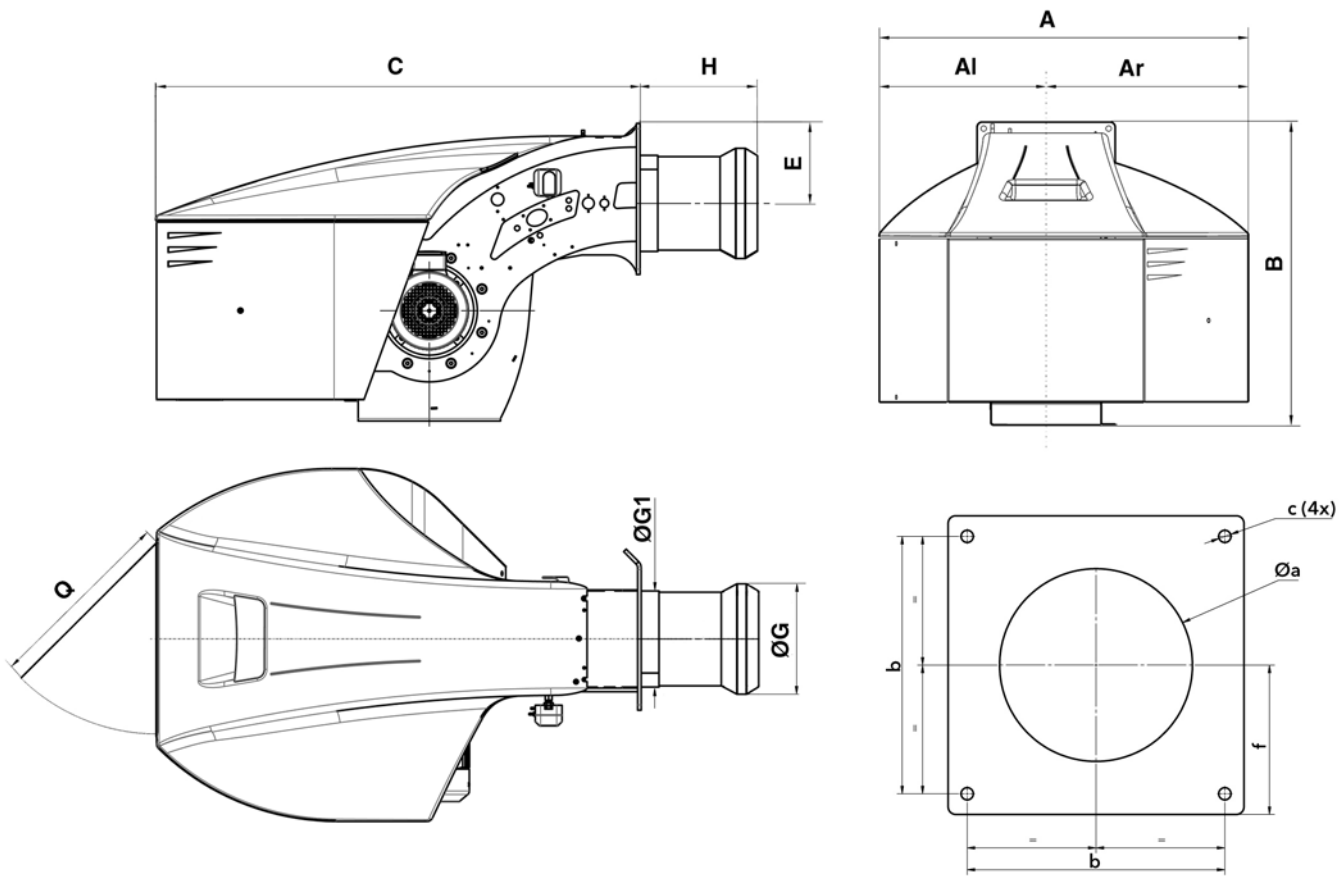

Model	A	AI	Ar	B	C	E	ØG	ØG1	H			Q	Øa	b	c	f
									KN	KM	KL					
N6.2400 L-E	990	479	510	837	1361	225	290	270	330	450	570	600	300-340	340	M16	200
N6.2900 L-E	990	479	510	837	1361	225	310	270	330	450	570	600	320-340	340	M16	200
N7.3600 L-E	1128	511	618	961	1529	255	330	332	375	505	635	600	340-400	400	M16	235
N7.4500 L-E	1128	511	618	961	1529	255	370	332	375	505	635	600	380-400	400	M16	235

PACKAGING

The burner is delivered on a pallet with:

- burner body with mounted combustion head
- boiler fixing accessories
- technical documentation

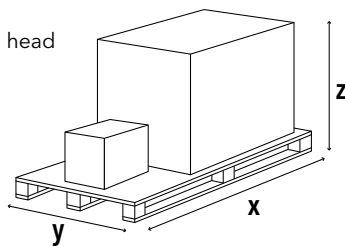

Model	Dimensions (mm)			Gross weight (kg)
	X	Y	Z	
N6.2400 L-E	2300	1500	1573	360
N6.2900 L-E	2300	1500	1573	360
N7.3600 L-E	2300	1500	1573	450
N7.4500 L-E	2300	1500	1573	450

N8 L-E / N9 L-E

1350 ... 10620 kW

Two stage progressive/modulating electronic



- **Fuels:** light oil, viscosity 6 mm²/s at 20°C, Hi = 11,86 kWh/kg
- **Emission class:** Low NOx class 2 (≤185 mg/kWh) according to EN267
- **Protection level:** IP 41

TECHNICAL DATA

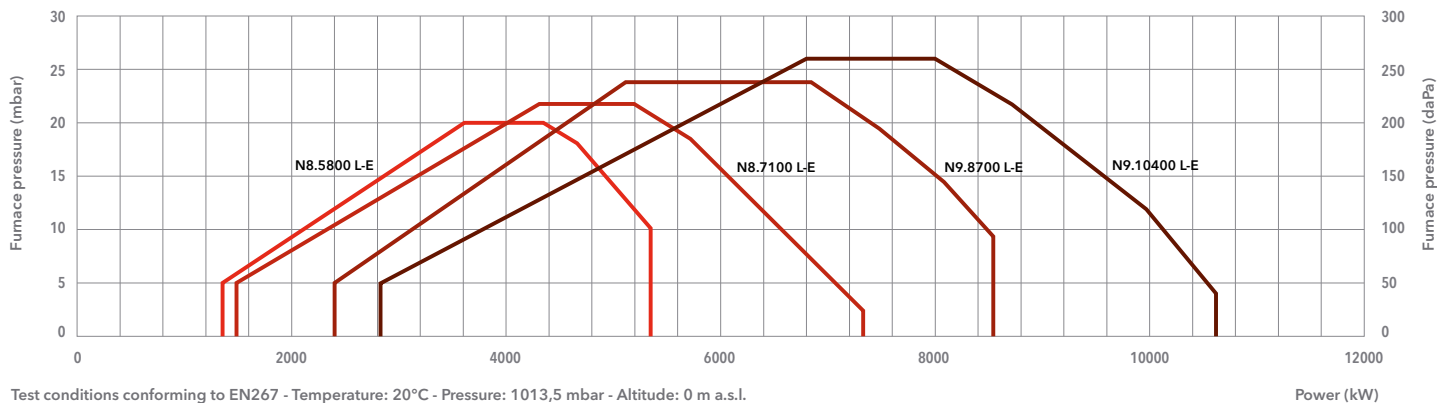

Test conditions conforming to EN267 - Temperature: 20°C - Pressure: 1013,5 mbar - Altitude: 0 m a.s.l.

	N8.5800 L-E	N8.7100 L-E	N9.8700 L-E	N9.10400 L-E
Operating range	1350 - 5350 kW	1470 - 7340 kW	2400 - 8530 kW	2820 - 10620 kW
Fuel connection	DN20 x 1500 mm / R 3/4"	DN20 x 1500 mm / R 3/4"	DN25 x 1500 mm / R 1"	DN25 x 1500 mm / R 1"
Auxiliary voltage	1NPE AC 230 V - 50 Hz TN-S	1NPE AC 230 V - 50 Hz TN-S	1NPE AC 230 V - 50 Hz TN-S	1NPE AC 230 V - 50 Hz TN-S
Power supply	3PE AC 400 V - 50 Hz	3PE AC 400 V - 50 Hz	3PE AC 400 V - 50 Hz	3PE AC 400 V - 50 Hz
Control box / flame detector	BT300 / QRA2	BT300 / QRA2	BT300 / QRA2	BT300 / QRA2
Fan motor	50 Hz - 11 kW	50 Hz - 15 kW	50 Hz - 18,5 kW	50 Hz - 22 kW
Pump	SMG1630 - 1700 l/h	SMG1630 - 1700 l/h	SMG1631 - 2200 l/h	SMG1631 - 2200 l/h
Motor pump	50 Hz - 3 kW	50 Hz - 3 kW	50 Hz - 4 kW	50 Hz - 4 kW
Acoustic level	<77,4 dB(A)	<79,5 dB(A)	<81 dB(A)	<81,7 dB(A)
CE certificate	0085CL0215	0085CL0215	0085CL0215	0085CL0215
Complete burner codes	on request	on request	on request	on request



DIMENSIONS (mm)

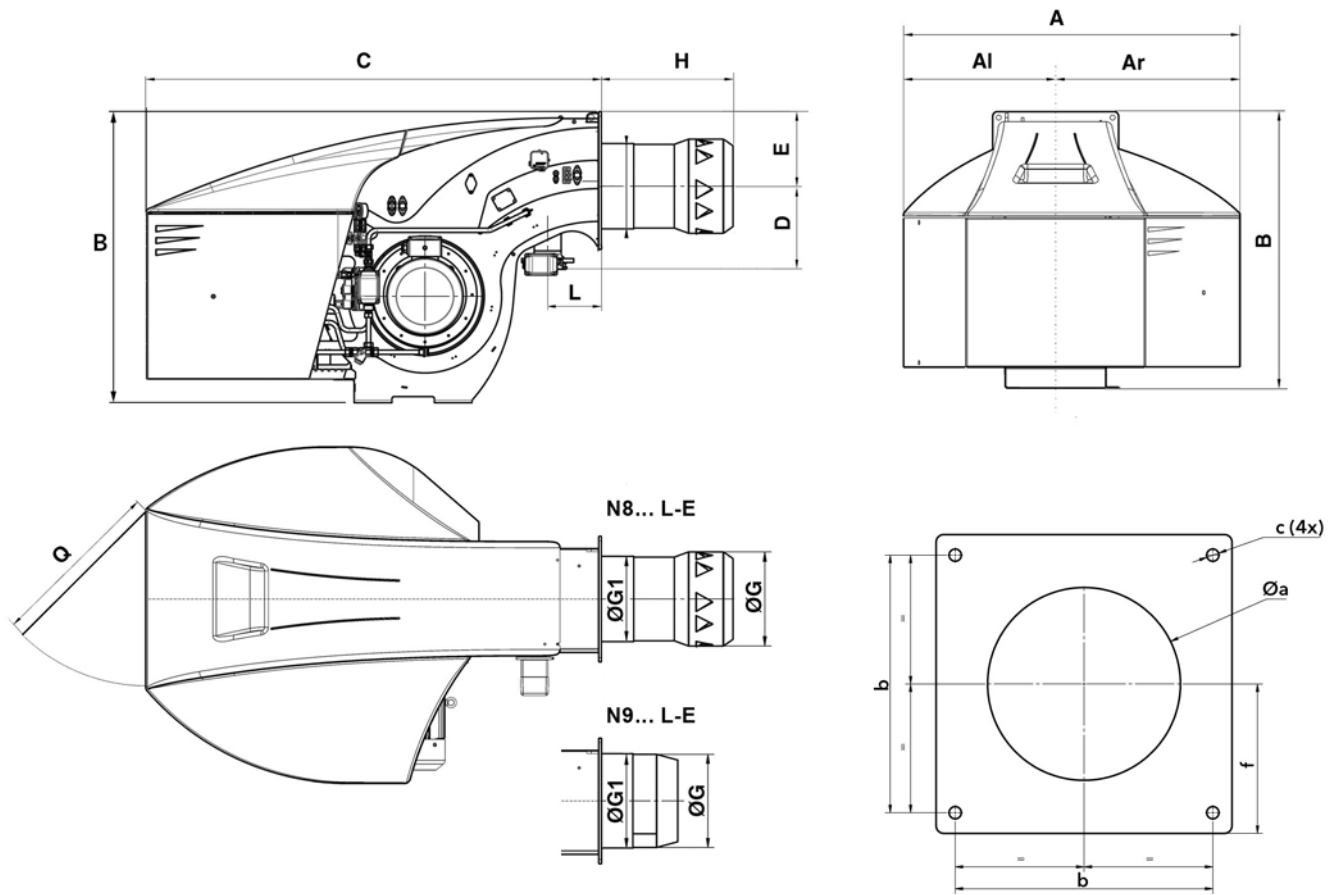

Model	A	AI	Ar	B	C	E	ØG	ØG1	H			Q	Øa	b	c	f
									KN	KM	KL					
N8.5800 L-E	1414	669	745	1231	1930	293	400	376	562	702	842	800	430-480	505	M20	293
N8.7100 L-E	1414	669	745	1231	1930	293	415	376	583	723	863	800	445-480	505	M20	293
N9.8700 L-E	1414	669	745	1291	1928	293	431,5	438,5	355	505	655	800	445-480	505	M20	293
N9.10400 L-E	1414	669	745	1291	1928	293	431,5	438,5	355	505	655	800	445-480	505	M20	293

PACKAGING

The burner is delivered on a pallet with:

- burner body with mounted combustion head
- boiler fixing accessories
- technical documentation

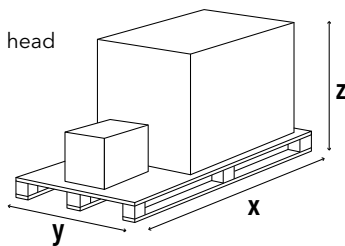

Model	Dimensions (mm)			Gross weight (kg)
	X	Y	Z	
N8.5800 L-E	2900	1600	1573	700
N8.7100 L-E	2900	1600	1573	700
N9.8700 L-E	2900	1600	1573	760
N9.10400 L-E	2900	1600	1573	760

LCM MODULE (for communication, O₂ control, frequency converter)

Module mounted in factory, requested for O ₂ control, Variatron and communication buses connections (the module is available also on request as a separate kit) Note: only one LCM module is necessary for these 3 options; it is already included in the GL-E.../BT3 versions	3752433
--	---------

MODULATING OPERATION

Regulator RWF55 + instruction manual Kit mounted in factory on the switch cabinet to be connected to the appropriate probe (see "BURNER KITS" session)	3752364
---	---------

FREQUENCY CONVERTER

Variatron mounted in factory inside the switch cabinet including the VSM module for the burners with BT300 control box

Note: one LCM module is required and must be ordered separately (for burners equipped with the BT300)

Frequency converter for N6.2400	3751418
Frequency converter for N6.2900	3751419
Frequency converter for N7.3600 G-E/G-EU2/GL-E/L-E	3751420
Frequency converter for N7.3600 G-EF3/GL-EF3/L-EF3 and N7.4500	3751421
Frequency converter for N8.5800 G-...	3750778
Frequency converter for N8.7100 G-...	3750779
Frequency converter for N9.8700 G-...	3750780
Frequency converter for N9.10400 G-...	3750781
Frequency converter for N8.5800 GL-... and L-...	3751422
Frequency converter for N8.7100 GL-... and L-...	3751423
Frequency converter for N9.8700 GL-E and L-...	3751424
Frequency converter for N9.10400 GL-E and L-...	3751425
Frequency converter for N9.8700 GL-EUF	3751498
Frequency converter for N9.10400 GL-EUF	3751499

FREQUENCY CONVERTER ARRANGEMENT

Burner prepared to be connected to an external frequency inverter

NOTE: one LCM module is required and must be ordered separately (for burners equipped with the BT300)

N6.2400 G-... prepared for an external frequency converter of 3 kW	3751426
N6.2900 G-... prepared for an external frequency converter of 4 kW	3751427
N7.3600 G-E and N7.4500 G-EU2 prepared for an external frequency converter of 5,5 kW	3751428
N7.3600 G-EF3 and N7.4500 G-E/G-EF3 prepared for an external frequency converter of 7,5 kW	3751429
N8.5800 G-E prepared for an external frequency converter of 11 kW	3751113
N8.7100 G-E prepared for an external frequency converter of 15 kW	3751114
N9.8700 G-E prepared for an external frequency converter of 18,5 kW	3751115
N9.10400 G-E prepared for an external frequency converter of 22 kW	3751116
N6 GL-... and N6 L-... prepared for an external frequency converter of 3 kW	3751430
N6 GL-... and N6 L-... prepared for an external frequency converter of 4 kW	3751431
N7 GL-... and N7 L-... prepared for an external frequency converter of 5,5 kW	3751432
N7 GL-... and N7 L-... prepared for an external frequency converter of 7,5 kW	3751433
N8 GL-... and N8 L-... prepared for an external frequency converter of 11 kW	3751434
N8 GL-... and N8 L-... prepared for an external frequency converter of 15 kW	3751435
N9.8700 GL-E and N9 L-... prepared for an external frequency converter of 18,5 kW	3751436
N9.10400 GL-E/GL-EF3 and N9 L-... prepared for an external frequency converter of 22 kW	3751437
N9.8700 GL-EUF prepared for an external frequency converter of 18,5 kW	3751500
N9.10400 GL-EUF prepared for an external frequency converter of 22 kW	3751501

PED EQUIPMENT

Equipment of the gas train and the burner body for continuous operation (PED):

- controller and flame sensor approved for continuous operation,
- maximum gas pressure switch on the gas train,
- test burner (to bleed the gas train),
- PED Conformity Declaration.

Note: if required, the antivibrating coupling (to avoid mechanical tension) has to be selected as option

PED for N6/N7 G-E	with Siemens threaded gas trains	3750768
	with Siemens flanged gas trains	3750769
	with Dungs threaded gas trains	3750770
	with Dungs flanged gas trains	3750771
PED for N8/N9 G-E	with Siemens threaded gas trains	3751120
	with Siemens flanged gas trains	3751121
	with Dungs threaded gas trains	3751122
	with Dungs flanged gas trains	3751123
PED for N6/N7 G-EF3	with Siemens threaded gas trains	3750772
	with Siemens flanged gas trains	3750773
	with Dungs threaded gas trains	3750.873
	with Dungs flanged gas trains	3751058
PED for N6/N7 GL-E	with Siemens threaded gas trains	3751059
	with Siemens flanged gas trains	3751060
	with Dungs threaded gas trains	3751061
	with Dungs flanged gas trains	3750447
PED for N6/N7 GL-EF3	with Siemens threaded gas trains	3751062
	with Siemens flanged gas trains	3751063
	with Dungs threaded gas trains	3750450
	with Dungs flanged gas trains	3751064
PED for N8/N9 GL-E	with Siemens threaded gas trains	3751069
	with Siemens flanged gas trains	3751070
	with Dungs threaded gas trains	3751071
	with Dungs flanged gas trains	3751072
PED for N8/N9 GL-EF3	with Siemens threaded gas trains	3750460
	with Siemens flanged gas trains	3751073
	with Dungs threaded gas trains	3751074
	with Dungs flanged gas trains	3751075
PED for N6...N9 G-... and GL-... with terminal block switch cabinet	with Siemens threaded gas trains	3750764
	with Siemens flanged gas trains	3750765
	with Dungs threaded gas trains	3750766
	with Dungs flanged gas trains	3750767
PED for N6/N7 L-E		3751065
PED for N6/N7 L-EF3		3751066
PED for N8/N9 L-E		3751067
PED for N8/N9 L-EF3		3751068

MAX GAS PRESSURE SWITCH (mounted on the gas train)

N6/N7 G-.../GL-...	with Siemens threaded gas trains	3751088
	with Siemens flanged gas trains	3751089
	with Dungs threaded gas trains	3751090
	with Dungs flanged gas trains	3751091
N8/N9 G-.../GL-...	with Siemens threaded gas trains	3751124
	with Siemens flanged gas trains	3751125
	with Dungs threaded gas trains	3751126
	with Dungs flanged gas trains	3751127
N6...N9 G-.../GL-... with terminal block switch cabinet	with Siemens threaded gas trains	3751076
	with Siemens flanged gas trains	3751077
	with Dungs threaded gas trains	3751078
	with Dungs flanged gas trains	3751079

STAR/DELTA MOTOR STARTER

Star/Delta 3,0 G/BT3 for N6.2400	3751414
Star/Delta 4,0 G/BT3 for N6.2900	3751415
Star/Delta 5,5 G/BT3 for N7.3600	3751416
Star/Delta 7,5 G/BT3 for N7.4500	3751417

BLIND DOOR

Door of the switch cabinet without any component. The switches and the power regulator (if required) are mounted inside the switch cabinet

For N6/N7 in gas and light oil operation	3751411
For N6/N7 in dual fuel operation	3751412
For N8/N9 in gas and light oil operation	3751119
For N8/N9 in dual fuel operation	3751413

REMOTE SIGNAL 4-20 mA

Remote signal 4-20 mA for BT300 burner variant (Note: one LCM module is required for burners equipped with BT3)	14099397
--	----------

O₂ TRIM FOR BT300, ETAMATIC AND ETAMATIC OEM, FMS/VMS

This kit is used to optimize the combustion in order to keep the air excess as much stable as possible irrespective of the changes that can occur during operations, for instance slight calorific value variations, combustion air temperature and pressure. This improves the seasonal efficiency and therefore reduces the fuel consumption.

The kit includes the following components:

- Lambda transmitter LT3
- Lambda probe LS2
- Probe installation fitting (PIF)
- Gas extraction device (GED)

The control unit has to be installed close to the probe (max 10 m of cable)
 The probe needs a calibration but no reference gas is necessary.
 The display shows the O₂ content.
 Maximum distance between the LT3 and the burner control panel is 500 m.

	Additional LSB modules installed at LT3	GED length	Code
Kit for O₂ trim (LT3 + LS2) Flue temp max 300 °C - Display for O₂ visualization (Note: for models equipped with BT3 this kit needs a LCM module installed in the burner control panel)	none	150 mm	3759296
		300 mm	3759297
		450 mm	3759298
	4x 0/4-20 mA output	150 mm	3759299
		300 mm	3759300
		450 mm	3759301
	4x 0/4-20 mA output + 4x digital output	150 mm	3759302
		300 mm	3759303
		450 mm	3759304

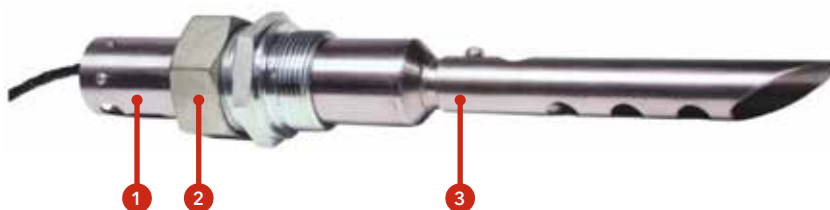

1. Lambda Probe LS2 in standard housing up to 300°C (572°F); default cable length is 2 m (6.5 ft), FEP, with connecting plug
2. Probe installation fitting (PIF)
3. Gas extraction device (GED)

The LS2 lambda probe is equipped with a 2 meter long connection cable that connects the sensor to the transmitter (LT3). It is possible to extend the connection up to a maximum distance of 10 meters (for greater lengths the conformity expires) with a ready-made cable and a probe connection box (PCB).

Description		Code
Extension for LS2	5m ready-made cable	3759318
	PCB (probe connection box)*	3759319

The PCB is a small terminal box that is connected to the 2 meter long cable already existing on the probe. The wiring between the PCB and the transmitter must be carried out on the construction site with suitable cables and trained personnel.

*: the PCB is mandatory if the end user chooses to use his own connecting cable and not one of those proposed (max total length remains 10m)

O₂/CO_e TRIM FOR BT300, ETAMATIC AND ETAMATIC OEM, FMS/VMS

This kit is used for optimizing the combustion in order to keep the air excess as low as possible in order to maximize the seasonal efficiency and therefore minimize the fuel consumption. In addition to the features of the O₂ trim only, this kit reduces the air excess to its minimum because this system continuously measures the content of unburned fuel (CO_e) in the flue: should the air excess be reduced too much, the CO_e raises and the system reacts by increasing the air excess in order to keep firing in safe conditions.

The kit includes the following components:

- Lambda transmitter LT3-F
- Lambda probe KS1D
- Probe installation fitting (PIF)
- Gas extraction device (GED)

The control unit has to be installed close to the probe (max 10 m of cable). The probe needs a calibration but no reference gas is necessary. The display shows the O₂ and CO_e content. Maximum distance between the LT3-F and the burner control panel is 500 m.

	Additional LSB modules installed at LT3-F	GED length	Code
Kit for O₂ trim and CO control (LT3-F + KS1D) Flue temp max 300 °C (Note: for models equipped with BT3 this kit needs a LCM module installed in the burner control panel)	none	150 mm	3759305
		300 mm	3759306
		450 mm	3759307
	4x 0/4-20 mA output	150 mm	3759308
		300 mm	3759309
		450 mm	3759310
	4x 0/4-20 mA output + 4x digital output	150 mm	3759311
		300 mm	3759312
		450 mm	3759313

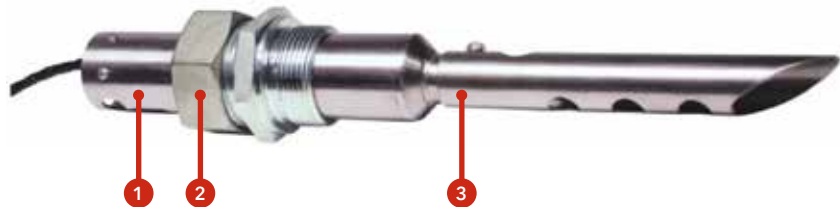

1. Lambda Probe KS1D in standard housing up to 300°C (572°F); default cable length is 2 m (6.5 ft), FEP, with connecting plug
2. Probe installation fitting (PIF)
3. Gas extraction device (GED)

The KS1D lambda probe is equipped with a 2 meter long connection cable that connects the sensor to the transmitter (LT3-F). It is possible to extend the connection up to a maximum distance of 10 meters (for greater lengths the conformity expires) with a ready-made cable and a probe connection box (PCB).

Description		Code
Extension for KS1D	5m ready-made cable	3759318
	PCB (probe connection box)*	3759319

The PCB is a small terminal box that is connected to the 2 meter long cable already existing on the probe. The wiring between the PCB and the transmitter must be carried out on the construction site with suitable cables and trained personnel.

*: the PCB is mandatory if the end user chooses to use his own connecting cable and not one of those proposed (max total length remains 10m)

REMOTE SOFTWARE

Kit to connect a PC laptop to the BT300 for its parametrization	LSA100 + USB/CAN + CD-Rom	3751130
---	---------------------------	---------

COMMUNICATION MODULES

Modules for external installation Note: one LCM module is required	ModBus/BT3 (EBM100)	3754456
	ProfiBus/BT3 (PBM100)	3752986
	Profinet/BT3 (EBM112)	3758317
	Ethernet/BT3	on request

POWER REGULATOR

Power regulator RWF55 stand-alone and kit wiring	on request
--	------------

PROBES

Immersion probes	PT 100: -50°/+400°C (100 mm) + pocket tube (76 mm)	3750070
	PT 100: 400°C (160 mm)	1758574269
	PT 100: 480°C (250 mm)	3751009
Pressure probes	0...1,6 bar	3752217
	0...2,5 bar	1758713722
	0...6 bar	1758640660
	0...10 bar	1758577280
	0...16 bar	1758577291
	0...25 bar	3751015

COUNTER FACE PLATE

CP11	for N6	3833908
CP12	for N7	3833909
CP13	for N8	3833910
CP14	for N9	3833911

- Equipment according EN746-2
- Permanent ventilation
- 60 Hz versions
- Remote display (BT3)
- Separate switch box / terminal strip version (Etamatic OEM)
- LPG firing
- Hinge flange
- "Burner ON" feedback signal

Other special requests can be submitted to your Sales Reference for feasibility evaluation

N

MONOBLOCK BURNERS FROM 1300 TO 22000 kW GAS, LIGHT OIL AND DUAL FUEL



HIGH POWER AND EASE OF USE

Where a compact solution is needed, a monoblock burner offers advantages over individual components. However, above a power output of 10 MW, the conventional burner becomes too heavy: ease of handling during installation and maintenance work suffers, the strain on the boiler door is too high.

The N burners solve this problem with innovative, weight-saving enclosure technology. The key feature is the physical division of the burner into a support frame and a separate air-routing housing.

SIMPLIFIED STRUCTURE TO IMPROVE USABILITY

The burner head and the housing have been almost entirely separated in order to allow sufficient space for the combustion components to be easily removed. The air pipe between the housing and the burner head is simply closed by a removable cover. It is no longer necessary to pivot the entire body of the burner to one side or the other.

An added advantage is the ability to fix the frame to the ground, depending on the application, thus relieving the boiler door from any mechanical stress.

ULTRA LOW NO_x TECHNOLOGY, UP TO 22 MW

Thanks to the introduction of the N11 platform and the innovative solutions of this range, ELCO is able to provide high performance and ease of use on its monoblock range up to 22 MW.

The implementation of the FGR System enables to guarantee NO_x emissions of less than 30 mg/kWh for all the models of the N range, while the new FX combustion head allow to reach values below 50 mg without implementing the external flue gas recirculating system.

ADVANCED DESIGN FOR LOW NOISE LEVEL

Special attention has been paid to the fan design. The burner's acoustic level meets industry standards, providing a more comfortable working environment. The two main characteristics which limit the noise emitted by a fan are a high and constant static pressure and the use of a wheel with rear facing blades. The result is a stable combustion and reduced noise at the air inlet.

RANGE OVERVIEW



MAIN TECHNICAL FEATURES

- Two stage progressive/modulating forced draught burner
- Fuels:
 - natural gas, Hi = 6,99 ... 11,39 kWh/Nm³
 - light oil, viscosity 6 mm²/s at 20°C, Hi = 11,86 kWh/kg
- Combustion technology:
 - Low NOx class 4 (≤60 mg/kWh), class 3 (≤80 mg/kWh) and class 2 (≤120 mg/kWh) in gas operation, according to EN676
 - Low NOx class 3 (≤120 mg/kWh) and class 2 (≤185 mg/kWh) in light oil operation, according to EN267
 - Models equipped with FGR System to reach NOx emission values below 30 mg/kWh
- Control box: built-in (Etamatic OEM control box installed inside the junction box) or external, according to customer requirements
- Three flame tube lengths available
- Secured burner head adjustments during maintenance (RTC System)
- Closing of the air damper on burner shut-down
- Multiple gas train matching according to the inlet gas pressure
- Gas train factory assembled and tested for tightness and electrical security
- Products are in compliance with EN676 and EN267 European standards and with the following directives:
 - 2014/35/UE Low Voltage Directive
 - 2014/30/UE EMC Directive
 - 2016/426/UE Gas Appliances Regulation
 - 2006/42/EC Machinery Directive
 - 2011/65/EU RoHS2 Directive

PRODUCT LIST

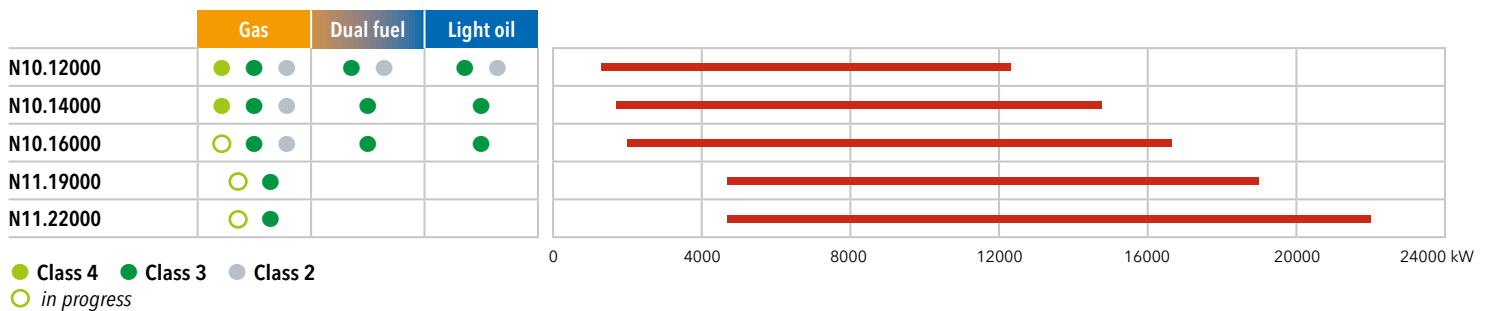

N

GAS

ULTRA Low NO_x**N10 G-EFX**

1300 ... 14300 kW

Two stage progressive/modulating electronic

NO_x
<50
mg/kWh

- **Fuels:** natural gas, Hi = 6,99 ... 11,39 kWh/Nm³
- **Emission class:** Low NO_x class 4 (≤60 mg/kWh) according to EN676
- **Protection level:** IP 41 (IP 54 as option)

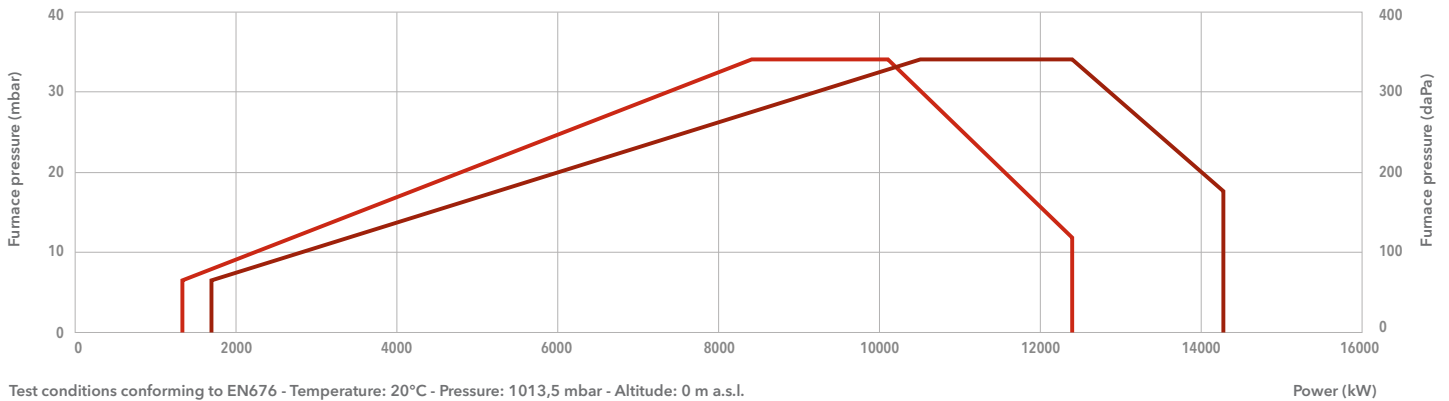
TECHNICAL DATA

	N10.12000.37 G-EFX	N10.14000.45 G-EFX
Operating range	1300 - 12400 kW	1700 - 14300 kW
Gas connection	DN100	DN100
Control box / flame detector	Etamatic OEM / FFS 08 UV-4	Etamatic OEM / FFS 08 UV-4
Fan motor	50/60 Hz - 37 kW	50/60 Hz - 45 kW
Acoustic level	< 95 dB(A)	< 95 dB(A)
Complete burner code	on request	on request

GAS TRAINS**DUNGS**

Model	Code
d DN80-DN100	on request
d DN100-DN100	on request
d DN125-DN100	on request

SIEMENS

Model	Code
s DN80-DN100	on request
s DN100-DN100	on request
s DN125-DN100	on request
s DN150-DN100	on request

FILTERS

Model	Code
FG-DN80	3757201
FG-DN100	3757195
FG-DN125	3757209
FG-DN150	3757210

i **Pressure drops graphs:** see following pages
Dimensions of gas trains and gas filters: see page 312



DIMENSIONS (mm)

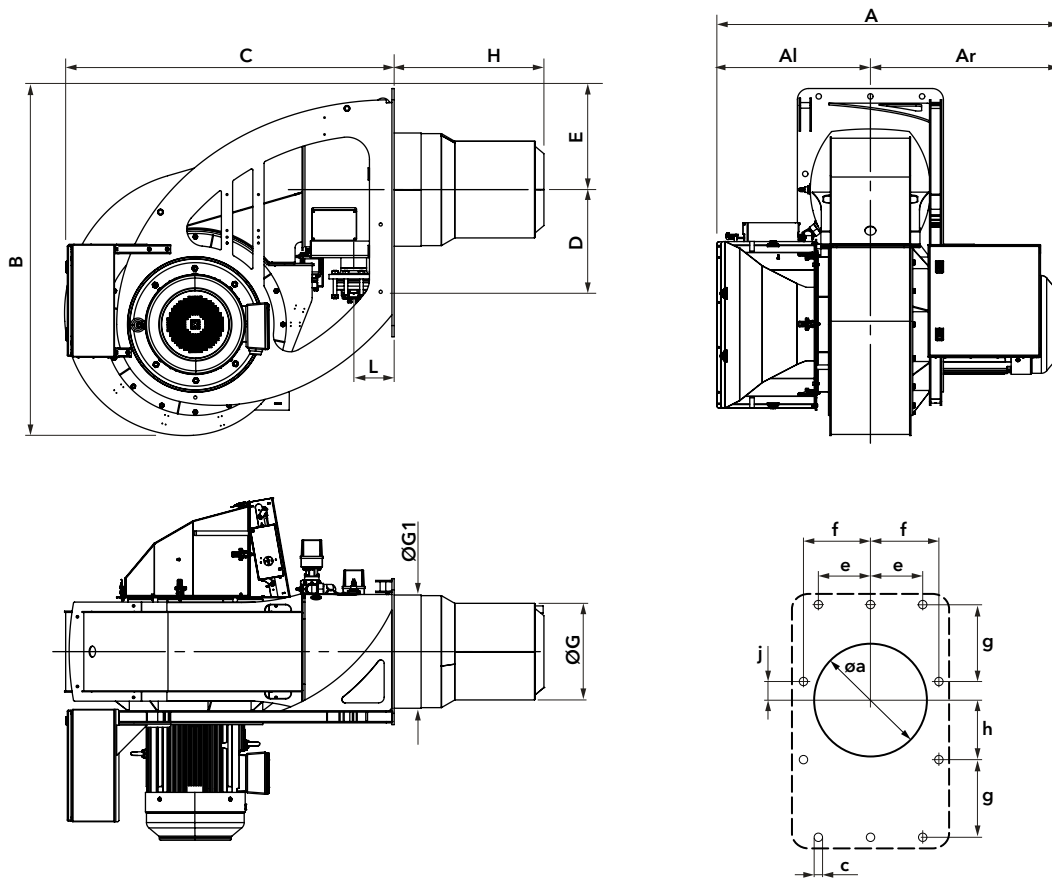

Model	A	Al	Ar	B	C	D	E	ØG	ØG1	H	L	Øa	c	e	f	g	h	j
N10.12000.37 G-EFX	1441	683	758	1545	1467	446	450	430	504	667*	180	525	M20	230	290	345	275	70
N10.14000.45 G-EFX	1530	683	847	1545	1467	446	450	467	504	667*	180	525	M20	230	290	345	275	70

*: different length on request

PACKAGING

The burner is delivered on a pallet with:

- burner body with mounted combustion head
- gas train and filter
- boiler fixing accessories
- technical documentation

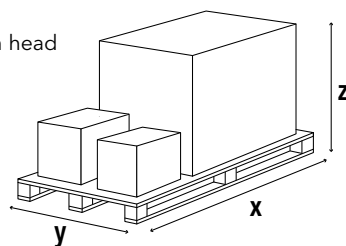

Model	Dimensions (mm)			Gross weight (kg)
	X	Y	Z	
N10.12000.37 G-EFX	2200	1800	1900	1000
N10.14000.45 G-EFX	2200	1800	1900	1070

N10 G-EFX

1300 ... 14300 kW

Two stage progressive/modulating electronic

PRESSURE LOSS [BURNER HEAD + GAS TRAIN] (mbar)

N10.12000.37 G-EFX

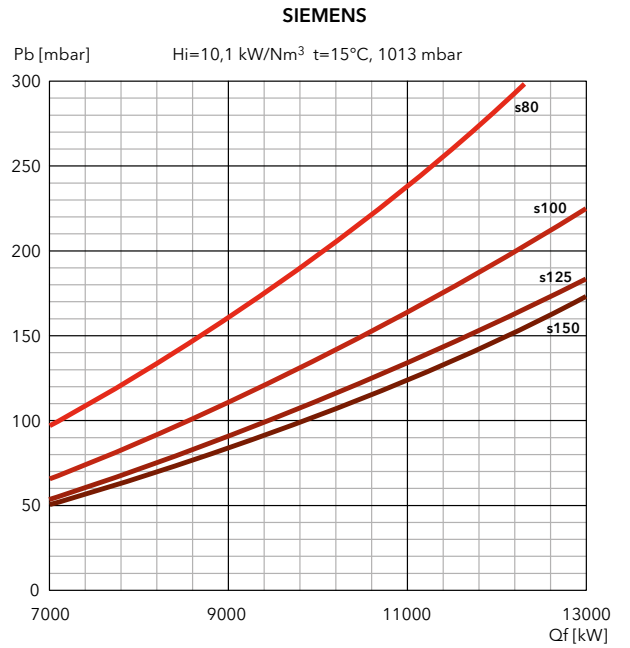
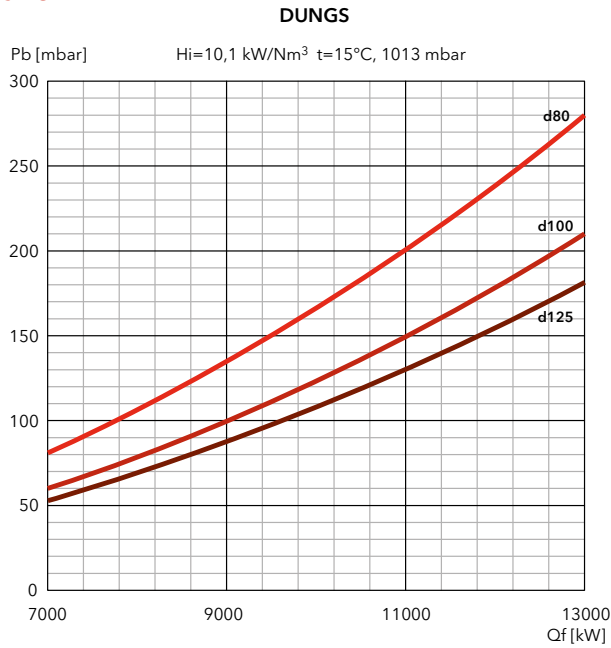

FILTERS

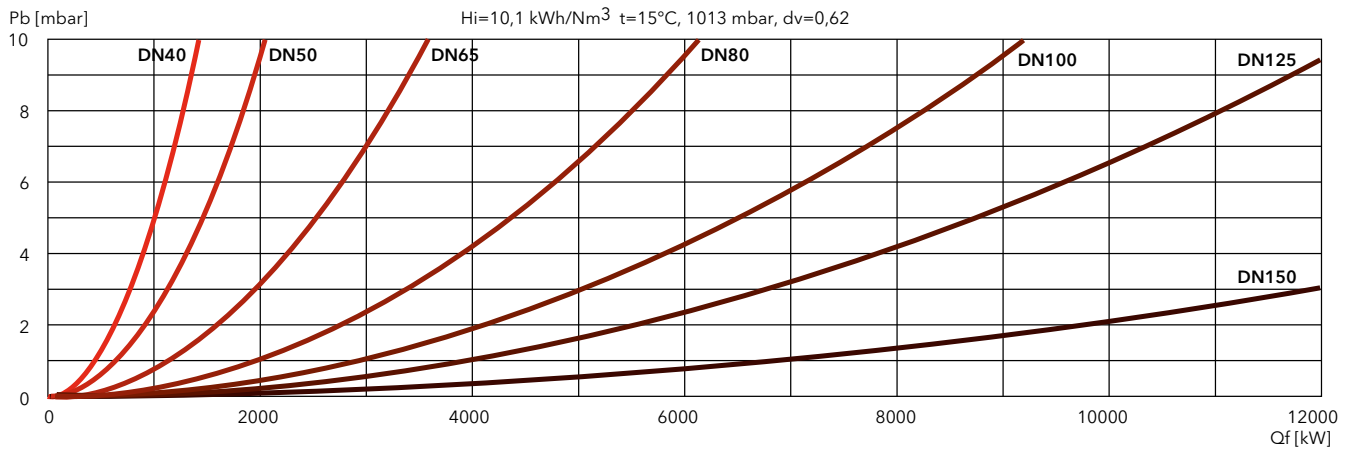



PRESSURE LOSS [BURNER HEAD + GAS TRAIN] (mbar)

N10.14000.45 G-EFX

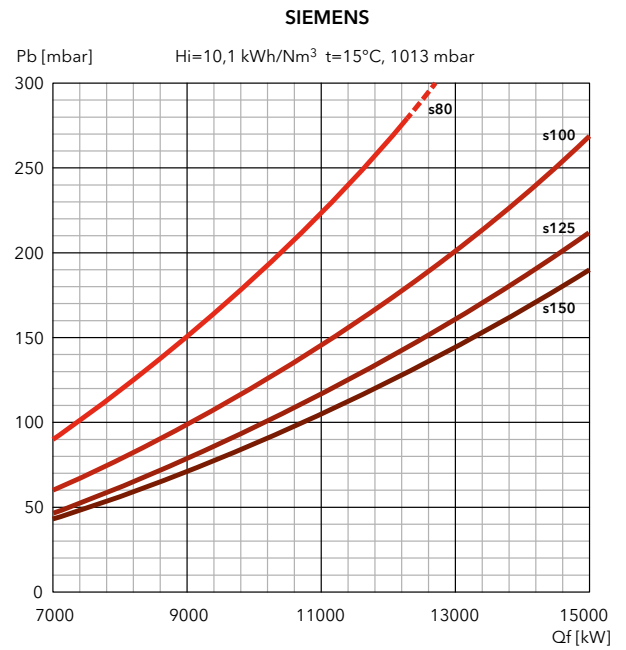
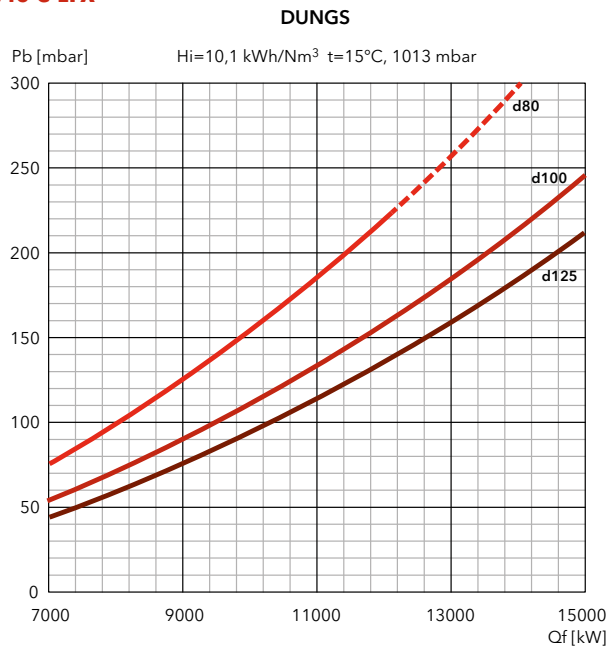

FILTERS

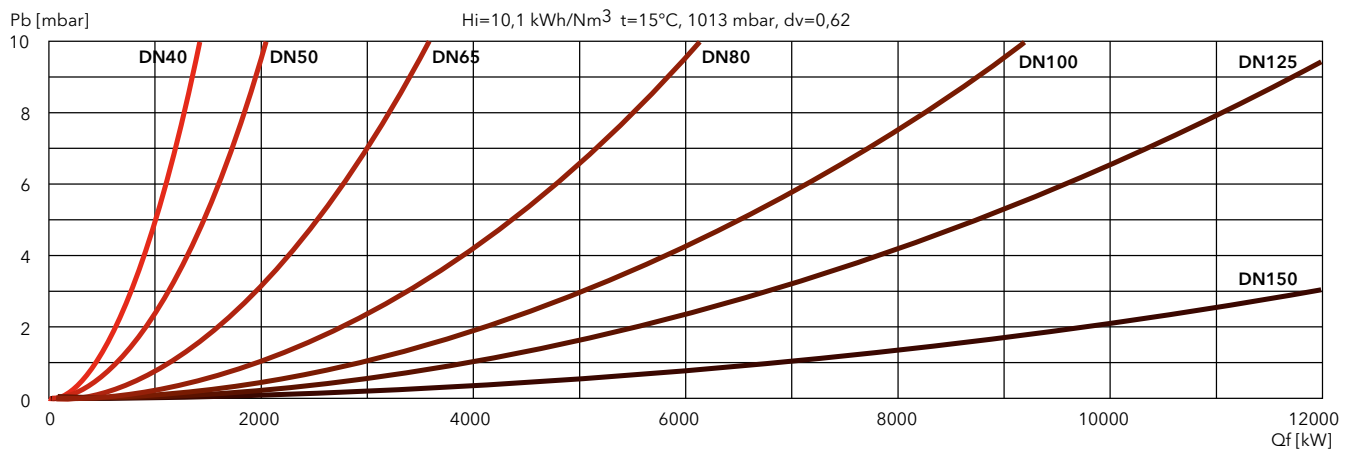

N

GAS

Low NO_x Class 3**N10 G-EU2**

1500 ... 16350 kW

Two stage progressive/modulating electronic

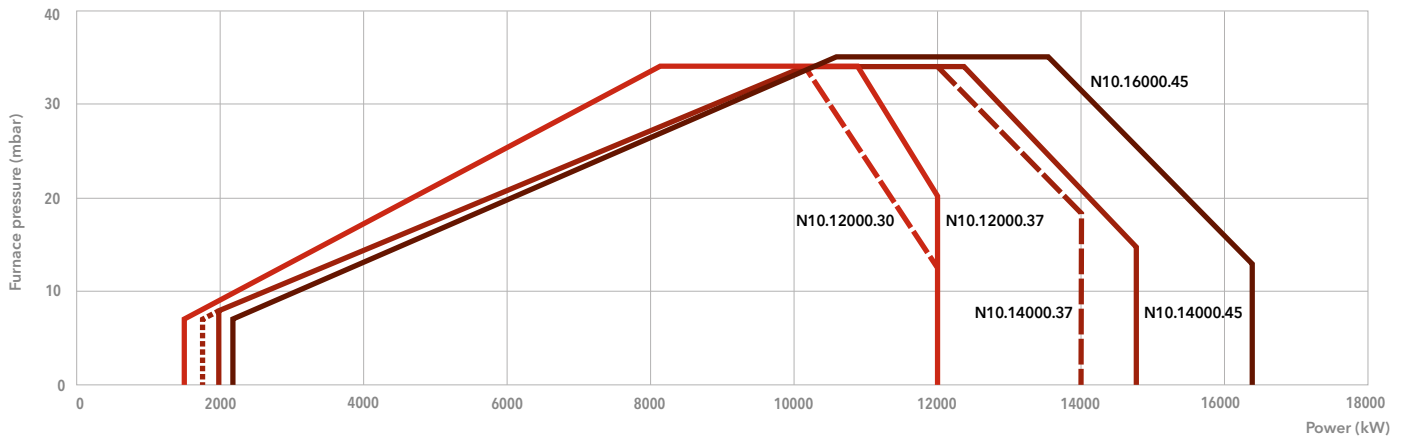

- **Fuels:** natural gas, Hi = 6,99 ... 11,39 kWh/m³
- **Emission class:** Low NO_x class 3 (≤80 mg/kWh) according to EN676
- **Additional configuration:** models with FGR System (≤30 mg/kWh) available on request
- **Protection level:** IP 40 (IP 51 as option)

TECHNICAL DATA

	N10.12000.30 G-EU2	N10.12000.37 G-EU2	N10.14000.37 G-EU2	N10.14000.45 G-EU2	N10.16000.45 G-EU2
Operating range	1500 - 12300 kW	1500 - 12300 kW	2000* - 14000 kW (*: 1750 with FQe)	2000* - 14800 kW (*: 1750 with FQe)	2150 - 16350 kW
Gas connection	DN100	DN100	DN100	DN100	DN100
Control box / flame detector	Etamatic OEM / FFS 08	Etamatic OEM / FFS 08	Etamatic OEM / FFS 08	Etamatic OEM / FFS 08	Etamatic OEM / FFS 08
Fan motor	50/60 Hz - 30 kW	50/60 Hz - 37 kW	50/60 Hz - 37 kW	50/60 Hz - 45 kW	50/60 Hz - 45 kW
Acoustic level	< 94 dB(A)	< 95 dB(A)	< 95 dB(A)	< 96 dB(A)	< 96 dB(A)
Complete burner code	on request	on request	on request	on request	on request

FQe = external frequency converter

GAS TRAINS

Gas inlet from the left side

Model	Code
s DN80-DN100	3757950
s DN100-DN100	3758623
s DN125-DN100	3760344
s DN150-DN100	3761042

Gas inlet from the right side

Model	Code
s DN80-DN100	3758624
s DN100-DN100	3757952
s DN125-DN100	3761040
s DN150-DN100	3761041

FILTERS

Model	Code
FG-DN80	3757201
FG-DN100	3757195
FG-DN125	3757209
FG-DN150	3757210



Pressure drops graphs: see following pages
Dimensions of gas trains and gas filters: see page 312



DIMENSIONS (mm)

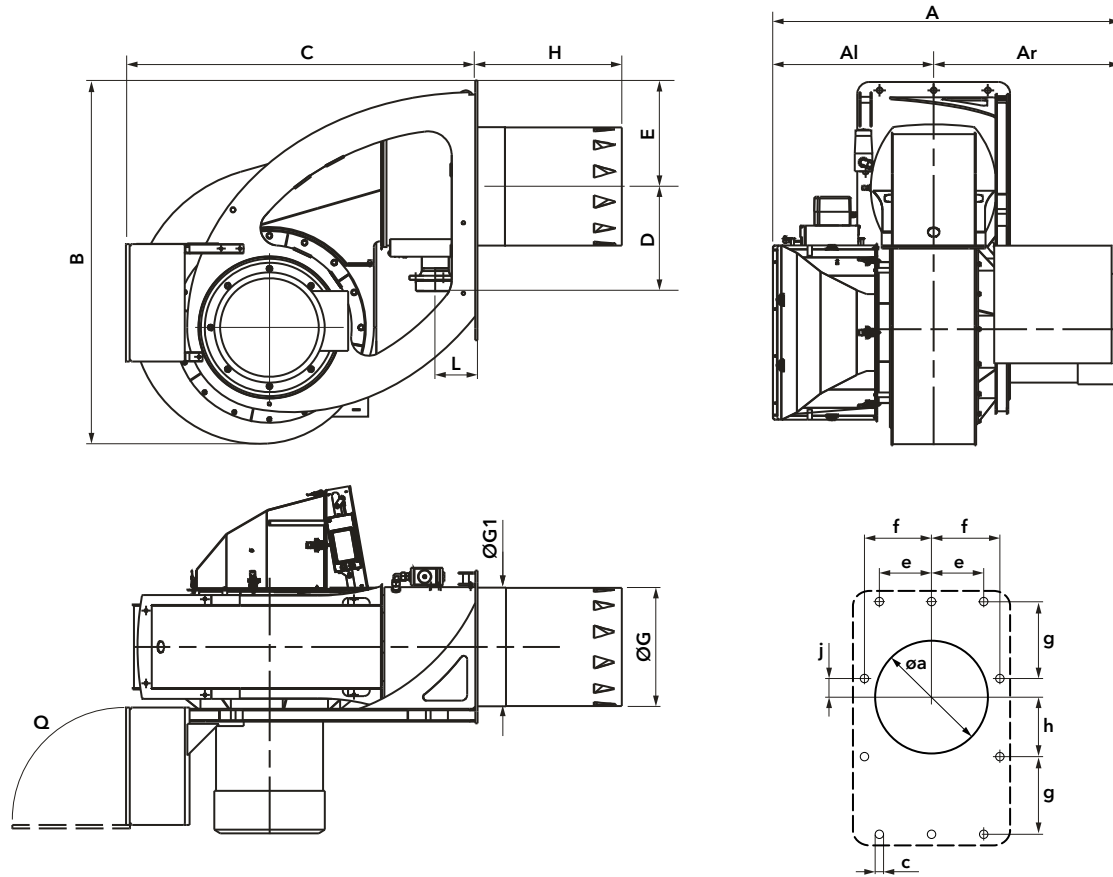

Model	A	Al	Ar	B	C	D	E	ØG	ØG1	H	L	Q	Øa	c	e	f	g	h	j
N10.12000.30 G-EU2	1441	683	758	1545	1494	446	450	497	504	620*	180	800	525	M20	230	290	345	275	70
N10.12000.37 G-EU2	1441	683	758	1545	1494	446	450	497	504	620*	180	800	525	M20	230	290	345	275	70
N10.14000.37 G-EU2	1441	683	758	1545	1494	446	450	497	504	620*	180	800	525	M20	230	290	345	275	70
N10.14000.45 G-EU2	1530	683	847	1545	1494	446	450	497	504	620*	180	800	525	M20	230	290	345	275	70
N10.16000.45 G-EU2	1530	683	847	1545	1494	446	450	497	504	620*	180	800	525	M20	230	290	345	275	70

*: different length on request

PACKAGING

The burner is delivered on a pallet with:

- burner body with mounted combustion head
- gas train and filter
- boiler fixing accessories
- technical documentation

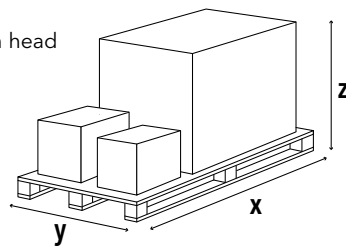

Model	Dimensions (mm)			Gross weight (kg)
	X	Y	Z	
N10... G-EU2	2200	1800	1900	1000

N10 G-EU2

1500 ... 16350 kW

Two stage progressive/modulating electronic

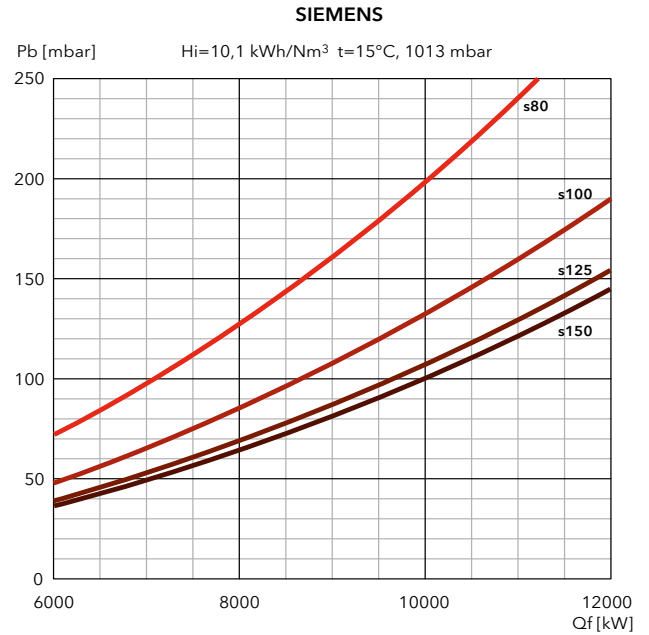
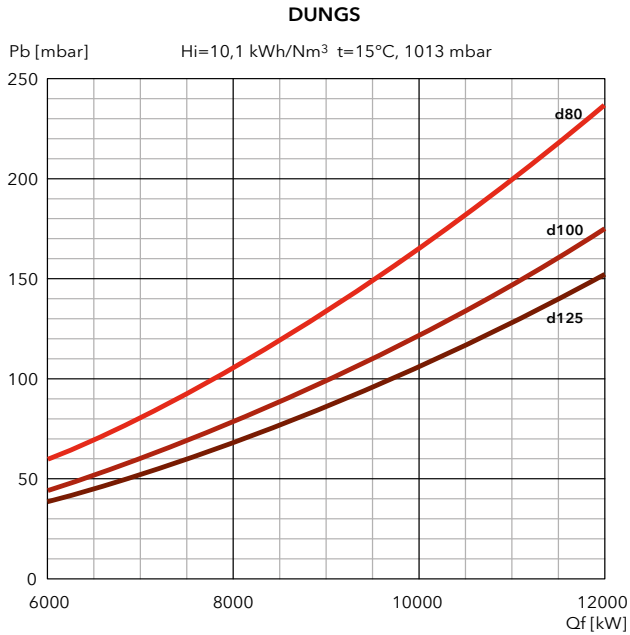
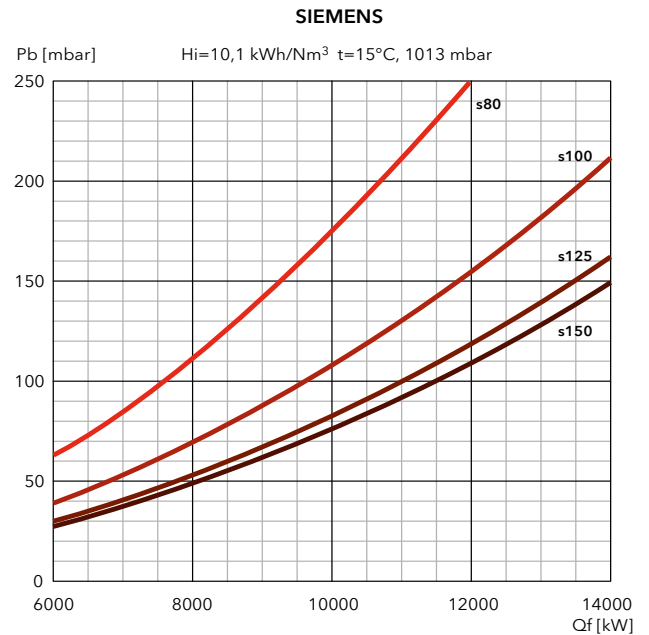
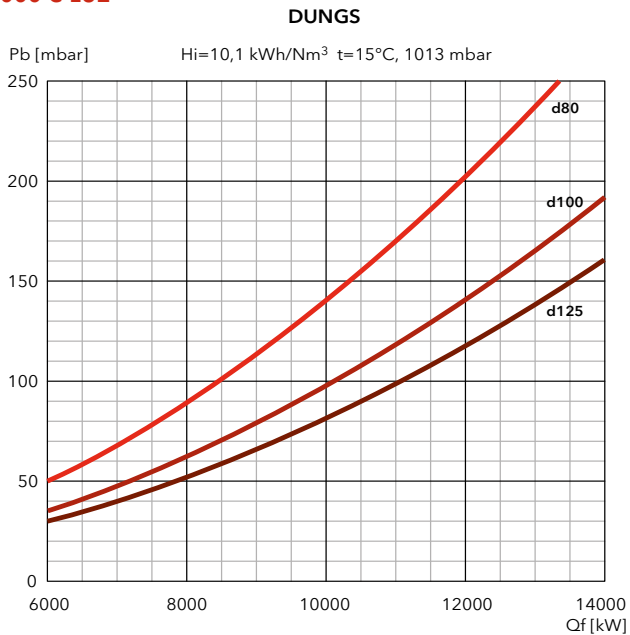
PRESSURE LOSS [BURNER HEAD + GAS TRAIN] (mbar)**N10.12000 G-EU2****N10.14000 G-EU2**

PRESSURE LOSS [BURNER HEAD + GAS TRAIN] (mbar)

N10.16000 G-EU2

DUNGS

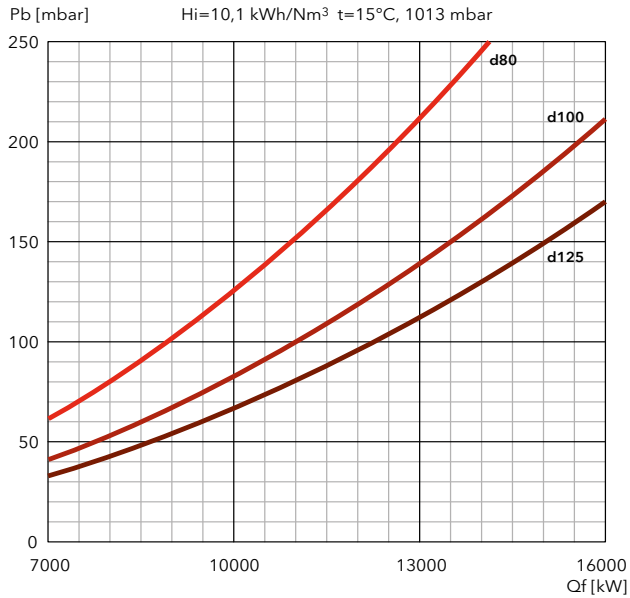

SIEMENS

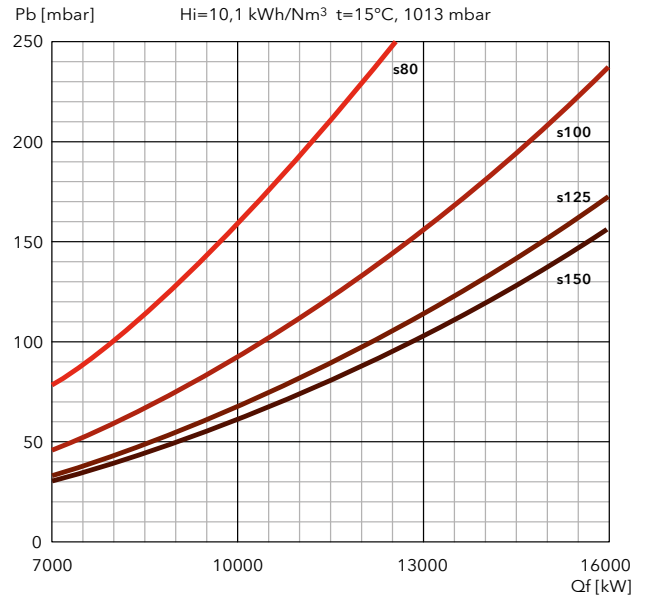

FILTERS

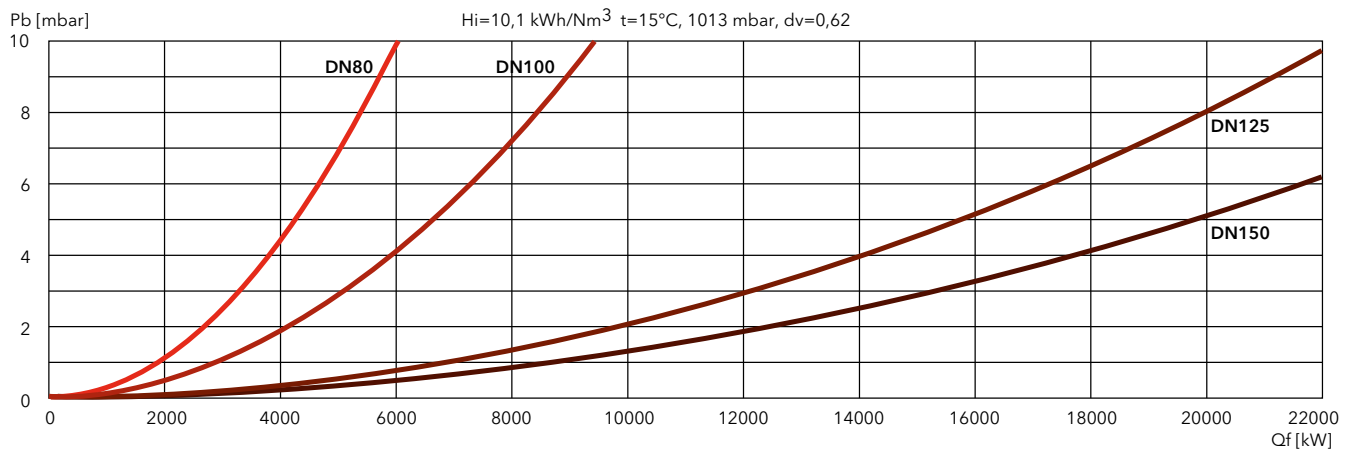

N

GAS

Low NO_x Class 3**N11 G-EU2**

2750 ... 22000 kW

Two stage progressive/modulating electronic

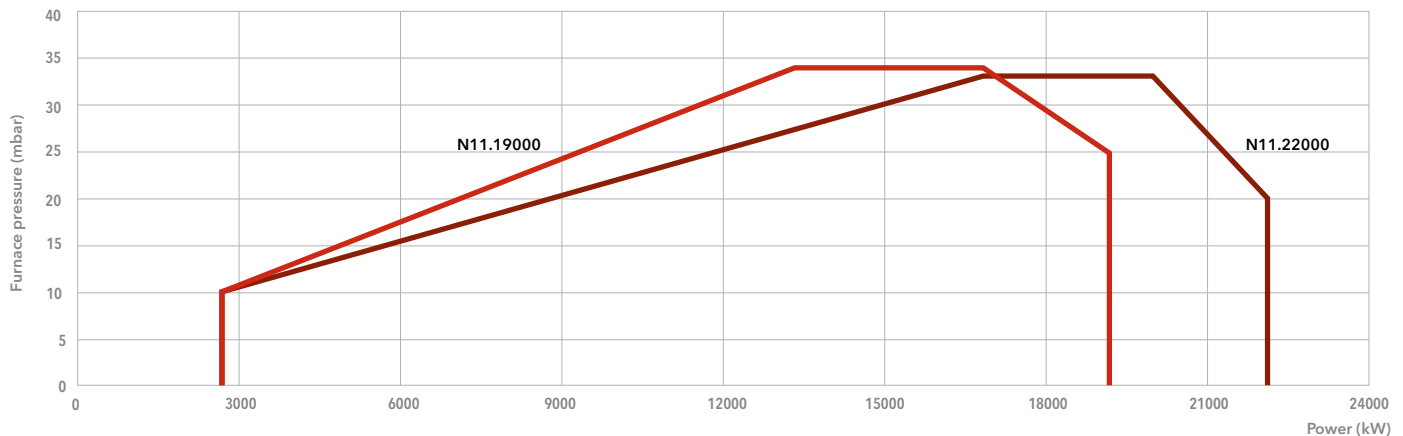

- **Fuels:** natural gas, Hi = 6,99 ... 11,39 kWh/m³
- **Emission class:** Low NO_x class 3 (≤80 mg/kWh) according to EN676
- **Additional configuration:** models with FGR System (≤30 mg/kWh) available on request
- **Protection level:** IP 40 (IP 54 as option)

TECHNICAL DATA

	N11.19000.55 G-EU2	N11.22000.75 G-EU2
Operating range	2750 - 19000 kW	2750 - 22000 kW
Gas connection	DN125	DN125
Control box / flame detector	Etamatic OEM / FFS 08	Etamatic OEM / FFS 08
Fan motor	50/60 Hz - 55 kW	50/60 Hz - 75 kW
Acoustic level	< 96,5 dB(A)	< 96,5 dB(A)
Complete burner code	on request	on request

GAS TRAINS

Gas inlet from the left side

Model	Code
s DN100-DN100	3761110
s DN125-DN100	3761111
s DN150-DN100	3761112

Gas inlet from the right side

Model	Code
s DN100-DN100	3761107
s DN125-DN100	3761108
s DN150-DN100	3761109

FILTERS

Model	Code
FG-DN100	3757195
FG-DN125	3757209
FG-DN150	3757210

i **Pressure drops graphs:** see following pages
Dimensions of gas trains and gas filters: see page 313



DIMENSIONS (mm)

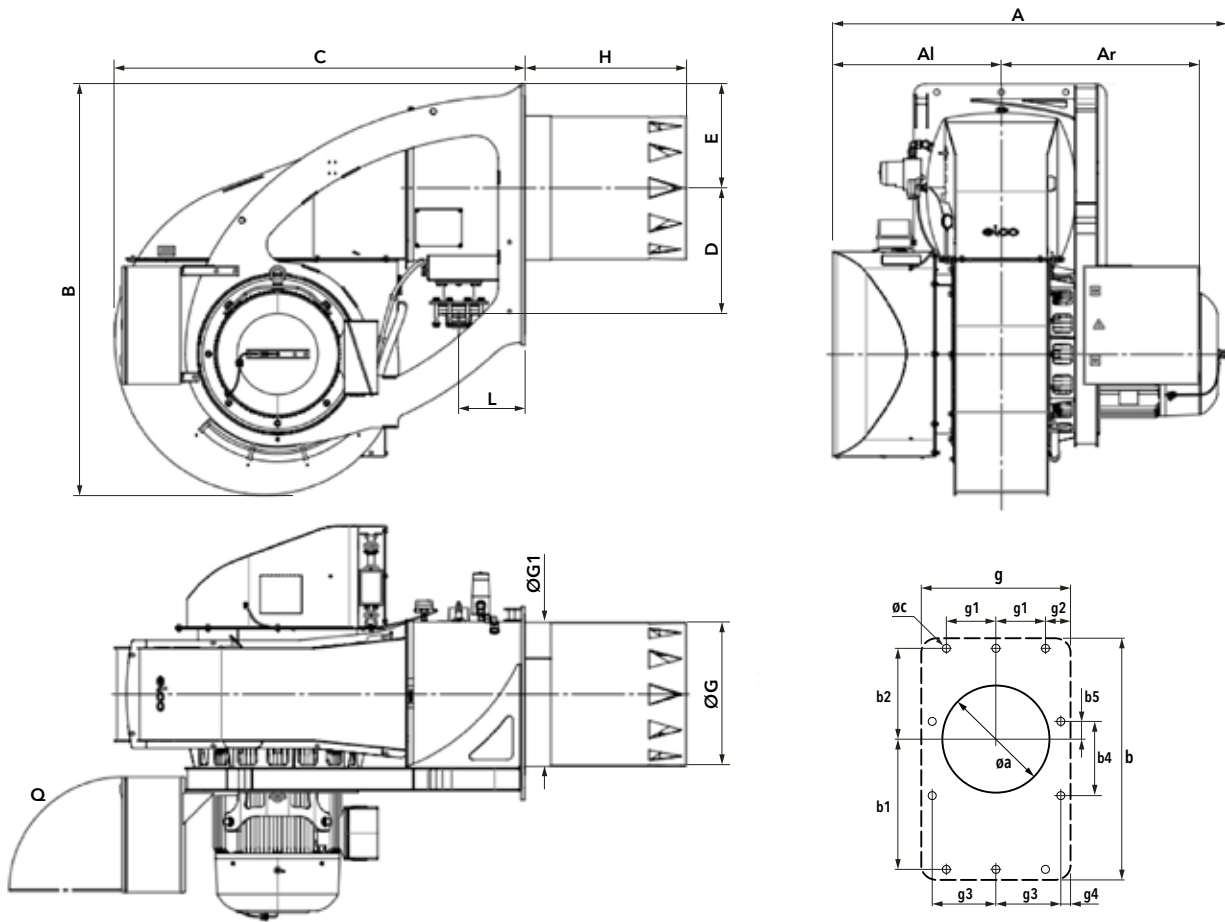

Model	A	Al	Ar	B	C	D	E	ØG	ØG1	H			L	Q	Øa	b	b1	b2	b4	b5	c	g	g1	g2	g3	g4
										KN	KM	KL														
N11.19000	1636	730	858	1780	1777	543	450	617	624	700	850	1000	285	800	645	1130	645	415	345	45	M20	836	280	176	345	111
N11.22000	1709	730	858	1780	1777	543	450	617	624	700	850	1000	285	800	645	1130	645	415	345	45	M20	836	280	176	345	111

PACKAGING

The burner is delivered on a pallet with:

- burner body with mounted combustion head
- gas train and filter
- boiler fixing accessories
- technical documentation

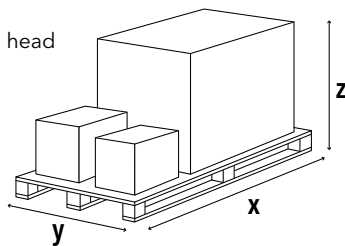

Model	Dimensions (mm)			Gross weight (kg)
	X	Y	Z	
N11... G-EU2	dimensions and weight depending on configuration			

N11 G-EU2

2750 ... 22000 kW

Two stage progressive/modulating electronic

PRESSURE LOSS [BURNER HEAD + GAS TRAIN] (mbar)

N11.19000 G-EU2

DUNGS

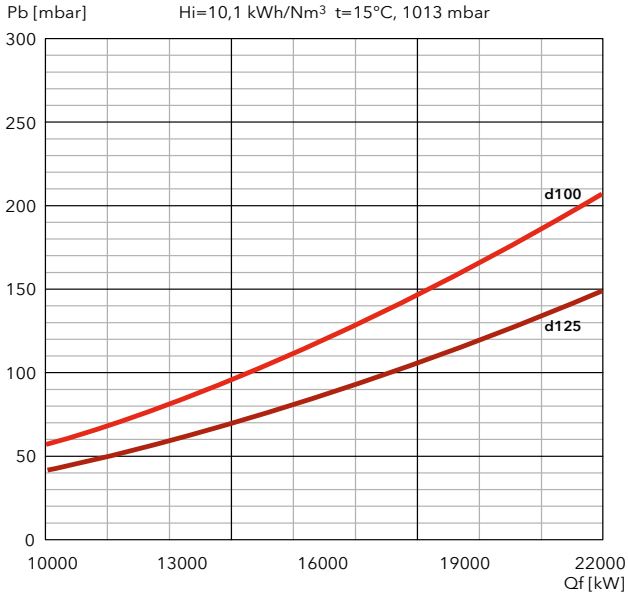

SIEMENS

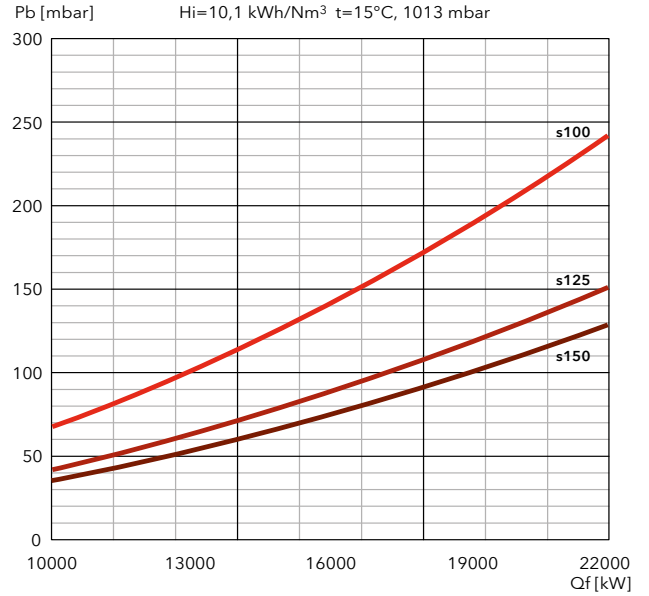

FILTERS

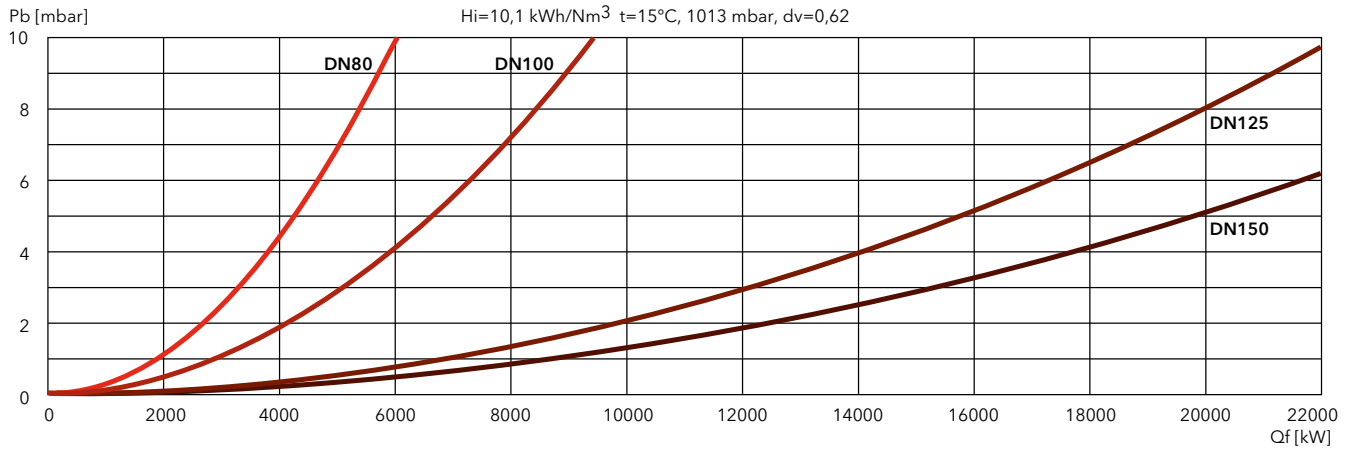

PRESSURE LOSS [BURNER HEAD + GAS TRAIN] (mbar)

N11.22000 G-EU2

DUNGS

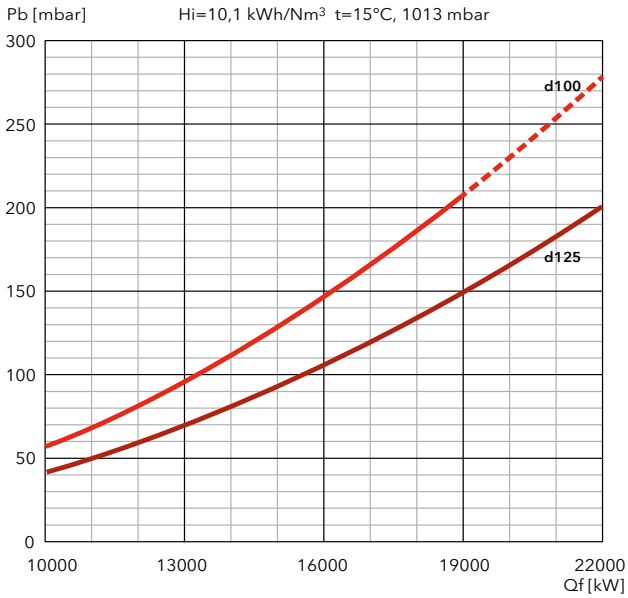

SIEMENS

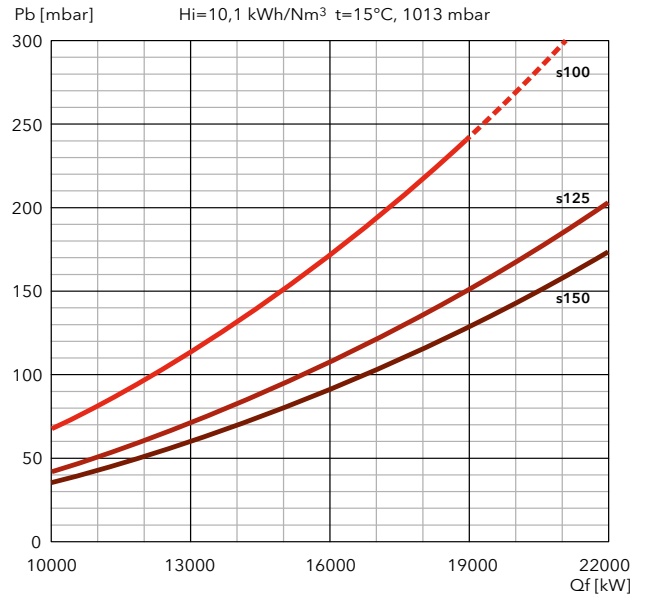

FILTERS

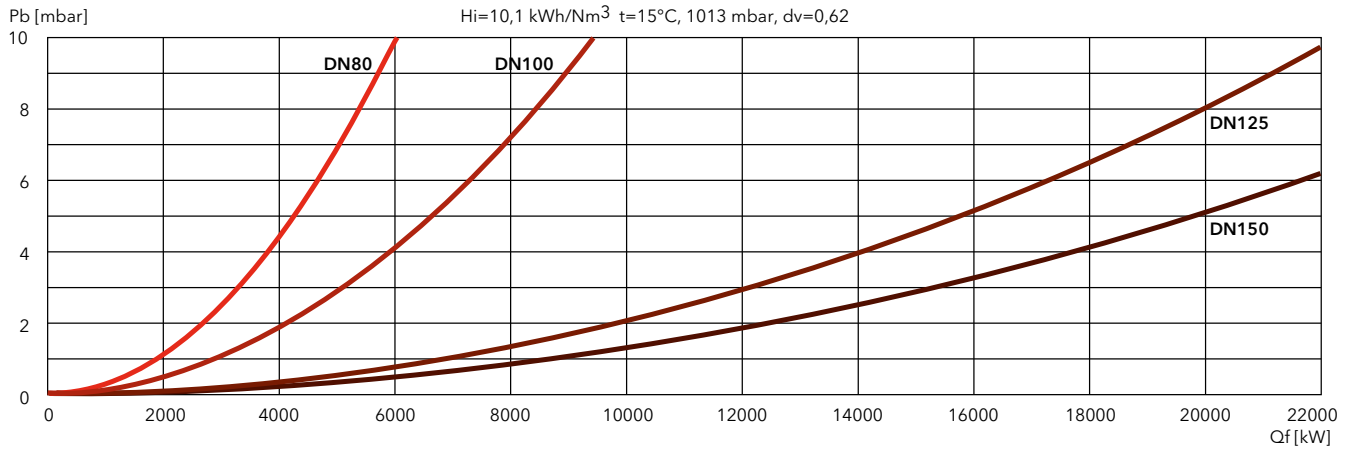

N

GAS

Low NO_x Class 2**N10 G-E**

1300 ... 16000 kW

Two stage progressive/modulating electronic

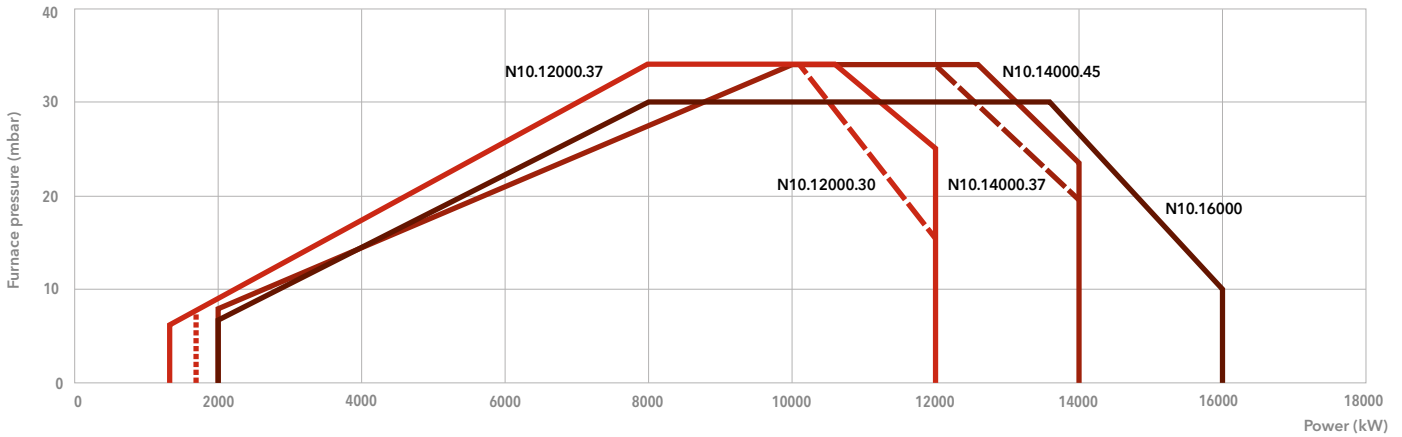

- **Fuels:** natural gas, Hi = 6,99 ... 11,39 kWh/m³
- **Emission class:** Low NO_x class 2 (≤120 mg/kWh) according to EN676
- **Protection level:** IP 54

TECHNICAL DATA

	N10.12000.30 G-E	N10.12000.37 G-E	N10.14000.37 G-E	N10.14000.45 G-E	N10.16000.45 G-E	N10.16000.55 G-E
Operating range	1750* - 12000 kW (*: 1300 with FQe)	1750* - 12000 kW (*: 1300 with FQe)	2000 - 14000 kW	2000 - 14000 kW	2000 - 16000 kW	2000 - 16000 kW
Gas connection	DN100	DN100	DN100	DN100	DN100	DN100
Control box / flame detector	Etamatic OEM / FFS 08	Etamatic OEM / FFS 08	Etamatic OEM / FFS 08	Etamatic OEM / FFS 08	Etamatic OEM / FFS 08	Etamatic OEM / FFS 08
Fan motor	50/60 Hz - 30 kW	50/60 Hz - 37 kW	50/60 Hz - 37 kW	50/60 Hz - 45 kW	50/60 Hz - 45 kW	50/60 Hz - 55 kW
Acoustic level	< 97 dB(A)	< 97 dB(A)	< 97 dB(A)	< 97 dB(A)	< 97 dB(A)	< 97 dB(A)
Complete burner code	on request	on request	on request	on request	on request	on request

FQe = external frequency converter

GAS TRAINS

Gas inlet from the left side

Model	Code
s DN80-DN100	3757950
s DN100-DN100	3758623
s DN125-DN100	3760344
s DN150-DN100	3761042

Gas inlet from the right side

Model	Code
s DN80-DN100	3758624
s DN100-DN100	3757952
s DN125-DN100	3761040
s DN150-DN100	3761041

FILTERS

Model	Code
FG-DN80	3757201
FG-DN100	3757195
FG-DN125	3757209
FG-DN150	3757210

i **Pressure drops graphs:** see following pages
Dimensions of gas trains and gas filters: see page 312

DIMENSIONS (mm)

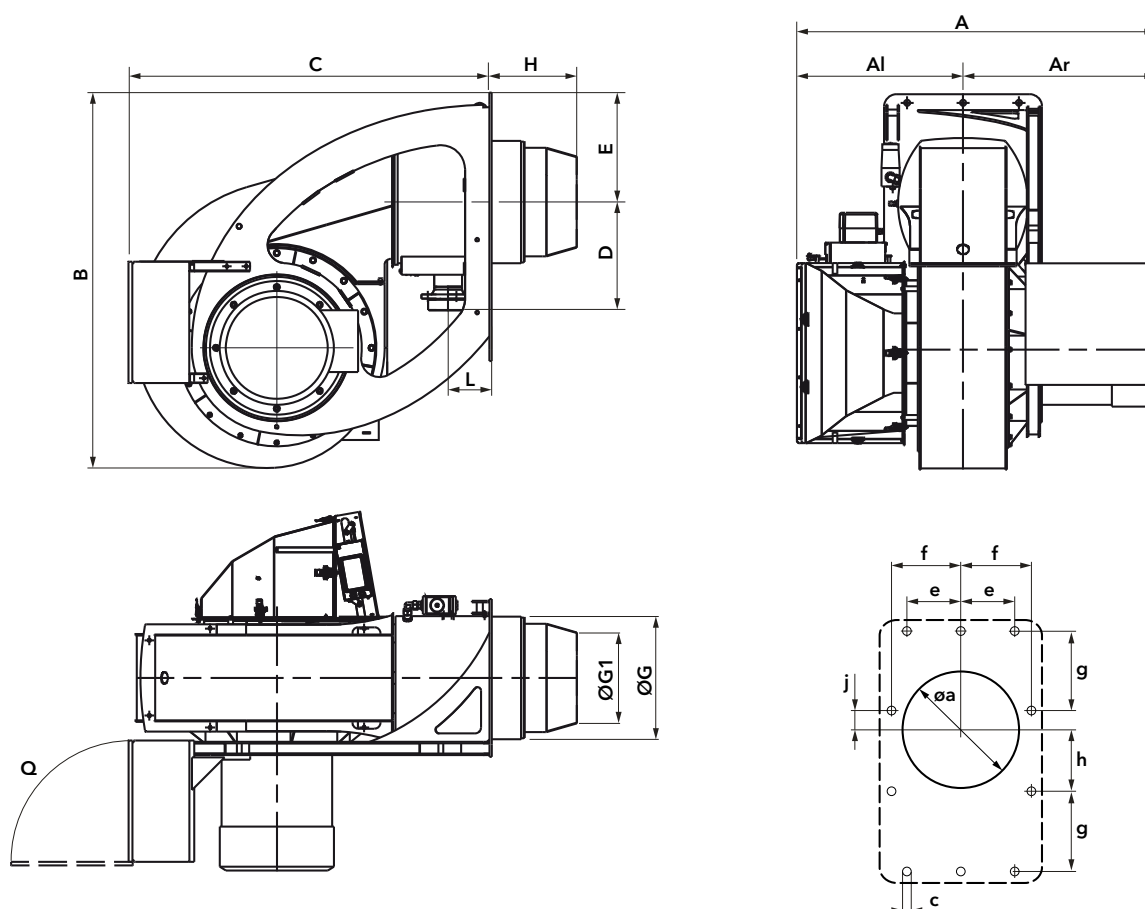

Model	A	Al	Ar	B	C	D	E	ØG	ØG1	H	L	Q	Øa	c	e	f	g	h	j
N10.12000... G-E	1441	683	758	1545	1494	446	450	504	375	350*	180	800	525	M20	230	290	345	275	70
N10.14000.37 G-E	1441	683	758	1545	1494	446	450	504	425	350*	180	800	525	M20	230	290	345	275	70
N10.14000.45 G-E	1530	683	847	1545	1494	446	450	504	425	350*	180	800	525	M20	230	290	345	275	70
N10.16000.45 G-E	1530	683	847	1545	1494	446	450	504	425	350*	180	800	525	M20	230	290	345	275	70
N10.16000.55 G-E	1560	683	877	1545	1494	446	450	504	425	350*	180	800	525	M20	230	290	345	275	70

*: different length on request

PACKAGING

The burner is delivered on a pallet with:

- burner body with mounted combustion head
- gas train and filter
- boiler fixing accessories
- technical documentation

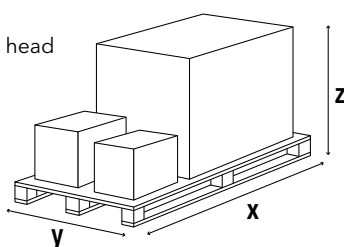

Model	Dimensions (mm)			Gross weight (kg)
	X	Y	Z	
N10... G-E	2200	1800	1900	1000

N10 G-E

1300 ... 16000 kW

Two stage progressive/modulating electronic

PRESSURE LOSS [BURNER HEAD + GAS TRAIN] (mbar)

N10.12000 G-E

DUNGS

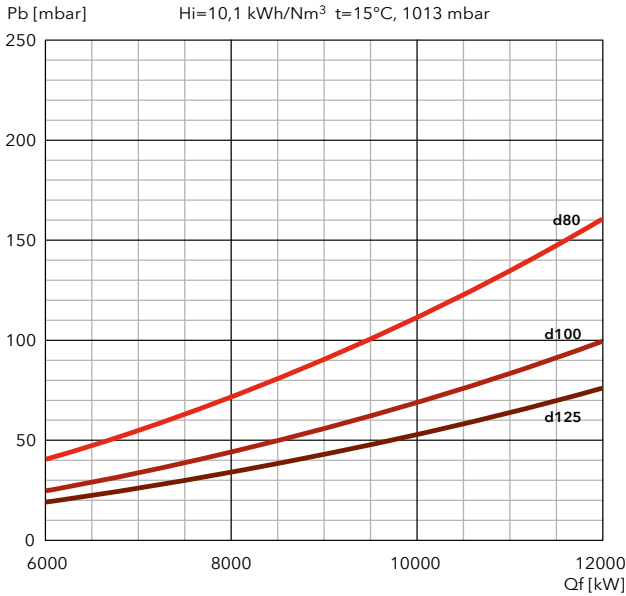

SIEMENS

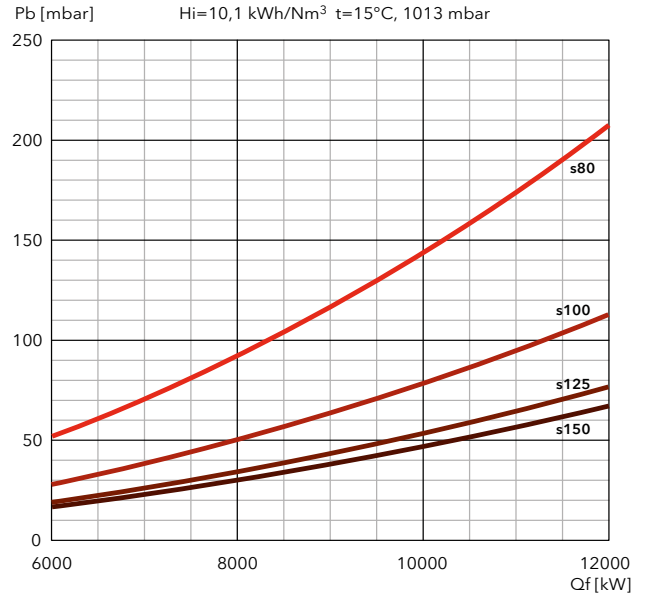

N10.14000 G-E

DUNGS

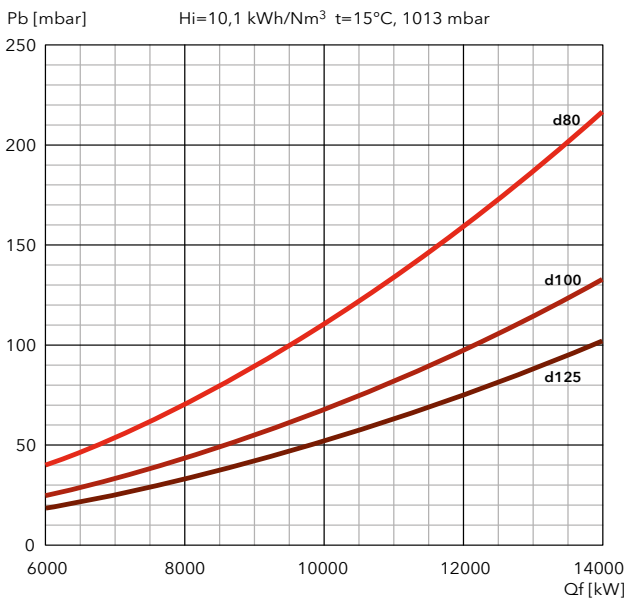

SIEMENS

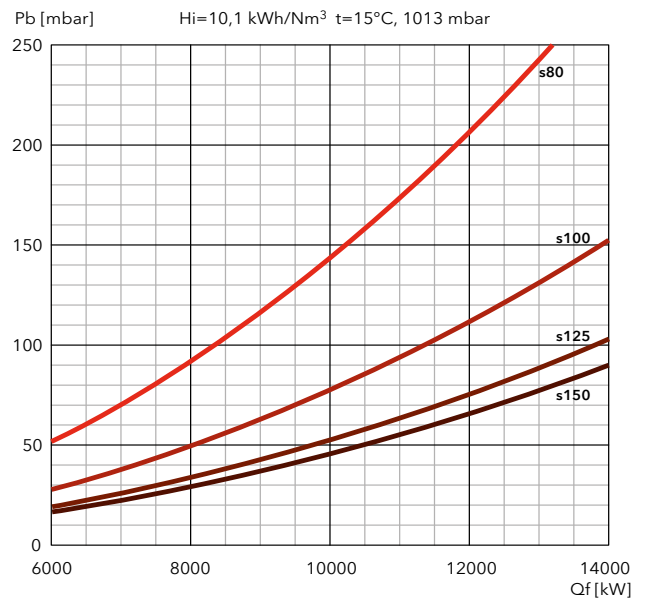



PRESSURE LOSS [BURNER HEAD + GAS TRAIN] (mbar)

N10.16000 G-E

DUNGS

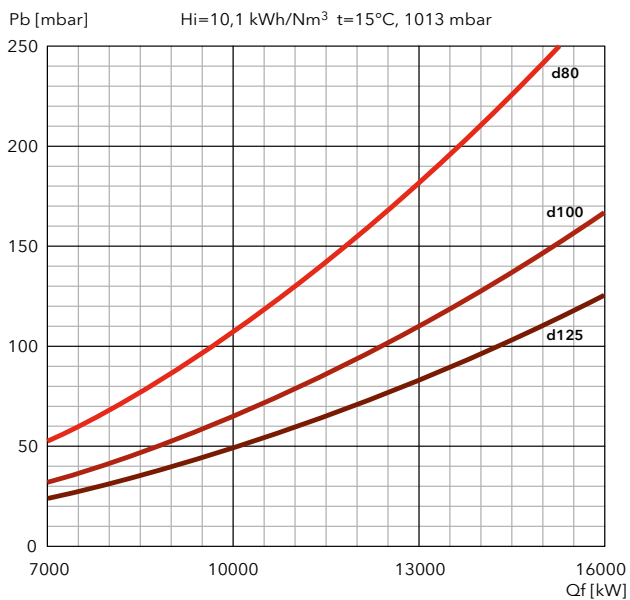

SIEMENS

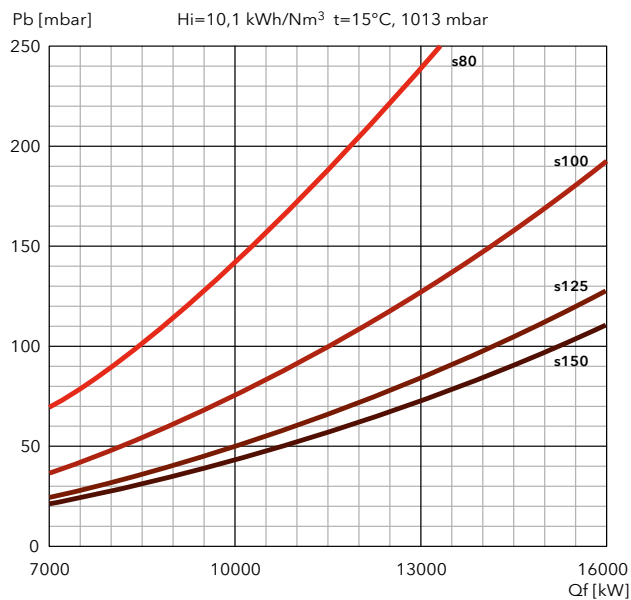

FILTERS

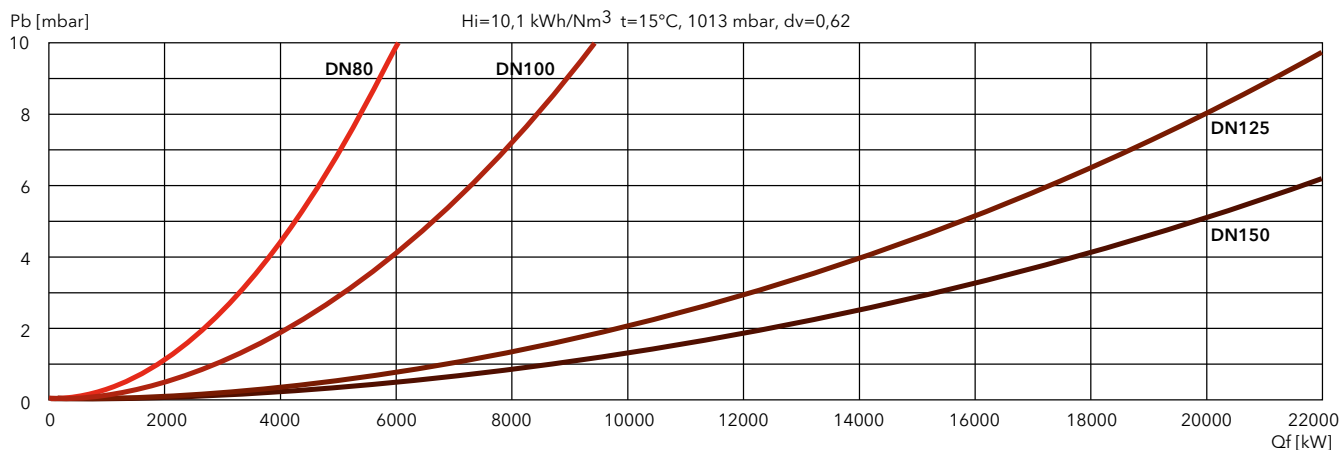

N10 GL-EUF

1400 ... 16250 kW

Two stage progressive/modulating electronic in gas and in light oil

- **Fuels:** natural gas, Hi = 6,99 ... 11,39 kWh/Nm³;
light oil, viscosity 6 mm²/s at 20°C, Hi = 11,86 kWh/kg
- **Emission class:** Low NOx class 3 (≤80 mg/kWh) according to EN676 in gas
Low NOx class 3 (≤120 mg/kWh) according to EN267 in light oil
- **Additional configuration:** models with FGR System (≤30 mg/kWh) available on request
- **Protection level:** IP 40 (IP 54 as option)

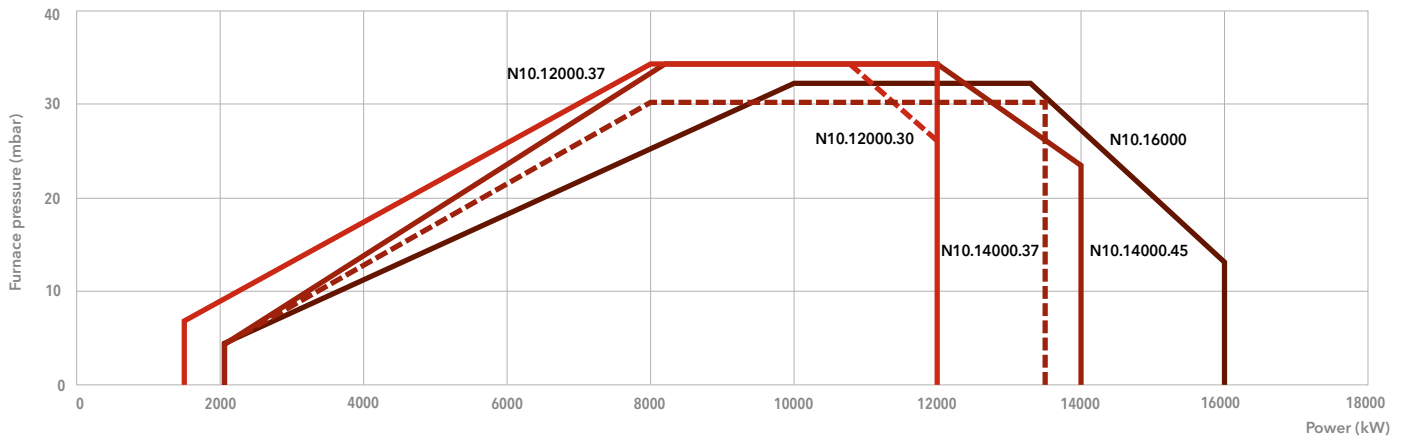
**TECHNICAL DATA**

	N10.12000.30 GL-EUF	N10.12000.37 GL-EUF	N10.14000.37 GL-EUF	N10.14000.45 GL-EUF	N10.16000.45 GL-EUF
Operating range gas	1750* - 12000 kW (*: 1500 with FQe)	1750* - 12000 kW (*: 1500 with FQe)	2100 - 13500 kW	2100 - 14000 kW	2100 - 16000 kW
Operating range oil	3000 - 12000 kW	3000 - 12000 kW	3300 - 13500 kW	3300 - 14000 kW	3300 - 16000 kW
Gas connection	DN100	DN100	DN100	DN100	DN100
Control box / flame detector	Etamatic OEM / FFS 08	Etamatic OEM / FFS 08	Etamatic OEM / FFS 08	Etamatic OEM / FFS 08	Etamatic OEM / FFS 08
Fan motor	50/60 Hz - 30 kW	50/60 Hz - 37 kW	50/60 Hz - 37 kW	50/60 Hz - 45 kW	50/60 Hz - 45 kW
Pump	2200 l/h - 4 kW	2200 l/h - 4 kW	2200 l/h - 4 kW	2200 l/h - 4 kW	3600 l/h - 5,5 kW
Acoustic level	< 97 dB(A)	< 97 dB(A)	< 97 dB(A)	< 97 dB(A)	< 97 dB(A)
Complete burner code	on request	on request	on request	on request	on request

FQe = external frequency converter

GAS TRAINS

Gas inlet from the left side

Model	Code
s DN80-DN100	3757950
s DN100-DN100	3758623
s DN125-DN100	3760344
s DN150-DN100	3761042

Gas inlet from the right side

Model	Code
s DN80-DN100	3758624
s DN100-DN100	3757952
s DN125-DN100	3761040
s DN150-DN100	3761041

FILTERS

Model	Code
FG-DN80	3757201
FG-DN100	3757195
FG-DN125	3757209
FG-DN150	3757210

i Pressure drops graphs: see following pages
Dimensions of gas trains and gas filters: see page 312



DIMENSIONS (mm)

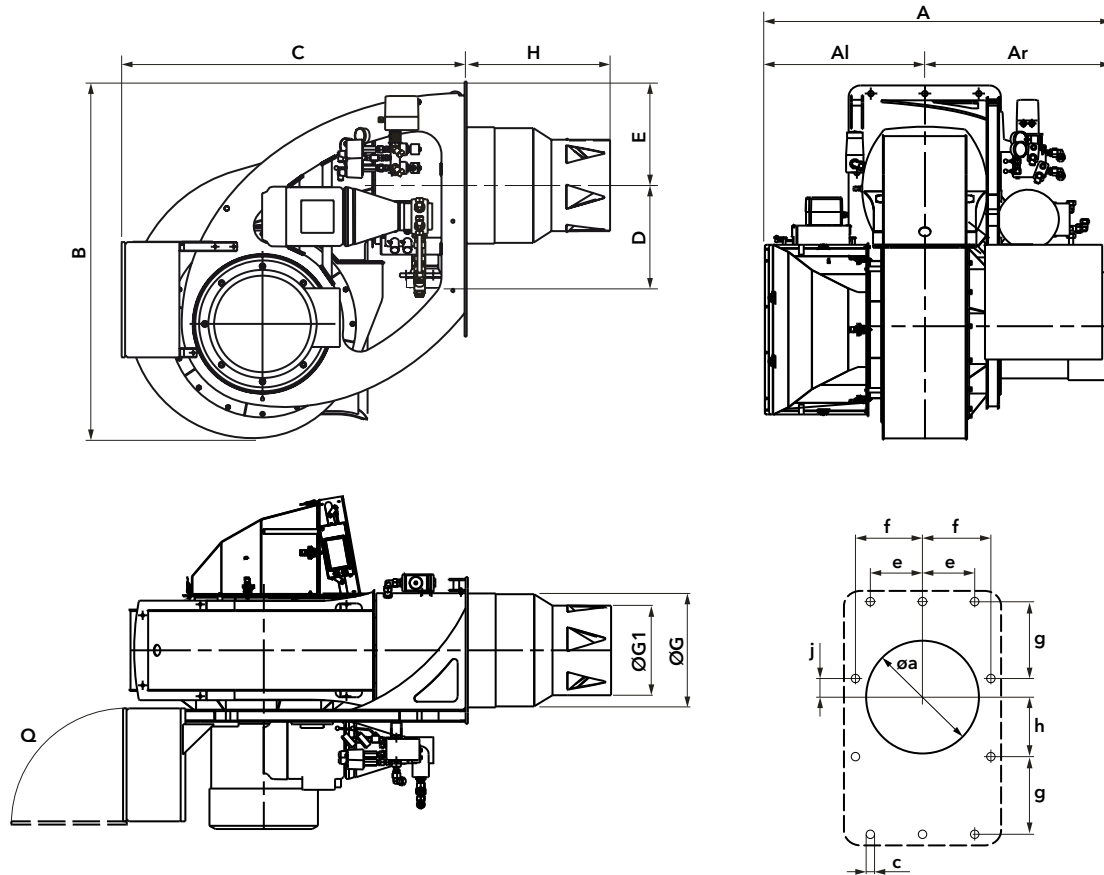

Model	A	Al	Ar	B	C	D	E	ØG	ØG1	H	L	Q	Øa	c	e	f	g	h	j
N10.12000.30 GL-EUF	1441	683	758	1545	1494	446	450	504	396	620*	180	800	525	M20	230	290	345	275	70
N10.12000.37 GL-EUF	1441	683	758	1545	1494	446	450	504	396	620*	180	800	525	M20	230	290	345	275	70
N10.14000.37 GL-EUF	1441	683	758	1545	1494	446	450	504	436	620*	180	800	525	M20	230	290	345	275	70
N10.14000.45 GL-EUF	1530	683	847	1545	1494	446	450	504	436	620*	180	800	525	M20	230	290	345	275	70
N10.16000.45 GL-EUF	1530	683	847	1545	1494	446	450	504	436	620*	180	800	525	M20	230	290	345	275	70

*: different length on request

PACKAGING

The burner is delivered on a pallet with:

- burner body with mounted combustion head
- gas train and filter
- boiler fixing accessories
- technical documentation

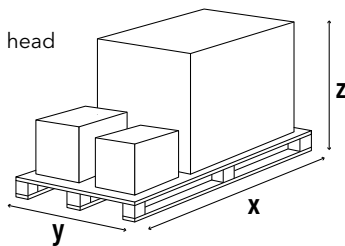

Model	Dimensions (mm)			Gross weight (kg)
	X	Y	Z	
N10... GL-EUF	2200	1800	1900	1000

N10 GL-EUF

1400 ... 16250 kW

Two stage progressive/modulating electronic in gas and in light oil

PRESSURE LOSS [BURNER HEAD + GAS TRAIN] (mbar)

N10.12000 GL-EUF

DUNGS

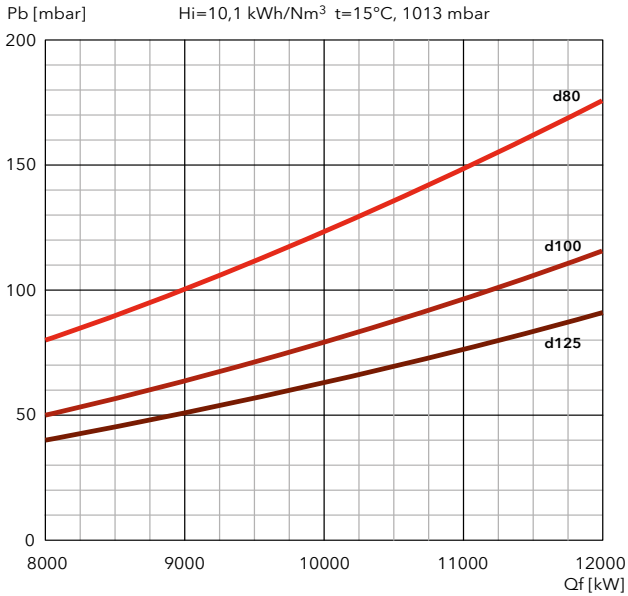

SIEMENS

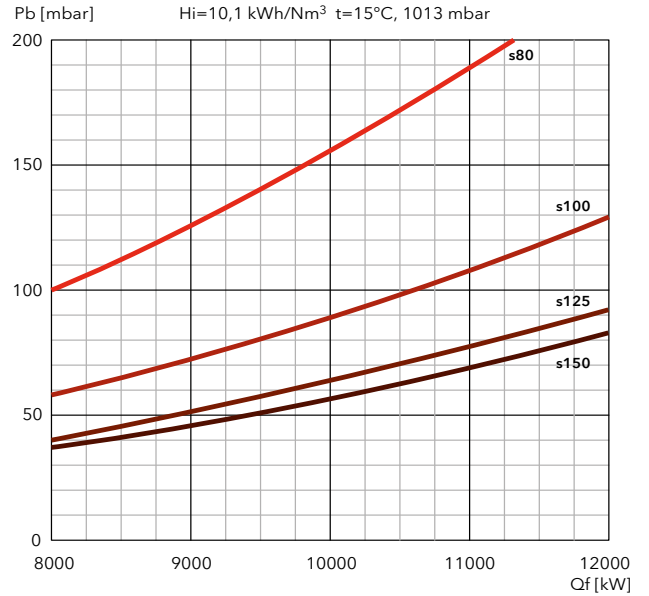

N10.14000 GL-EUF

DUNGS

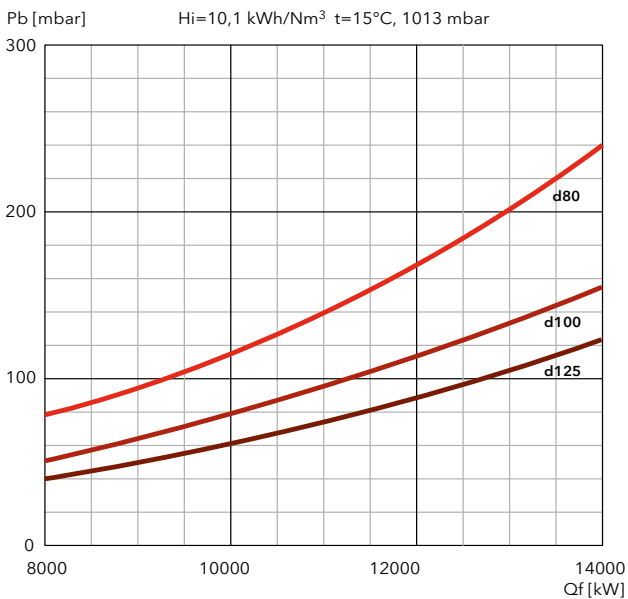

SIEMENS

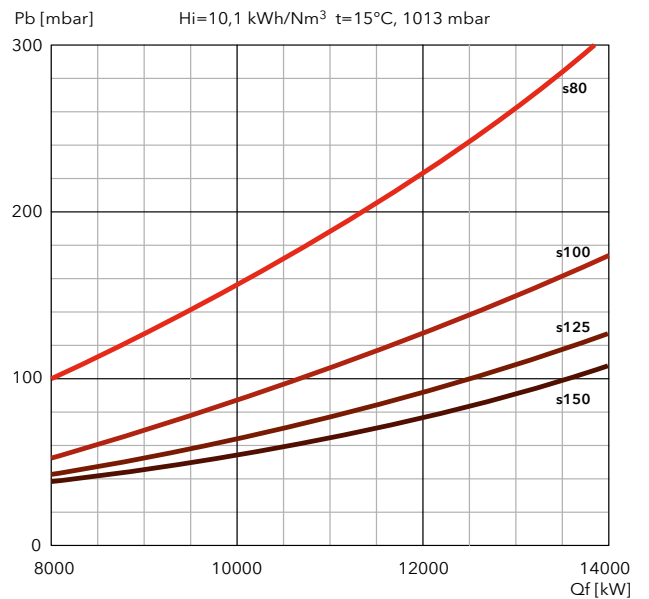



PRESSURE LOSS [BURNER HEAD + GAS TRAIN] (mbar)

N10.16000 GL-EUF

DUNGS

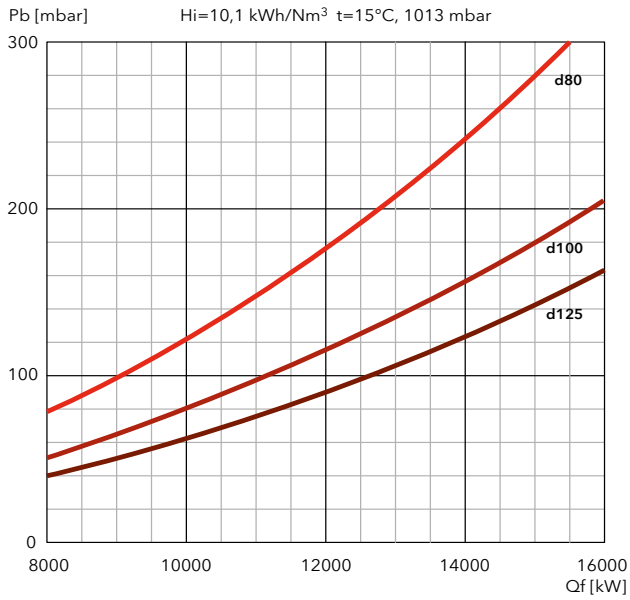

SIEMENS

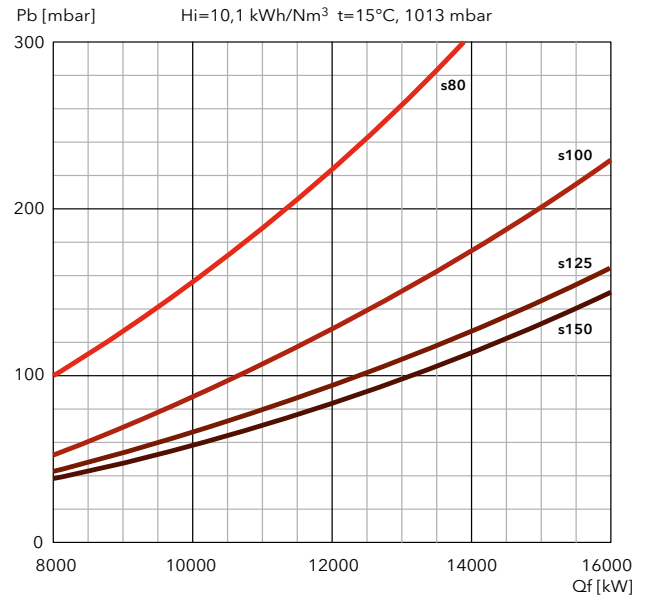

FILTERS

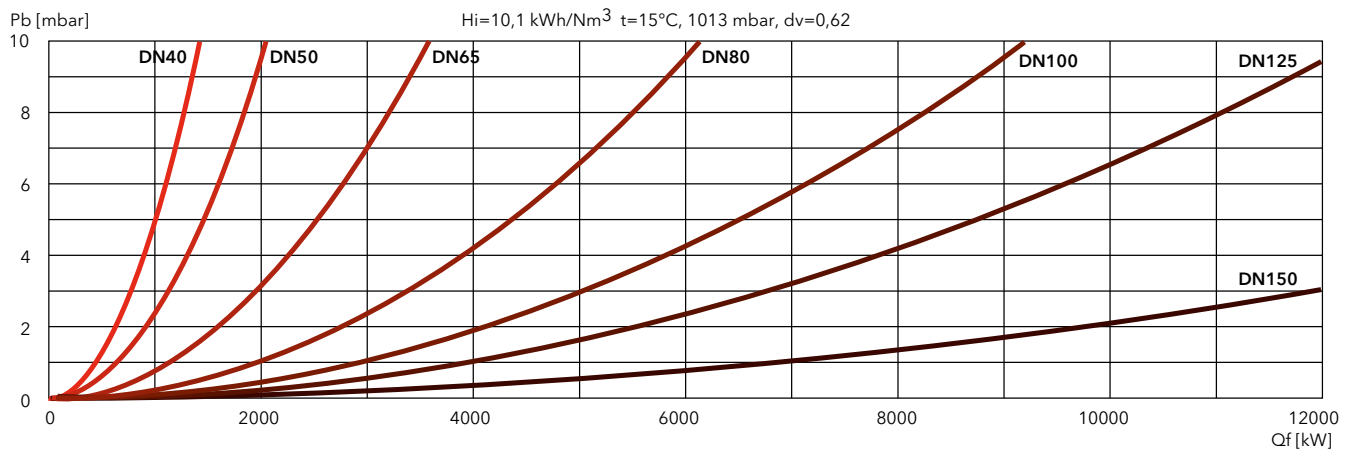

N10 GL-E

1300 ... 12000 kW

Two stage progressive/modulating electronic in gas and in light oil

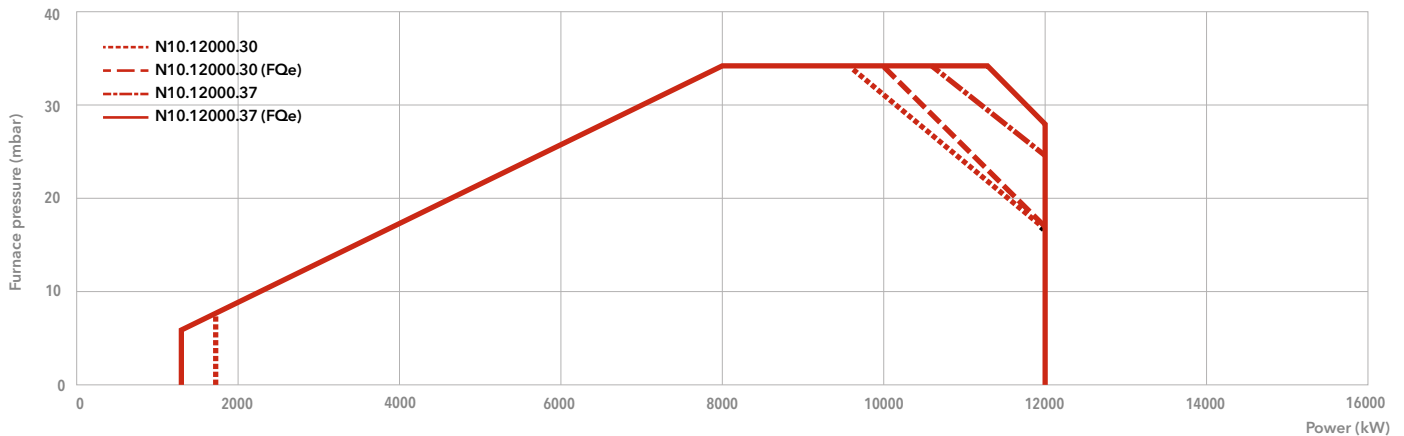

- **Fuels:** natural gas, Hi = 6,99 ... 11,39 kWh/Nm³;
light oil, viscosity 6 mm²/s at 20°C, Hi = 11,86 kWh/kg
- **Emission class:** Low NO_x class 2 (≤120 mg/kWh) according to EN676 in gas
Low NO_x class 2 (≤185 mg/kWh) according to EN267 in light oil
- **Protection level:** IP 54

TECHNICAL DATA

FQe = external frequency converter

	N10.12000.30 GL-E	N10.12000.37 GL-E
Operating range gas	1300* - 12000 kW (*: 1750 without FQ)	1300* - 12000 kW (*: 1750 without FQ)
Operating range oil	3600 - 12000 kW	3600 - 12000 kW
Gas connection	DN100	DN100
Control box / flame detector	Etamatic OEM / FFS 08	Etamatic OEM / FFS 08
Fan motor	50/60 Hz - 30 kW	50/60 Hz - 37 kW
Pump	2700 l/h - 4 kW	2700 l/h - 4 kW
Acoustic level	< 97 dB(A)	< 97 dB(A)
Complete burner code	on request	on request

GAS TRAINS

Gas inlet from the left side

Model	Code
s DN80-DN100	3757950
s DN100-DN100	3758623
s DN125-DN100	3760344
s DN150-DN100	3761042

Gas inlet from the right side

Model	Code
s DN80-DN100	3758624
s DN100-DN100	3757952
s DN125-DN100	3761040
s DN150-DN100	3761041

FILTERS

Model	Code
FG-DN80	3757201
FG-DN100	3757195
FG-DN125	3757209
FG-DN150	3757210

i Pressure drops graphs: see following pages
Dimensions of gas trains and gas filters: see page 312

DIMENSIONS (mm)

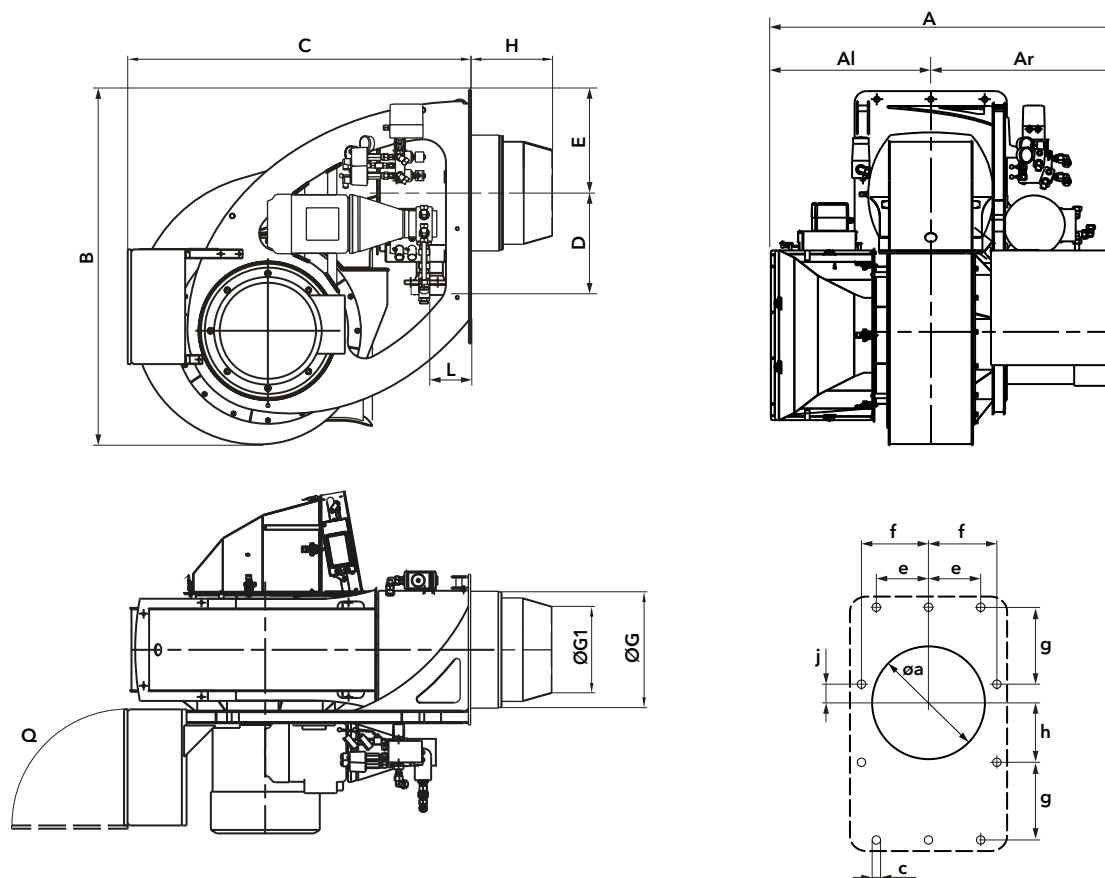

Model	A	Al	Ar	B	C	D	E	ØG	ØG1	H	L	Q	Øa	c	e	f	g	h	j
N10.12000.30 GL-E	1441	683	758	1545	1494	446	450	504	375	350*	180	800	525	M20	230	290	345	275	70
N10.12000.37 GL-E	1441	683	758	1545	1494	446	450	504	375	350*	180	800	525	M20	230	290	345	275	70

*: different length on request

PACKAGING

The burner is delivered on a pallet with:

- burner body with mounted combustion head
- gas train and filter
- boiler fixing accessories
- technical documentation

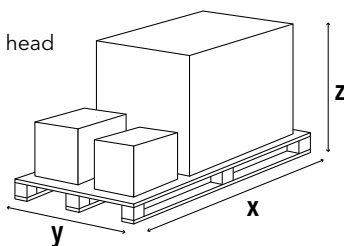

Model	Dimensions (mm)			Gross weight (kg)
	X	Y	Z	
N10... GL-E	2200	1800	1900	1000

N10 GL-E

1300 ... 12000 kW

Two stage progressive/modulating electronic in gas and in light oil

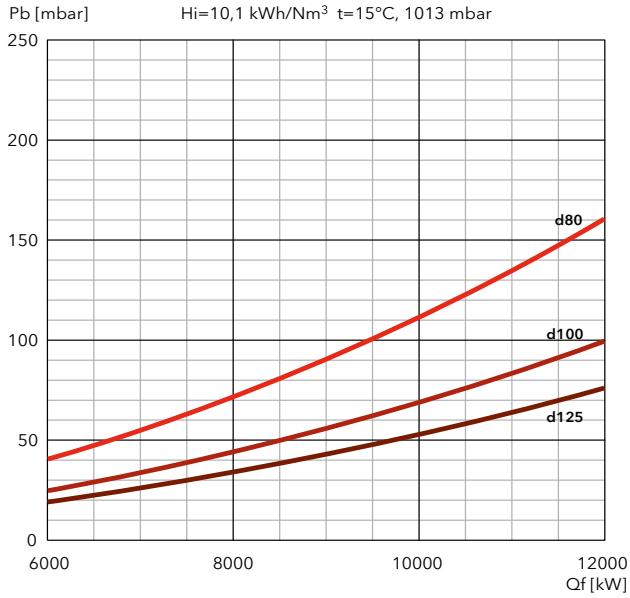
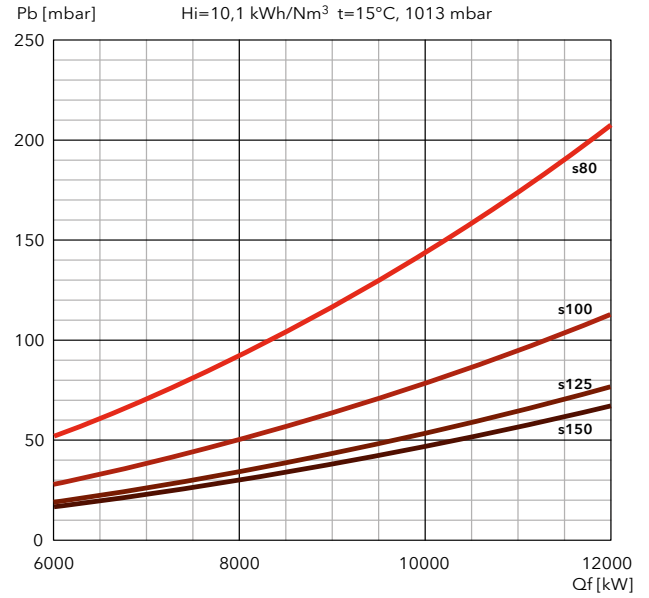
PRESSURE LOSS [BURNER HEAD + GAS TRAIN] (mbar)**N10.12000 GL-E****DUNGS****SIEMENS**



PRESSURE LOSS [BURNER HEAD + GAS TRAIN] (mbar)

FILTERS

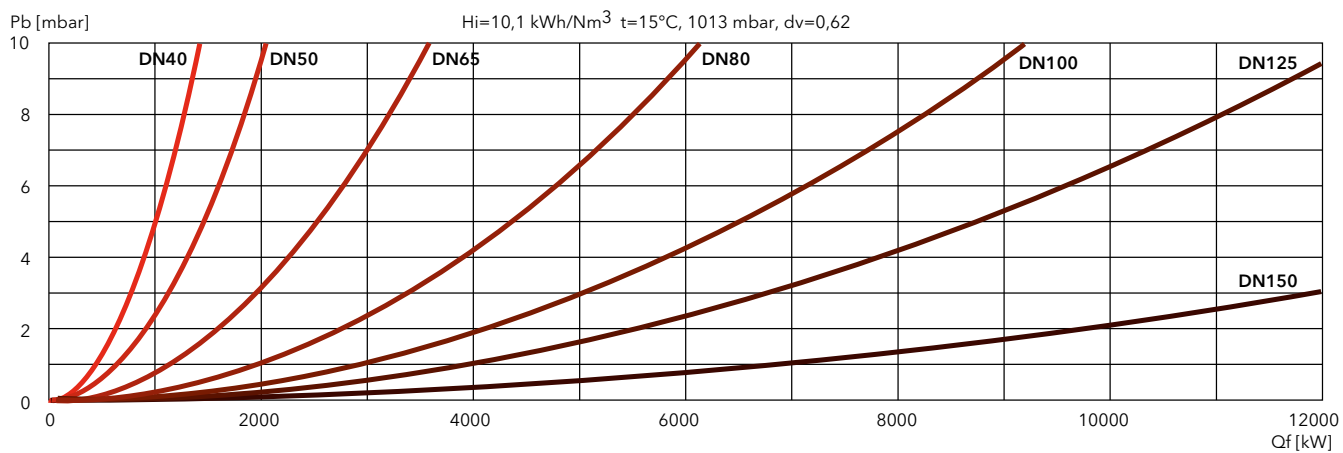

N

LIGHT OIL

Low NOx Class 3

N10 L-EUF

3000 ... 16670 kW

Two stage progressive/modulating electronic

- **Fuels:** light oil, viscosity 6 mm²/s at 20°C, Hi = 11,86 kWh/kg
- **Emission class:** Low NOx class 3 (≤120 mg/kWh) according to EN267
- **Protection level:** IP 40 (IP 54 as option)

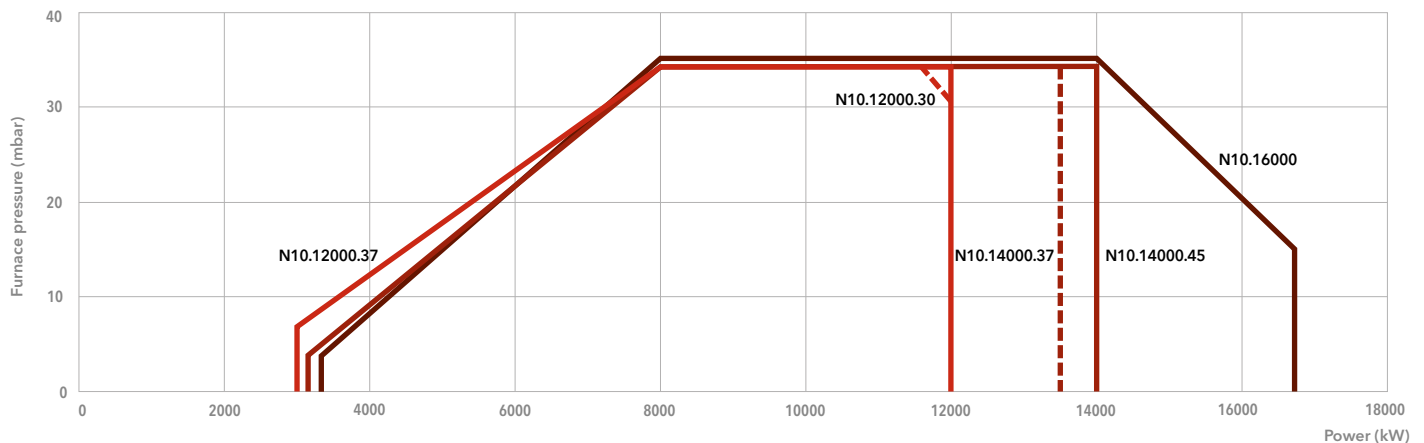
**TECHNICAL DATA**

FOe = external frequency converter

	N10.12000.30 L-EUF	N10.12000.37 L-EUF	N10.14000.37 L-EUF	N10.14000.45 L-EUF	N10.16000.45 L-EUF
Operating range	3000 – 12000 kW	3000 – 12000 kW	3150 – 13500 kW	3150 – 14000 kW	3300 – 16670 kW
Control box / flame detector	Etamatic OEM / FFS 08	Etamatic OEM / FFS 08	Etamatic OEM / FFS 08	Etamatic OEM / FFS 08	Etamatic OEM / FFS 08
Fan motor	50/60 Hz – 30 kW	50/60 Hz – 37 kW	50/60 Hz – 37 kW	50/60 Hz – 45 kW	50/60 Hz – 45 kW
Pump	2700 l/h – 4 kW	2700 l/h – 4 kW	2700 l/h – 4 kW	2700 l/h – 4 kW	2700 l/h – 4 kW
Acoustic level	< 97 dB(A)	< 97 dB(A)	< 97 dB(A)	< 97 dB(A)	< 97 dB(A)
Complete burner code	on request	on request	on request	on request	on request



DIMENSIONS (mm)

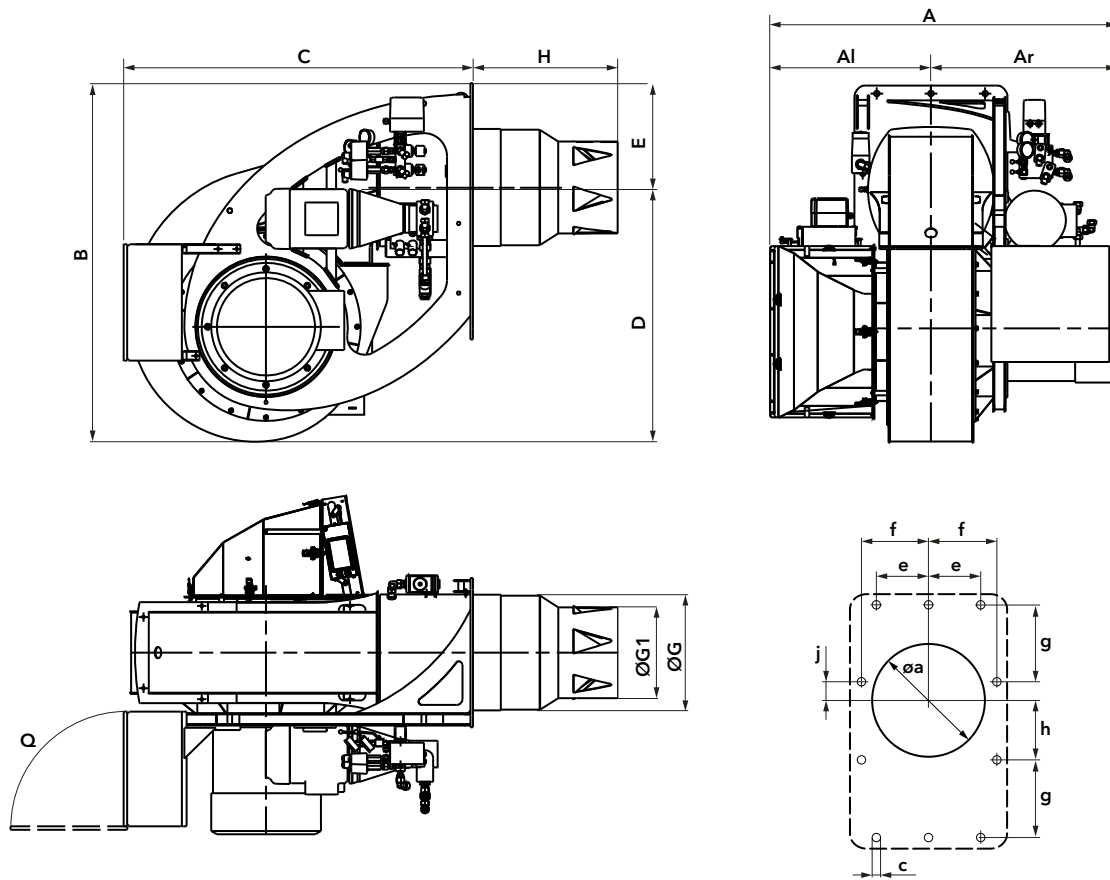

Model	A	Al	Ar	B	C	D	E	ØG	ØG1	H	Q	Øa	c	e	f	g	h	j
N10.12000.30 L-EUF	1441	683	758	1545	1494	1095	450	504	390	620*	800	525	M20	230	290	345	275	70
N10.12000.37 L-EUF	1441	683	758	1545	1494	1095	450	504	390	620*	800	525	M20	230	290	345	275	70
N10.14000.37 L-EUF	1441	683	758	1545	1494	1095	450	504	390	620*	800	525	M20	230	290	345	275	70
N10.14000.45 L-EUF	1530	683	847	1545	1494	1095	450	504	390	620*	800	525	M20	230	290	345	275	70
N10.16000.45 L-EUF	1530	683	847	1545	1494	1095	450	504	390	620*	800	525	M20	230	290	345	275	70

*: different length on request

PACKAGING

The burner is delivered on a pallet with:

- burner body with mounted combustion head
- boiler fixing accessories
- technical documentation

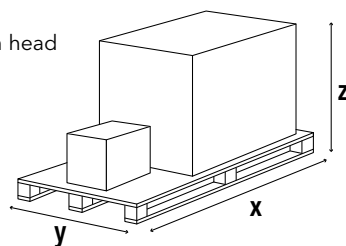

Model	Dimensions (mm)			Gross weight (kg)
	X	Y	Z	
N10... L-EUF	2200	1800	1900	1000

N10 L-E

3600 ... 12000 kW

Two stage progressive/modulating electronic

- **Fuels:** light oil, viscosity 6 mm²/s at 20°C, Hi = 11,86 kWh/kg
- **Emission class:** Low NO_x class 2 (≤185 mg/kWh) according to EN267
- **Protection level:** IP 41 (IP 54 as option)

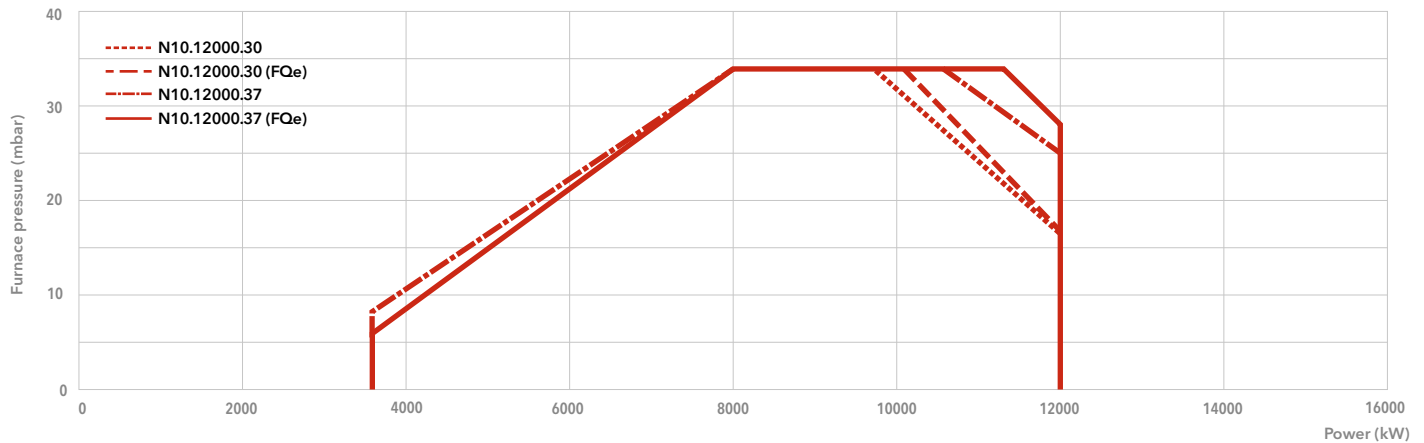
**TECHNICAL DATA**

FQe = external frequency converter

	N10.12000.30 L-E	N10.12000.37 L-E
Operating range	3600 - 12000 kW	3600 - 12000 kW
Control box / flame detector	Etamatic OEM / FFS 08	Etamatic OEM / FFS 08
Fan motor	50/60 Hz - 30 kW	50/60 Hz - 37 kW
Pump	2 200 l/h - 4 kW	2 200 l/h - 4 kW
Acoustic level	< 97 dB(A)	< 97 dB(A)
Complete burner code	on request	on request

DIMENSIONS (mm)

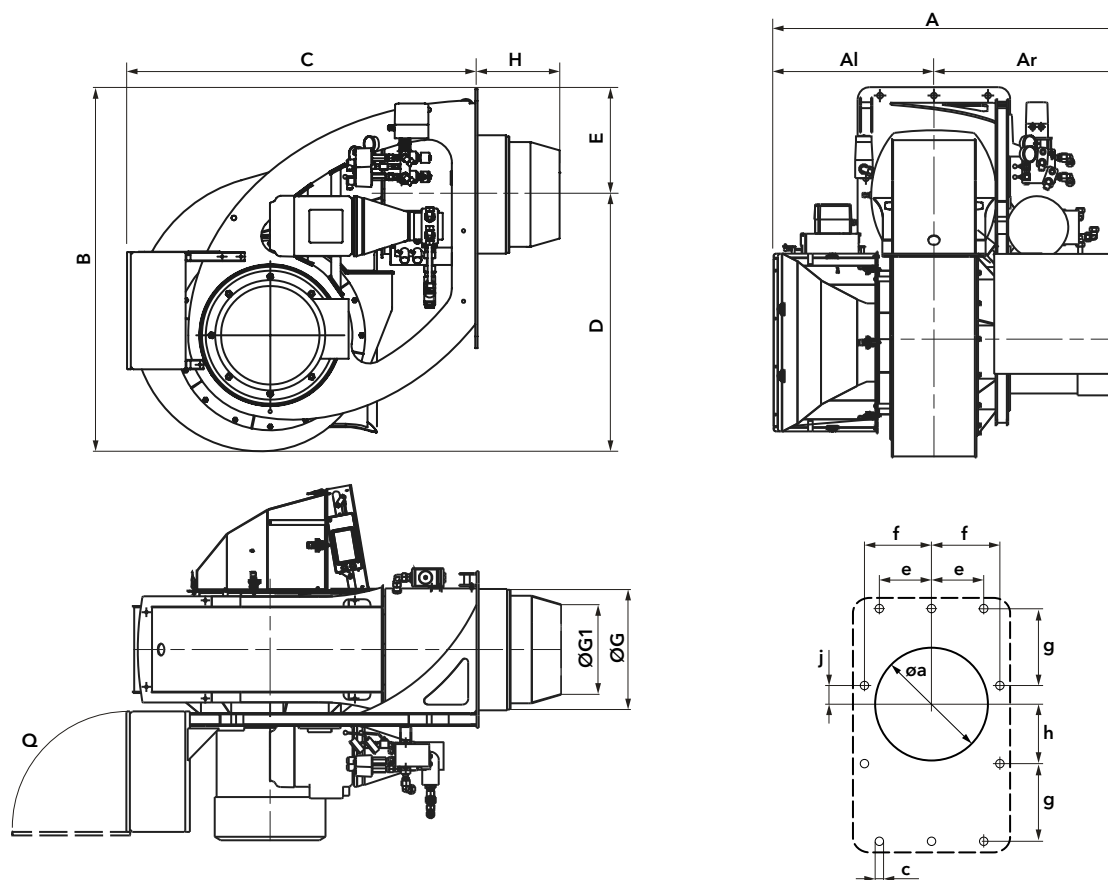

Model	A	Al	Ar	B	C	D	E	ØG	ØG1	H	Q	Øa	c	e	f	g	h	j
N10.12000.30 L-E	1480	685	795	1545	1494	446	450	504	369	350*	800	525	M20	230	290	345	275	70
N10.12000.37 L-E	1480	685	795	1545	1494	446	450	504	369	350*	800	525	M20	230	290	345	275	70

*: different length on request

PACKAGING

The burner is delivered on a pallet with:

- burner body with mounted combustion head
- boiler fixing accessories
- technical documentation

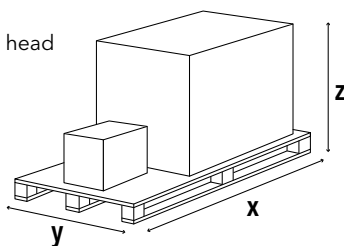

Model	Dimensions (mm)			Gross weight (kg)
	X	Y	Z	
N10... L-E	2200	1800	1900	1000

HO-TRON

MONOBLOCK BURNERS FROM 68 TO 17000 kW HEAVY OIL



HEAVY OIL BURNERS UP TO 17 MW

ELCO offers a wide range of heavy oil burners designed for traditional applications and industrial process applications.

The HO-TRON range offers several models available in different configurations with a power output covering a range from 68 kW to 17 MW.

All models are suitable to work with heavy oil up to 50°E at 50°C.

EASY MAINTENANCE SOLUTIONS

All models feature easy access to the combustion components in order to simplify the maintenance operations.

The maintenance activities are simplified also thanks to the sliding bar system, which allows easy access to the internal components, available on all models up to HO-TRON 6.

BURNER VERSIONS TO SUIT ANY NEED

In order to optimize the performance and the ease of use, the HO-TRON burners are available in the following versions:

- one stage, for HO-TRON 0 and HO-TRON 1, models up to 340 kW;
- two stages, up to the model HO-TRON 4;
- two stage progressive mechanical operation (up to 17 MW).

FLEXIBILITY AND CUSTOMIZATION

All HO-TRON burners are fitted with heavy oil electric heating system on board and integrated electrical panel complete with pre-heater management system. Ring system components for oil preparation can be designed and supply on request.

For a large extent of applications customized solutions can be offered in order to meet plants requirements.

MAIN TECHNICAL FEATURES

- One stage, two stages and two stage progressive/modulating mechanical forced draught burners
- Electronic version available on request
- Fuel: heavy oil, viscosity 50°E at 50°C, Hi = 10,97 kWh/kg
- Two combustion head lengths available
- Pump mounted on the body up to model HO-TRON 6.8500 and separated motor-pump starting from model HO-TRON 6.10500
- Electrical heavy oil heater on board (oil supply to the burner at 80°C and 3 bar)
- Additional heaters on the pipes and the valves, into the pump and the nozzle holder
- Closing of the air flap on burner shut-down
- Complete control panel mounted on the burner with electrical equipment
- Products are in compliance with EN267 European standards and with the following directives:
 - 2014/35/UE Low Voltage Directive
 - 2014/30/UE EMC Directive
 - 2006/42/EC Machinery Directive
 - 2011/65/EU RoHS2 Directive

PRODUCT LIST

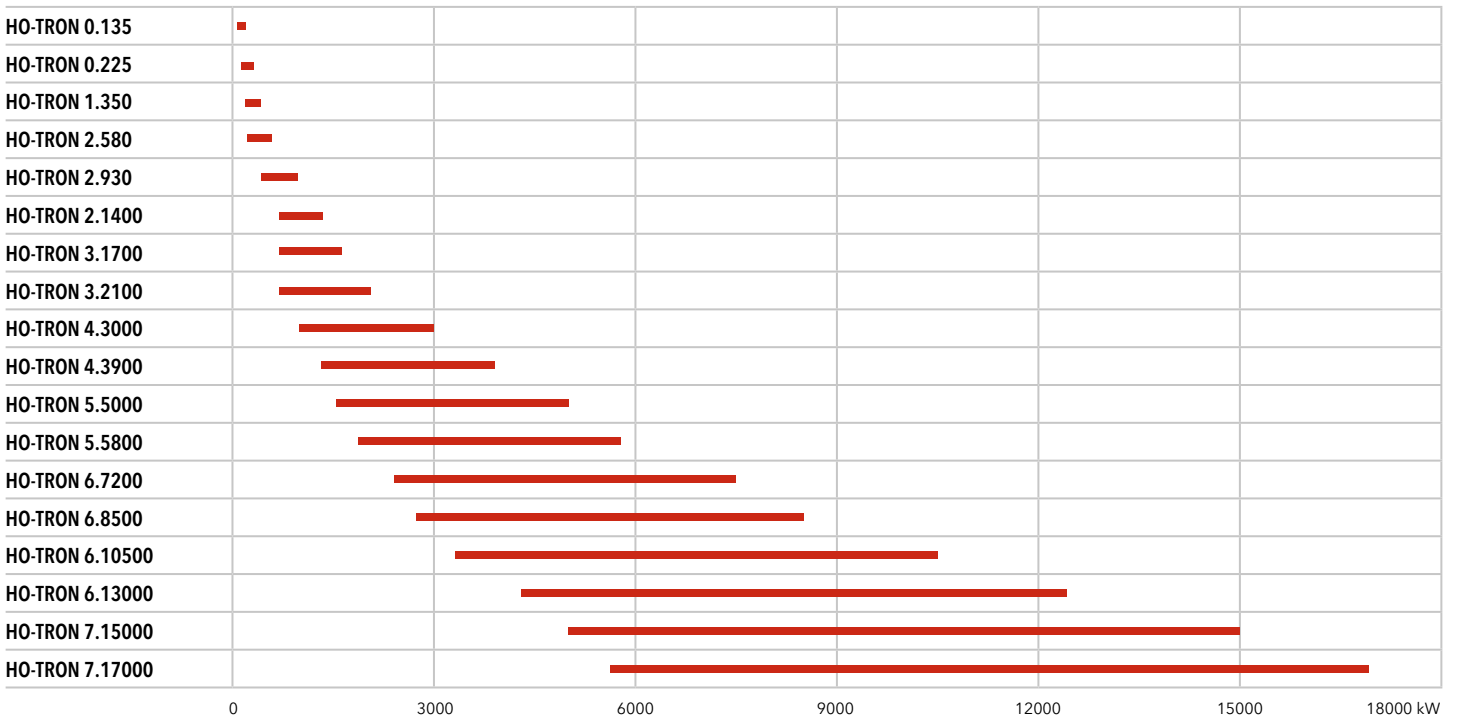

HO-TRON 0

68 ... 227 kW

One stage

- **Fuel:** heavy oil, viscosity 50°E at 50°C, Hi = 10,5...11,5 kWh/kg
- **Protection level:** IP 42 (IP54 on request)

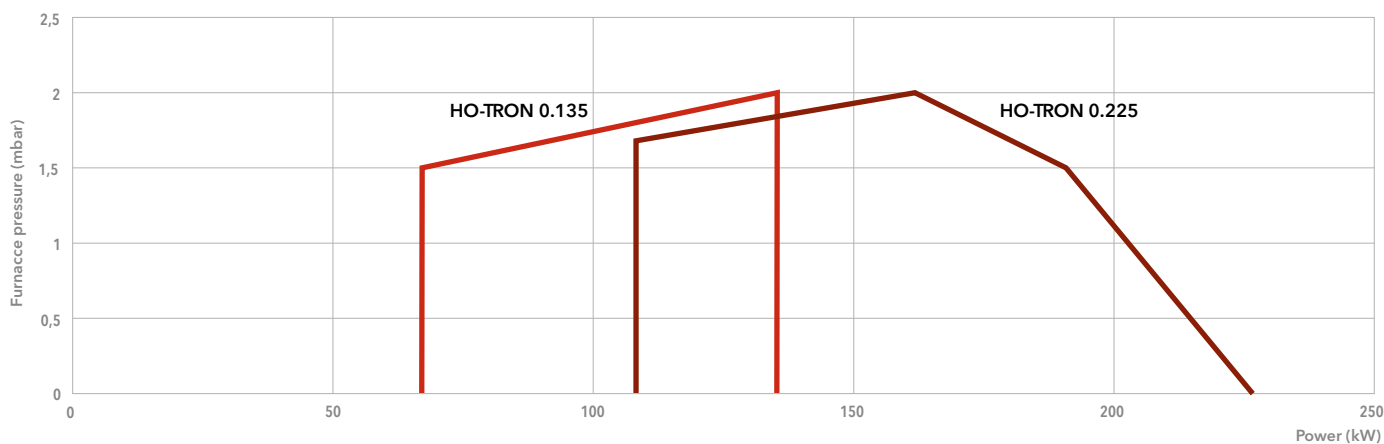
**TECHNICAL DATA**

	HO-TRON 0.135		HO-TRON 0.225	
Operating range	68 - 136 kW		108 - 227 kW	
Fuel flow	6 - 12 kg/h		9,5 - 20 kg/h	
Nozzles	according to required power		according to required power	
Control box	LMO 44		LMO 44	
Fan motor	2 800 rpm - 230 V - 50 Hz - 450 W		2 800 rpm - 230 V - 50 Hz - 450 W	
Pump	D67C		D67C	
Resistance on pre-heaters	2 x 650 W		3 x 650 W	
Head length	KN	KL	KN	KL
Complete burner code	3142568	3142569	3142570	3142571

DIMENSIONS (mm)

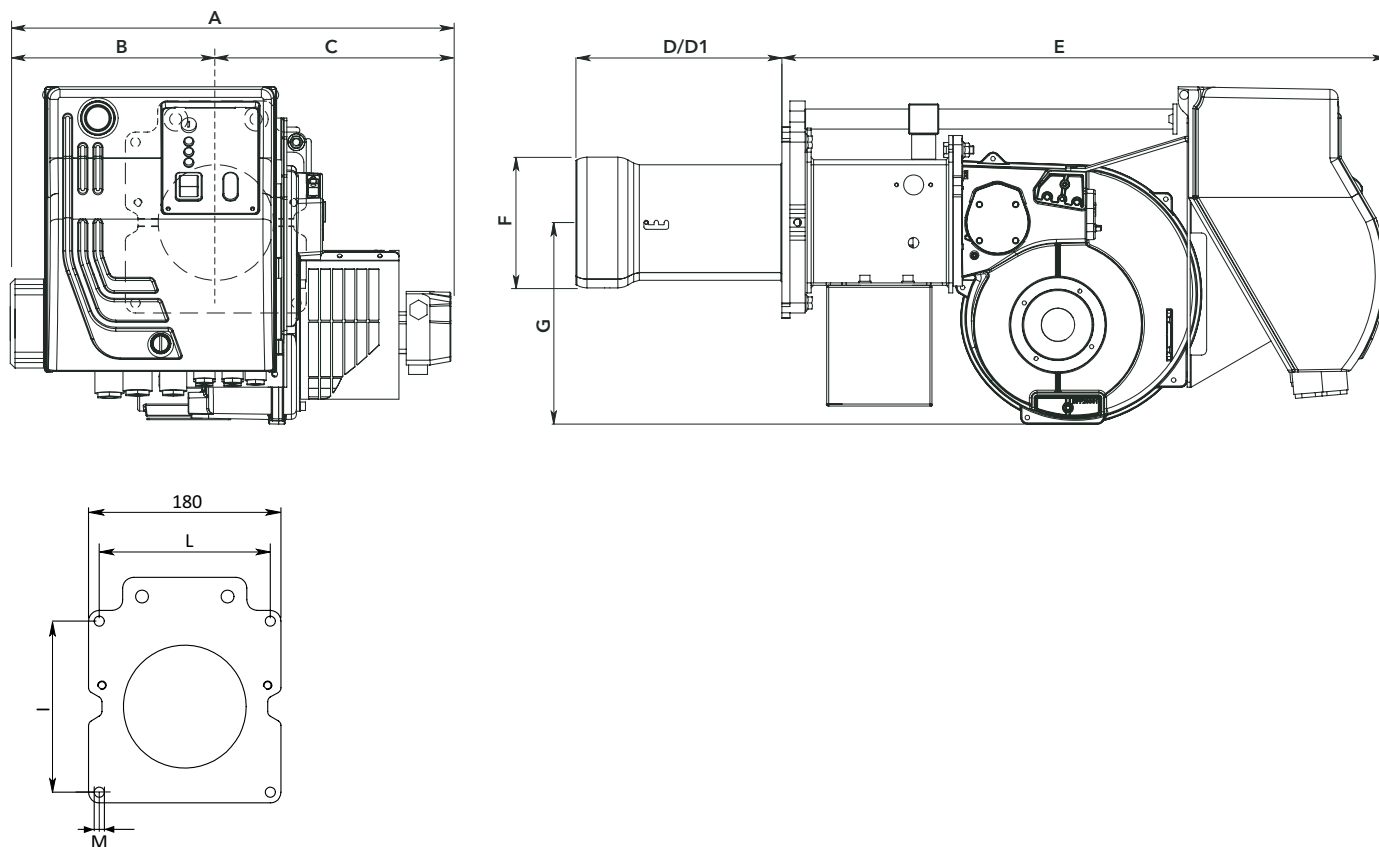

Model	A	B	C	D	D1	E	F	G	I	L	M
HO-TRON 0.135	520	290	230	205	325	535	130	201	160	160	M8
HO-TRON 0.225	520	290	230	205	325	535	130	201	160	160	M8

PACKAGING

The complete burner with combustion head is delivered in a carton box with flexible hoses, boiler fixing accessories and technical documentation.

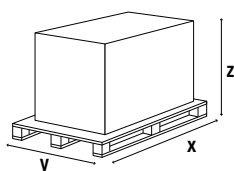

Model	Dimensions (mm)		
	X	Y	Z
HO-TRON 0.135	900	780	700
HO-TRON 0.225	900	780	700

HO-TRON 1 / HO-TRON 1 Z / HO-TRON 2 Z

170 ... 570 kW

One stage / Two stages

- **Fuel:** heavy oil, viscosity 50°E at 50°C, Hi = 10,5...11,5 kWh/kg
- **Protection level:** IP 40

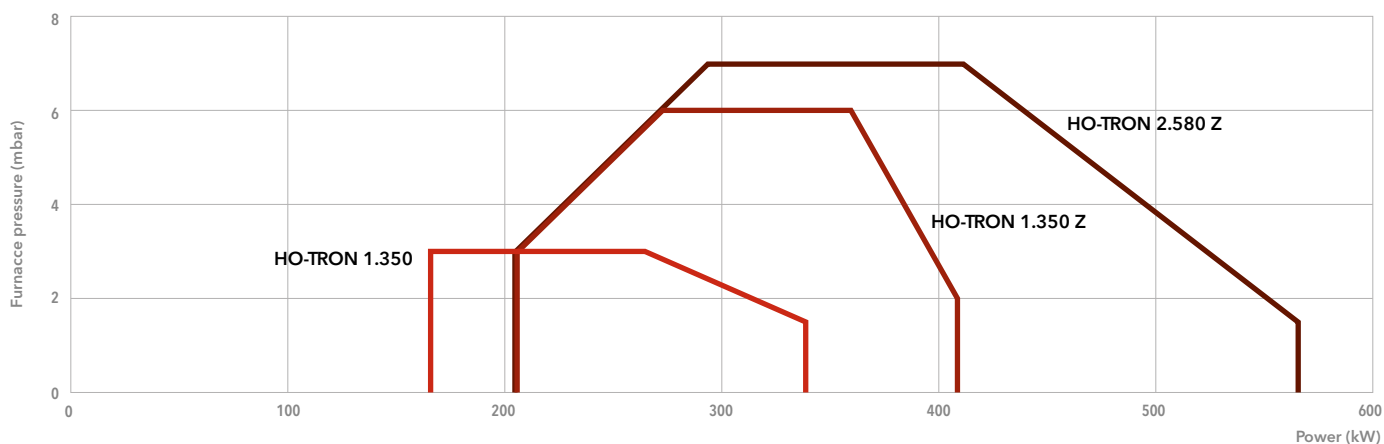
**TECHNICAL DATA**

	HO-TRON 1.350		HO-TRON 1.350 Z		HO-TRON 2.580 Z	
Operating range	170 - 340 kW		205 - 410 kW		205 - 570 kW	
Fuel flow	15 - 30 kg/h		18 - 36 kg/h		18 - 50 kg/h	
Nozzles	according to required power		according to required power		according to required power	
Control box	LMO 44		LMO 44		LMO 44	
Fan motor	2 800 rpm - 230/400 V - 50 Hz - 740 W		2 800 rpm - 230/400 V - 50 Hz - 740 W		2 800 rpm - 230/400 V - 50 Hz - 1100 W	
Pump	E4 NC 1069		E4 NC 1069		E4 NC 1069	
Resistance on pre-heaters	3,9 kW		3,9 kW		3,9 kW	
Head length	KN	KL	KN	KL	KN	KL
Complete burner code	on request	on request	on request	on request	3142671	on request

DIMENSIONS (mm)

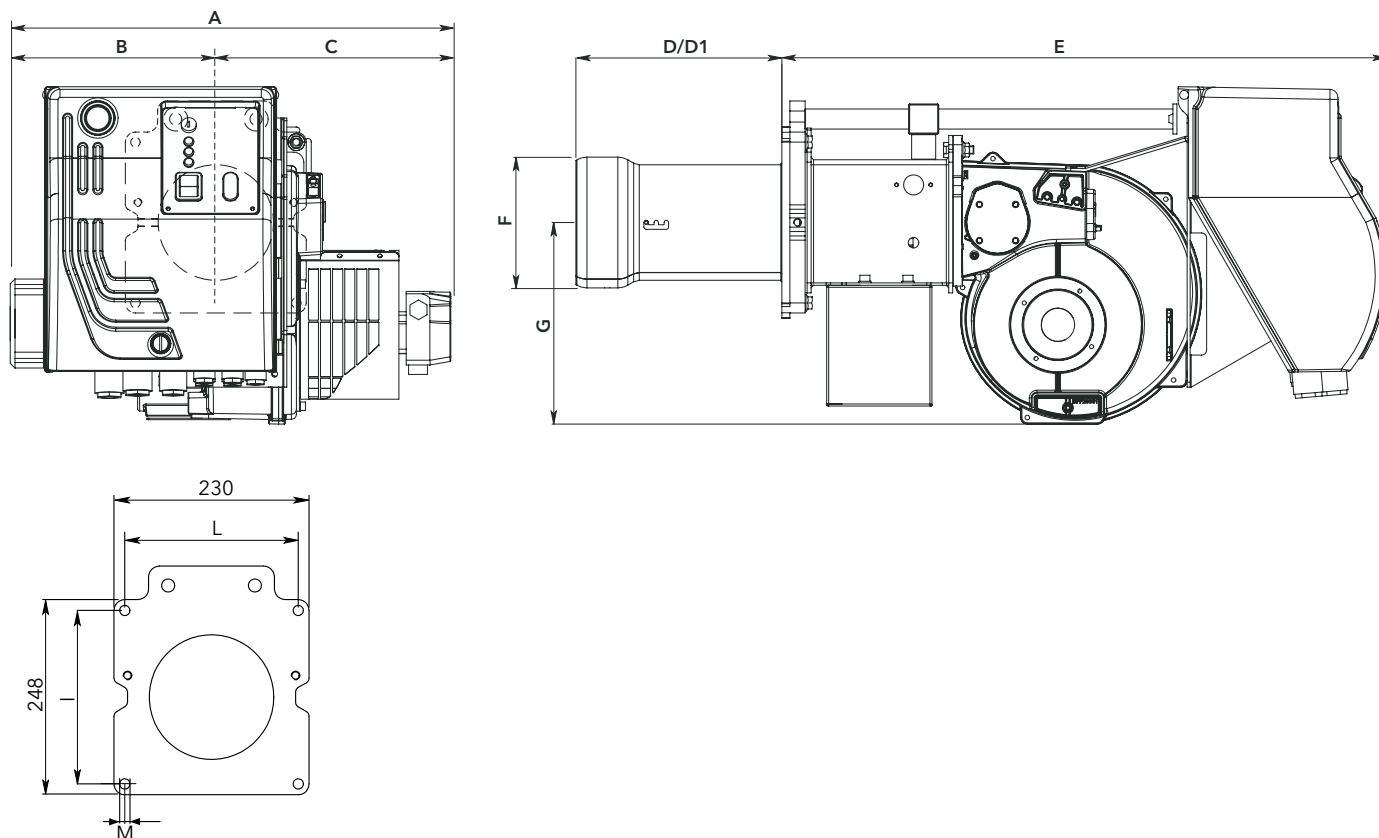

Model	A	B	C	D	D1	E	F	G	I	L	M
HO-TRON 1.350	562	302	260	205	325	653	160	280	185/200	185/200	M10
HO-TRON 1.350 Z	562	302	260	205	325	653	160	280	185/200	185/200	M10
HO-TRON 2.580 Z	562	302	260	205	325	653	160	280	185/200	185/200	M10

PACKAGING

The complete burner with combustion head is delivered in a carton box with flexible hoses, boiler fixing accessories and technical documentation.

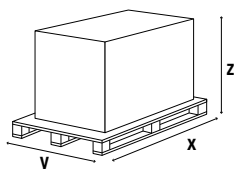

Model	Dimensions (mm)		
	X	Y	Z
HO-TRON 1.350	900	780	700
HO-TRON 1.350 Z	900	780	700
HO-TRON 2.580 Z	900	780	700

HO-TRON 2 Z

465 ... 1395 kW

Two stages

- **Fuel:** heavy oil, viscosity 50°E at 50°C, Hi = 10,5...11,5 kWh/kg
- **Protection level:** IP 42 (IP54 on request)

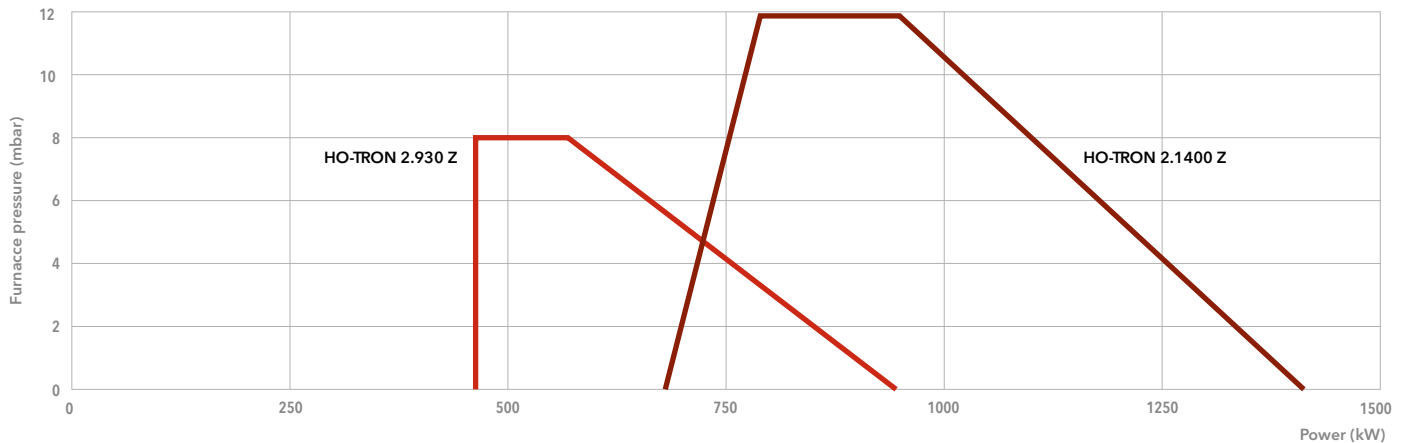
**TECHNICAL DATA**

	HO-TRON 2.930 Z		HO-TRON 2.1400 Z	
Operating range	465 - 930 kW		682 - 1395 kW	
Fuel flow	41 - 82 kg/h		60 - 122 kg/h	
Nozzles	according to required power		according to required power	
Control box	LMO 44		LMO 44	
Fan motor	2800 rpm - 230 V - 50 Hz - 1,5 kW		2800 rpm - 230 V - 50 Hz - 2,2 kW	
Pump	E4 NC 1069		E4 NC 1069	
Resistance on pre-heaters	4,65 kW		7,05 kW	
Head length	KN	KL	KN	KL
Complete burner code	3142672	3142215	3142673	3143193

DIMENSIONS (mm)

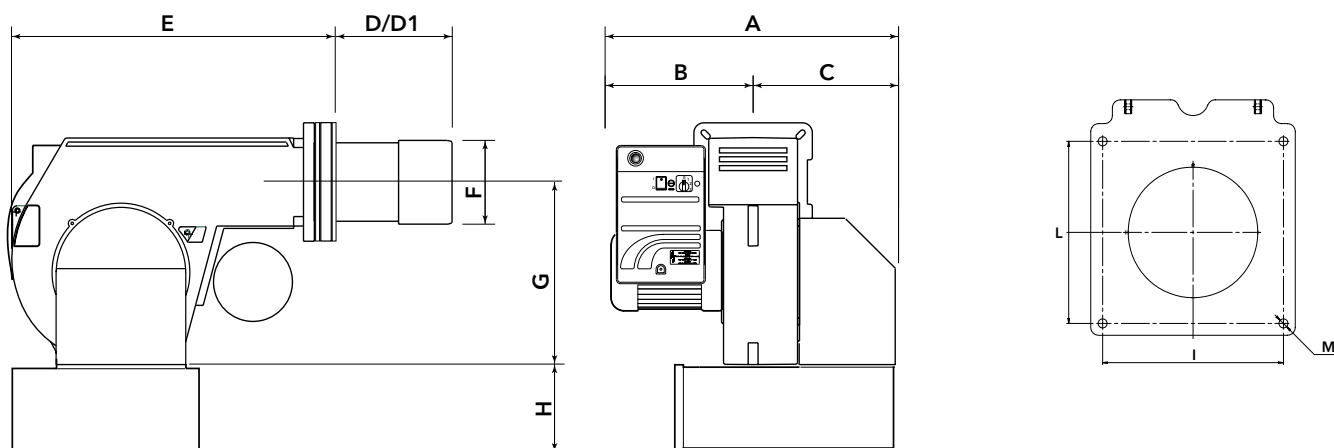

Model	A	B	C	D	D1	E	F	G	H	I	L	M
HO-TRON 2.930 Z	758	388	370	170	310	600	185	390	210*	190	190	M10
HO-TRON 2.1400 Z	758	388	370	170	310	600	185	390	210*	190	190	M10

* optional silencer

PACKAGING

The complete burner with combustion head is delivered in a carton box with flexible hoses, boiler fixing accessories and technical documentation.

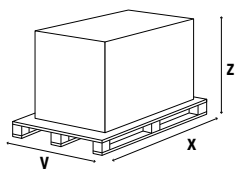

Model	Dimensions (mm)		
	X	Y	Z
HO-TRON 2.930 Z	1100	780	700
HO-TRON 2.1400 Z	1100	780	700

HO-TRON 3 Z

682 ... 2093 kW

Two stages

- **Fuel:** heavy oil, viscosity 50°E at 50°C, Hi = 10,5...11,5 kWh/kg
- **Protection level:** IP 42 (IP54 on request)

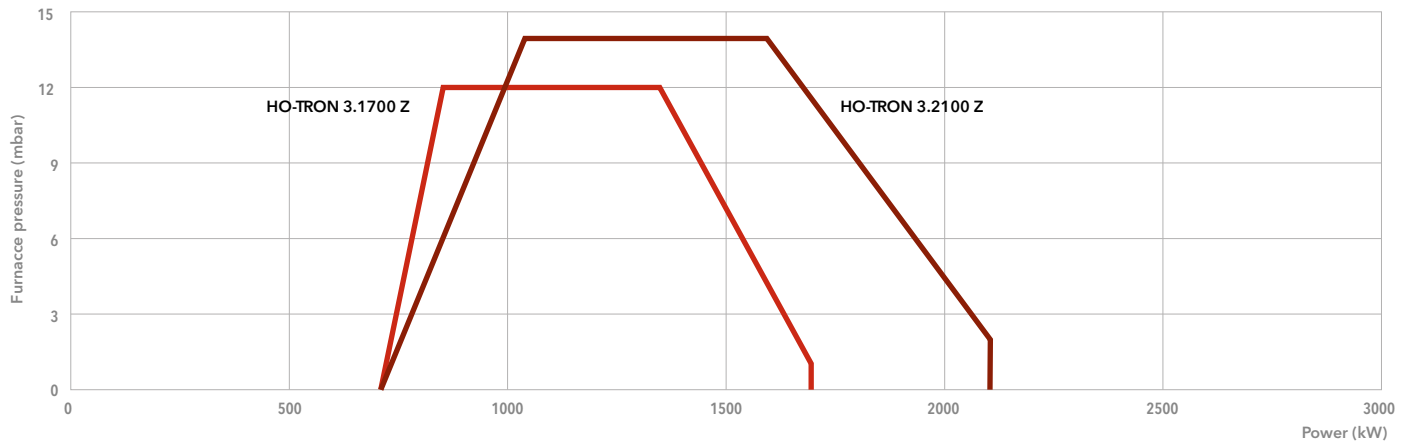
**TECHNICAL DATA**

	HO-TRON 3.1700 Z		HO-TRON 3.2100 Z	
Operating range	682 - 1700 kW		682 - 2093 kW	
Fuel flow	60 - 148 kg/h		60 - 184 kg/h	
Nozzles	according to required power		according to required power	
Control box	LMO 44		LMO 44	
Fan motor	2800 rpm - 230/400 V - 50 Hz - 3 kW		2800 rpm - 230/400 V - 50 Hz - 4 kW	
Pump	E6 NC 1069		E6 NC 1069	
Resistance on pre-heaters	9 kW		10,5 kW	
Head length	KN	KL	KN	KL
Complete burner code	3142675	3143194	3142441	3142677

DIMENSIONS (mm)

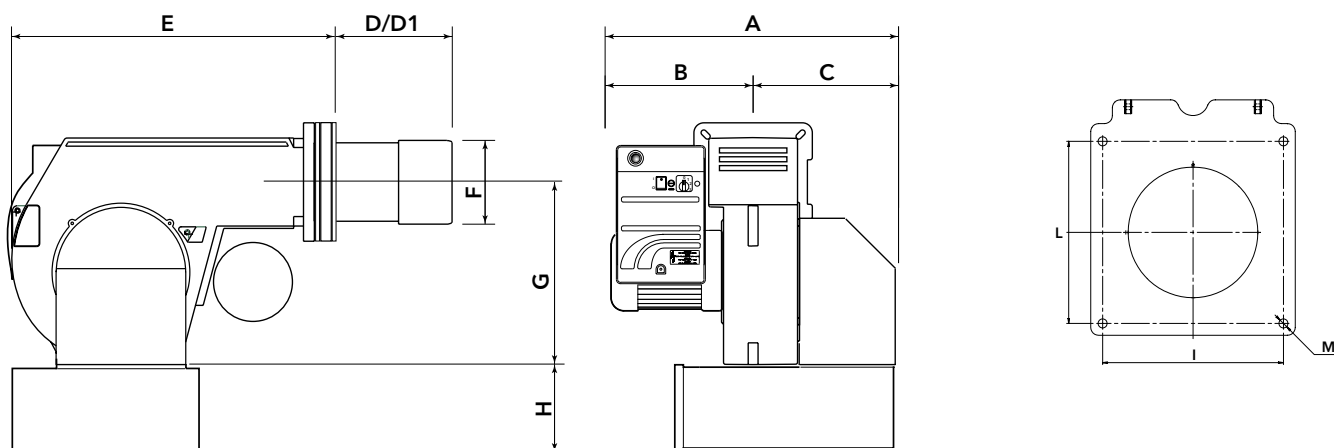

Model	A	B	C	D	D1	E	F	G	H*	I	L	M
HO-TRON 3.1700 Z	920	450	470	280	480	710	250	420	260	315	315	M14
HO-TRON 3.2100 Z	920	450	470	280	480	710	270	420	260	315	315	M14

* optional silencer

PACKAGING

The complete burner with combustion head is delivered in a carton box with flexible hoses, boiler fixing accessories and technical documentation.

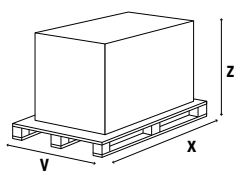

Model	Dimensions (mm)		
	X	Y	Z
HO-TRON 3.1700 Z	1370	1140	950
HO-TRON 3.2100 Z	1370	1140	950

HO-TRON 4 Z/Z3

1000 ... 3900 kW

Two stages

- **Fuel:** heavy oil, viscosity 50°E at 50°C, Hi = 10,5...11,5 kWh/kg
- **Protection level:** IP 42 (IP54 on request)

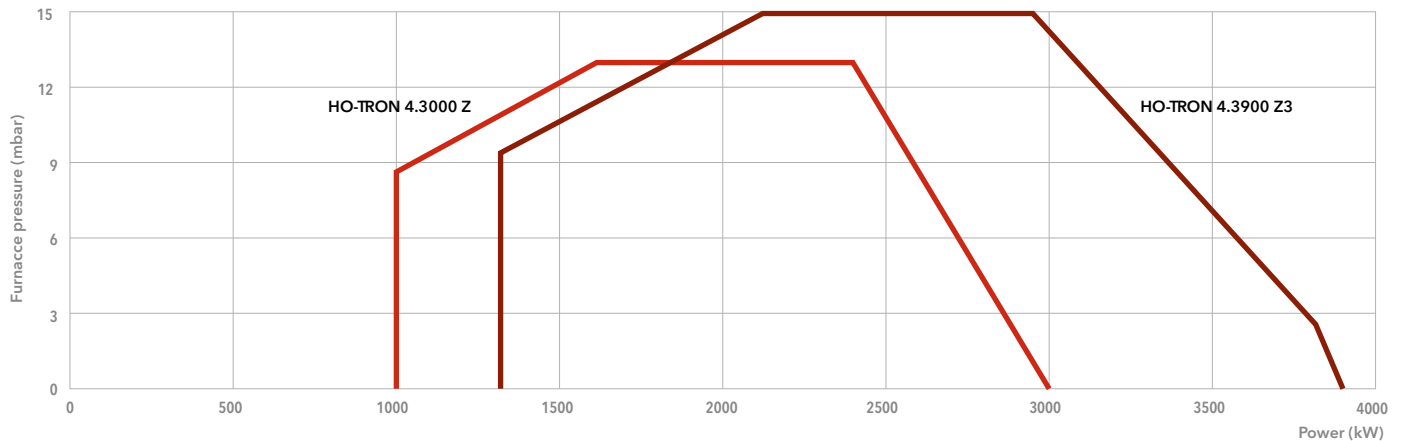
**TECHNICAL DATA**

	HO-TRON 4.3000 Z		HO-TRON 4.3900 Z3	
Operating range	1000 - 3000 kW		1300 - 3900 kW	
Fuel flow	88,5 - 264 kg/h		115 - 343 kg/h	
Nozzles	according to required power		according to required power	
Control box	LMO 44		LMO 44	
Fan motor	2800 rpm - 230/400 V - 50 Hz - 7,5 kW		2800 rpm - 230/400 V - 50 Hz - 9 kW	
Pump	E7 NC 1069		E7 NC 1069	
Resistance on pre-heaters	18 kW		21 kW	
Head length	KN	KL	KN	KL
Complete burner code	3142678	3142679	3142680	3142681

DIMENSIONS (mm)

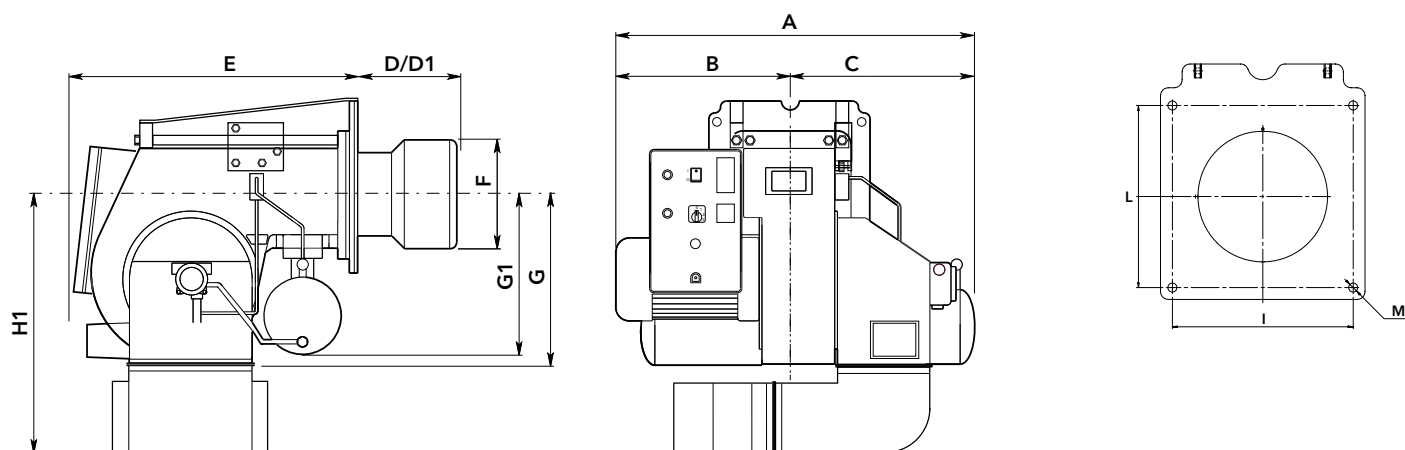

Model	A	B	C	D	D1	E	F	G	G1	H1*	I	L	M
HO-TRON 4.3000 Z	1205	603	602	350	600	925	290	470	430	746	400	400	M16
HO-TRON 4.3900 Z3	1205	603	602	350	600	925	320	470	430	746	400	400	M16

* optional silencer

PACKAGING

The complete burner with combustion head is delivered in a single wooden box with flexible hoses, boiler fixing accessories and technical documentation.

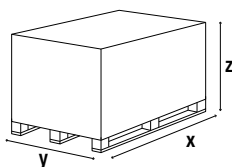

Model	Dimensions (mm)		
	X	Y	Z
HO-TRON 4.3000 Z	1580	1580	1050
HO-TRON 4.3900 Z3	1580	1580	1050

HO-TRON 4 R

1000 ... 3900 kW

Two stage progressive/modulating mechanical

- **Fuel:** heavy oil, viscosity 50°E at 50°C, Hi = 10,5...11,5 kWh/kg
- **Protection level:** IP 42 (IP54 on request)

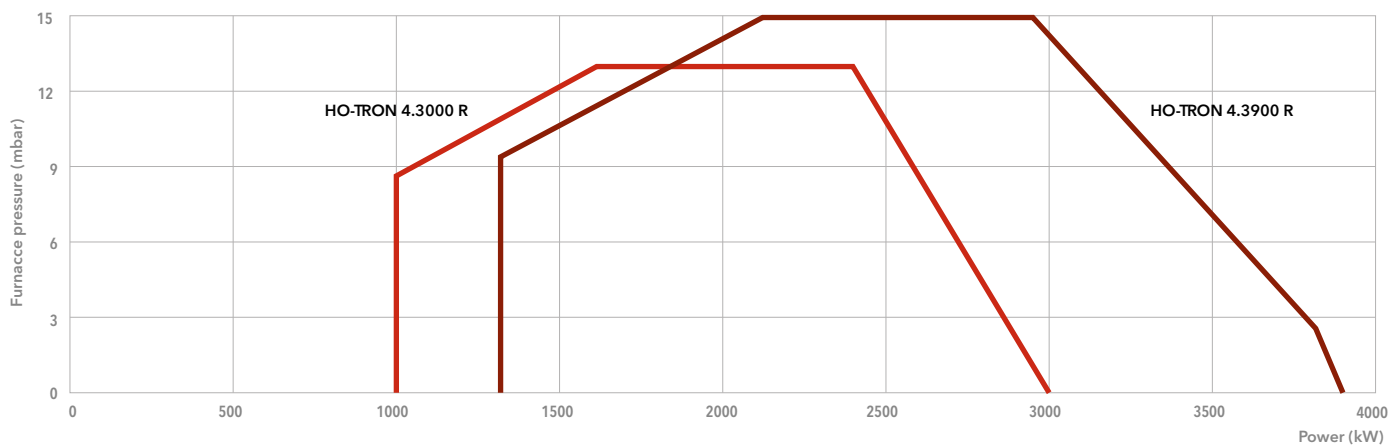
**TECHNICAL DATA**

	HO-TRON 4.3000 R		HO-TRON 4.3900 R	
Operating range	1000 - 3000 kW		1300 - 3900 kW	
Fuel flow	88,5 - 264 kg/h		115 - 343 kg/h	
Nozzles	according to required power		according to required power	
Control box	LAL 1.25		LAL 1.25	
Fan motor	2800 rpm - 230/400 V - 50 Hz - 7,5 kW		2800 rpm - 230/400 V - 50 Hz - 9 kW	
Pump	TA 3C		TA 3C	
Resistance on pre-heaters	18 kW		21 kW	
Head length	KN	KL	KN	KL
Complete burner code	on request	on request	on request	on request

DIMENSIONS (mm)

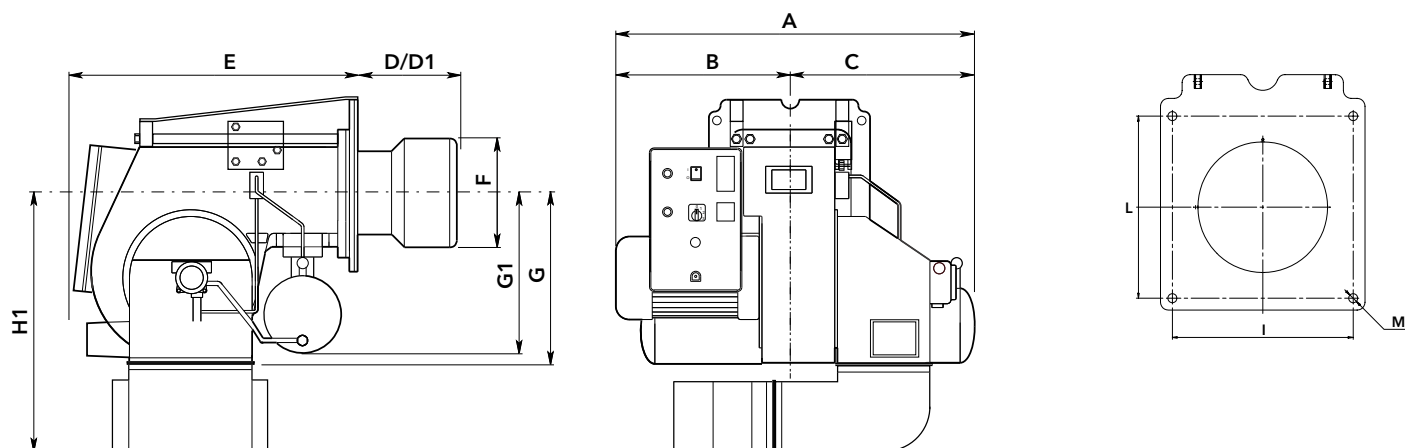

Model	A	B	C	D	D1	E	F	G	G1	H1*	I	L	M
HO-TRON 4.3000 R	1205	603	602	350	600	925	290	470	430	746	400	400	M16
HO-TRON 4.3900 R	1205	603	602	350	600	925	320	470	430	746	400	400	M16

* optional silencer

PACKAGING

The complete burner with combustion head is delivered in a single wooden box with flexible hoses, boiler fixing accessories and technical documentation.

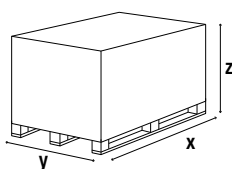

Model	Dimensions (mm)		
	X	Y	Z
HO-TRON 4.3000 R	1580	1580	1050
HO-TRON 4.3900 R	1580	1580	1050

HO-TRON 5 R

1578 ... 5800 kW

Two stage progressive/modulating mechanical

- **Fuel:** heavy oil, viscosity 50°E at 50°C, Hi = 10,5...11,5 kWh/kg
- **Protection level:** IP 42 (IP54 on request)

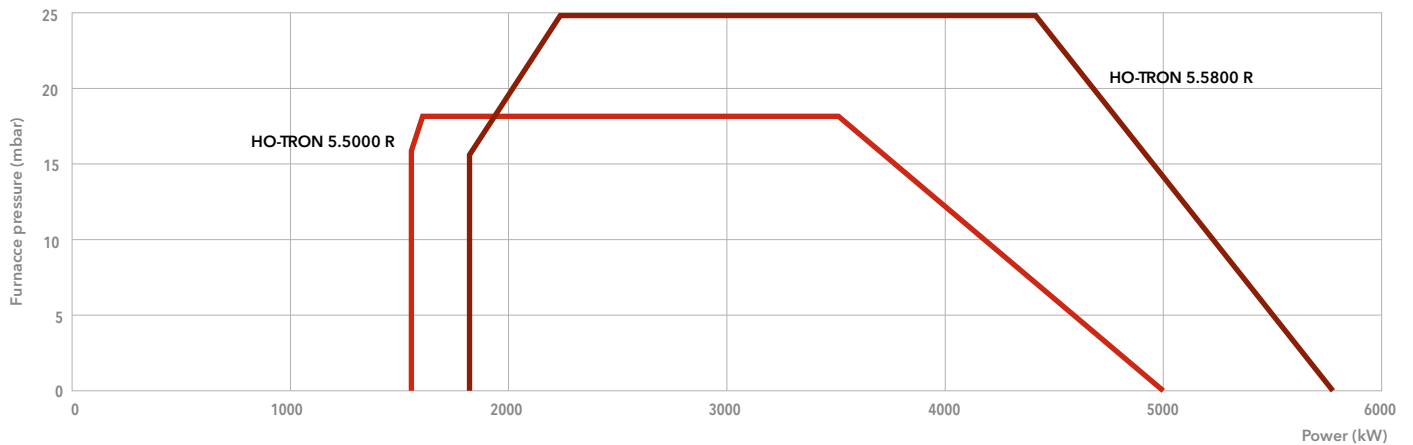
**TECHNICAL DATA**

	HO-TRON 5.5000 R		HO-TRON 5.5800 R	
Operating range	1578 - 5000 kW		1795 - 5800 kW	
Fuel flow	140 - 440 kg/h		159 - 510 kg/h	
Nozzles	according to required power		according to required power	
Control box	LAL 1.25		LAL 1.25	
Fan motor	2800 rpm - 230/400 V - 50 Hz - 11 kW		2800 rpm - 230/400 V - 50 Hz - 15 kW	
Pump	TA 4C		TA 4C	
Resistance on pre-heaters	24 kW		24 kW	
Head length	KN	KL	KN	KL
Complete burner code	3143183	on request	on request	on request

DIMENSIONS (mm)

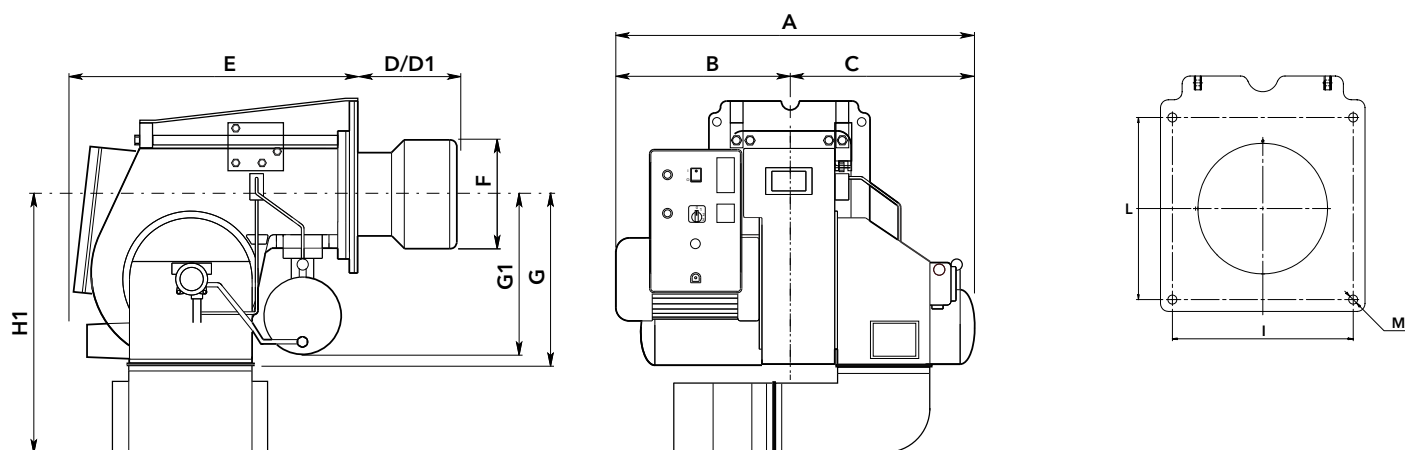

Model	A	B	C	D	D1	E	F	G	G1	H1	I	L	M
HO-TRON 5.5000 R	1300	610	690	370	670	990	320	570	480	965	460	460	M16
HO-TRON 5.5800 R	1300	610	690	370	670	990	320	570	480	965	460	460	M16

* optional silencer

PACKAGING

The complete burner with combustion head is delivered in a single wooden box with flexible hoses, boiler fixing accessories and technical documentation.

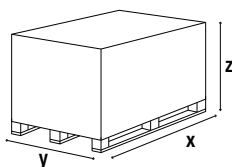

Model	Dimensions (mm)		
	X	Y	Z
HO-TRON 5.5000 R	1580	1580	1050
HO-TRON 5.5800 R	1580	1580	1050

HO-TRON 6 R

2417 ... 12500 kW

Two stage progressive/modulating mechanical

- **Fuel:** heavy oil, viscosity 50°E at 50°C, Hi = 10,5...11,5 kWh/kg
- **Protection level:** IP 42 (IP54 on request)

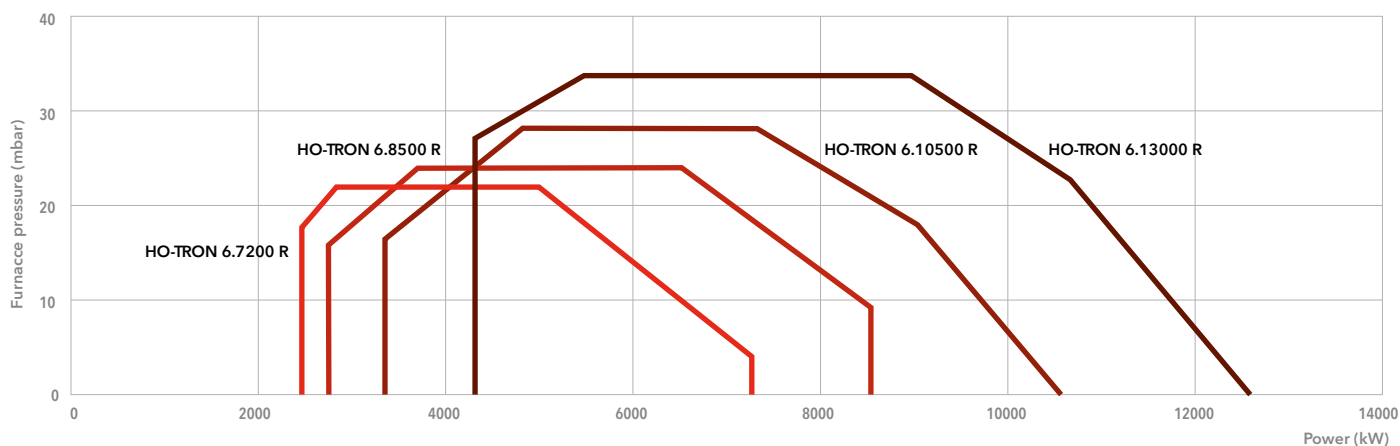
**TECHNICAL DATA**

	HO-TRON 6.7200 R		HO-TRON 6.8500 R		HO-TRON 6.10500 R		HO-TRON 6.13000 R	
Operating range	2417 - 7500 kW		2750 - 8500 kW		3300 - 10500 kW		4367 - 12500 kW	
Fuel flow	214 - 660 kg/h		243 - 748 kg/h		292 - 924 kg/h		386 - 1099 kg/h	
Nozzles	according to required power		according to required power		according to required power		according to required power	
Control box	LAL 2.25		LAL 2.25		LAL 2.25		LAL 2.25	
Fan motor	2800 rpm - 230/400 V 50 Hz - 15 kW		2800 rpm - 230/400 V 50 Hz - 18,5 kW		2800 rpm - 230/400 V 50 Hz - 22 kW		2800 rpm - 230/400 V 50 Hz - 37 kW	
Pump	TA 5C		TA 5C		T5 + TV		T5 + TV	
Resistance on pre-heaters	30 kW		30 kW		44 kW		60 kW	
Head length	KN	KL	KN	KL	KN	KL	KN	KL
Complete burner code	on request	on request	3143166	on request	on request	on request	3142911	on request

DIMENSIONS (mm)

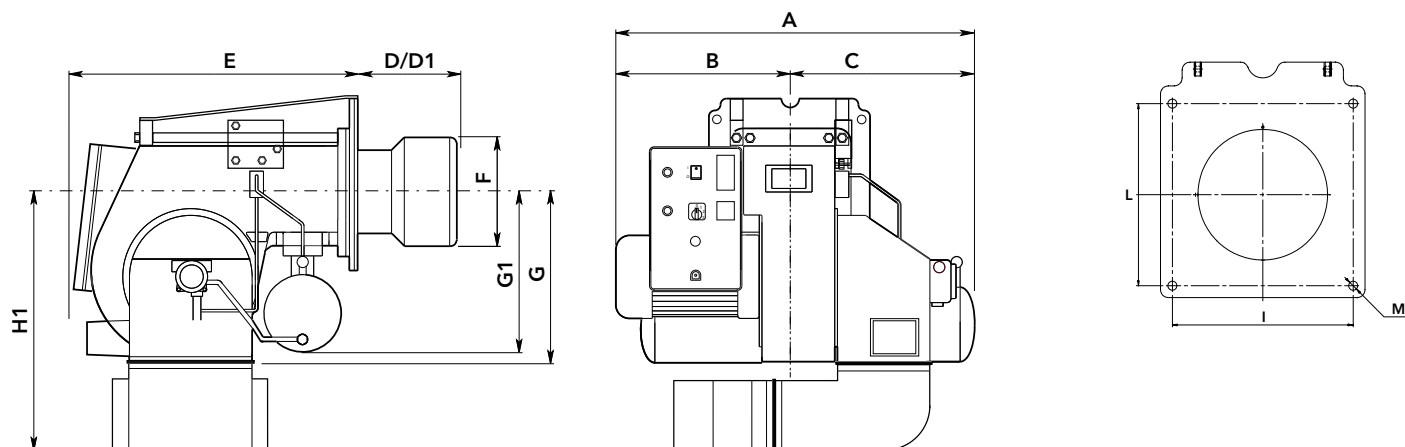

Model	A	B	C	D	E	F	G	G1	H1*	I	L	M
HO-TRON 6.7200 R	1390	660	730	525	1240	385	775	520	1270	460	460	M20
HO-TRON 6.8500 R	1480	660	820	535	1240	430	775	520	1270	460	460	M20
HO-TRON 6.10500 R	1505	685	820	535	1240	460	775	520	1270	460	460	M20
HO-TRON 6.13000 R	1750	800	950	535	1410	460	775	900	1270	460	460	M20

* optional silencer

PACKAGING

The complete burner with combustion head is delivered in a single wooden box with flexible hoses, boiler fixing accessories and technical documentation.

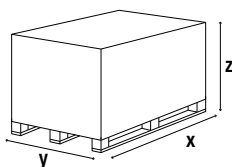

Model	Dimensions (mm)		
	X	Y	Z
HO-TRON 6.7200 R	2400	1800	1600
HO-TRON 6.8500 R	2400	1800	1600
HO-TRON 6.10500 R	2400	1800	1600
HO-TRON 6.13000 R	2400	1800	1600

HO-TRON**HEAVY OIL****HO-TRON 7 R**

5000 ... 17000 kW

Two stage progressive/modulating mechanical

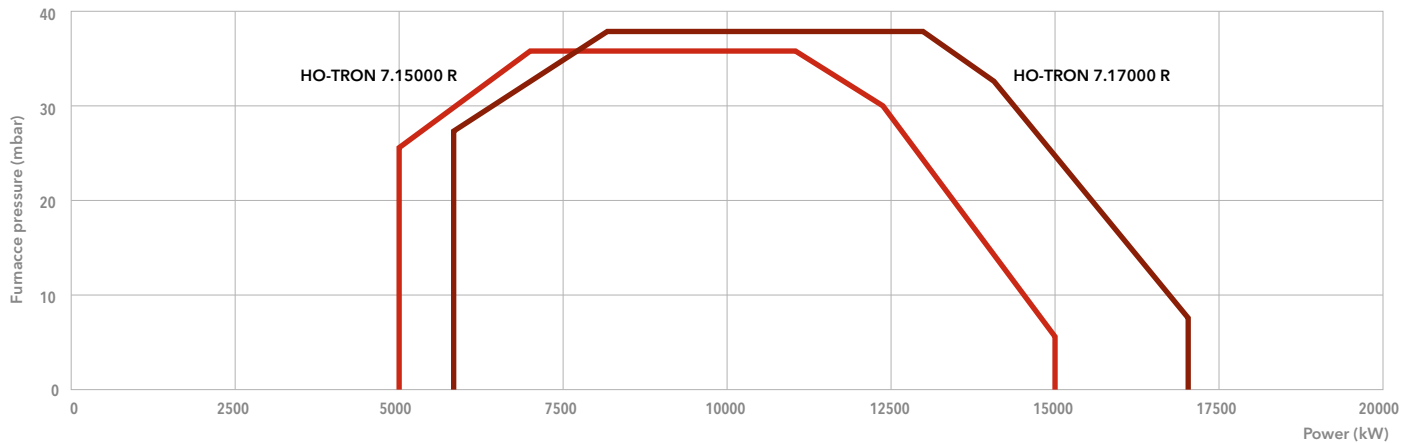

- **Fuel:** heavy oil, viscosity 50°E at 50°C, Hi = 10,5...11,5 kWh/kg
- **Protection level:** IP 42 (IP54 on request)

TECHNICAL DATA

	HO-TRON 7.15000 R		HO-TRON 7.17000 R	
Operating range	5000 - 15000 kW		5700 - 17000 kW	
Fuel flow	440 - 1319 kg/h		500 - 1495 kg/h	
Nozzles	according to required power		according to required power	
Control box	LAL 1.25		LAL 1.25	
Fan motor	2800 rpm - 230/400 V - 50 Hz - 45 kW		2800 rpm - 230/400 V - 50 Hz - 55 kW	
Pump	T5 + TV		T5 + TV	
Resistance on pre-heaters	75 kW		75 kW	
Head length	KN	KL	KN	KL
Complete burner code	on request	on request	on request	on request

DIMENSIONS (mm)

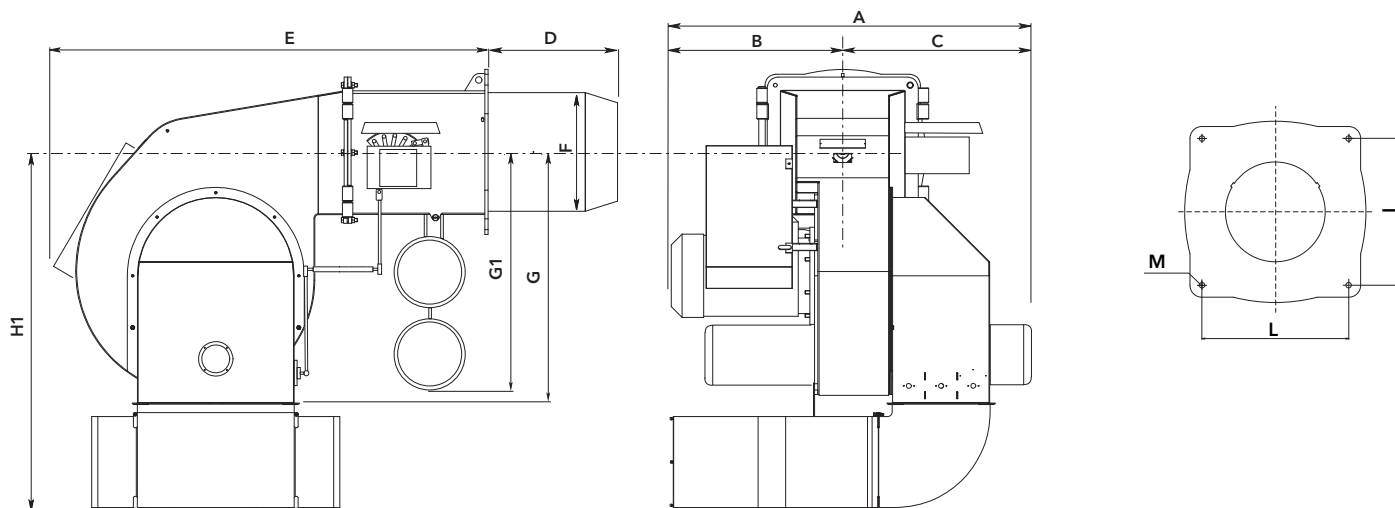

Model	A	B	C	D	E	F	G	G1	H1*	I	L	M
HO-TRON 7.15000 R	1700	800	900	590	1910	550	1320	1220	1670	620	620	M20
HO-TRON 7.17000 R	1770	870	900	590	1910	550	1320	1220	1670	620	620	M20

* optional silencer

PACKAGING

The complete burner with combustion head is delivered in a single wooden box with flexible hoses, boiler fixing accessories and technical documentation.

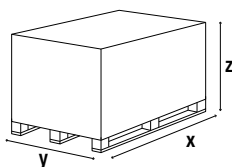

Model	Dimensions (mm)		
	X	Y	Z
HO-TRON 7.15000 R	2800	2100	2000
HO-TRON 7.17000 R	2800	2100	2000

GHO-TRON

**MONOBLOCK BURNERS
FROM 414 TO 17000 kW
DUAL FUEL (GAS/HEAVY OIL)**



DUAL FUEL BURNERS WORKING WITH GAS AND HEAVY OIL

GHO-TRON burners are suitable to work with natural gas or heavy oil up to 50°E at 50°C.

The range includes models ranging from a minimum capacity of 414 kW to a maximum power output of 17 MW.

Configured and special version on request for selected type of applications and fuel characteristics.

SPECIAL FEATURES FOR HEAVY OIL COMBUSTION

All the models of the range are fitted with special components for heavy oil combustion.

Models starting from GHO-TRON 3 are equipped with digital thermoregulator integrated on the front panel to grant temperature stability of the fuel.

All the burners of the series have an heavy oil electric heating system on board and, starting from GHO-TRON 6, gas pilot included with separate supply line.

BURNER VERSIONS TO SUIT ANY NEED

The GHO-TRON dual fuel range is available in two different configurations:

- two stage version with electric servomotor and integrated system for the regulation of air and fuel for the model GHO-TRON 3
- two stage progressive version with electrical servomotor and double adjustable mechanical cam that allows air and fuel fine tuning (for models up to 17 MW).

EASY MAINTENANCE SOLUTIONS

GHO-TRON burners feature an adjustable combustion head for easy regulation and matching with different combustion chambers.

All burners are characterized by easy access to the combustion components in order to simplify the maintenance operations.

MAIN TECHNICAL FEATURES

- Two stages and two stage progressive/modulating mechanical forced draught burners
- Electronic version available on request
- Fuels:
 - natural gas, Hi = 6,99 ... 11,39 kWh/Nm³
 - heavy oil, viscosity 50°E at 50°C, net calorific value 10,97 kWh/kg
- Two combustion head lengths available
- Gun type architecture:
 - separated forced draught fan;
 - optimal accessibility;
 - easy maintenance;
 - secured burner head adjustments;
 - closing of the air flap on burner shut-down
- Separated motor-pump on board
- Electrical heavy oil heater (oil supply to the burner at 80°C and 3 bar)
- Additional heating on the pipes and the valves, into the pump and the nozzle holder
- Closing of the air flap on burner shut-down
- Complete electrical equipment in a switch cabinet mounted on the burner with control panel
- Products are in compliance with EN267 and EN676 European standards and with the following directives:
 - 2014/35/UE Low Voltage Directive
 - 2014/30/UE EMC Directive
 - 2016/426/UE Gas Appliances Regulation
 - 2006/42/EC Machinery Directive
 - 2011/65/EU RoHS2 Directive

PRODUCT LIST

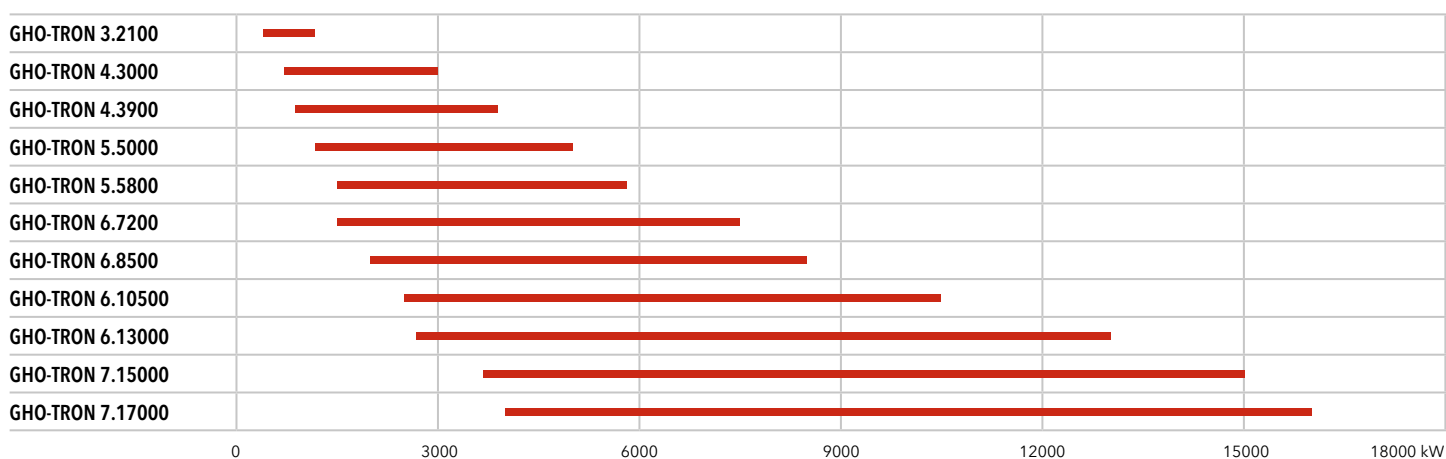

GHO-TRON 3 Z

414 ... 2150 kW

Two stages

- **Fuels:** natural gas, Hi = 6,99 ... 11,39 kWh/Nm³;
heavy oil, viscosity 50°E at 50°C, Hi = 10,5...11,5 kWh/kg
- **Emission class:** Low NO_x class 2 (≤120 mg/kWh) according to EN676 in gas
- **Protection level:** IP 42 (IP54 on request)

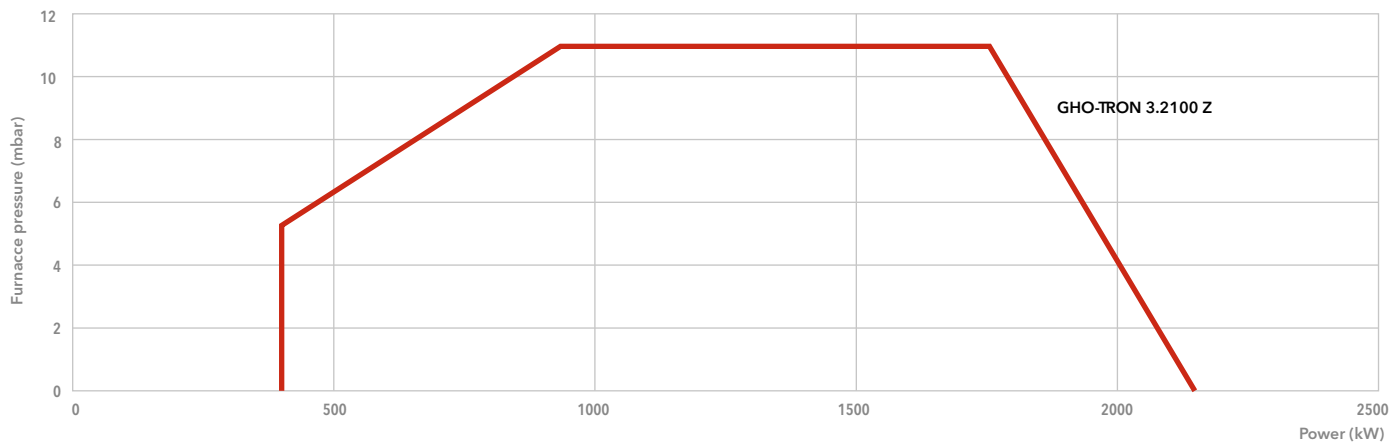
**TECHNICAL DATA**

GHO-TRON 3.2100 Z	
Operating range	414 - 2150 kW
Fuel flow	36 - 189 kg/h
Nozzles	according to required power
Control box	LGB 22
Fan motor	2800 rpm - 230/400 V - 50 Hz - 4 kW
Pump	E7 NC
Resistance on pre-heaters	10,5 kW
Head length	KN KL
Complete burner code	on request on request

i Dimensions of gas trains and gas filters: see page 314

DIMENSIONS (mm)

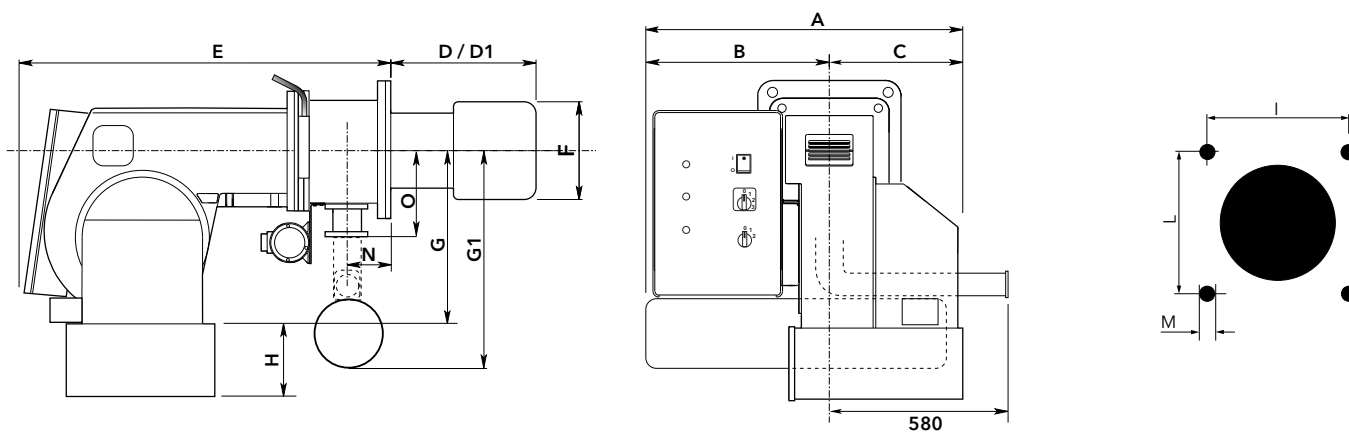

Model	A	B	C	D	D1	E	F	G	G1	H	N	O	I	L	M
GHO-TRON 3.2100 Z	848	530	318	295	455	1150	270	395	600	283	125	250	315	315	M16

* optional silencer

PACKAGING

The complete burner with combustion head is delivered in a single carton box with flexible hoses and operating manual including electrical terminal diagram and spare parts list.

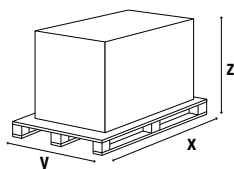

Model	Dimensions (mm)		
	X	Y	Z
GHO-TRON 3.2100 Z	1370	1140	950

GHO-TRON 4 R

650 ... 3900 kW

Two stage progressive/modulating mechanical

- **Fuels:** natural gas, Hi = 6,99 ... 11,39 kWh/Nm³;
heavy oil, viscosity 50°E at 50°C, Hi = 10,5...11,5 kWh/kg
- **Emission class:** Low NOx class 2 (≤ 120 mg/kWh) according to EN676 in gas
- **Protection level:** IP 42 (IP54 on request)

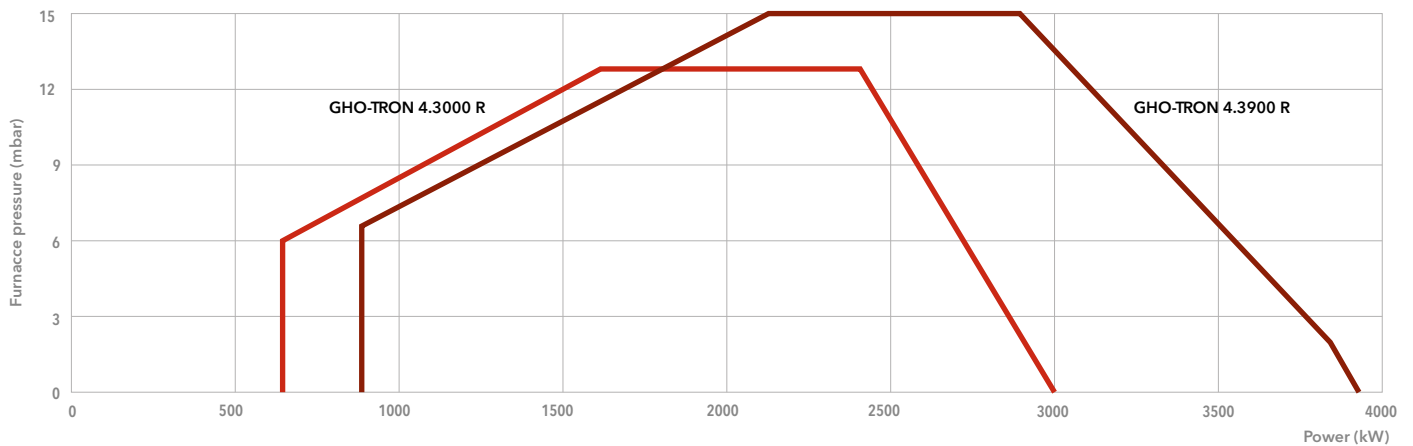
**TECHNICAL DATA**

	GHO-TRON 4.3000 R		GHO-TRON 4.3900 R	
Operating range	650 - 3000 kW		875 - 3900 kW	
Fuel flow	57 - 264 kg/h		77 - 343 kg/h	
Nozzles	according to required power		according to required power	
Control box	LFL 1.333		LFL 1.333	
Fan motor	2800 rpm - 230/400 V - 50 Hz - 7,5 kW		2800 rpm - 230/400 V - 50 Hz - 9 kW	
Pump	TA 3C		TA 3C	
Resistance on pre-heaters	18 kW		21 kW	
Head length	KN	KL	KN	KL
Complete burner code	on request	on request	on request	on request

i Dimensions of gas trains and gas filters: see page 314

DIMENSIONS (mm)

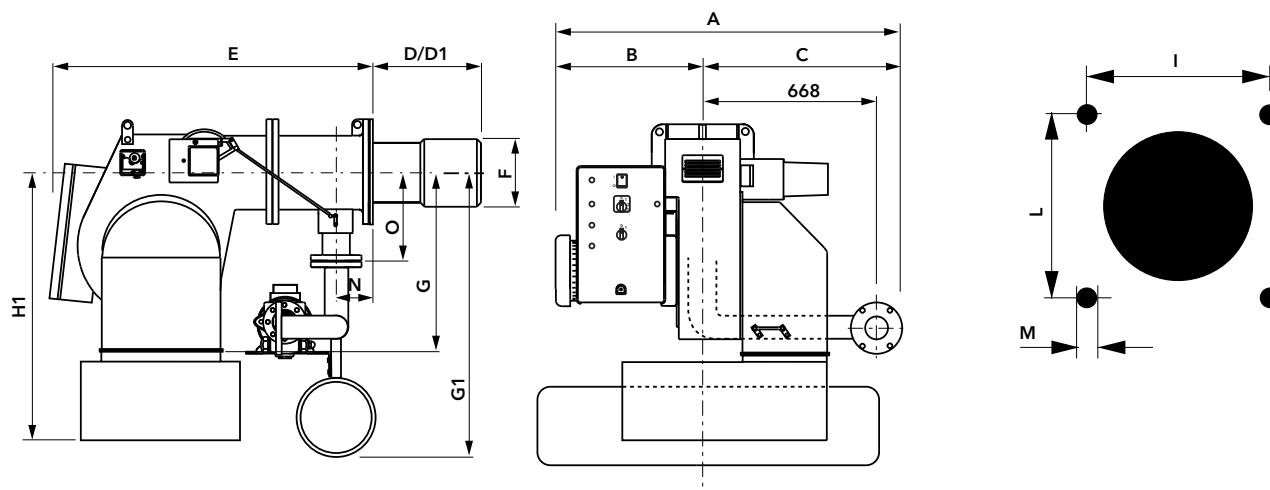

Model	A	B	C	D	D1	E	F	G	G1	H1*	N	O	I	L	M
GHO-TRON 4.3000 R	1288	610	678	330	530	1130	290	471	750	746	195	250	315	315	M16
GHO-TRON 4.3900 R	1288	610	678	345	545	1130	320	471	750	746	195	250	315	315	M16

* optional silencer

PACKAGING

The complete burner with combustion head is delivered in a single wooden box with gas train and filter, flexible hoses, boiler fixing accessories and technical documentation.

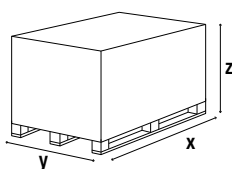

Model	Dimensions (mm)		
	X	Y	Z
GHO-TRON 4.3000 R	1580	1580	1050
GHO-TRON 4.3900 R	1580	1580	1050

GHO-TRON 5 R

1200 ... 5800 kW

Two stage progressive/modulating mechanical

- **Fuels:** natural gas, Hi = 6,99 ... 11,39 kWh/Nm³;
heavy oil, viscosity 50°E at 50°C, Hi = 10,5...11,5 kWh/kg
- **Emission class:** Low NOx class 2 (≤ 120 mg/kWh) according to EN676 in gas
- **Protection level:** IP 42 (IP54 on request)

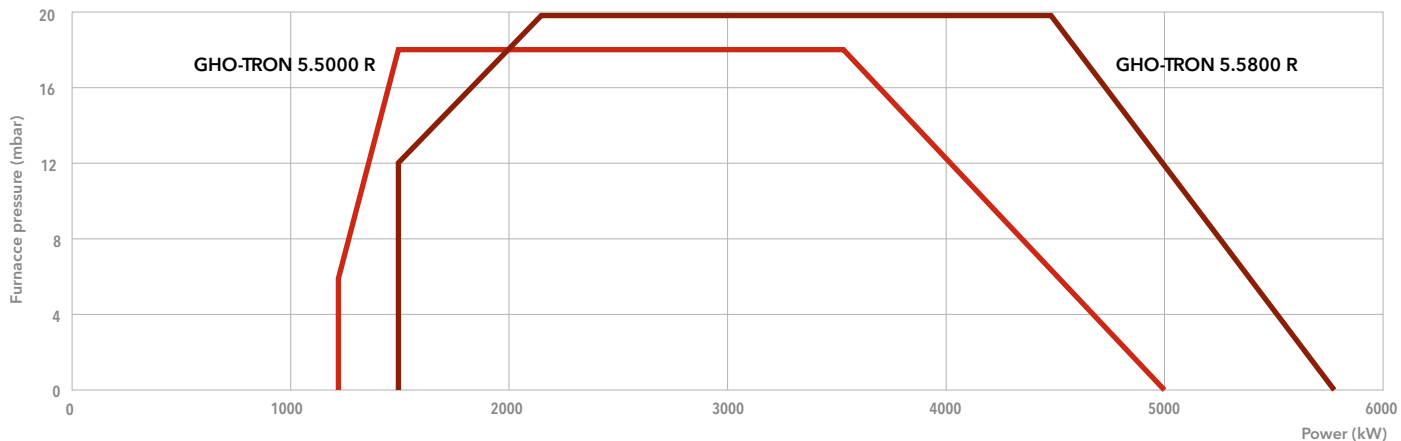
**TECHNICAL DATA**

	GHO-TRON 5.5000 R		GHO-TRON 5.5800 R	
Operating range	1200 - 5000 kW		1500 - 5800 kW	
Fuel flow	106 - 440 kg/h		132 - 510 kg/h	
Nozzles	according to required power		according to required power	
Control box	LFL 1.333		LFL 1.333	
Fan motor	2800 rpm - 230/400 V - 50 Hz - 11 kW		2800 rpm - 230/400 V - 50 Hz - 15 kW	
Pump	TA 4C		TA 4C	
Resistance on pre-heaters	24 kW		24 kW	
Head length	KN	KL	KN	KL
Complete burner code	on request	on request	on request	on request

i Dimensions of gas trains and gas filters: see page 314

DIMENSIONS (mm)

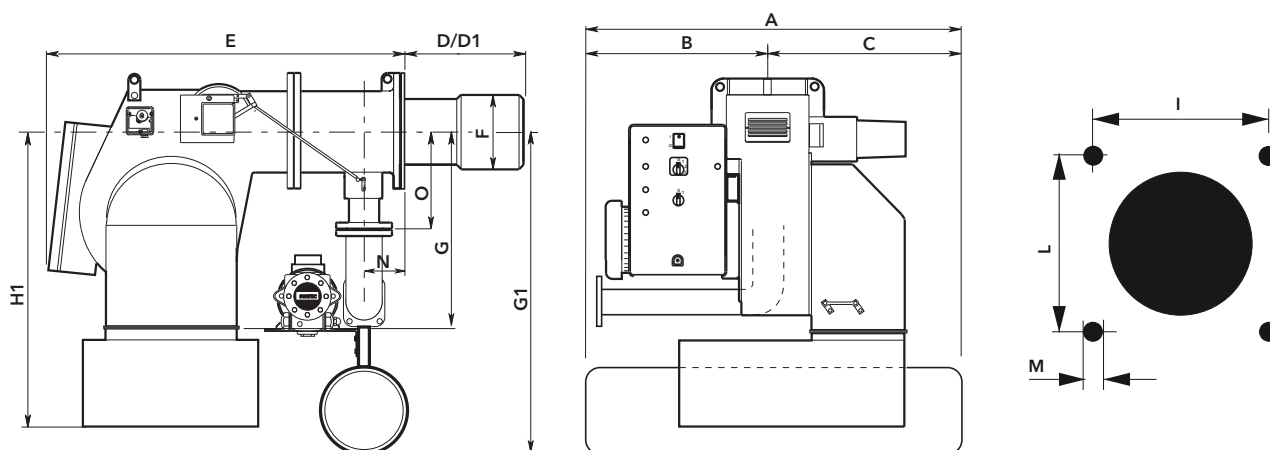

Model	A	B	C	D	D1	E	F	G	G1	H1*	N	O	I	L	M
GHO-TRON 5.5000 R	1358	680	678	354	554	1230	320	570	775	965	195	250	330	330	M16
GHO-TRON 5.5800 R	1358	680	678	354	554	1230	320	570	775	965	195	250	330	330	M16

* optional silencer

PACKAGING

The complete burner with combustion head is delivered in a single wooden box with gas train and filter, flexible hoses, boiler fixing accessories and technical documentation.

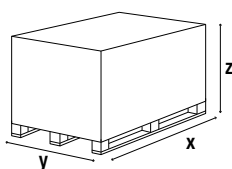

Model	Dimensions (mm)		
	X	Y	Z
GHO-TRON 5.5000 R	1580	1580	1050
GHO-TRON 5.5800 R	1580	1580	1050

GHO-TRON 6 R

1500 ... 13000 kW

Two stage progressive/modulating mechanical

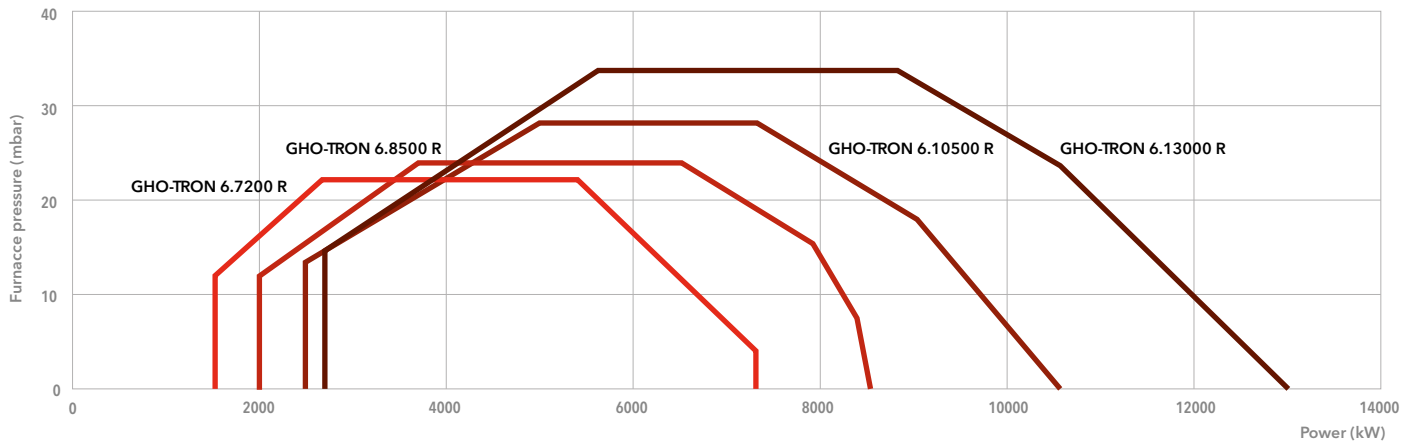

- **Fuels:** natural gas, Hi = 6,99 ... 11,39 kWh/Nm³;
heavy oil, viscosity 50°E at 50°C, Hi = 10,5...11,5 kWh/kg
- **Emission class:** Low NOx class 2 (≤120 mg/kWh) according to EN676 in gas
- **Protection level:** IP 42 (IP54 on request)

TECHNICAL DATA

	GHO-TRON 6.7200 R		GHO-TRON 6.8500 R		GHO-TRON 6.10500 R		GHO-TRON 6.13000 R	
Operating range	1500 - 7500 kW		2000 - 8500 kW		2500 - 10500 kW		2700 - 13000 kW	
Fuel flow	132 - 660 kg/h		176 - 750 kg/h		220 - 920 kg/h		240 - 1100 kg/h	
Nozzles	according to required power		according to required power		according to required power		according to required power	
Control box	LFL 1.333		LFL 1.333		LFL 1.333		LFL 1.333	
Fan motor	2800 rpm - 230/400 V 50 Hz - 15 kW		2800 rpm - 230/400 V 50 Hz - 18,5 kW		2800 rpm - 230/400 V 50 Hz - 22 kW		2800 rpm - 230/400 V 50 Hz - 37 kW	
Pump	TA 5C		TA 5C		T5 + TV		T5 + TV	
Resistance on pre-heaters	30 kW		30 kW		44 kW		60 kW	
Head length	KN	KL	KN	KL	KN	KL	KN	KL
Complete burner code	on request	on request	on request	on request	on request	on request	on request	on request

i Dimensions of gas trains and gas filters: see page 314

DIMENSIONS (mm)

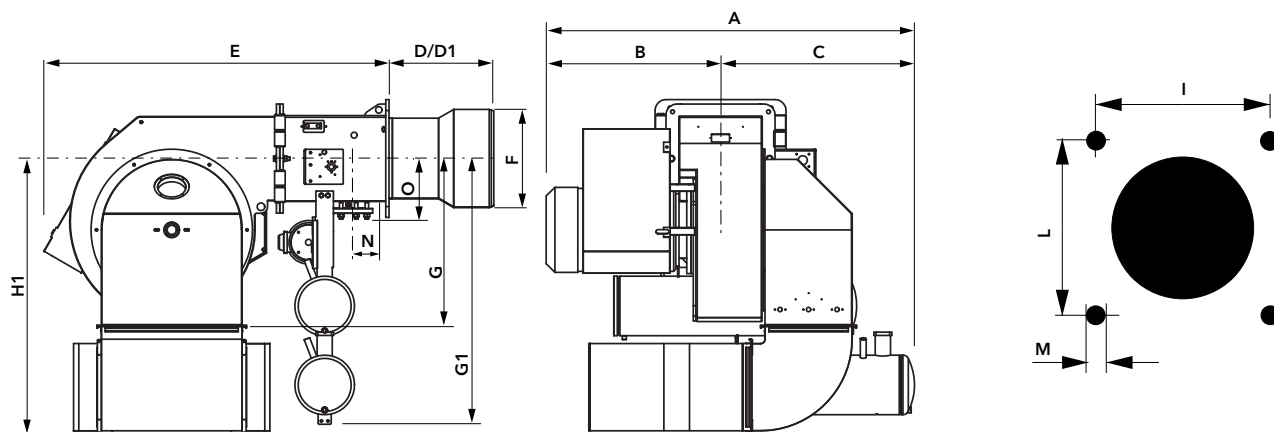

Model	A	B	C	D	E	F	G	G1	H1*	N	O	I	L	M
GHO-TRON 6.7200 R	1370	740	630	470	1640	420	775	850	1270	195	232	460	460	M20
GHO-TRON 6.8500 R	1370	740	630	470	1640	420	775	850	1270	195	232	460	460	M20
GHO-TRON 6.10500 R	1500	740	760	470	1640	420	775	850	1270	195	232	460	460	M20
GHO-TRON 6.13000 R	1700	800	900	470	1640	450	775	1200	1270	195	232	460	460	M20

* optional silencer

PACKAGING

The complete burner with combustion head is delivered in a single wooden box with gas train and filter, flexible hoses, boiler fixing accessories and technical documentation.

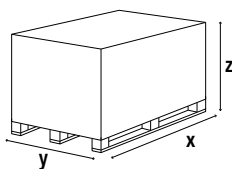

Model	Dimensions (mm)		
	X	Y	Z
GHO-TRON 6.7200 R	2400	1800	1600
GHO-TRON 6.8500 R	2400	1800	1600
GHO-TRON 6.10500 R	2400	1800	1600
GHO-TRON 6.13000 R	2400	1800	1600

GHO-TRON 7 R

3690 ... 17000 kW

Two stage progressive/modulating mechanical

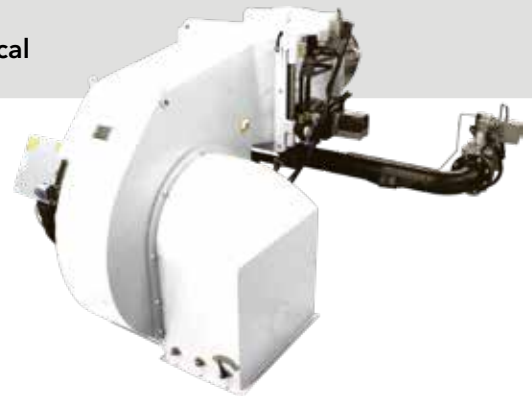

- **Fuels:** natural gas, Hi = 6,99 ... 11,39 kWh/Nm³;
heavy oil, viscosity 50°E at 50°C, Hi = 10,5...11,5 kWh/kg
- **Emission class:** Low NOx class 2 (≤ 120 mg/kWh) according to EN676 in gas
- **Protection level:** IP 42 (IP54 on request)

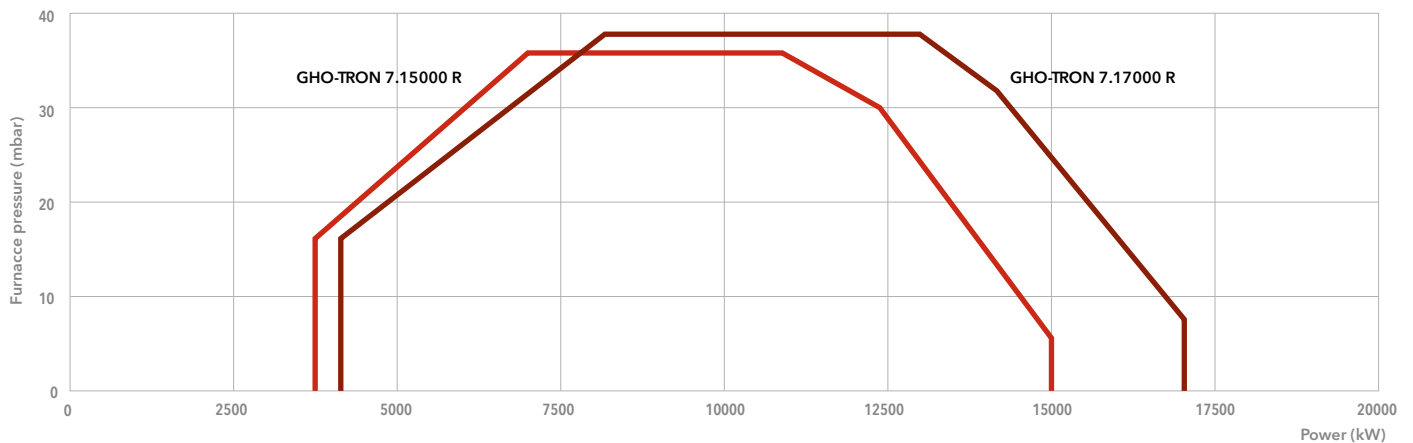
TECHNICAL DATA

	GHO-TRON 7.15000 R		GHO-TRON 7.17000 R	
Operating range	3690 - 15000 kW		4000 - 17000 kW	
Fuel flow	325 - 1320 kg/h		350 - 1495 kg/h	
Nozzles	according to required power		according to required power	
Control box	LFL 1.333		LFL 1.333	
Fan motor	2800 rpm - 230/400 V - 50 Hz - 45 kW		2800 rpm - 230/400 V - 50 Hz - 55 kW	
Pump	T5 + TV		T5 + TV	
Resistance on pre-heaters	75 kW		75 kW	
Head length	KN	KL	KN	KL
Complete burner code	on request	on request	on request	on request

i Dimensions of gas trains and gas filters: see page 314

DIMENSIONS (mm)

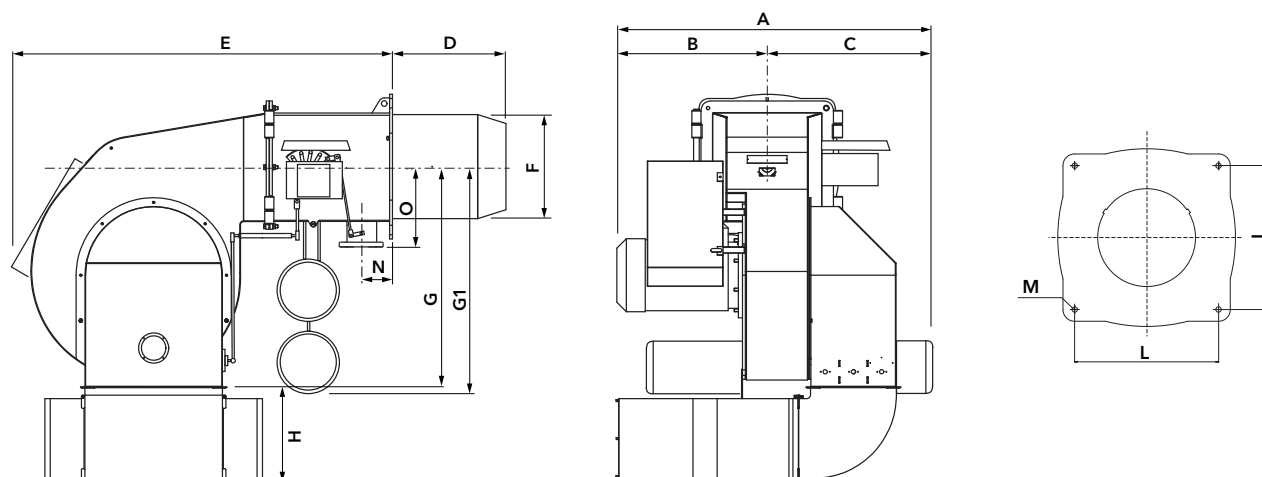

Model	A	B	C	D	E	F	G	G1	H*	N	O	I	L	M
GHO-TRON 7.15000 R	1948	860	1088	590	1910	550	1167	1220	530	210	320	620	620	M20
GHO-TRON 7.17000 R	1948	860	1088	590	1910	550	1167	1220	530	210	320	620	620	M20

* optional silencer

PACKAGING

The complete burner with combustion head is delivered in a single wooden box with gas train and filter, flexible hoses, boiler fixing accessories and technical documentation.

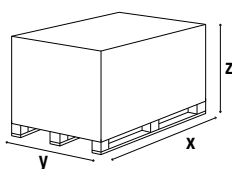

Model	Dimensions (mm)		
	X	Y	Z
GHO-TRON 7.15000 R	2800	2100	2000
GHO-TRON 7.17000 R	2800	2100	2000

DUOBLOCK

DUOBLOCK BURNERS FROM 230 TO 80000 kW

GAS, LIGHT OIL, HEAVY OIL AND DUAL FUEL



ALL THE BENEFITS OF THE SEPARATE VENTILATION

In contrast to monoblock burners, duoblock burners are made up of two units, or blocks, as the name implies: the burner head with the air inlet, and the separately-installed fan; the two units are connected via an air duct.

The separate installation of the fan offers several benefits:

- the fan can be installed in a separate room, for instance in the cellar; this results in considerably lower noise levels in the boiler room;
- less space required in front of the boiler and in the combustion chamber;
- individual fan layout with optimum adaptation of the fan characteristic curve to suit the pressure ratio of the heat generator; this guarantees pulsation-free and stable burner behaviour, even on heat generators with high resistance on the exhaust side;
- combustion air can be pre-heated to increase installation efficiency;
- lower weight loading on the boiler front.

EXTREME FLEXIBILITY AND VERSATILITY

ELCO duoblock burners are designed to satisfy the widest range of needs and can be applied to the most various type of civil and industrial solutions like fire-tube boilers, water-tube boilers, dryers and melting furnaces.

These burners enable installation to realize a modular and flexible combustion solution with a high degree of personalization. This results in a high performance installations at the lowest running cost.

The burners are built to be connected to an external air supply and can be supplied together with built-in or separate control panel, electronic or mechanical adjustment, flue gas recirculation, heavy oil pump unit and heating unit.

A COMPLETE RANGE OF OPTIONS

ELCO is able to offer an extremely wide range of industrial duoblock burners thanks to its well-known series, EK-DUO, RPD, D-TRON, and the new RPD N range, covering a power range from 230 kW up to 80 MW.

This range of burners is able to fulfill high capacity and high turndown needs and allows installation in very high pressurized combustion chambers.

All duoblock models can work with pre-heated combustion air up to 200°C and can be used in order to achieve greater values of efficiency.

Versions suitable to work with hydrogen and other alternative fuels are available on request.

RANGE OVERVIEW



D-TRON

MAIN TECHNICAL FEATURES

- Two stages and progressive/modulating forced draught burners, designed to be connected to an external air supply
- Fuels: natural gas, light oil, heavy oil; other fuels on request;
- Max inlet air temperature: 200°C (versions suitable to work with temperature up to 250°C in order to achieve greater values of efficiency are also available according to feasibility);
- Electrical switch cabinet manufactured in different configurations assembled on the burner or delivered separately and includes the burner control:
 - control box for burner operation sequences;
 - contactors and remote overload cut-out for control of the fan unit;
 - fuse to protect the auxiliary equipment;
 - switches, warning and information lights, manual power control;
 - ready to accept PID power regulator (option)
- Gas train factory assembled and tested for tightness and electrical security
- Electronic version available on request

EK-DUO

MAIN TECHNICAL FEATURES

- Progressive/modulating forced draught burners, designed to be connected to an external air supply
- Fuels: natural gas, light oil; other fuels on request;
- Flame tube length according to installation
- Secured burner head adjustments during maintenance
- Closing of the air damper on burner shutdown
- Control box: built-in or external according to customer requirements
- Gas train factory assembled and tested for tightness and electrical security

RPD

MAIN TECHNICAL FEATURES

- Progressive/modulating forced draught burner with register, designed to be connected to an external air supply
- Fuels: natural gas, light oil, heavy oil, hydrogen; other fuels and co-combustion of various fuels or to eliminate liquid waste on request
- Air/gas ratio with Etamatic digital control box
- Adjustable flame length with air registers
- Flame tube length according to installation
- Closing of the air damper on burner shutdown
- Control box: built-in or external according to customer requirements
- Gas train factory assembled and tested for tightness and electrical security

RPD N

MAIN TECHNICAL FEATURES

- Progressive/modulating forced draught burner with register, designed to be connected to an external air supply
- Fuels: natural gas; other fuels on request
- Flexible and modular burner concept with reduced weight and product complexity compared to the RPD range
- Adjustable flame length with air registers
- New combustion head design with sliding components to change the length of the head
- New standardized design of the switch cabinet in order to offer a more industrial and flexible solution to the end user
- Closing of the air damper on burner shutdown
- Control box: built-in or external according to customer requirements
- Gas train factory assembled and tested for tightness and electrical security

D-TRON 2 ... 9

230 ... 42000 kW

Two stages, two stage progressive/modulating mechanical or electronic



- **Fuels:** natural gas, Hi = 6,99 ... 11,39 kWh/Nm³;
light oil, viscosity 6 mm²/s at 20°C, Hi = 11,86 kWh/kg;
heavy oil, viscosity 20...350 mm²/s at 50°C;
other fuels on request
- **Emission class:** Low NOx class 3 models (in gas) available on request;
Versions with FGR System (≤30 mg/kWh) also available on request
- **Protection level:** IP 41 (IP 54 and IP 65 on request)

RANGE OVERVIEW

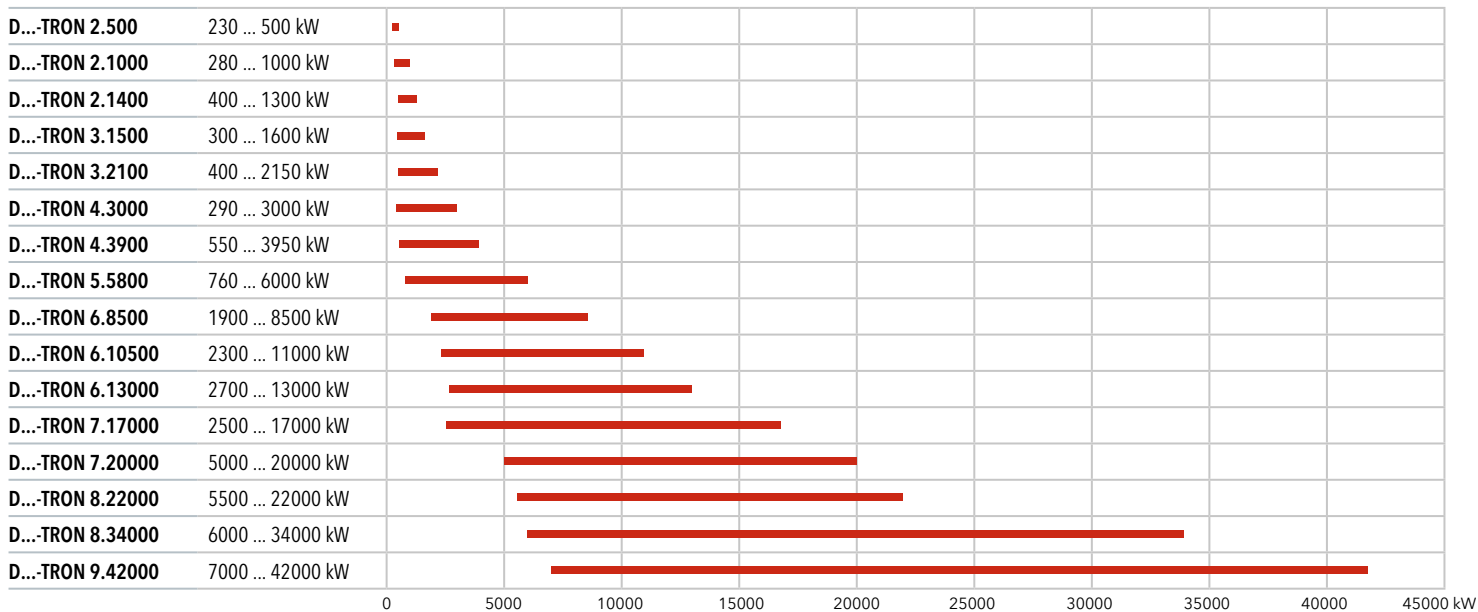

AVAILABLE CONFIGURATIONS

Model	Gas DG-TRON		Gas/light oil DGL-TRON			Light oil DL-TRON			Heavy oil DO-TRON	Gas/heavy oil DGO-TRON
	Progressive mechanical or electronic		Two stages	Progressive mechanical or electronic		Two stages	Progressive mechanical or electronic		Progressive mechanical or electronic	Progressive mechanical or electronic
	Class 2	Low NOx Class 3	Class 2	Class 2	Low NOx Class 3	Class 2	Class 2	Low NOx Class 3	-	Class 2 in gas
D...-TRON 2.500	●	●								
D...-TRON 2.1000	●	●	●							
D...-TRON 2.1400	●		●							
D...-TRON 3.1500		●								
D...-TRON 3.2100	●	●	●	●	○	●	●	○	●	
D...-TRON 4.3000	●	●		●	○		●	○	●	●
D...-TRON 4.3900	●	●		●	○		●	○	●	●
D...-TRON 5.5800	●	●		●	○		●	○	●	●
D...-TRON 6.8500	●	●		●	○		●	○	●	●
D...-TRON 6.10500	●	●		●	○		●	○	●	●
D...-TRON 6.13000	●	●		●	○		●	○	●	●
D...-TRON 7.17000	●	●		●	○		●	○	●	●
D...-TRON 7.20000		●								
D...-TRON 8.22000		●								
D...-TRON 8.34000		●								
D...-TRON 9.42000		●								

- : Standard versions
- : Models available on request



DIMENSIONS (mm)

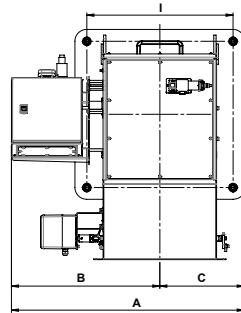
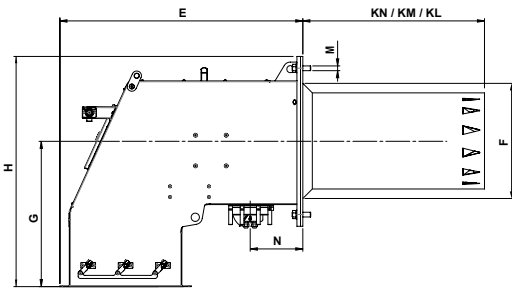

Connecting flange
D...-TRON 2...6

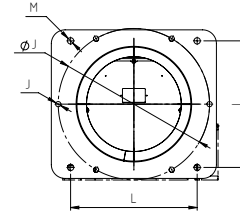

D...-TRON 7...9

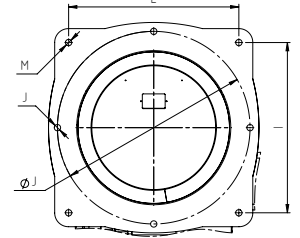

Model	A	B	C	KN	KM	KL	E	F	G	H	I	L	M	N
D...-TRON 2.500	523	307	216	205	284	394	556	160	290	415	185/200	185/200	4xM10	140*
D...-TRON 2.1000	523	307	216	205	284	394	556	190	290	415	185/200	185/200	4xM10	140*
D...-TRON 2.1400	523	307	216	345	445	545	556	200	290	415	185/200	185/200	4xM10	140*
D...-TRON 3.1500	620	376	373	345	445	545	556	205	290	415	185/200	185/200	4xM10	140*
D...-TRON 3.2100	584	420	164	345	445	545	637	224	379	545	270	270	4xM16	125
D...-TRON 4.3000	623	440	183	400	540	640	650	263	375	545	270	270	4xM16	125
D...-TRON 4.3900	746	530	216	400	550	640	798	310	392	587	315	315	4xM16	190
D...-TRON 5.5800	746	536	210	450	560	690	847	325	409	619	330	330	4xM16	195
D...-TRON 6.8500	907	602	305	490	630	770	802	377	480	760	485	485	4xM20	195
D...-TRON 6.10500	998	638	360	490	640	790	1040	420	556	889	620	620	4xM20	195
D...-TRON 6.13000	998	638	360	490	640	790	1030	440	622	982	620	620	4xM20	195
D...-TRON 7.17000	1056	673	383	590	710	810	1480	497	676	982	620	620	4xM20	210
D...-TRON 7.20000	1099	706	393	640	760	810	1054	580	653	1055	695	695	4xM20	210
D...-TRON 8.22000	1307	835	472	640	760	850	1549	712	767	1248	800	800	4xM20	400
D...-TRON 8.34000	1307	835	472	700	850	950	1549	712	767	1248	800	800	4xM20	400
D...-TRON 9.42000	1508	918	590	700	850	950	1519	855	900	1490	1020	1020	4xM20	400

*: gas train connection on the right side of the burner up to the model D...-TRON 3.1500

Air duct

2.500...4.3000

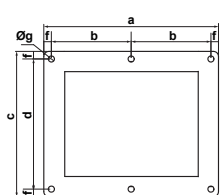

4.3900...6.8500

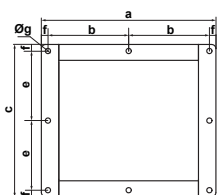

6.10500/130000

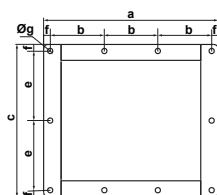

7.17000/20000

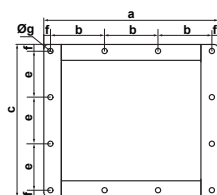

8.22000/34000

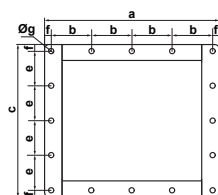

9.4200

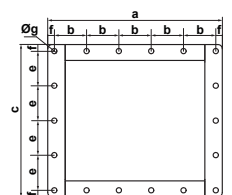

Model	a	b	c	d	e	f	Øg
D...-TRON 2.500...3.1500	303	136,5	252	222	-	15	6x R12
D...-TRON 3.2100/4.3000	345	157,5	287	257	-	15	6x R12
D...-TRON 4.3900	400	185	349	-	159,5	15	8x R12
D...-TRON 5.5800	470	220	361	-	165,5	15	8x R12
D...-TRON 6.8500	506	234	402	-	182	19	10x R14
D...-TRON 6.10500	557	173	474	-	218	19	10x R14
D...-TRON 6.13000	557	173	561	-	261,5	19	10x R14
D...-TRON 7.17000	730	230,7	650	-	204	19	12x R14
D...-TRON 7.20000	696	226	614	-	192	19	12x R14
D...-TRON 8.22000/34000	930	223	828	-	197,5	19	16x R14
D...-TRON 9.42000	1042	200,8	828	-	197,5	19	18x R14

! Drawings and dimensions (in mm) make reference to a Low NOx class 3 burner in electronic version: they are shown for informational purposes only and may vary according to the chosen configuration

EK-DUO 2 ... 4

600 ... 16000 kW

Two stage progressive/modulating electronic



- **Fuels:** natural gas, Hi = 6,99 ... 11,39 kWh/Nm³;
light oil, viscosity 6 mm²/s at 20°C, Hi = 11,86 kWh/kg;
other fuels on request
- **Emission class:** Low NOx class 3 (≤80 mg/kWh) according to EN676 in gas and
Low NOx class 3 (≤120 mg/kWh) according to EN267 in light oil
Versions with FGR System (≤30 mg/kWh) also available on request
- **Protection level:** IP 41 (IP 54 and IP 65 on request)

RANGE OVERVIEW

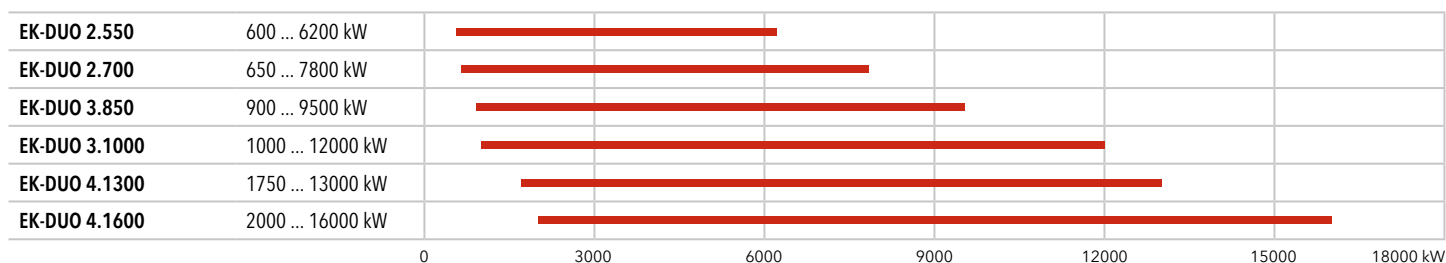

AVAILABLE CONFIGURATIONS

Model	Weight (kg)	Fuel			Operation	NOx emissions
		Gas	Gas/Light oil	Light oil	Electronic	Low NOx class 3
EK-DUO 2.550	320 ... 400	●	●	●	●	●
EK-DUO 2.700	320 ... 400	●	●	●	●	●
EK-DUO 3.850	400 ... 470	●	●	●	●	●
EK-DUO 3.1000	400 ... 470	●	●	●	●	●
EK-DUO 4.1300	400 ... 420	●	●	●	●	●
EK-DUO 4.1600	400 ... 420	●	●	●	●	●

DIMENSIONS (mm)

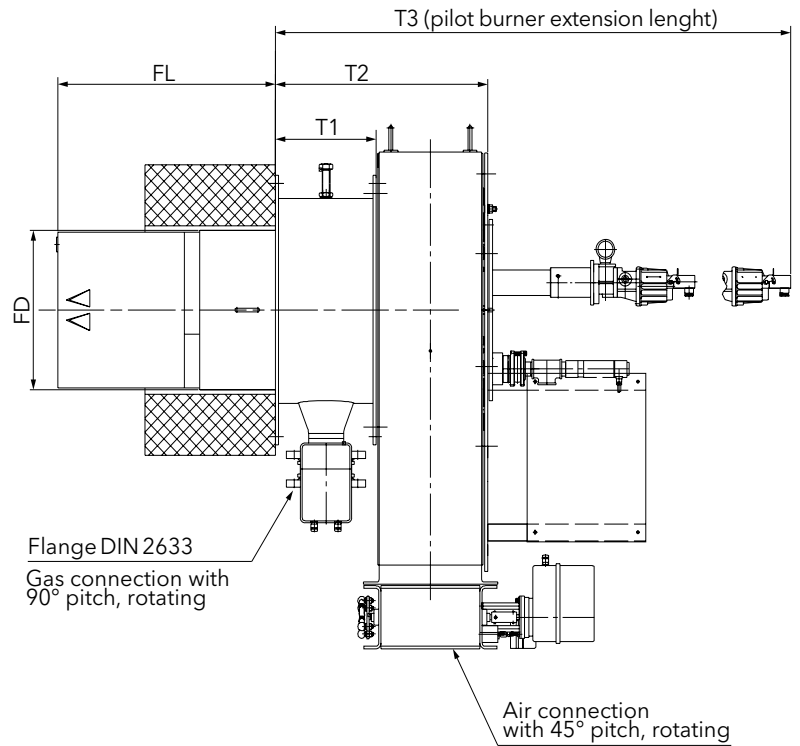
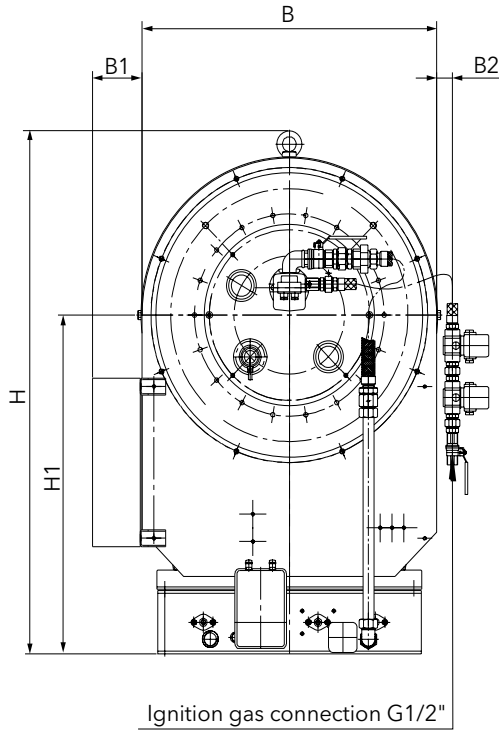

Air connection flange

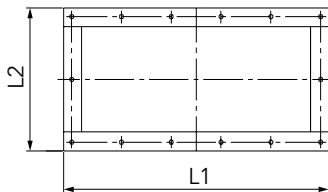

Details of boiler front plate

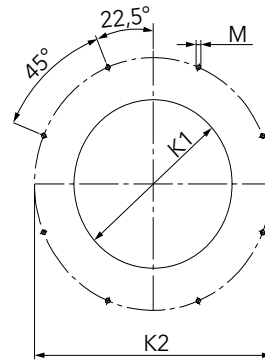

Model	Gas connection	H	H1	B	B1	B2*	T1	T2	T3*	FL*	FD*	L1	L2	K1	K2	M
EK-DUO 2.550	DN80	1241	804	750	125	40	255	537	2005 ... 2150	320 ... 570	378	670	340	400	600	M12
EK-DUO 2.700	DN80	1241	804	750	125	40	255	537	2005 ... 2150	320 ... 570	378	670	340	400	600	M12
EK-DUO 3.850	DN80	1481	944	950	120	40	290	622	1810 ... 2390	350 ... 590	441 ... 456	827	386	480	690	M12
EK-DUO 3.1000	DN80	1481	944	950	120	40	290	622	1810 ... 2390	350 ... 590	441 ... 456	827	386	480	690	M12
EK-DUO 4.1300	DN100	1491	929	1000	122	40	420	802	2600 ... 2770	350 ... 620	506	840	440	525	725	M20
EK-DUO 4.1600	DN100	1491	929	1000	122	40	420	802	2600 ... 2770	350 ... 620	506	840	440	525	725	M20

Drawings and dimensions make reference to a standard burner version: they are shown for informational purposes only and may vary according to the chosen configuration.

RPD 20 ... 160

500 ... 80000 kW

Two stage progressive/modulating electronic

- **Fuels:** natural gas, Hi = 6,99 ... 11,39 kWh/Nm³;
light oil, viscosity 6 mm²/s at 20°C, Hi = 11,86 kWh/kg;
heavy oil, viscosity 20...350 mm²/s at 50°C;
hydrogen and other fuels on request;
co-combustion of various fuels or to eliminate liquid waste on request
- **Emission class:** Low NOx class 3 (≤80 mg/kWh) or class 2 (≤120 mg/kWh) according to EN676 in gas;
Low NOx class 3 (≤120 mg/kWh) or class 2 (≤185 mg/kWh) according to EN267 in light oil
Versions with FGR System (≤30 mg/kWh) also available on request
- **Protection level:** IP 41 (IP 54 and IP 65 on request)



RANGE OVERVIEW

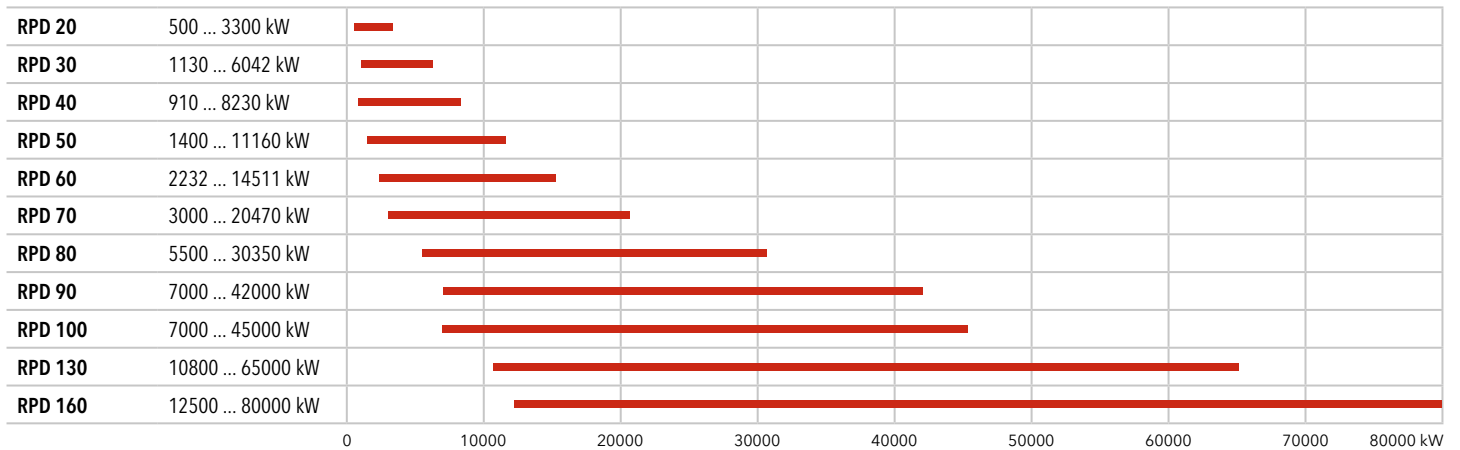

AVAILABLE CONFIGURATIONS

Model	Approx. weight (kg)	Fuel					Operation	NOx emissions	
		Gas	Gas/Light oil	Light oil	Heavy oil	Gas/Heavy oil		Class 2	Class 3
RPD 20	370	●	●	●	●	●	●	●	●
RPD 30	400	●	●	●	●	●	●	●	●
RPD 40	430	●	●	●	●	●	●	●	●
RPD 50	550	●	●	●	●	●	●	●	●
RPD 60	600	●	●	●	●	●	●	●	●
RPD 70	760	●	●	●	●	●	●	●	●
RPD 80	1060	●	●	●	●	●	●	●	●
RPD 90	1200	●	●	●	●	●	●	●	●
RPD 100	1250	●	●	●	●	●	●	●	●
RPD 130	2850	●	●	●	●	●	●	●	●
RPD 160	3080	●	●	●	●	●	●	●	●



DIMENSIONS (mm)

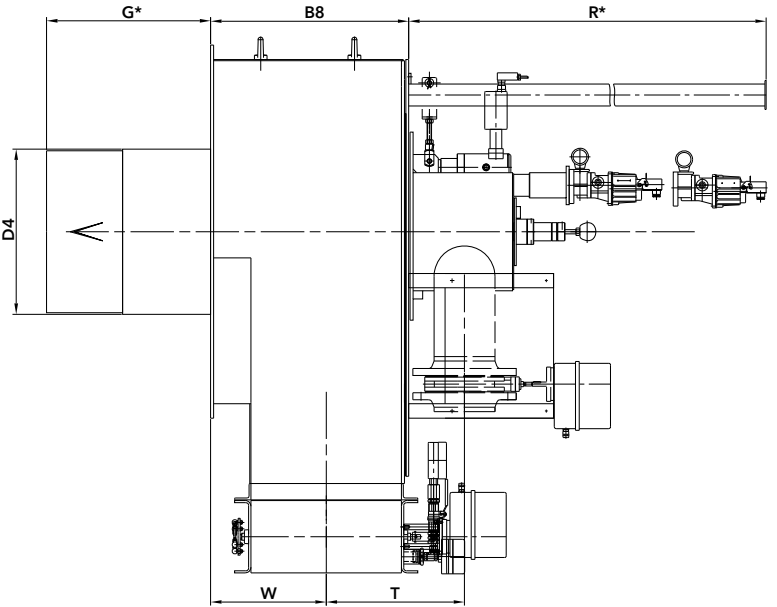
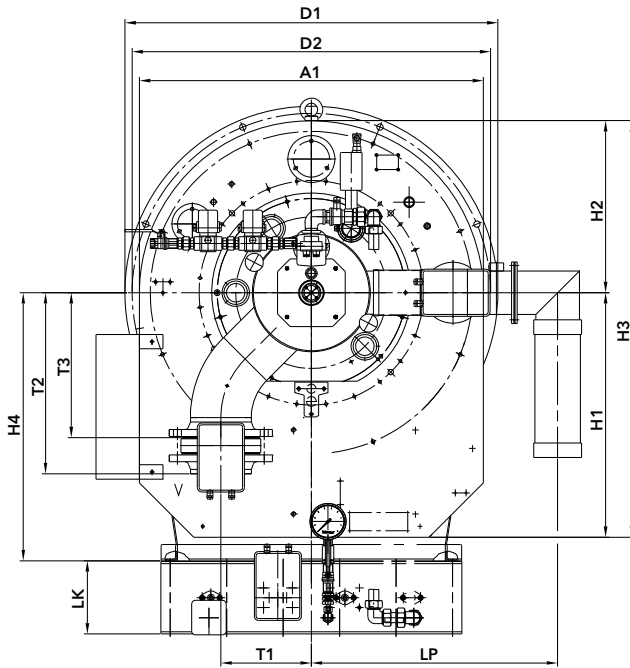

Air connection flange

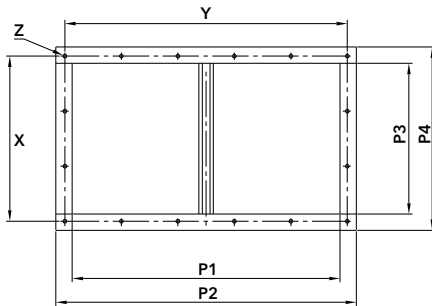

Details of boiler front plate

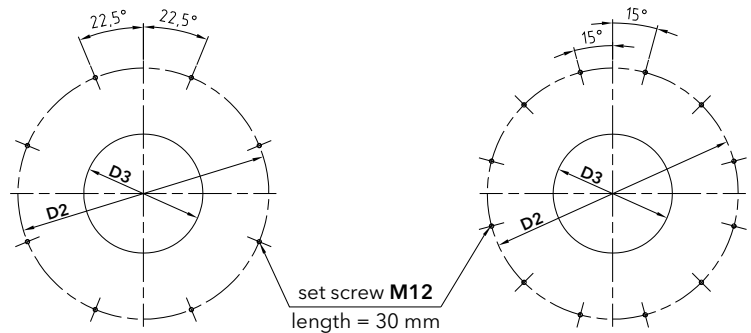

RPD 20 - 60

RPD 70 - 100

Model	A1	B8	D1	D2	D3	D4	D7	H1	H2	H3	H4	P1	P2	P3	P4	T	T1	T2	T3	V	W	X	Y	Z	LK	LP
RPD 20	values dependent on design variant																									
RPD 30	745	428	830	790	385	371	17,5	620	373	993	650	580	670	320	410	342	192	458	362	DN80	248	4x92	5x126	10	202	594
RPD 40	745	428	830	790	423	409	17,5	620	373	993	650	580	670	320	410	342	192	458	362	DN80	248	4x92	5x126	10	202	594
RPD 50	950	547	1030	990	470	456	17,5	675	475	1150	740	740	830	416	506	382	250	500	400	DN150	319	3x152	5x156	10	202	680
RPD 60	994	634	1080	1040	520	506	18	700	497	1197	825	750	840	470	560	439	270	520	420	DN150	379	4x129	5x160	10	202	704
RPD 70	1160	731	1240	1200	640	626	18	780	580	1360	900	936	1026	600	690	501	365	479	479	DN150	410	5x128	7x140	10	202	841
RPD 80	1350	860	1450	1400	740	710	18	820	675	1495	1000	1102	1192	700	790	561	310	647	547	DN150	489	6x125	9x128	10	202	909
RPD 90	1700	890	1800	1750	883	870	18	905	850	1755	1100	1300	1390	742	832	618	310	743	643	DN150	494	6x132	10x135	10	202	1043
RPD 100	1700	890	1800	1750	935	922	18	905	850	1755	1100	1300	1390	742	832	618	310	743	643	DN150	494	6x132	10x135	10	202	1043
RPD 130	values dependent on design variant																									
RPD 160	values dependent on design variant																									

*: value G and R are defined based on the coating of the boiler

Drawings and dimensions make reference to a standard burner version: they are shown for informational purposes only and may vary according to the chosen configuration.

RPD 70 N ... 160 N

3000 ... 80000 kW

Two stage progressive/modulating electronic



- **Fuels:** natural gas, Hi = 6,99 ... 11,39 kWh/Nm³;
- **Emission class:** Low NOx class 3 (≤80 mg/kWh) according to EN676 with U1 and U2 heads; Low NOx class 4 (≤60 mg/kWh) according to EN676 with FX heads; Versions with FGR System (≤30 mg/kWh) also available on request
- **Protection level:** IP 54 (IP 65 on request)

RANGE OVERVIEW

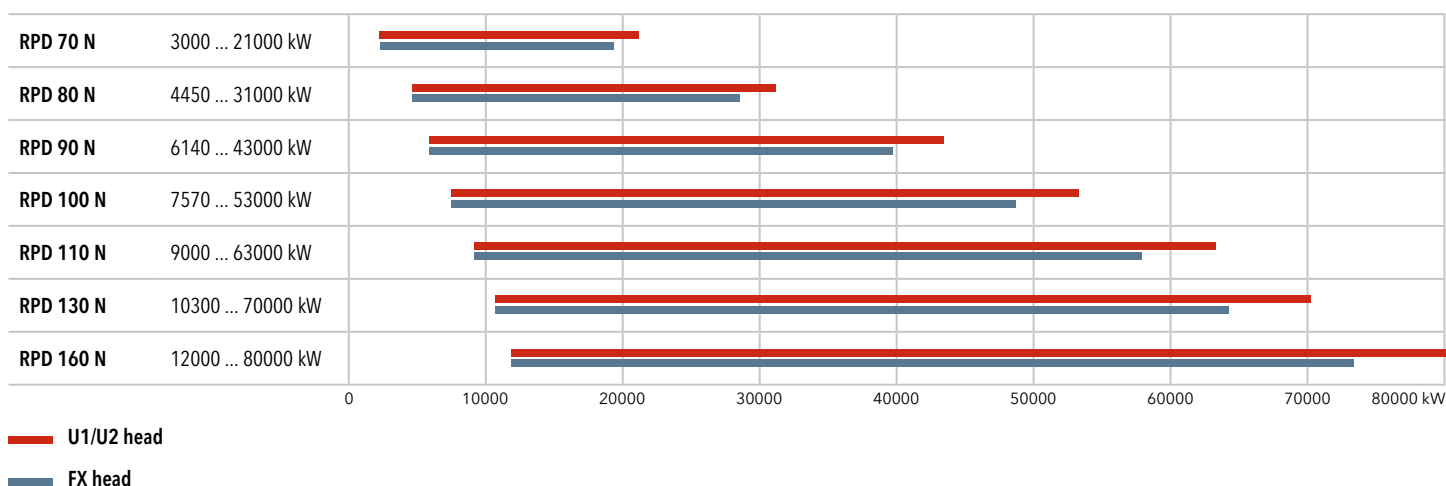

AVAILABLE CONFIGURATIONS

Model	Combustion head			
	Type	NOx emission	Sliding system	Primary air
RPD 70 N	U1/U2	80 mg/kWh	●	
	FX	50 mg/kWh		●
RPD 80 N	U1/U2	80 mg/kWh	●	
	FX	50 mg/kWh		●
RPD 90 N	U1/U2	80 mg/kWh	●	
	FX	50 mg/kWh		●
RPD 100 N	U1/U2	80 mg/kWh	●	
	FX	50 mg/kWh		●
RPD 110 N	U1/U2	80 mg/kWh	●	
	FX	50 mg/kWh		●
RPD 130 N	U1/U2	80 mg/kWh	●	
	FX	50 mg/kWh		●
RPD 160 N	U1/U2	80 mg/kWh	●	
	FX	50 mg/kWh		●

DIMENSIONS (mm)

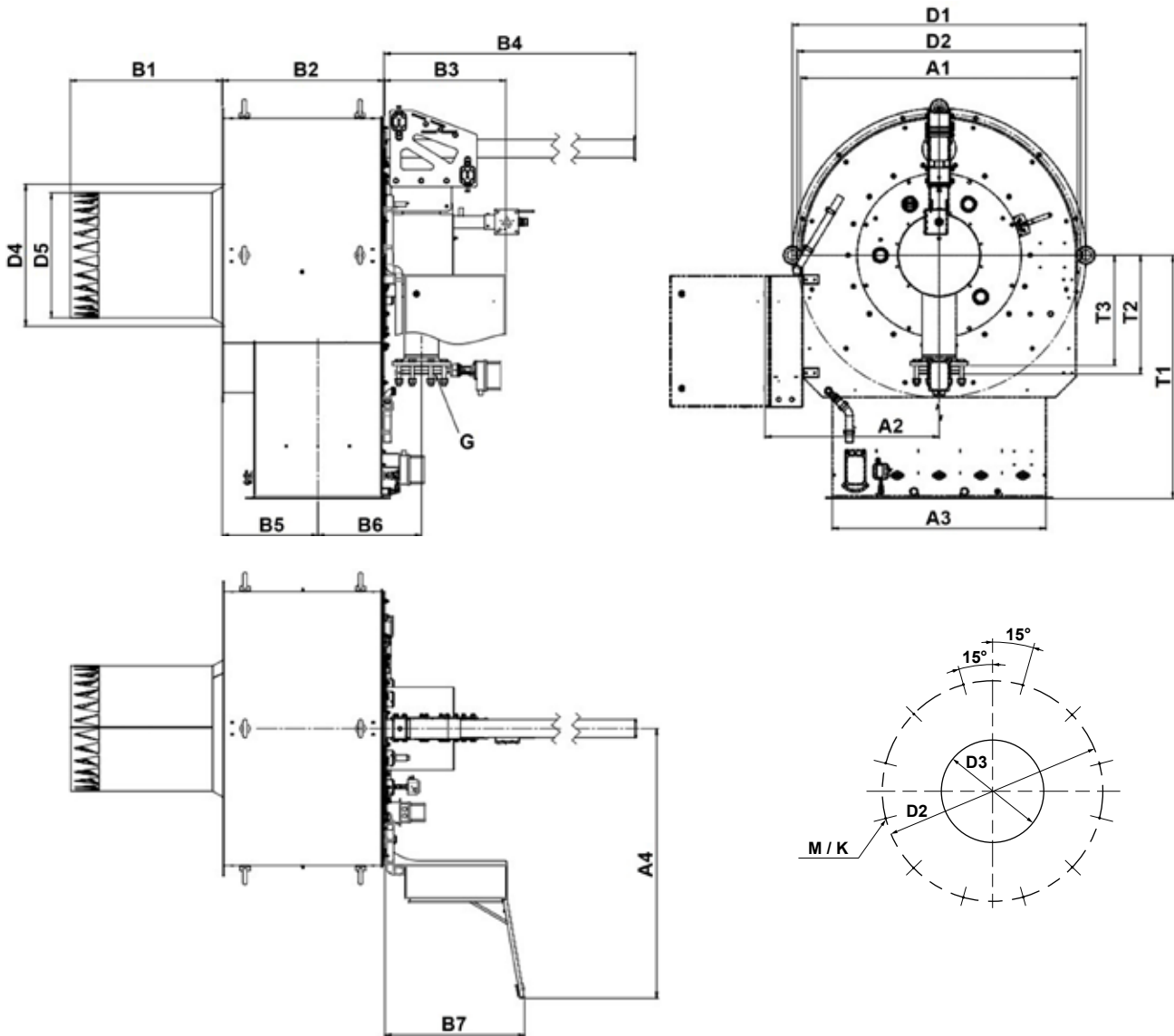

	A1	A2	A3	A4 ⁽¹⁾	D1	D2	D3	D4	D5	B1 ⁽²⁾			B2	B3	B4 ⁽³⁾	B5 ⁽⁴⁾	B6	B7	T1	T2	T3	G	M ⁽⁵⁾	K ⁽⁶⁾
										KN	KM	KL												
RPD 70 N	1368	860	1054	1330	1450	1400	750	727	617	600	750	900	799	600	2337	475	511	690	1200	586	544	DN150-P16	16	80
RPD 80 N									701															
RPD 90 N	1710	1035	1412	1501	1800	1750	995	985	856	850	1050	1250	1030	600	2843	590	669	690	1300	676	630	DN200-P16	16	80
RPD 100 N									906															
RPD 110 N									956															
RPD 130 N	2112	945	1624	1415	2210	2200	1190	1148	1063	1150	1145	600	3323	641	992	690	1386	696	650	DN200-P16	16	80		
RPD 160 N									1130															

! Note: dimensions are guidelines only and referred to the U1/U2 version. Dimensions of models equipped with FX burner head depends on the installation requirements.

- ⁽¹⁾: optional switch cabinet mounted on other burner side
- ⁽²⁾: other length on request
- ⁽³⁾: measure may differ in case of special combustion head length (B1)
- ⁽⁴⁾: with 3 mm sealing
- ⁽⁵⁾: stud screw dimension
- ⁽⁶⁾: stud screw length (with expansion sleeve 40mm)

GAS VALVE AND CONNECTION PIPE

PIC. 1A

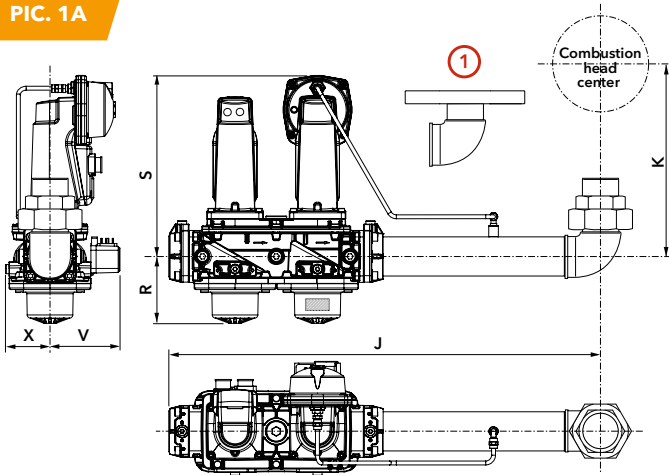

PIC. 1B

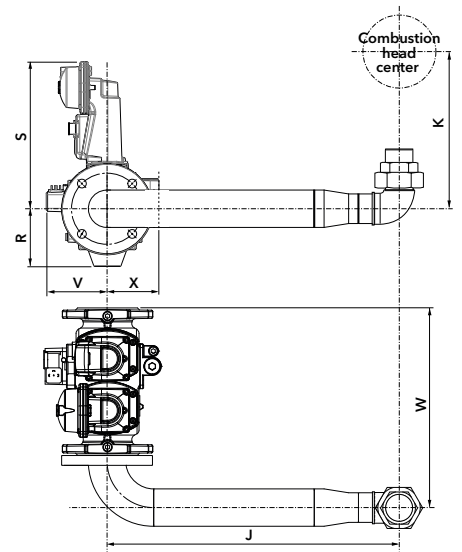

PIC. 1C

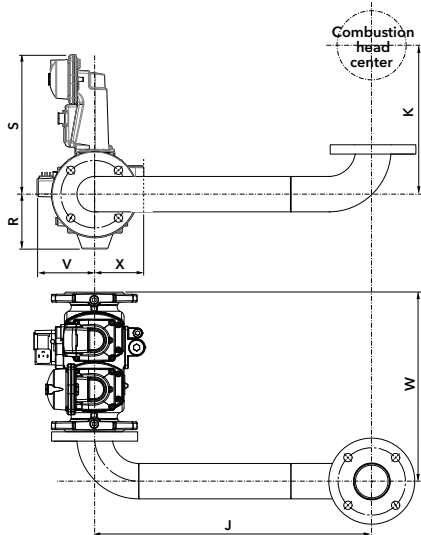

PIC. 2A

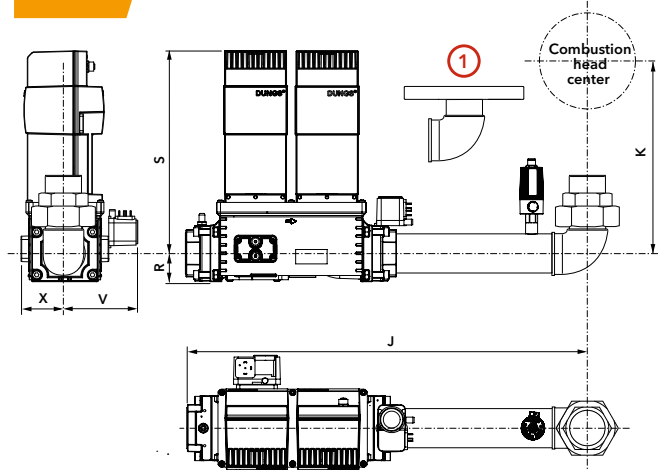

PIC. 2B

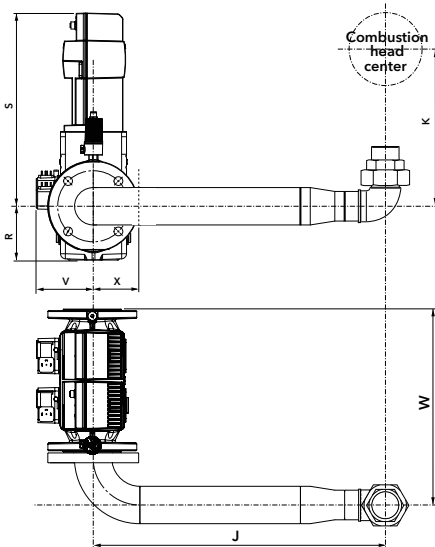

PIC. 2C

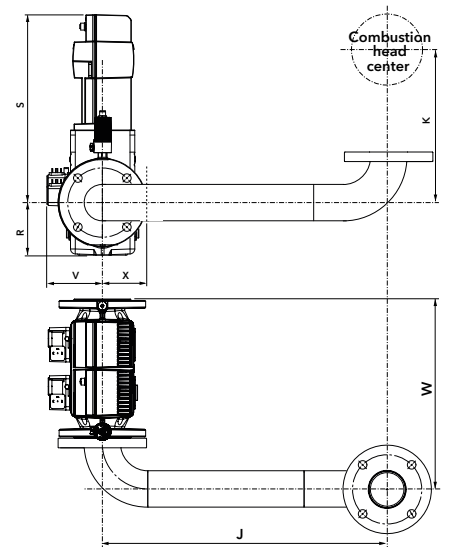

DIMENSIONS

Burner model	Gas valve model	Gas train code	Connection pipe code	Ø	Pic.	J	K	W	R	S	V	X
EK-TRON 5.300 G-E... EK-TRON 6.350 G-E...	VGD20.503	3148683	3144686	d2"	1A	650	355	-	103	279	108	68
	VGD40.065	3148684	3148771	DN65	1B	605	355	400	118	303	151	81
	VGD40.080	3148685	3148772	DN80	1B	605	355	440	132	313	148	88
	VGD40.100	3148686	3148773	DN100	1B	605	355	480	145	331	137	131
	MBE 050	3148693	3144686	d2"	2A	630	355	-	44	313	115	60
	MBE 065	3148694	3144686	DN65	2B	605	355	400	106	382	113	90
	MBE 080	3148695	3148772	DN80	2B	605	355	420	106	382	118	97
	MBE 100	3148696	3148773	DN100	2B	605	355	460	106	382	134	113
EK-TRON 6.400 G-E...	VGD20.503	3148683	3148770	s2"	1A Ⓢ	650	370	-	103	279	108	68
	VGD40.065	3148684	3145997	DN65	1C	670	370	410	118	303	151	81
	VGD40.080	3148685	3145864	DN80	1C	670	370	435	132	313	148	88
	VGD40.100	3148686	3145821	DN100	1C	670	370	480	145	331	137	131
	MBE 050	3148693	3148770	d2"	2A Ⓢ	630	355	-	44	313	115	60
	MBE 065	3148694	3145997	DN65	2C	670	370	415	106	382	113	90
	MBE 080	3148695	3145864	DN80	2C	670	370	435	106	382	118	97
	MBE 100	3148696	3145821	DN100	2C	670	370	475	106	382	134	113
EK-TRON 7.500 G-E... EK-TRON 7.600 G-E...	VGD20.503	3148683	3148770	s2"	1A Ⓢ	650	370	-	103	279	108	68
	VGD40.065	3148684	3148766	DN65	1C	780	375	420	118	303	151	81
	VGD40.080	3148685	3148767	DN80	1C	780	375	435	132	313	148	88
	VGD40.100	3148686	3148768	DN100	1C	780	375	480	145	331	137	131
	VGD40.125	3148687	3148769	DN125	1C	790	375	565	175	345	159	137
	MBE 050	3148693	3148770	d2"	2A Ⓢ	630	355	-	44	313	115	60
	MBE 065	3148694	3145997	DN65	2C	780	375	415	106	382	113	90
	MBE 100	3148696	3145821	DN100	2C	780	375	480	106	382	134	113
EK-TRON 5.300 G-R... EK-TRON 6.350 G-R...	VGD20.503	3148688	3144686	d2"	1A	650	355	-	103	279	108	68
	VGD40.065	3148689	3148771	DN65	1B	605	355	400	118	303	151	81
	VGD40.080	3148690	3148772	DN80	1B	605	355	440	132	313	148	88
	VGD40.100	3148691	3148773	DN100	1B	605	355	480	145	331	137	131
	MBE 050	3148697	3144686	d2"	2A	630	355	-	44	313	115	60
	MBE 065	3148698	3148771	DN65	2B	605	355	400	106	382	113	90
	MBE 080	3148699	3148772	DN80	2B	605	355	420	106	382	118	97
	MBE 100	3148700	3148773	DN100	2B	605	355	460	106	382	134	113
EK-TRON 6.400 G-R...	VGD20.503	3148688	3148770	s2"	1A Ⓢ	650	370	-	103	279	108	68
	VGD40.065	3148689	3145997	DN65	1C	670	370	410	118	303	151	81
	VGD40.080	3148690	3145864	DN80	1C	670	370	435	132	313	148	88
	VGD40.100	3148691	3145821	DN100	1C	670	370	480	145	331	137	131
	MBE 050	3148697	3148770	d2"	2A Ⓢ	630	355	-	44	313	115	60
	MBE 065	3148698	3145997	DN65	2C	670	370	415	106	382	113	90
	MBE 080	3148699	3145864	DN80	2C	670	370	435	106	382	118	97
	MBE 100	3148700	3145821	DN100	2C	670	370	475	106	382	134	113
EK-TRON 7.500 G-R... EK-TRON 7.600 G-R...	VGD20.503	3148688	3148770	s2"	1A Ⓢ	650	370	-	103	279	108	68
	VGD40.065	3148689	3148766	DN65	1C	780	375	420	118	303	151	81
	VGD40.080	3148690	3148767	DN80	1C	780	375	435	132	313	148	88
	VGD40.100	3148691	3148768	DN100	1C	780	375	480	145	331	137	131
	VGD40.125	3148692	3148769	DN125	1C	790	375	565	175	345	159	137
	MBE 050	3148697	3148770	d2"	2A Ⓢ	630	355	-	44	313	115	60
	MBE 065	3148698	3145997	DN65	2C	780	375	415	106	382	113	90
	MBE 100	3148700	3145821	DN100	2C	780	375	480	106	382	134	113

GAS VALVE AND CONNECTION PIPE

PIC. 1A

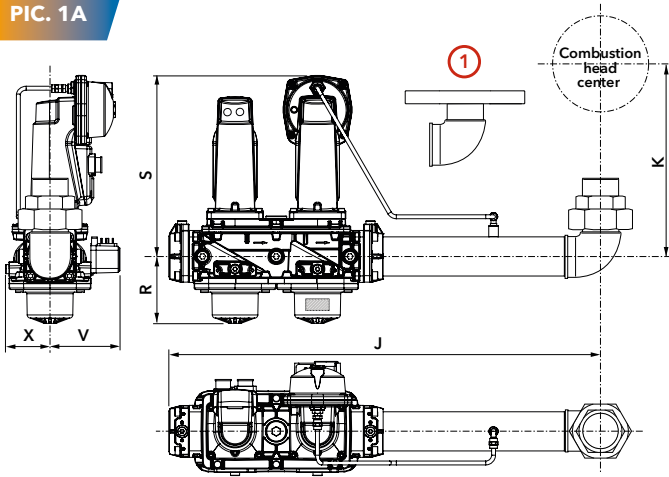

PIC. 1B

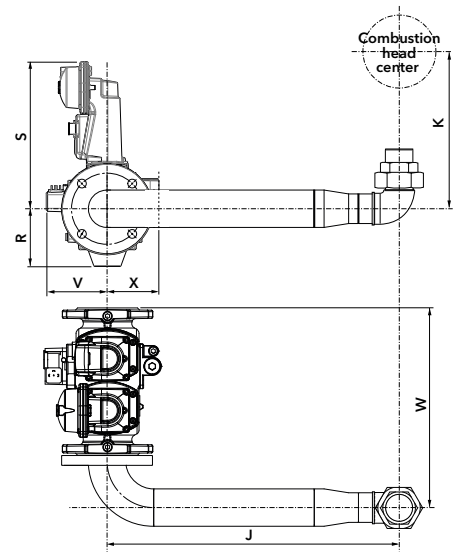

PIC. 1C

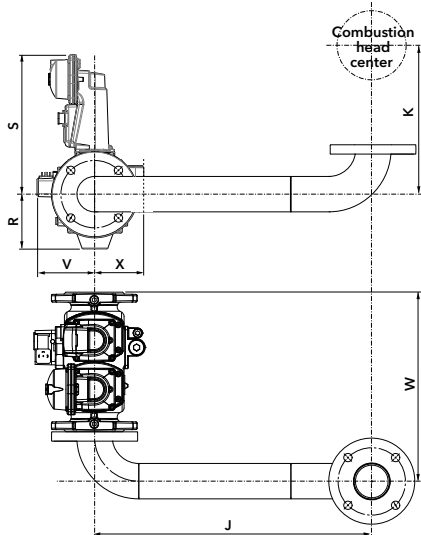

PIC. 2A

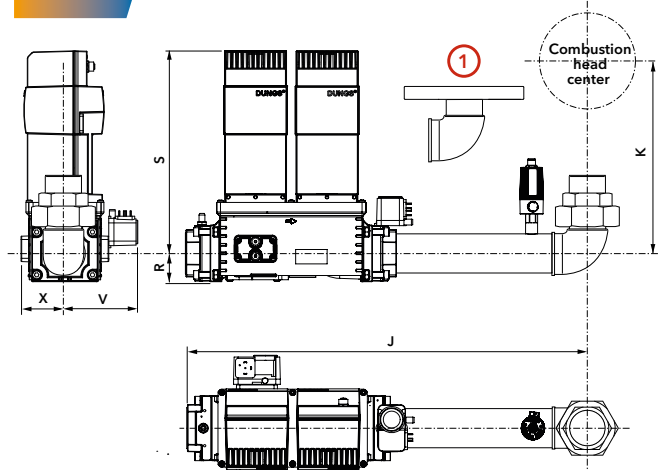

PIC. 2B

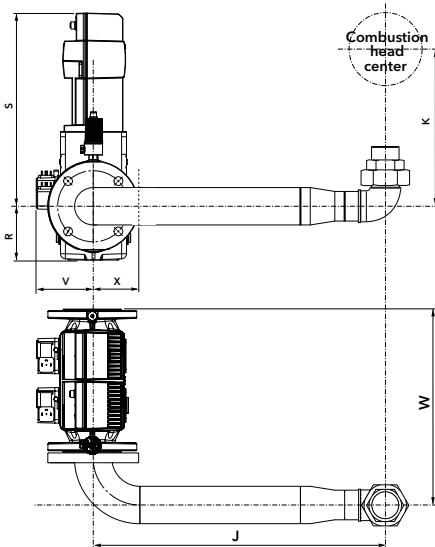

PIC. 2C

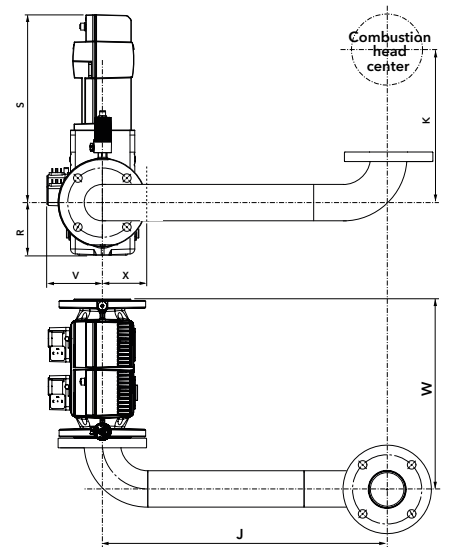

DIMENSIONS

Burner model	Gas valve model	Gas train code	Connection pipe code	Ø	Pic.	J	K	W	R	S	V	X
EK-TRON 5.170 GL-EX2	VGD20.503	3148683	3144686	d2"	1A	650	355	-	103	279	108	68
	VGD40.065	3148684	3148771	DN65	1B	605	355	400	118	303	151	81
	VGD40.080	3148685	3148772	DN80	1B	605	355	440	132	313	148	88
	MB-DLE 415	3149611	3144686	d1"1/2	2D	629	355		79	169	94	56
	MB-DLE 420	3149612	3144686	d2"	2D	629	355	-	76	220	94	56
EK-TRON 5.200 GL-EX2	VGD20.503	3148683	3144686	s2"	1A	650	355	-	103	279	108	68
	VGD40.065	3148684	3148771	DN65	1B	605	355	400	118	303	151	81
	VGD40.080	3148685	3148772	DN80	1B	605	355	440	132	313	148	88
	MB-DLE 420	3149612	3144686	d2"	2D	629	355	-	76	220	94	56
EK-TRON 6.350 GL-EX2	VGD20.503	3148683	3144686	s2"	1A	650	355	-	103	279	108	68
	VGD40.065	3148684	3148771	DN65	1B	605	355	400	118	303	151	81
	VGD40.080	3148685	3148772	DN80	1B	605	355	440	132	313	148	88
	VGD40.100	3148686	3148773	DN100	1B	605	355	480	145	331	137	131
	MBE 050	3148693	3144686	d2"	2A	630	355	-	44	313	115	60
	MBE 065	3148694	3148771	DN65	2B	605	355	400	106	382	113	90
	MBE 080	3148695	3148772	DN80	2B	605	355	420	106	382	118	97
MBE 100	3148696	3148773	DN100	2B	605	355	460	106	382	134	113	
EK-TRON 6.400 GL-EX2	VGD20.503	3148683	3148770	s2"	1A ①	650	370	-	103	279	108	68
	VGD40.065	3148684	3148766	DN65	1C	670	370	410	118	303	151	81
	VGD40.080	3148685	3148767	DN80	1C	670	370	435	132	313	148	88
	VGD40.100	3148686	3148768	DN100	1C	670	370	480	145	331	137	131
	MBE 050	3148693	3148770	d2"	2A ①	630	355	-	44	313	115	60
	MBE 065	3148694	3148766	DN65	2C	670	370	415	106	382	113	90
	MBE 080	3148695	3148767	DN80	2C	670	370	435	106	382	118	97
	MBE 100	3148696	3148768	DN100	2C	670	370	475	106	382	134	113

DUNGS

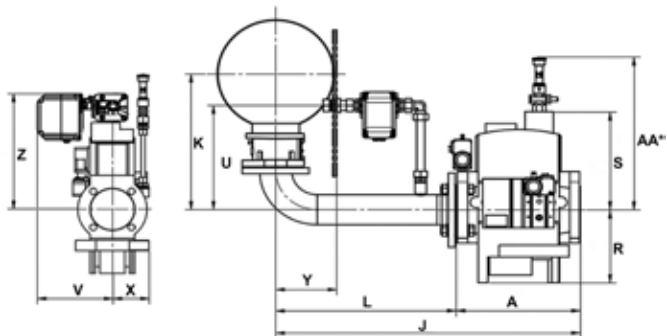

DUNGS basic gas trains delivery scope and description:

- gas compact unit MBC
- minimum gas pressure switch
- fittings between burner and gas train

i Configuration with gas inlet from the right side (left side on request)

DUNGS gas trains		
Designation	Type	Code
GT-d706-1"1/2 ⁽¹⁾	Threaded design	3759629
GT-d705-2" ⁽¹⁾	Basic version	3759628
GT-d701-65	Flanged design Basic version	3759625
GT-d702-80		3759626
GT-d703-100		3759627

Dimensions	V	X	Z	K	U	J	L	A	Y	R	S	AA ⁽²⁾
GT-d706-1"1/2	210	57	351	404	311	683	500	203	169	80	185	316
GT-d705-2"	210	53	355	434	341	757	500	281	169	53	351	358
GT-d701-65	210	98	329	382	289	792,5	500	290	169	183	246	384
GT-d702-80	210	108	348	402	309	812	500	310	169	205	292	272
GT-d703-100	210	125	348	402	309	856	502	352	169	250	329	275

⁽¹⁾: model with integrated filter

⁽²⁾: in PED configuration

SIEMENS

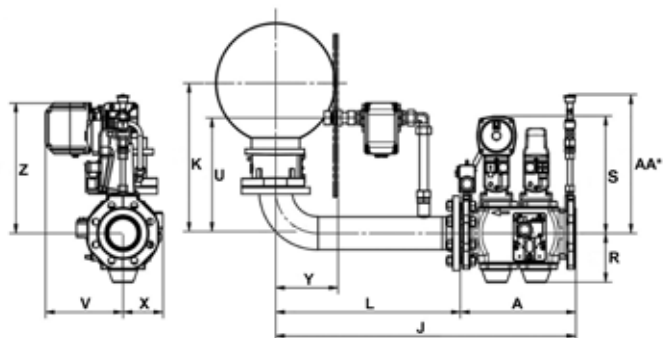

SIEMENS basic gas trains delivery scope and description:

- gas compact unit VGD20/40 including actuators SKP15 and SKP25
- minimum gas pressure switch
- fittings between burner and gas train

i Configuration with gas inlet from the right side (left side on request)

SIEMENS gas trains		
Designation	Type	Code
GT-s706-1"1/2	Threaded design	3759285
GT-s705-2"	Basic version	3759284
GT-s701-65	Flanged design Basic version	3759280
GT-s702-80		3759281
GT-s703-100		3759282
GT-s704-125		3759283

Dimensions	V	X	Z	K	U	J	L	A	Y	R	S	AA ⁽²⁾
GT-s706-1"1/2	210	63	351	404	311	791	500	317	169	96	279	319
GT-s705-2"	210	63	355	434	341	803	500	325	169	103	279	321
GT-s701-65	210	106	329	382	289	792	500	290	169	118	303	363
GT-s702-80	210	108	348	402	309	812	500	310	169	132	313	371
GT-s703-100	210	124	348	402	309	854	502	350	169	145	331	381
GT-s704-125	210	138	348	402	309	904	502	400	169	175	349	396

⁽²⁾: in PED configuration

i Gas trains are fully mounted, electrical connected and tested (electrical, hydraulic, leakage)
Additional components (filter and other options) in order to comply to the local regulation and codes of practise must be ordered separately

FILTERS

Gas filter with flange PN 16, with non-ferrous metal, max. working pressure 2 bar

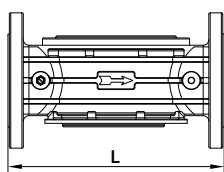

DN40	L = 160 mm	3757196
DN50	L = 160 mm	3757197
DN65	L = 290 mm	3757198
DN80	L = 310 mm	3757201
DN100	L = 350 mm	3757195
DN125	L = 480 mm	3757209
DN150	L = 480 mm	3757210

DUNGS

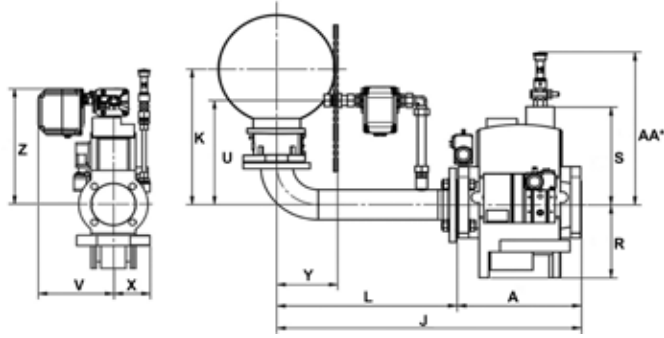

DUNGS basic gas trains delivery scope and description:

- gas compact unit MBC
- minimum gas pressure switch
- fittings between burner and gas train

i Configuration with gas inlet from the right side (left side on request)

DUNGS gas trains		
Designation	Type	Code
GT-d901-65	Flanged design Basic version	3759630
GT-d902-80		3759631
GT-d903-100		3759632

Dimensions	V	X	Z	K		U		J	L	A	Y	R	S	AA ⁽²⁾
				EK/N 8	EK/N 9	EK/N 8	EK/N 9							
GT-d901-65	210	98	447	514	539	406	388	893	600	291	237	183	246	384
GT-d902-80	210	108	447	514	539	406	388	912	600	310	237	205	292	272
GT-d903-100	210	125	447	514	539	406	388	954	600	352	237	250	329	275

⁽¹⁾: model with integrated filter

⁽²⁾: in PED configuration

SIEMENS

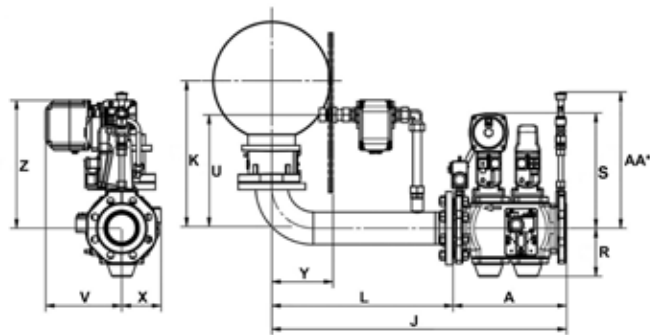

SIEMENS basic gas trains delivery scope and description:

- gas compact unit VGD20/40 including actuators SKP15 and SKP25
- minimum gas pressure switch
- fittings between burner and gas train

i Configuration with gas inlet from the right side (left side on request)

SIEMENS gas trains		
Designation	Type	Code
GT-s901-65	Flanged design Basic version	3759286
GT-s902-80		3759287
GT-s903-100		3759288
GT-s904-125		3759289

Dimensions	V	X	Z	K		U		J	L	A	Y	R	S	AA ⁽²⁾
				EK/N 8	EK/N 9	EK/N 8	EK/N 9							
GT-s901-65	210	106	447	514	539	406	388	892	600	290	237	118	303	363
GT-s902-80	210	108	447	514	539	406	388	912	600	310	237	132	313	371
GT-s903-100	210	124	447	514	539	406	388	952	600	350	237	145	331	381
GT-s904-125	210	138	447	514	539	406	388	1002	600	400	237	175	349	396

⁽²⁾: in PED configuration

i Gas trains are fully mounted, electrical connected and tested (electrical, hydraulic, leakage)
Additional components (filter and other options) in order to comply to the local regulation and codes of practise must be ordered separately

FILTERS

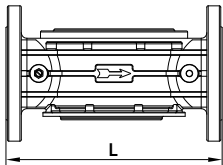
Gas filter with flange PN 16, with non-ferrous metal, max. working pressure 2 bar		DN40	L = 160 mm	3757196
		DN50	L = 160 mm	3757197
		DN65	L = 290 mm	3757198
		DN80	L = 310 mm	3757201
		DN100	L = 350 mm	3757195
		DN125	L = 480 mm	3757209
		DN150	L = 480 mm	3757210

DUNGS

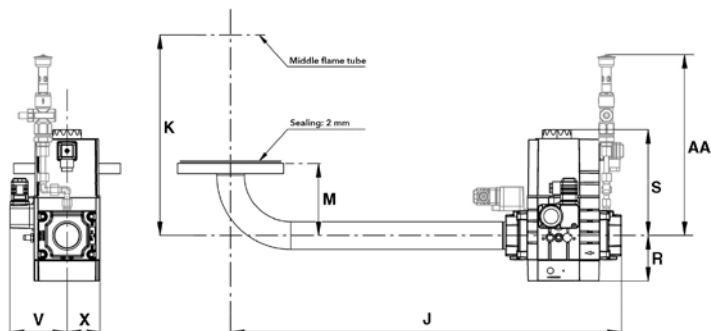

- DUNGS basic gas trains delivery scope and description:**
- gas compact unit MBC
 - minimum gas pressure switch
 - fittings between burner and gas train

i Configuration with gas inlet from the right side (left side on request)

DUNGS gas trains		
Designation	Type	Code
GT-d452-1"1/2 ⁽¹⁾	Threaded design	3750510
GT-d453-2" ⁽¹⁾	Basic version	3750511
GT-d454-65	Flanged design Basic version	3750512
GT-d455-80		3750513
GT-d456-100		3750514

Dimensions	V	X	K		M	J	R	S	AA ⁽²⁾
			EK/N 6	EK/N 7					
d1"1/2-Rp1"1/2	99	57	373	404	126	683	80	186	358
d2"-Rp2"	123	81	403	434	156	757	96	328	384
d65-DN65	106	98	351	382	104	793	183	246	357
d80-DN80	113	108	371	402	124	812	205	292	380
d100-DN100	125	125	371	402	124	854	250	329	398

⁽¹⁾: model with integrated filter

⁽²⁾: in PED configuration

SIEMENS

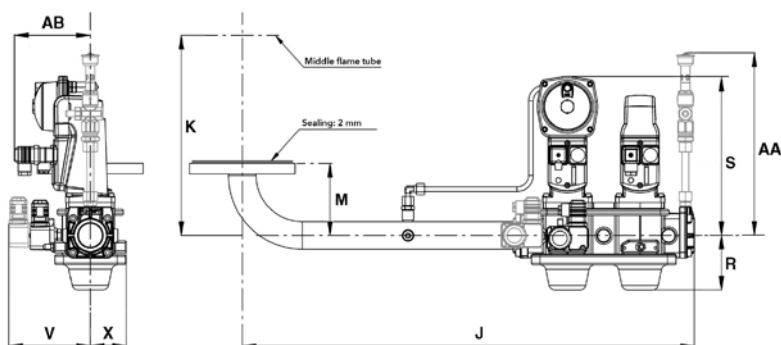

- SIEMENS basic gas trains delivery scope and description:**
- gas compact unit VGD20/40 including actuators SKP15 and SKP25
 - minimum gas pressure switch
 - fittings between burner and gas train

i Configuration with gas inlet from the right side (left side on request)

SIEMENS gas trains		
Designation	Type	Code
GT-s451-1"1/2	Threaded design	3750525
GT-s452-2"	Basic version	3750526
GT-s453-65	Flanged design Basic version	3750527
GT-s454-80		3750528
GT-s455-100		3750529
GT-s456-125		3750530

Dimensions	V	X	AB	K		M	J	R	S	AA ⁽²⁾
				EK/N 6	EK/N 7					
s1"1/2-Rp1"1/2	105	68	125	373	404	126	800	103	279	320
s2"-Rp2"	105	68	125	403	434	156	800	103	279	325
s65-DN65	123	106	125	351	382	104	792	118	304	363
s80-dN80	125	108	125	371	402	124	812	132	314	371
s100-DN100	141	124	125	371	402	124	852	145	332	381
s125-DN125	155	138	125	371	402	124	902	175	350	396

⁽²⁾: in PED configuration

i Gas trains are fully mounted, electrical connected and tested (electrical, hydraulic, leakage)
Additional components (filter and other options) in order to comply to the local regulation and codes of practise must be ordered separately

FILTERS

Gas filter with flange PN 16, with non-ferrous metal, max. working pressure 2 bar

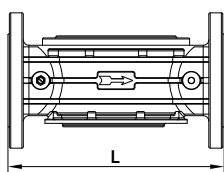

DN40	L = 160 mm	3757196
DN50	L = 160 mm	3757197
DN65	L = 290 mm	3757198
DN80	L = 310 mm	3757201
DN100	L = 350 mm	3757195
DN125	L = 480 mm	3757209
DN150	L = 480 mm	3757210

DUNGS

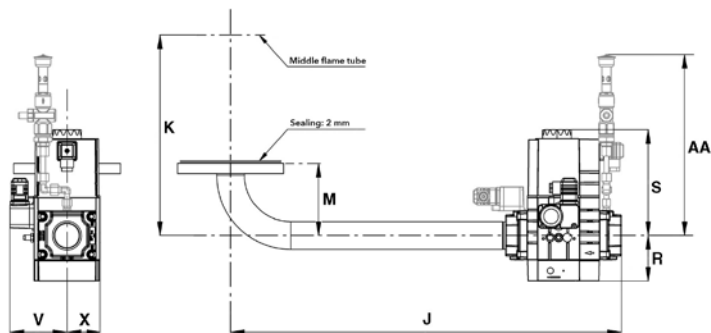

- DUNGS basic gas trains delivery scope and description:**
- gas compact unit MBC
 - minimum gas pressure switch
 - fittings between burner and gas train

i Configuration with gas inlet from the right side (left side on request)

DUNGS gas trains		
Designation	Type	Code
GT-d457-2" ⁽¹⁾	Threaded design	3750515
GT-d458-65	Flanged design Basic version	3750516
GT-d459-80		3750517
GT-d460-100		3750518

Dimensions	V	X	K				M	J	R	S	AA ⁽²⁾
			EK 8	EK 9	N8	N9					
d2"-Rp2"	123	81	514	539	598	623	205	657	96	328	384
d65-DN65	106	98	514	539	598	623	205	693	183	246	357
d80-DN80	113	108	514	539	598	623	205	712	205	292	380
d100-DN100	125	125	514	539	598	623	205	754	250	329	398

⁽¹⁾: model with integrated filter
⁽²⁾: in PED configuration

SIEMENS

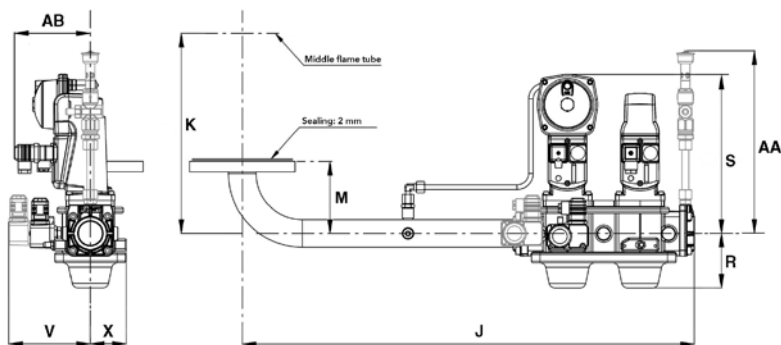

- SIEMENS basic gas trains delivery scope and description:**
- gas compact unit VGD20/40 including actuators SKP15 and SKP25
 - minimum gas pressure switch
 - fittings between burner and gas train

i Configuration with gas inlet from the right side (left side on request)

SIEMENS gas trains		
Designation	Type	Code
GT-s457-2"	Threaded design	3750537
GT-s458-65	Flanged design Basic version	3750538
GT-s459-80		3750539
GT-s460-100		3750540
GT-s461-125		3750541

Dimensions	V	X	AB	K				M	J	R	S	AA ⁽²⁾
				EK 8	EK 9	N8	N9					
s2"-Rp2"	105	68	125	514	539	598	623	205	701	103	279	325
s65-DN65	123	106	125	514	539	598	623	205	692	118	304	363
s80-dN80	125	108	125	514	539	598	623	205	712	132	314	371
s100-DN100	141	124	125	514	539	598	623	205	750	145	332	381
s125-DN125	155	138	125	514	539	598	623	205	800	175	350	396

⁽²⁾: in PED configuration

i Gas trains are fully mounted, electrical connected and tested (electrical, hydraulic, leakage)
 Additional components (filter and other options) in order to comply to the local regulation and codes of practise must be ordered separately

FILTERS

Gas filter with flange PN 16, with non-ferrous metal, max. working pressure 2 bar		DN	L =	Code
		DN40	160 mm	3757196
		DN50	160 mm	3757197
		DN65	290 mm	3757198
		DN80	310 mm	3757201
		DN100	350 mm	3757195
		DN125	480 mm	3757209
		DN150	480 mm	3757210

SIEMENS

SIEMENS basic gas trains delivery scope and description:

- gas compact unit VGD40 including actuators SKP15 and SKP25
- minimum gas pressure switches
- fittings between burner and gas train

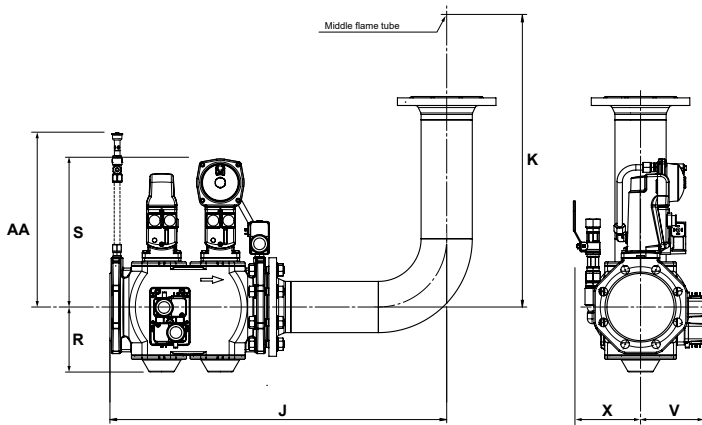

i Configuration with gas inlet from the left side

SIEMENS gas trains		
Designation	Type	Code
s DN80-DN100	Basic configuration valve + connection pipe	3757950
s DN100-DN100		3758623
s DN125-DN100		3760344
s DN150-DN100		3761042

Dimensions	J	K	R	S	V	X	AA ⁽¹⁾
s80	710	912	132	312	125	108	372
s100	750	912	145	335	141	124	356
s125	800	912	175	348	155	138	392
s150	880	912	188	365	176	159	409

⁽¹⁾: in PED configuration

i Configuration with gas inlet from the right side

SIEMENS gas trains		
Designation	Type	Code
s DN80-DN100	Basic configuration valve + connection pipe	3758624
s DN100-DN100		3757952
s DN125-DN100		3761040
s DN150-DN100		3761041

Dimensions	J	K	R	S	V	X	AA ⁽¹⁾
s80	710	912	132	312	125	108	372
s100	750	912	145	335	141	124	356
s125	800	912	175	348	155	138	392
s150	880	912	188	365	176	159	409

⁽¹⁾: in PED configuration

i Gas trains are fully mounted, electrical connected and tested (electrical, hydraulic, leakage)
Additional components (filter and other options) in order to comply to the local regulation and codes of practise must be ordered separately

FILTERS

Gas filter with flange PN 16, with non-ferrous metal, max. working pressure 2 bar	DN80	L = 310 mm	3757201
	DN100	L = 350 mm	3757195
	DN125	L = 480 mm	3757209
	DN150	L = 480 mm	3757210

SIEMENS

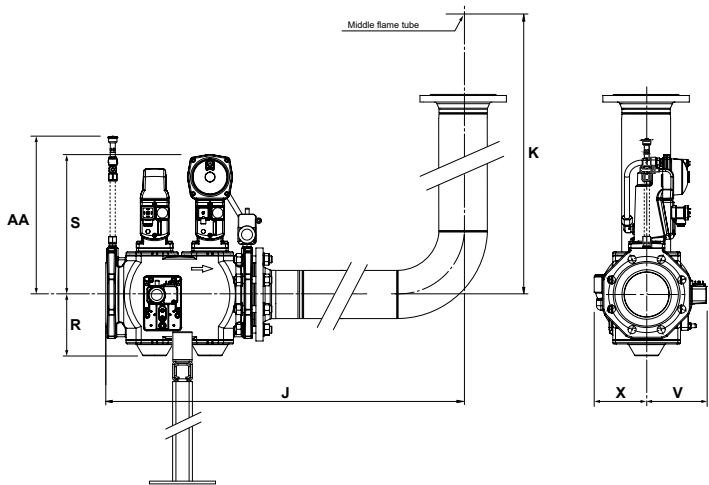

SIEMENS basic gas trains description:

- gas compact unit VGD40 including actuators SKP15 and SKP25
- minimum gas pressure switches
- fittings between burner and gas train
- an additional support for the gas train is required (code 3752216, see page 326)

i Configuration with gas inlet from the left side

SIEMENS gas trains		
Designation	Type	Code
s100	Basic configuration valve + connection pipe	3761110
s125		3761111
s150		3761112

⁽¹⁾: in PED configuration

Dimensions	J	K	R	S	V	X	AA ⁽¹⁾
s100	1275	788	145	332	141	124	356
s125	1275	788	175	349	155	138	392
s150	1275	788	188	366	176	159	409

i Configuration with gas inlet from the right side

SIEMENS gas trains		
Designation	Type	Code
s100	Basic configuration valve + connection pipe	3761107
s125		3761108
s150		3761109

⁽¹⁾: in PED configuration

Dimensions	J	K	R	S	V	X	AA ⁽¹⁾
s100	1275	788	145	332	141	124	356
s125	1275	788	175	349	155	138	392
s150	1275	788	188	366	176	159	409

i Gas trains are fully mounted, electrical connected and tested (electrical, hydraulic, leakage)
Additional components (filter and other options) in order to comply to the local regulation and codes of practise must be ordered separately

FILTERS

Gas filter with flange PN 16, with non-ferrous metal, max. working pressure 2 bar	DN80	L = 310 mm	3757201
	DN100	L = 350 mm	3757195
	DN125	L = 480 mm	3757209
	DN150	L = 480 mm	3757210

SIEMENS

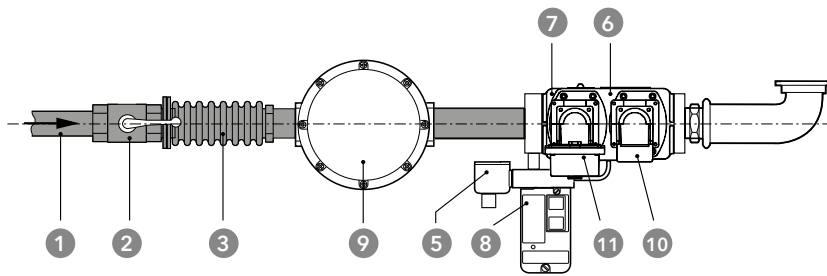

- 1. main gas pipe
- 2. ball valve*
- 3. anti-vibration coupling*
- 5. minimum gas pressure switch
- 6. safety gas valve
- 7. main gas valve
- 8. leakage control device*
- 9. gas filter* (governor included in the valve)
- 10. actuator SKP 15
- 11. actuator SKP 25

*: additional components to be ordered separately, e.g.: maximum gas pressure switch and other gas options in order to comply to the local regulation and codes of practise

Designation	Description	Code
GT-2"	VGD20.503	on request
GT-DN65	VGD40.065	on request
GT-DN80	VGD40.080	on request
GT-DN100	VGD40.100	on request
GT-DN125	VGD40.125	on request

GHO-TRON configuration:
gas ignition unit is included in the body of the burner, the price is included in the burner price.

i Gas trains are fully mounted, electrical connected and tested (electrical, hydraulic, leakage)
Additional components (filter and other options) in order to comply to the local regulation and codes of practise must be ordered separately

FILTERS

2"	on request
DN65 - 2"1/2	on request
DN80 - 3"	on request
DN100 - 4"	on request
DN125 - 5"	on request

GAS TRAIN CONNECTION PIPE

GTCP RP50 platform 2-3-4	GHO-TRON 2-3-4 with GT-2"	on request
GTCP reducer from DN80 to DN65 platform 2-3-4	GHO-TRON 2-3-4 with GT-DN65	on request
GTCP reducer from DN100 to DN80 platform 4-5	GHO-TRON 4-5 with GT-DN100	on request
GTCP reducer from DN125 to DN80 platform 5	GHO-TRON 5 with GT-DN125	on request

CONTROL UNITS BT320, BT330, BT340

The device is composed of a control box for safety and for programming the parameters of mono- and dual fuel burners with intermittent or continuous operation through a step by step servomotor up to 10 Nm.

The BT300 combines the benefits of an electronic fuel-air ratio control system with up to three motorised actuating devices and an optional modules like an analogue output for speed control of the combustion air fan with an electronic burner control unit.

The device is equippable with the following modules:

- fan speed regulation;
- burner power regulation;
- control of combustion air excess;
- CO control (through simple or combined probe);
- communication via Bus system.

The BT300 is available in three designs with the following specific functions:

- **BT320** for single fuel burner and intermittent operation, with an output 0...10 V, 0/4...20 mA and the management of two servomotors;
- **BT330** for single fuel burner and continuous operation, using suitable flame detectors, with an output 0...10 V, 0/4...20 mA and the management of three servomotors;
- **BT340** for dual fuel burner and continuous operation, using suitable flame detectors, with an output 0...10 V, 0/4...20 mA and the management of three servomotors.

Main characteristics of the control box:

- power supply: 230 V -15...+10%, 50 Hz;
- servomotors from 1,2 to 10 Nm.

COMMUNICATION MODULE

BT300 module for electronic burners mounted in the switch cabinet of the burner (Note: one LCM module is required)	ModBus/BT3	3754081
	ProfiBus/BT3	3750142
	Ethernet/BT3	on request

LCM MODULE

Module required for O ₂ control, Variatron and communication buses connections	3752286
---	----------------

Note: only one LCM module is necessary for these 3 options; the module is already included on dual fuel burners

REMOTE SOFTWARE

Kit to connect a PC laptop to the BT300 for its parametrization	LSA100 + USB/CAN + CD-Rom	3751130
---	---------------------------	----------------

CONTROL UNITS ETAMATIC AND ETAMATIC OEM

The Etamatic control units are available on request according to the configuration of the burner selected.

Electronic control **Etamatic** with 4 DPS-adjusting outputs for servodrives up to 50 mA of direct current with:

- incorporated tightness control of the valves;
- incorporated regulator of power;
- incorporated counter of working hours with pulse transducer;
- incorporated relay of flame;
- incorporated program of O₂ regulation, including the Lamtec system with connecting bus.

Electronic control **Etamatic S** with a steady adjusting output for the regulation of the number of revolutions of the fan supplying the air of burning and 4 DPS-adjusting outputs for the servodrives up to 50 mA of direct current with:

- incorporated tightness control of the valves;
- incorporated regulator of power;
- incorporated counter of working hours with pulse transducer;
- incorporated relay of flame;
- incorporated program of O₂ regulation, including the Lamtec system with connecting bus.

For the control of the number of revolutions it is required additionally:

- Static frequency converter;
- Switch Namur.

INTERFACE MODULES FOR ETAMATIC AND ETAMATIC OEM

Profibus module for ETA+OEM with 2 m cable	3752995
Modbus module RTU RS232 for ETA+OEM with 2m cable	3752467
Modbus module RTU RS422/484 for ETA+OEM with 2m cable	3756474
Ethernet module TCP/IP for ETA+OEM with 2m cable	3757955

ACCESSORIES FOR ETAMATIC OEM

Software for remote PC connection for Lamtec ETAMATIC OEM with all its accessories for the connection (available languages: English, German and French)	3753366
Customer interface (DISPLAY) for ETAMATIC OEM	3751683
Hand held programming unit for ETAMATIC OEM (languages: German and English) – Alternative to software 3753366 when PC is not available	1718850339
Hand held programming unit for ETAMATIC OEM (language: Russian) – Alternative to software 3753366 when PC is not available	3754519

Note: either customer interface or operation and display unit has to be included

O₂ TRIM FOR BT300, ETAMATIC AND ETAMATIC OEM, FMS/VMS

This kit is used to optimize the combustion in order to keep the air excess as much stable as possible irrespective of the changes that can occur during operations, for instance slight calorific value variations, combustion air temperature and pressure. This improves the seasonal efficiency and therefore reduces the fuel consumption.

The kit includes the following components:

- Lambda transmitter LT3
- Lambda probe LS2
- Probe installation fitting (PIF)
- Gas extraction device (GED)

The control unit has to be installed close to the probe (max 10 m of cable).
 The probe needs a calibration but no reference gas is necessary.
 The display shows the O₂ content.
 Maximum distance between the LT3 and the burner control panel is 500 m.

	Additional LSB modules installed at LT3	GED length	Code
Kit for O₂ trim (LT3 + LS2) Flue temp max 300 °C - Display for O₂ visualization (Note: for models equipped with BT3 this kit needs a LCM module installed in the burner control panel)	none	150 mm	3759296
		300 mm	3759297
		450 mm	3759298
	4x 0/4-20 mA output	150 mm	3759299
		300 mm	3759300
		450 mm	3759301
	4x 0/4-20 mA output + 4x digital output	150 mm	3759302
		300 mm	3759303
		450 mm	3759304

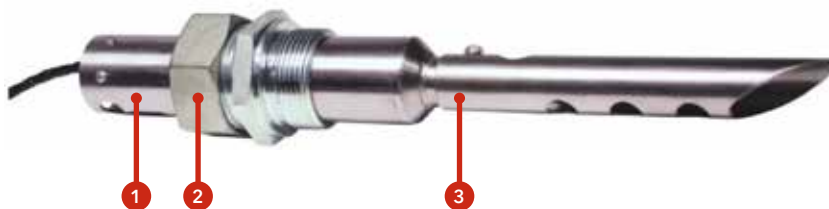

1. Lambda Probe LS2 in standard housing up to 300°C (572°F); default cable length is 2 m (6.5 ft), FEP, with connecting plug
2. Probe installation fitting (PIF)
3. Gas extraction device (GED)

The LS2 lambda probe is equipped with a 2 meter long connection cable that connects the sensor to the transmitter (LT3). It is possible to extend the connection up to a maximum distance of 10 meters (for greater lengths the conformity expires) with a ready-made cable and a probe connection box (PCB).

Description		Code
Extension for LS2	5m ready-made cable	3759318
	PCB (probe connection box)*	3759319

The PCB is a small terminal box that is connected to the 2 meter long cable already existing on the probe. The wiring between the PCB and the transmitter must be carried out on the construction site with suitable cables and trained personnel.

*: the PCB is mandatory if the end user chooses to use his own connecting cable and not one of those proposed (max total length remains 10m)

O₂/CO_e TRIM FOR BT300, ETAMATIC AND ETAMATIC OEM, FMS/VMS

This kit is used for optimizing the combustion in order to keep the air excess as low as possible in order to maximize the seasonal efficiency and therefore minimize the fuel consumption. In addition to the features of the O₂ trim only, this kit reduces the air excess to its minimum because this system continuously measures the content of unburned fuel (CO_e) in the flue: should the air excess be reduced too much, the CO_e raises and the system reacts by increasing the air excess in order to keep firing in safe conditions.

The kit includes the following components:

- Lambda transmitter LT3-F
- Lambda probe KS1D
- Probe installation fitting (PIF)
- Gas extraction device (GED)

The control unit has to be installed close to the probe (max 10 m of cable). The probe needs a calibration but no reference gas is necessary. The display shows the O₂ and CO_e content. Maximum distance between the LT3-F and the burner control panel is 500 m.

Note: this system is not suitable for GL-EUF and L-EUF burners

	Additional LSB modules installed at LT3-F	GED length	Code
Kit for O₂ trim and CO control (LT3-F + KS1D) Flue temp max 300 °C (Note: for models equipped with BT3 this kit needs a LCM module installed in the burner control panel)	none	150 mm	3759305
		300 mm	3759306
		450 mm	3759307
	4x 0/4-20 mA output	150 mm	3759308
		300 mm	3759309
		450 mm	3759310
	4x 0/4-20 mA output + 4x digital output	150 mm	3759311
		300 mm	3759312
		450 mm	3759313

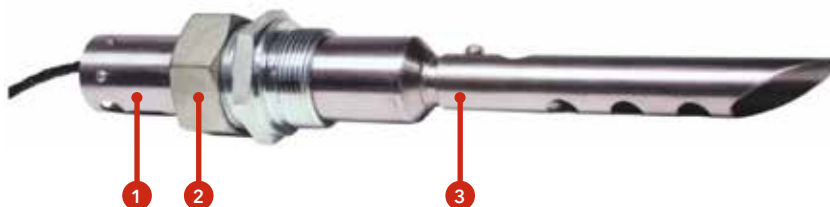

1. Lambda Probe KS1D in standard housing up to 300°C (572°F); default cable length is 2 m (6.5 ft), FEP, with connecting plug
2. Probe installation fitting (PIF)
3. Gas extraction device (GED)

The KS1D lambda probe is equipped with a 2 meter long connection cable that connects the sensor to the transmitter (LT3-F). It is possible to extend the connection up to a maximum distance of 10 meters (for greater lengths the conformity expires) with a ready-made cable and a probe connection box (PCB).

Description	Code	
Extension for KS1D	5m ready-made cable	3759318
	PCB (probe connection box)*	3759319

The PCB is a small terminal box that is connected to the 2 meter long cable already existing on the probe. The wiring between the PCB and the transmitter must be carried out on the construction site with suitable cables and trained personnel.

*: the PCB is mandatory if the end user chooses to use his own connecting cable and not one of those proposed (max total length remains 10m)

SPARE PARTS FOR O₂ AND O₂/CO TRIM

Lambda transmitter LT3	Additional LSB modules installed:	none	4396180*
		4x 0/4-20 mA output	65314636
		4x 0/4-20 mA output + 4x digital output	65314637
Lambda transmitter LT3-F	Additional LSB modules installed:	none	65314641
		4x 0/4-20 mA output	65314638
		4x 0/4-20 mA output + 4x digital output	65314639
LSB modules	4x 0/4-20 mA output		65314642
	4x digital output		65314643
Lambda probes	Lambda probe LS2		4396179*
	Lambda probe KS1D		65314645
Probe installation fitting (PIF)			65314646
Gas extraction device (GED)	GED length 150mm		65314647
	GED length 300mm		65314648
	GED length 450mm		65314649
Wiring adapters*	Adapter 655R1027, to adapt a new LS2 with 5-pin round plug to an old LT2/LT3 version with automotive plug		6500790800
	Adapter 655R1028, to adapt an old LS2 version with automotive plug to a new LT3 version with 5-pin round plug		6500791100

i *: As of July 2024, the LS2 probe is shipped with a new 5-pin plug, replacing the previous configuration with dual auto plugs. Consequently, the LT3 transmitter has a new plug socket.

For **new installations** refer to the codes with the new configuration at page 317.

In case of an **existing system**:

- to connect a new LS2 probe (code 4396179) to an existing probe connection box, it is necessary to add the adapter 655R1027 (code 6500790800);



- in order to connect the old LS2 probe to a new LT3 transmitter (code 4396180), it is necessary to add the adapter 655R1028 (code 6500791100)



FREQUENCY CONVERTER ABB FOR EXTERNAL INSTALLATION

IP21 with: <ul style="list-style-type: none"> • EMC filter • Inductor • Control panel 	3 kW	3757054
	4 kW	3757055
	5,5 kW	3757056
	7,5 kW	3757057
	11 kW	3757058
	15 kW	3757059
	18,5 kW	3757060
	22 kW	3757061
	30 kW	3757062
	37 kW	3757063
	45 kW	3757064
	55 kW	3757065
	75 kW	3757066
IP55 with: <ul style="list-style-type: none"> • EMC filter • Inductor • Control panel 	3 kW	3757067
	4 kW	3757068
	5,5 kW	3757069
	7,5 kW	3757070
	11 kW	3757071
	15 kW	3757072
	18,5 kW	3757073
	22 kW	3757074
	30 kW	3757075
	37 kW	3757076
	45 kW	4396082
	55 kW	3757078
	75 kW	3757079

ACOUSTIC SHROUDS FOR EK EVO AND N10

Product description:

- sound level reduction (sound pressure level): ca. 20 ... 30 dB(A)
- sheet metal casing, structured coating, isolation with temperature resistant mineral wool
- noise absorption material acc. DIN 4102, covered with a glass fibre layer, covered with perforated sheet metal, galvanised
- easily disassembled into elements: base plate, side covers, top cover, air inlet section
- all elements easily connected via quick locks
- height of noise reduction casing adjustable on wheels
- feed through for gas-, oil- and electrical connections integrated in side covers following the requirements
- air inlet via noise reduction line
- if required, an oil recuperation tub can be integrated on the base plate
- for some boiler types a supporting frame for the casing may be necessary, due to the height of the burner tube over the floor

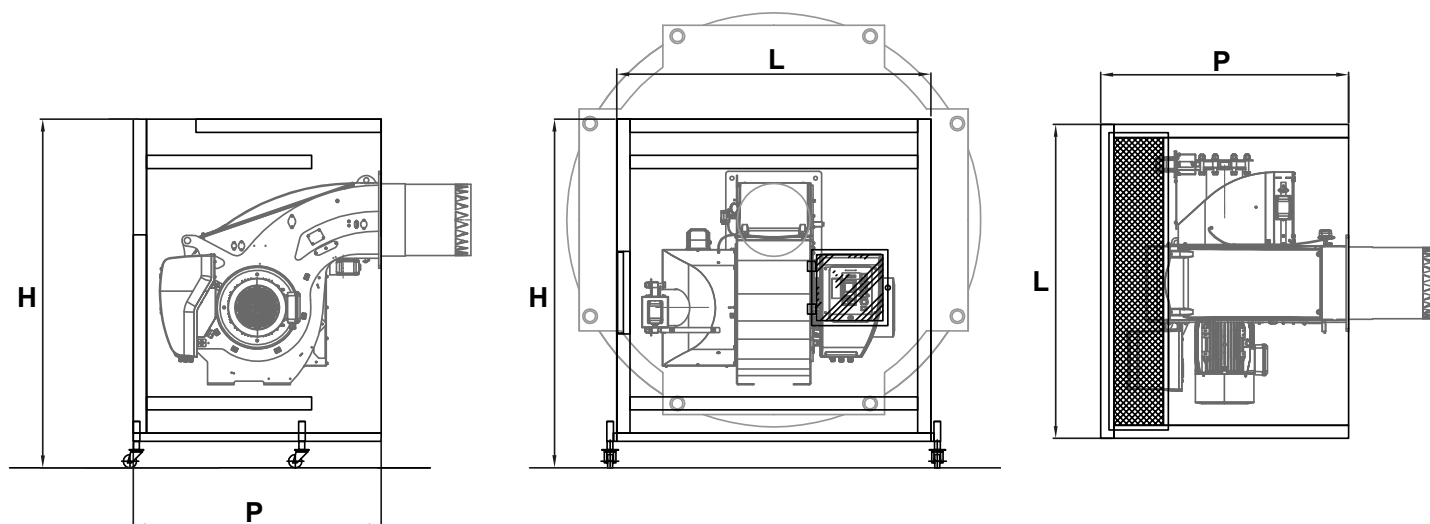

! Drawings and dimensions are shown for informational purposes and may vary depending on technical requirements.

MODELS FOR EK EVO

Designation	L (mm)	P (mm)	H (mm)	Weight (kg)	Code
EKEVO 6.2400/2900 G-...	1450	1350	1200	200	on request
EKEVO 7.3600/4500 G-...	1550	1400	1300	246	on request
EKEVO 7.5800/7700 G-...	1570	1850	1300	246	on request
EKEVO 8.5800/7100 G-...	1760	1630	1580	325	on request
EKEVO 9.8700/10400 G-...	1750	1630	1750	368	on request
EKEVO 9.13000 G-...	1850	1750	1750	396	on request
EKEVO 6.2400/2900 GL-.../L-...	1450	1350	1200	200	on request
EKEVO 7.3600/4500 GL-.../L-...	1550	1400	1300	246	on request
EKEVO 8.5800/7100 GL-.../L-...	1760	1630	1580	335	on request
EKEVO 9.6500...10400 GL-.../L-...	1760	1630	1750	378	on request

MODELS FOR N10

Designation	L (mm)	P (mm)	H (mm)	Weight (kg)	Code
N10 G-...	1900	1780	1900	478	on request
N10 GL-...	1900	1780	1900	488	on request
N10 L-...	1900	1780	1900	488	on request

NOTE: Before submitting your order please provide information on the boiler model and the type of installation: floor standing boiler or boiler mounted on a base.

BALL VALVE

	Female threaded ball valve, max. working gas pressure: 1 bar	FRp1/2"	3751028
		FRp3/4"	3751029
		FRp1"	3751030
		FRp1"1/2	3751031
	Flanged ball valve, max. working gas pressure: 16 bar	FRp2"	3751032
		DN40	3751033
		DN50	3751034
		DN65	3751035
		DN80	3751036
		DN100	3751037
		DN125r	3751038
		DN150	3751039

ANTI-VIBRATION COUPLING (COMPENSATOR)

	Male-threaded anti-vibration coupling	MRp1"	3751018
		MRp1"1/2	3751019
		MRp2"	3751020
	Flanged anti-vibration coupling, max. working gas pressure: 10 bar	DN40	3751021
		DN50	3751022
		DN65	3751023
		DN80	3751024
		DN100	3751025
		DN125	3751026
		DN150	3751027

GAS FILTER

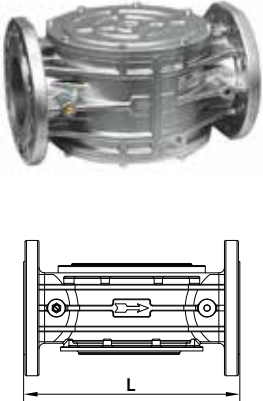
	Filter with non-ferrous metal, max. working pressure: 2 bar	Rp1"1/2	L = 160 mm	3757199
		Rp2"	L = 160 mm	3757200
	Filter with flange PN16, non-ferrous metal, max. working pressure: 2 bar	DN40	L = 230 mm	3757196
		DN50	L = 230 mm	3757197
		DN65	L = 290 mm	3757198
		DN80	L = 310 mm	3757201
		DN100	L = 350 mm	3757195
		DN125	L = 480 mm	3757209
		DN150	L = 480 mm	3757210
	Filter with flange PN16, non-ferrous metal, max. working pressure: 6 bar	DN40	L = 230 mm	3757205
		DN50	L = 230 mm	3757206
		DN65	L = 290 mm	3757207
		DN80	L = 310 mm	3757208
		DN100	L = 350 mm	3757202
		DN125	L = 480 mm	3757203
		DN150	L = 480 mm	3757204

PRESSURE REGULATOR

<p>Gas pressure regulator GDJ Max. working pressure 0,4 bar, non-ferrous metal</p> 	GDJ Rp1/2" x 100 mm	with spring 16 ... 28 mbar	3333123399
		spring for 10 ... 20 mbar	1478682742
		spring for 22 ... 40 mbar	1478781122
		spring for 40 ... 55 mbar	12001218
	GDJ Rp3/4" x 125 mm	with spring 12,5 ... 25 mbar	3333123400
		spring for 22,5 ... 35 mbar	3753834
		spring for 30 ... 50 mbar	3753835
	GDJ Rp1" x 125 mm	with spring 12,5 ... 25 mbar	3333123401
		spring for 22,5 ... 35 mbar	3753834
		spring for 30 ... 50 mbar	3753835
	GDJ Rp1"1/2 x 155 mm	with spring 12,5 ... 25 mbar	3333123402
		spring for 22,5 ... 35 mbar	3753840
		spring for 30 ... 50 mbar	3753841
	GDJ Rp2" x 200 mm	with spring 12,5 ... 25 mbar	3333123403
		spring for 22,5 ... 35 mbar	3753847
		spring for 30 ... 50 mbar	3753848
<p>Gas pressure regulator FRS Max. working pressure 0,4 bar, non-ferrous metal</p> 	FRS s40-DN40 x 200 mm	with spring 10 ... 30 mbar	1478490702
		red spring for 25 ... 55 mbar	1478435327
		yellow spring for 30 ... 70 mbar	1478435338
		black spring for 60 ... 110 mbar	1478435349
	FRS s50-DN50 x 230 mm	with spring 10 ... 30 mbar	1478490713
		red spring for 25 ... 55 mbar	1478435372
		yellow spring for 30 ... 70 mbar	1478435383
		black spring for 60 ... 110 mbar	1478435394
	FRS s65-DN65 x 290 mm	with spring 10 ... 30 mbar	1478490724
		red spring for 25 ... 55 mbar	1478435429
		yellow spring for 30 ... 70 mbar	1478435430
		black spring for 60 ... 110 mbar	1478435441
		pink spring for 100 ... 150 mbar	1478494328
	FRS s80-DN80 x 310 mm	with spring 10 ... 30 mbar	3750211
		red spring for 25 ... 55 mbar	1478435429
		yellow spring for 30 ... 70 mbar	1478435430
		black spring for 60 ... 110 mbar	1478435441
		pink spring for 100 ... 150 mbar	1478494328
	FRS s100-DN100 x 350 mm	with spring 10 ... 30 mbar	12001097
		red spring for 25 ... 55 mbar	1478435474
		yellow spring for 30 ... 70 mbar	1478435485
		black spring for 60 ... 110 mbar	1478435496
		pink spring for 100 ... 150 mbar	1478781519
	FRS s125-DN125 x 400 mm	with spring 10 ... 30 mbar	12001098
		red spring for 25 ... 55 mbar	1478434982
		yellow spring for 30 ... 70 mbar	1478434993
		black spring for 60 ... 110 mbar	1478435009
		pink spring for 100 ... 150 mbar	1478740474
FRS s150-DN150 x 480 mm	with spring 10 ... 30 mbar	12001099	
	red spring for 25 ... 55 mbar	1478435032	
	yellow spring for 30 ... 70 mbar	1478435043	
	black spring for 60 ... 110 mbar	1478435054	
	pink spring for 100 ... 150 mbar	1478781484	

PRESSURE REGULATOR

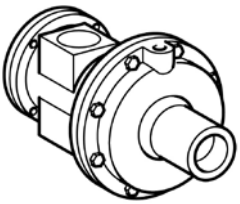
Gas pressure regulator RS 250	with safety valve and flange PN16, max. working pressure 6 bar	RS250 DN25 x 230 mm	1478541586
		RS250 DN50 x 230 mm	1478541597
		RS250 DN80 x 310 mm	1478541600
		RS250 DN100 x 350 mm	1478541611
		RS250 DN150 x 480 mm	1478541622
Gas pressure regulator RS 251	with safety valve and flange PN16, max. working pressure 4 bar	RS251 DN50 x 310 mm	1478548747
		RS251 DN80 x 410 mm	1478548758
Safety blow-off valve S10 	with internal thread Rp1", max. working pressure 1 bar	discharge pressure 80 mbar	1478687054
		discharge pressure 100 mbar	1478687065
		discharge pressure 120 mbar	1478687076
		discharge pressure 140 mbar	1478687087
		discharge pressure 160 mbar	1478687098
		discharge pressure 180 mbar	1478687101
		discharge pressure 200 mbar	1478687112
		discharge pressure 220 mbar	1478687123
		discharge pressure 240 mbar	1478687134
		discharge pressure 260 mbar	1478687145
		discharge pressure 280 mbar	1478687156
		discharge pressure 300 mbar	1478687167

GAS PRESSURE SWITCH

	For installation on double electromagnetic valves, max. working pressure 0,5 bar	GW50A5	3751554
		GW150A5	3751555
		GW500A5	3752190
	For installation on electromagnetic/motorized valves, max. working pressure 0,5 bar	GW50A6	3752189
		GW150A6	3751556
		GW500A6	3751557

MANOMETER

	Gas manometers with push-button valve, Rp1/2"	0 - 60 mbar	3751627
		0 - 100 mbar	3751546
		0 - 160 mbar	3751550
		0 - 250 mbar	3751551
		0 - 600 mbar	3751552
		0 - 1,6 bar	3751545
		0 - 6 bar	3751544

TEST BURNER

Test burner with push-button valve, Rp1/2"	max pressure 0,5 bar	3751553
---	----------------------	----------------

INSERT RING

	Insert ring with connections Rp1/2" and Rp3/4" for manometer and test burner	DN40	L = 50 mm	3752194
		DN50	L = 50 mm	3752195
		DN65	L = 50 mm	3752196
		DN80	L = 50 mm	3752197
		DN100	L = 50 mm	3752198
		DN125	L = 50 mm	3752199
		DN150	L = 50 mm	3752200

GAS FLOW METERS

	TME 400-VM without 4-20mA output	DN50 - PN10	100 m³/h	L = 150 mm	3757525
		DN80 - PN10	400 m³/h	L = 120 mm	3757527
		DN100 - PN10	650 m³/h	L = 150 mm	3757529
		DN150 - PN10	1000 m³/h	L = 175 mm	3757530
		DN150 - PN10	1600 m³/h	L = 175 mm	3757531
	TME 400-VM-A with 4-20mA output	DN50 - PN10	100 m³/h	L = 150 mm	3757534
		DN80 - PN10	400 m³/h	L = 120 mm	3757536
		DN100 - PN10	650 m³/h	L = 150 mm	3757538
		DN150 - PN10	1000 m³/h	L = 175 mm	3757539
		DN150 - PN10	1600 m³/h	L = 175 mm	3757540
	TME 400 reversion kit power module				3759090
	Transmitter power supply KFD2-STC5-1				3758822

FLEXIBLE HOSE

	Stainless steel, max pressure 4 bar	Rp1/2"	L = 500 mm	4488681772
		Rp1/2"	L = 1000 mm	4488681783
		Rp3/4"	L = 500 mm	4488681794
		Rp3/4"	L = 1000 mm	4488682708
		Rp1"	L = 500 mm	4488682719
		Rp1"	L = 1000 mm	4488682720
	Stainless steel, max pressure 1 bar	Rp3/8"-Rp1/2"	L = 500 mm	4488696511
		Rp3/8"-Rp1/2"	L = 1000 mm	4488696522
		d2"-Rp2"	L = 500 mm	4488696533
		d2"-Rp2"	L = 1000 mm	4488696544

HOLDER

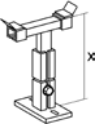
	<p>Holder for gas train</p>	<p>For gas train DN40...DN150 Support height: x = 545...935 mm</p>	<p>3752216</p>
---	-----------------------------	--	----------------

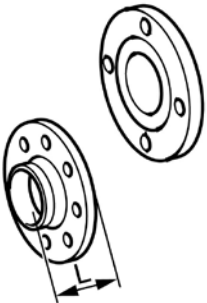

FLANGES

	<p>Threaded flange PN16</p>	<p>Rp3/4" 1" Rp1"1/2 Rp2"</p>	<p>3333109195 3333109196 3333109197 3333109198</p>
	<p>Welded flange PN16</p>	<p>DN40 x 42 mm DN50 x 45 mm DN65 x 45 mm DN80 x 50 mm DN100 x 52 mm DN125 x 55 mm DN150 x 55 mm</p>	<p>5318353048 5318428082 5318428093 5318428106 5318428117 5318428128 5318428139</p>

STRAIGHT PIPE

	<p>Flanged, PN16</p>	<p>DN40 x 500 mm DN50 x 250 mm DN50 x 500 mm DN65 x 250 mm DN65 x 500 mm DN80 x 250 mm DN80 x 500 mm DN100 x 250 mm DN100 x 500 mm DN125 x 250 mm DN125 x 500 mm DN150 x 250 mm DN150 x 500 mm</p>	<p>3752235 3752236 3752237 3752238 3752239 13019834 1688421230 3752240 1688421252 1688421525 1688421274 1688421536 1688421296</p>
	<p>Adapting, flanged PN16</p>	<p>DN25 - DN40 x 144 mm DN25 - DN50 x 159 mm DN25 - DN65 x 173 mm DN25 - DN80 x 254 mm DN40 - DN50 x 163 mm DN40 - DN65 x 177 mm DN40 - DN80 x 182 mm DN50 - DN65 x 180 mm DN50 - DN80 x 185 mm DN50 - DN100 x 197 mm DN65 - DN80 x 197 mm DN65 - DN100 x 197 mm DN80 - DN100 x 202 mm DN80 - DN125 x 232 mm DN80 - DN150 x 245 mm DN100 - DN125 x 234 mm DN100 - DN150 x 247 mm DN125 - DN150 x 250 mm</p>	<p>1688541804 1688586714 1688590469 1688653209 3752223 3752224 3752226 3752225 3752227 1688590458 1688421401 1688421412 1688421423 1688421434 1688602591 1688421445 1688421456 1688421467</p>

ELBOW PIPE

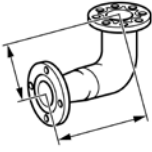
<p>Angle</p> 	90°, male/female	Rp3/4"	3333109257	
		Rp1"	3333103790	
		Rp1"1/4	3333116894	
		Rp1"1/2	3333103791	
		Rp2"	3333103792	
	90°, female/female	Rp1"	3333109311	
		Rp1"1/2	3333110711	
		Rp2"	3333110712	
	<p>Elbow</p> 	PN16, connection Rp1/2"	DN40 x 99 mm	3752182
			DN50 x 121 mm	3752183
DN65 x 140 mm			3752184	
DN80 x 164,5 mm			3752185	
DN100 x 204,5 mm			1688421354	
DN125 x 245,5 mm			1688421365	
DN125 x 283,5 mm			1688421376	
<p>Connection piece</p> 	90°, flanged PN16	DN65 - DN40 x 235 mm	1688551557	
		DN65 - DN50 x 235 mm	1688551568	
		DN80 - DN40 x 246,5 mm	1688421092	
		DN80 - DN50 x 249,5 mm	1688421105	
		DN80 - DN65 x 249,5 mm	1688421116	
		DN80 - DN80 x 264,5 mm	1688421127	
		DN80 - DN100 x 266,5 mm	1688590481	
		DN100 - DN65 x 297,5 mm	3755875	
		DN100 - DN80 x 302,5 mm	1688551615	
		DN150 - DN65 x 503,5 mm	1688666166	
		DN150 - DN80 x 418,5 mm	1688421138	
		DN150 - DN100 x 420,5 mm	1688421149	
		DN150 - DN125 x 423,5 mm	1688421150	
		DN150 - DN150 x 423,5 mm	1688421161	

GAS PIPE

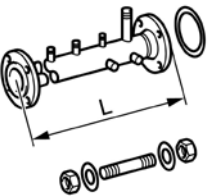
<p>Connections</p>	h3/8"-Rp1/2"x300 mm with two connections 1/2" and one connection 1/4" for DMV SE 512	3333212374	
	d2"-Rp2"x300 mm with two connections 1/2" and one connection 1/4" for DMV SE 520	3333212375	
	Connections for test burner, pressure switch, pressure valve, pressure release valve, ignition valve, safety valve	DN40 x 900 mm	14030405
		DN50 x 900 mm	14030449
		DN65 x 950 mm	code on request
		DN80 x 1100 mm	14030504
		DN100 x 1300 mm	14030537
		DN125 x 1550 mm	code on request
		DN150 x 1800 mm	14030570

SEALS AND CONNECTING KIT

	<p>Screwing set: 1 seal, 4 bolts, 4 nuts, 4 washers</p>	DN25	3751547
		DN40	3751040
		DN50	3756205
		DN65	3756206
		DN80	3756207
		DN100	3756208
		DN125	3756209
		DN150	3756210

UNITS FOR AIR-SEPARATION OF RETURN FUEL, TYPE LBA...A

Units for air-separation of return fuel for single-pipe installation with monoblock burners and systems according to DIN 4755/2 and TRD 411 or TRD 604.

- Fuel: light oil type EL and L (heavy oil M and S on request)
- Supply pressure: 1 to 5 bar
- Internal setting: max 45°C

Other designs (e.g. for suction operation or deviating accessories) may be provided on request.

Basic design A for supply pressure:

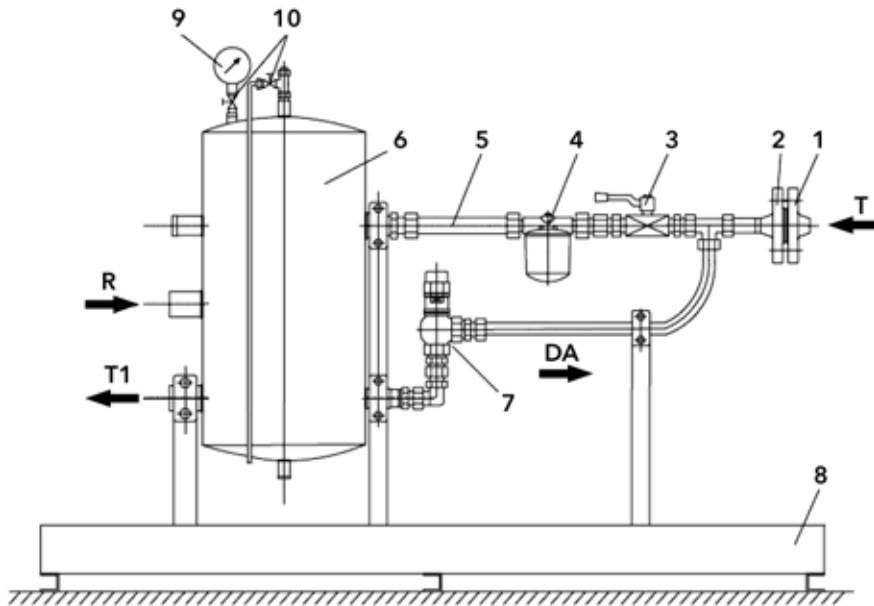

Base equipment

1. Welded flange PN16
2. Connecting flange PN16
3. Ball valve PN16
4. Fuel filter
5. Fuel rate counter with roller counter
6. Pressure tank
7. Relief valve
8. Fuel collector with holding
9. Glycerol manometer 0...10 bar
10. Air valve

		LBA 600 A	LBA 1200 A	LBA 2400 A	LBA 3000 A
Burner pump capacity	[l/h]	600	1200	2400	3000
Fuel rate for burner capacity "T"	[l/h]	10 ... 200	10 ... 400	30 ... 1000	75 ... 2000
Flange connection "T" on feed line	PN16	DN15	DN15	DN20	DN25
Burner connection "R" and "T1" (feed + return pipe)		Rp1/2"	Rp3/4"	Rp1"	Rp1"
Volume pressure tank	[l]	5	18	30	30
Dimension L x B	[mm]	1050 x 360	1400 x 500	1400 x 500	1400 x 500
Code		on request	on request	on request	on request

OPTIONS FOR AIR-SEPARATION UNIT, TYPE LBA...A

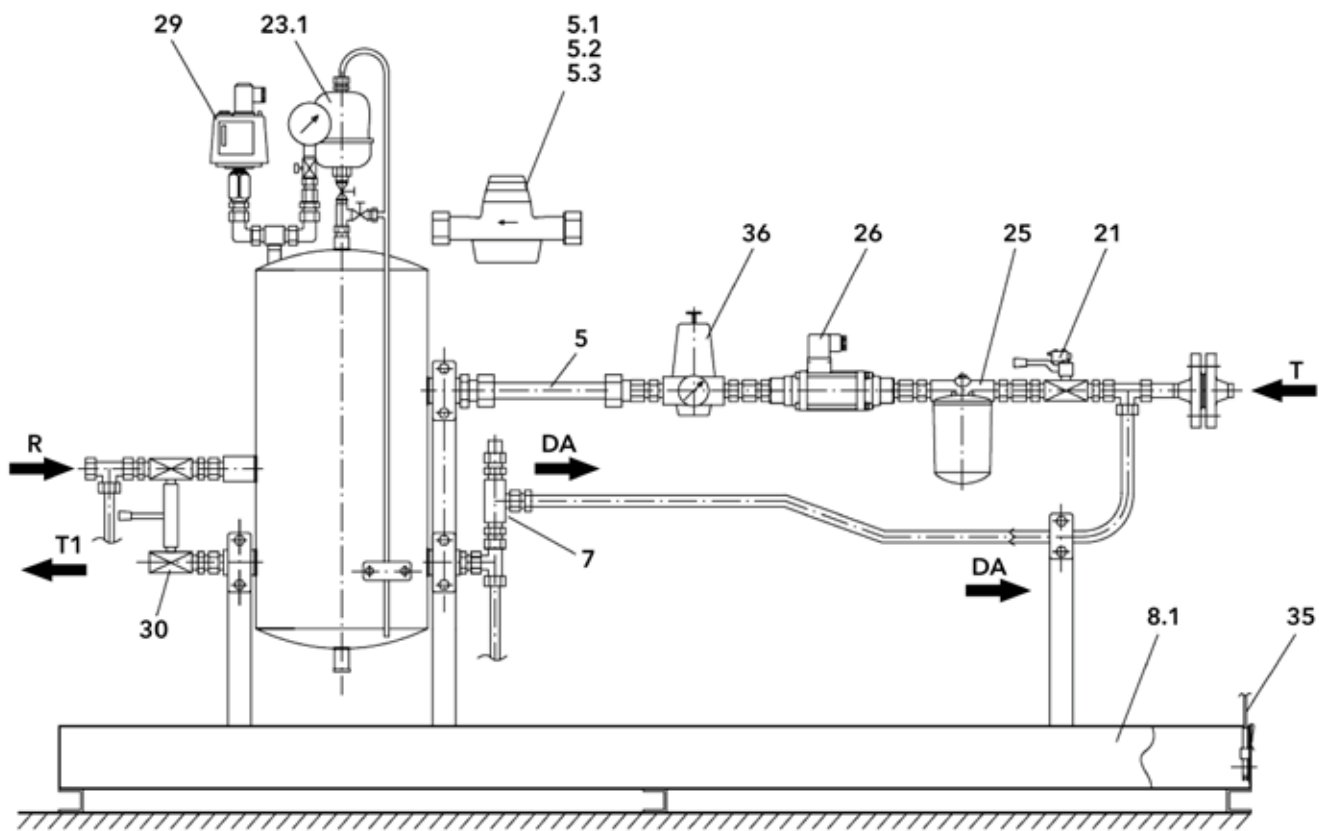

Ref.	Brief description	Description	LBA 600 A	LBA 1200 A	LBA 2400 A	LBA 3000 A
5.1	HZ	Oil meter	VZO 15 to 25 RC			
5.2	RV	Pulse generator RV (Reed)	RV = 0,1 for VZO 15; RV = 1 for VZO 20 - 40			
5.3	IN	Pulse generator IN (Inductive)	IN = 0,1 for VZO 15; IN = 1 for VZO 20 - 40			
21	EE	End position switch, including bracket	230 V / 50 Hz / IP65, mounted onto ball valve, tested at installation			
23	G / SE	Automatic float air vent for optimum ventilation	Rp3/8", PN16, 150°C			
25	EF	Fuel filter	Rp3/4", PN10, 100µ	Rp3/4", PN10, 100µ	Rp1", PN6, 100µ	Rp1", PN6, 100µ
26	M	Piston solenoid valve, DIN & TÜV tested	Rp1/2" - DN10	Rp1/2" - DN10	Rp3/4" - DN15	Rp1" - DN15
29	S	Oil pressure switch	Rp1/2", 230 V / 50 Hz, setting range 0,5 ... 6 bar			
30	DK	Double ball valve combination	Rp1/2"	Rp3/4"	Rp3/4"	Rp1"
35	LH	Leakage detector integrated into oil pan, type LMW	230 V / 50 Hz / IP65, sensor length: 1,5 m			
36	DM	Pressure regulator valve	0,2 ... 2,5 bar			
7	DA	Pressure equalization as safety valve with component test available at an additional cost, set to 3 bar with sealing cap				

All codes on request.

OIL CONNECTION UNIT

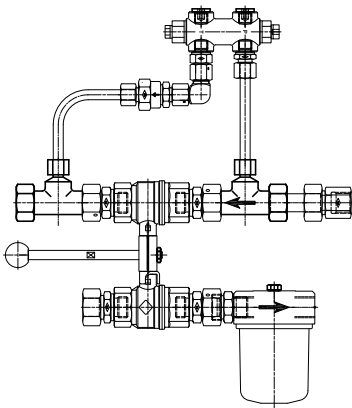

Unit consists of:
 - double ball valve (with or without limit switch);
 - oil filter
 - safety valve with relief valve, non return valve
 - pipes, threaded connections, seals

Unit with double ball valve with limit switch	Rp 1/2"	3755291
	Rp 3/4"	3754259
	Rp 1"	3755292
Unit with double ball valve without limit switch	Rp 1/2"	14037863
	Rp 3/4"	14037874
	Rp 1"	14037885

MANOMETER

 <p>Manometer/vacuometer glycerine-filled Connection Rp1/2" A radial</p>	-1...+3 bar	1098748467
	-1...+5 bar	1098748478
	0...4 bar	1098748489
	0...6 bar	3333116345
	0...10 bar	1098748490
	0...16 bar	1098585471
	0...25 bar	3333261128
	0...40 bar	1090160374
	0...60 bar	1098114290
Kit manometer hydraulic block N6/N7		3755398



LEAKAGE CONTROL DEVICE

	Signal device for oil for wall mounting LMW with 1 optoelectronic detector, signal part in housing HxBxT=140x85x60mm 230 V / 50-60 Hz / IP40	
	with cable 1,5 m	3755932
	with cable 15 m	3755933
	with cable 30 m	3755934

AIR VALVE

Automatic air valve with ball valve Rp3/8"	1478812577
--	------------

RELIEF/PRESSURE MAINTAINING VALVE

		Connection (DN)	Fuel rate	Pressure	
 <p>Threaded design, directly adjustable, with spring load for keeping adjusted working and max pressure, viscosity range 2,8...480 cSt</p>	1/4"	6...120 l/h	0,5...1,5 bar	1478812044	
			1...4 bar	1478730083	
			2...9 bar	1478731940	
		3/8"	15...160 l/h	0,5...1,5 bar	1478812055
				1...4 bar	1478812066
				2...9 bar	1478812077
	1/2"	30...600 l/h	0,5...1,5 bar	1478812088	
			1...4 bar	1478720874	
	3/4"	100...2000 l/h	2...9 bar	1478812099	
			0,5...3,5 bar	1478812102	
	1"	300...6000 l/h	2...9 bar	1478812113	
			0,5...1,5 bar	1478812124	
			1...4 bar	1478812135	
	1 1/4"	500...10000 l/h	2...9 bar	1478812146	
			0,5...1,5 bar	1478812157	
			1...4 bar	12001314	
	 <p>Flanged design, directly adjustable, with spring load for keeping adjusted working and max pressure, viscosity range 2,8...480 cSt</p>	DN15	30...600 l/h	0,5...1,5 bar	1478812179
				1...4 bar	1478729973
2...9 bar				1478812180	
DN20		100...2000 l/h	0,5...3,5 bar	1478812191	
			2...9 bar	1478812204	
DN25		300...6000 l/h	0,5...1,5 bar	1478812215	
			1...4 bar	1478785851	
			2...9 bar	1478812226	
DN32		500...10000 l/h	0,5...1,5 bar	1478812237	
			1...4 bar	1478812248	
			2...9 bar	1478812259	

WELDED FLANGE

	Welded flange PN 16 according to DIN 2633, form C from RSt 37-2 as external flange for oil mounting PN16	DN15	5318675203
		DN20	3333101876
		DN25	5318353059
		DN32	5318704652
		DN40 x 42 mm	5318353048
		DN50 x 45 mm	5318428082
	Welded flange PN40 according to DIN 2635, form C from C22 as external flange for oil mounting PN40	DN15	5318557486
		DN20	3333101916
		DN25	5318556494
		DN32	5318556507
		DN40 x 42 mm	5318556518
		DN50 x 45 mm	5318575308

SEALS AND CONNECTING KIT

Screwing set: 1 seal, pin screws, hexagon nuts, lining washer	DN15 PN16 / PN40	3752201
	DN20 PN16 / PN40	3752202
	DN25 PN16 / PN40	3752203

BALL VALVE

0...60°C for 64 bar, 0...120°C for 40 bar, 20...150°C for 30 bar	1/4"	1478736157
	1/2"	1478736168
	3/4"	1478736179
	1"	1478736180
-20...150°C for 16 bar	DN25	1478732910
	DN32	1478732921
	DN40	1478732932
	DN50	1478732943
	DN65	1478732954
	DN80	1478732965
-20...120°C for 40 bar, -20...150°C for 30 bar	DN15	1478734938
	DN20	1478734949
	DN25	1478734950
	DN32	1478734961
	DN40	1478734972
	DN50	1478734983

LIGHT OIL FILTER

300 - 100 l/h	Rp3/8" male (burner side) / female - 70 µm - one pipe	3333110172
700 - 200 l/h	Rp1/2" female (burner side) / female - 75 µm - one pipe	3333115483
300 - 100 l/h	Rp3/8" male (burner side) / female - 70 µm - two pipes	3333110175
700 - 200 l/h	Rp1/2" female (burner side) / female - 75 µm - two pipes	3755728

OIL FILTER FD FOR SUCTION AND PRESSURE OPERATION

 <p>Oil pressure max. 2 bar</p>	Rp 1/2" - 700 l/h	3754100
	Rp 3/4" - 1700 l/h	3754101
	Rp 1" - 2000 l/h	3754102

LIGHT OIL FLOW COUNTER

Without pulse transducer	10 ... 400 l/h 16 bar Rp1/2"	1368746803
	10 ... 400 l/h 16 bar DN15	1368746892
	30 ... 1000 l/h 16 bar Rp3/4"	1368746836
	30 ... 1000 l/h 16 bar DN20	1368746927
	75 ... 2000 l/h 16 bar Rp1"	1368746869
	75 ... 2000 l/h 16 bar DN25	1368746950
With pulse transducer RV 0,1 (Reed)	10 ... 400 l/h 16 bar Rp1/2"	1368746814
	10 ... 400 l/h 16 bar DN15	1368746905
	30 ... 1000 l/h 16 bar Rp3/4"	1368746847
	30 ... 1000 l/h 16 bar DN20	1368746938
	75 ... 2000 l/h 16 bar Rp1"	1368746870
	75 ... 2000 l/h 16 bar DN25	1368746961
With pulse transducer IN 0,01 (Inductive)	10 ... 400 l/h 16 bar Rp1/2"	1368746825
	10 ... 400 l/h 16 bar DN15	1368746916
	30 ... 1000 l/h 16 bar Rp3/4"	1368746858
	30 ... 1000 l/h 16 bar DN20	1368746949
	75 ... 2000 l/h 16 bar Rp1"	1368746881
	75 ... 2000 l/h 16 bar DN25	1368746972
Threaded connection	VSR - Rp1/2"	3753933
	VSR - Rp3/4"	3754536
	VSR - Rp1"	3755097

Subsidiaries ELCO

GERMANY

ELCO GmbH
Dreieichstraße 10
Mörfelden-Walldorf
Tel.: +49 (0) 6105 287-287
Fax: +49 (0) 6105 287-199

NETHERLANDS

Elco Burners B.V.
Meerpaalweg, 1 - 1332 BB Almere
P.O. box 30048 - 1303 AA Almere
Tel.: +31 088 69 573 11
Fax: +31 088 69 573 90

SWITZERLAND

Elcotherm AG
Sarganserstrasse 100
7324 Vilters
Tel.: +41 (0)81 725 25 25
Fax: +41 (0)81 723 13 59

AUSTRIA

ELCO Austria GmbH
Aredstraße 16 - 18
2544 Leobersdorf
Tel.: +43 (0)2256 639 99 32
Fax: +43 (0)2256 644 11

FRANCE

14, rue du Saule Trapu
Parc d'activité du Moulin
91882 Massy
Tel.: +33 01 60 13 64 64
Fax: +33 01 60 13 64 65

ITALY

Via Roma, 64
31023 Resana (TV)
Tel.: +39 0423 719500
Fax: +39 0423 719580

UK & IRELAND

Ariston Thermo UK Ltd
Suite 3, The Crown House
Blackpole East, Blackpole Road,
Worcester WR3 8SG
Tel.: +44 01905 788010

CHINA

Ariston Heating Solutions (China) Co., Ltd.
25th floor, T1, Shanghai T-Center
No. 1428 Daduhe Road, Putuo District, Shanghai
Tel.: +86 21 6039 8691
Fax: +86 21 6039 8620

Contact us to know more
about our products and solutions

www.elco-burners.com
contact@elco-burners.com

Version 2.1 | 23/08/2024

All rights reserved | ELCO declines all responsibility for any printing mistakes or any content transcription in the present document and reserves the right to modify, without prior notice, any product datas or characteristics