

# elco

## PROTRON

MONOBLOCK BURNERS

17 - 546 kW



# PROTRON

## Designed for light industry applications: ovens, dryers, spray booths, incinerators, hot air generators

### Reliable heating solutions for every requirement

Wherever small or medium-scale heating solution is needed, ELCO is the best partner you can rely on. A comprehensive offer of tailor-made solutions is proposed by ELCO and offered by its worldwide network of distributors.

A partner in professional heating offering a wide range of burner operations to fit individual and commercial needs with optimum combustion technology respectful of sustainable environment.

### A complete range dedicated to light industry

With its new gas and light oil burners series, ELCO offers a wide range of all-duty burners for light industry applications, developed in more than 80 years of research.

All PROTRON models are characterized by economical consumption, ease of installation, adjustment and maintenance, high temperature resistance and a wide possibility of customization in order to meet any type of installation request: each burner can be customized with head length, gas train and 8 combinations of software programming.

PROTRON burners are also equipped with an integrated display featuring a communication system based on symbols and numerical data, ensuring an easy and intuitive interaction between the user and the burner.

ELCO offers its new models with a wide range of choice. PROTRON range is available in two distinct machine architectures –gun and cubic– taking advantage of the benefits of each in order to better fit to the customer needs.

### Gun

Ranging from the output of 17 to 546 kW PROTRON models with gun structure are suitable to work in gas and in light oil, available in one and two stages operation, and Low NOx emissions class 3 (<80 mg/kWh) when working in gas and class 2 (<185 mg/kWh) in light oil, according to EN676 and EN267 standards.

### Cubic

The cubic program, ranging from the output of 30 to 210 kW, is available in one and two stages operation and Low NOx emissions class 2 (<120 mg/kWh) and class 3 (<80 mg/kWh) in gas operation and class 2 (<185 mg/kWh) in light oil, according to EN676 and EN267 standards.

### Competent advice

Your contacts at ELCO and its partners are recognized experts with years of experience. Our worldwide support starts from concept creation to planning, design and project management up to commissioning and on-going operation of the plant throughout its life cycle.

### Contents

Main features	4 - 5
PROTRON operations and Systems	6 - 7
PROTRON range overview and designation	8 - 9
Gas range working fields and technical data	10 - 13
Light oil range working fields and technical data	14 - 17
Gas trains dimensions	18
Gas trains matching	19

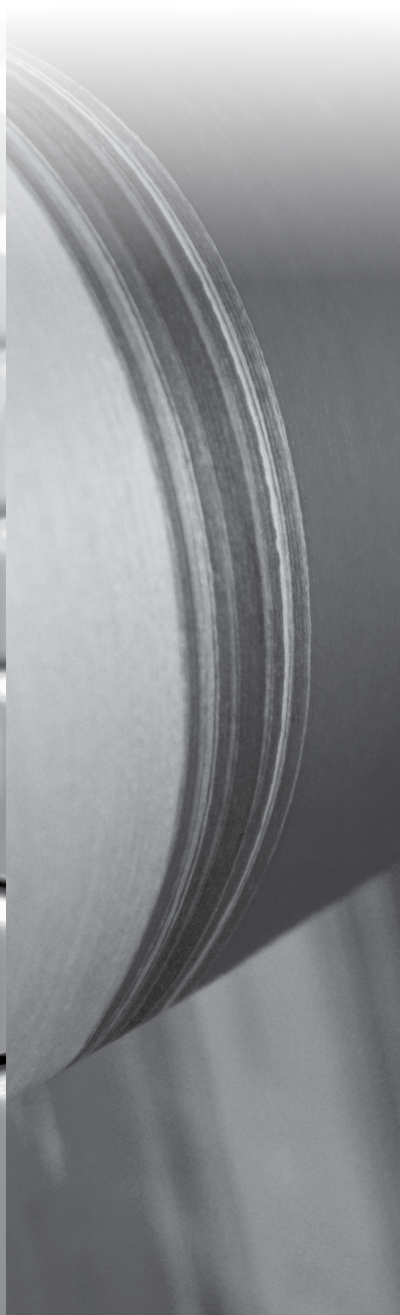

# MAIN CHARACTERISTICS OF THE RANGE

## Communication

### An intuitive and interactive system

The new MDE2 System and the Elcogram, equipped on PROTRON range constantly give real-time information to professional operators.

- **During the commissioning**

The setting of all necessary parameters for the burner operation is carried out by a user-friendly method thanks to the 5 buttons and the big size display.

- **During the burner operation**

The instantaneous data of each ignition follow one another in real time, allowing a quick check of the burner running (voltage value, flame signal, time for ignition...).

- **At each operation cycle**

The system records every event that happened during the last heating season and displays the stored data in the form of statistics.

#### 1 stage burners

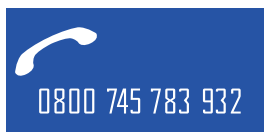

#### Elcogram, a universal language

As ELCO products are distributed worldwide, the company has developed a universal language composed of pictograms and numerical data. The pictograms use the majority of the symbols used on the wiring diagrams which are recognised and understood by all Nations. This ensures that information is easier to read than ever before.

#### 2 stages burners

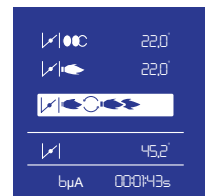
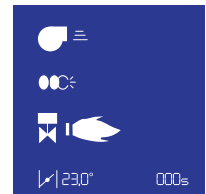

## Maintenance

### Rapid and easy maintenance solutions

In order to grant cost benefits and high performance on all ELCO burners, we implemented features that simplify commissioning and allow quick and efficient burner maintenance.

- **Quick: reduces downtime and cost of maintenance**

- **Efficient: grants optimal performance like after first commissioning**

For an easier maintenance, the combustion parts can be quickly removed, easily cleaned and, even when they are disassembled, they easily get back to their position after all the servicing work.

The RTC System developed by ELCO guarantees a simple commissioning and exceptional operation in any condition.

# Reliability

## High performance in any scenarios

A necessary feature for process industry applications is the reliability, and the PROTRON range ensures it in all conditions, even when operating at high temperatures.

All PROTRON models have been designed with metal parts where high temperature can be reached, assuring the continuity of the operation even in the most extreme situations.

The integral protection cover provides compactness and reduced space requirements, and protects the burner components in every working conditions.



# Burner structure

## High flexibility in any installation

- **Flexible configuration:**  
quick start, tightness control, adjustable pre-purge and post-purge, permanent ventilation
- **Flexible range:**  
short or long head, sliding flange, class 2 or class 3, one stage or two stages
- **Designed for applications:**  
heat resistant, compact layout, easy maintenance, integral protection cover, graphic display



Burner with **gun structure:**  
high performance ventilation  
and maximum compactness.

Burner with **cubic structure:**  
fully enclosed burner with optimal  
accessibility and flexibility.



# PROTRON OPERATIONS AND SYSTEMS

## RTC System

### Innovative solutions for quick and easy maintenance

The functional design of the housing, coupled with the innovative technology of the combustion heads, creates the RTC® (Retained Head Adjustment), offering several advantages:

- full access to all components, by simply removing the cover;
- simple and rapid maintenance;
- complete removal of the combustion head and access to its internal components with a single operation, without removing the burner from the boiler or disconnecting the gas train;
- prolonged retention of the optimum combustion head settings, which are not changed during service operations;
- rapid cleaning of the mechanical components, thanks to their clear layout;
- reduced servicing times through the use of standard nuts, bolts, screws and pipe fittings, which can be adjusted using only a few tools.



## MDE2 System

### Permanent communication of information easy to use

With its new MDE2® System and the integrated display, PROTRON burners provide constant information updates for professionals and users.

Instantaneous data (starting cycle, voltage measurement values and flame signal, etc.) and stored data (operating statistics) are now displayed.

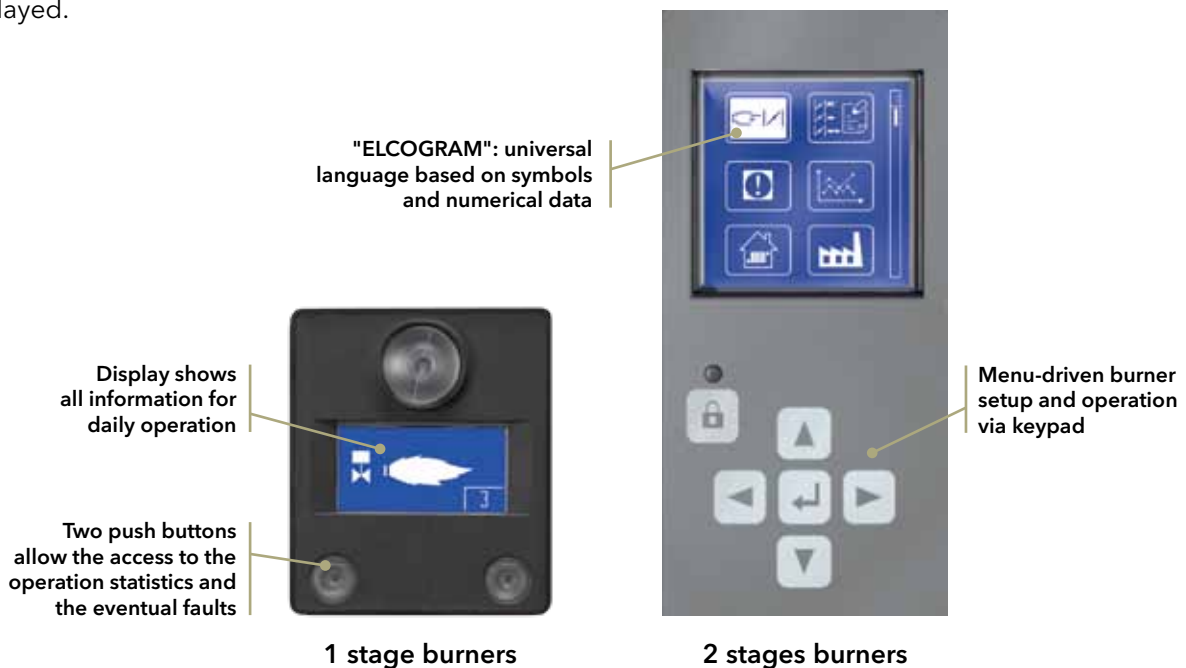

# Quick Start System

## High performance in process application



Quick Start® is dedicated to industrial applications that requires temperature stability for process and production without any interruption.

For the first start-up, there is a long preventilation period, adjustable from 40 to 300 seconds.

After a controlled shutdown, the flame is turned off when temperature is reached, then the flame is restored in a few seconds when the temperature drops.

For gas burners, a tightness control is required each time the burner stops. This means:

- an increase in productivity that results from a minimum temperature variation;
- a primary and secondary energy savings;
- no thermal shock suffered by materials used to huge temperature variations;
- a really good security thanks to permanent control device.

## Software programming

### Wide possibilities of application

PROTRON burners are characterized by high versatility allowing this range to be used in several installations within the process industry. The range has been accurately developed to ensure a level of flexibility as never before, giving to the end user the possibility to meet any installation request: each burner is configurated in factory by our technicians according to the customer needs through a serie of parameters and options, such as:

- quick start;
- tightness control;
- adjustable pre-purge and post-purge;
- permanent ventilation.

With the aim to give to the customer the maximum flexibility ELCO provides 8 combinations of software programming:

Tightness control	Function
no	Standard
yes	Standard
yes	Post ventilation
yes	Quick start + permanent ventilation, pre-purge 30" at first heat demand
yes	Quick start + permanent ventilation, pre-purge 60" at first heat demand
yes	Quick start + long pre-purge 40" at first power supply
yes	Quick start + long pre-purge 300" at first power supply
yes	Quick start + long pre-purge 600" at first power supply

# RANGE OVERVIEW

Gas range  
17 - 500 kW



## OVERVIEW OF GUN BURNERS

Burner model	Structure	Output range (kW)	Operation			
			1 stage		2 stages	
			Class 2	Class 3	Class 2	Class 3
P1.40	Gun	17 ... 48		●		
P1.70	Gun	34 ... 70		●		
P1.105	Gun	49 ... 108		●		
P2.130	Gun	40 ... 120		●		
P2.170	Gun	55 ... 175		●		●
P2.250	Gun	55 ... 240		●		●
P3.350	Gun	100 ... 350		●		●
P3.500	Gun	120 ... 500		●		●



## OVERVIEW OF CUBIC BURNERS

Burner model	Structure	Output range (kW)	Operation			
			1 stage		2 stages	
			Class 2	Class 3	Class 2	Class 3
P2.70	Cubic	33 ... 70	■		■	
P2.120	Cubic	40 ... 130	■	■	■	■
P2.160	Cubic	60 ... 180	■	■	■	■
P2.210	Cubic	80 ... 210		■		■

## DESIGNATION

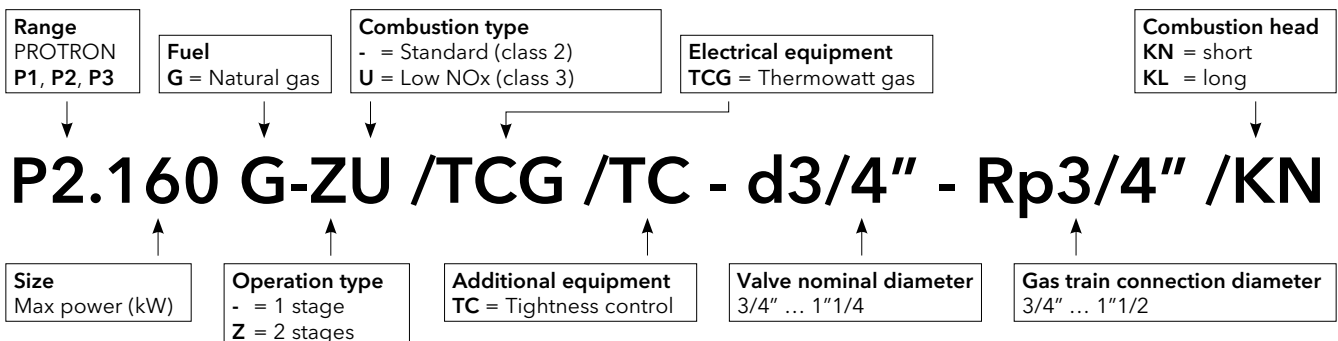



# RANGE OVERVIEW

Light oil range  
18 - 546 kW



## OVERVIEW OF GUN BURNERS

Burner model	Structure	Output range (kW)	Operation			
			1 stage		2 stages	
			Class 2	Class 3	Class 2	Class 3
P1.40	Gun	18 ... 41	●			
P1.60	Gun	20 ... 59	●			
P1.105	Gun	47 ... 105	●			
P2.130	Gun	60 ... 130	●			
P2.190	Gun	74 ... 190	●		●	
P2.240	Gun	87 ... 237	●			
P2.300	Gun	102 ... 319	●		●	
P3.430	Gun	166 ... 427			●	
P3.550	Gun	202 ... 546			●	



## OVERVIEW OF CUBIC BURNERS

Burner model	Structure	Output range (kW)	Operation			
			1 stage		2 stages	
			Class 2	Class 3	Class 2	Class 3
P2.70	Cubic	30 ... 70	■		■	
P2.120	Cubic	45 ... 140	■		■	
P2.160	Cubic	90 ... 175	■		■	
P2.210	Cubic	130 ... 210	■		■	

## DESIGNATION

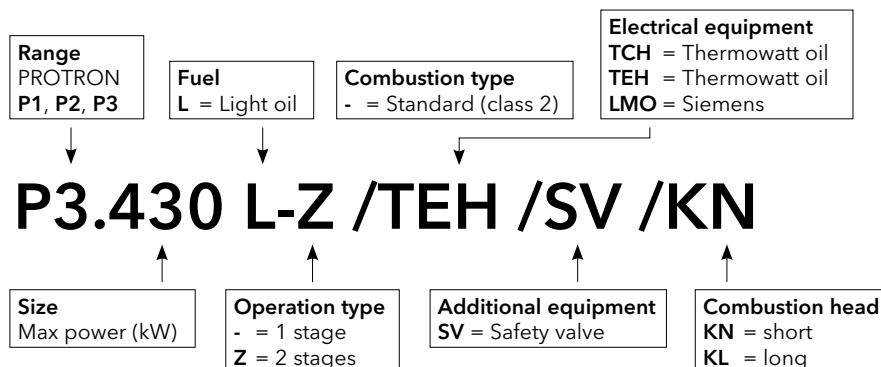

# TECHNICAL DATA | GAS RANGE

## ● Gun

### ● P1 G-U, P2.130 G-U

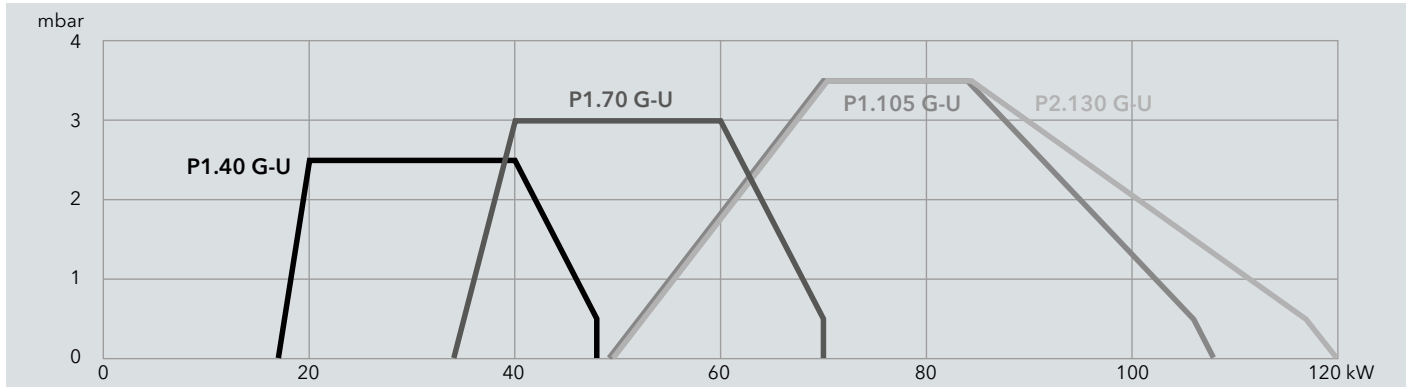

### ● P2 G-U, P2 G-ZU

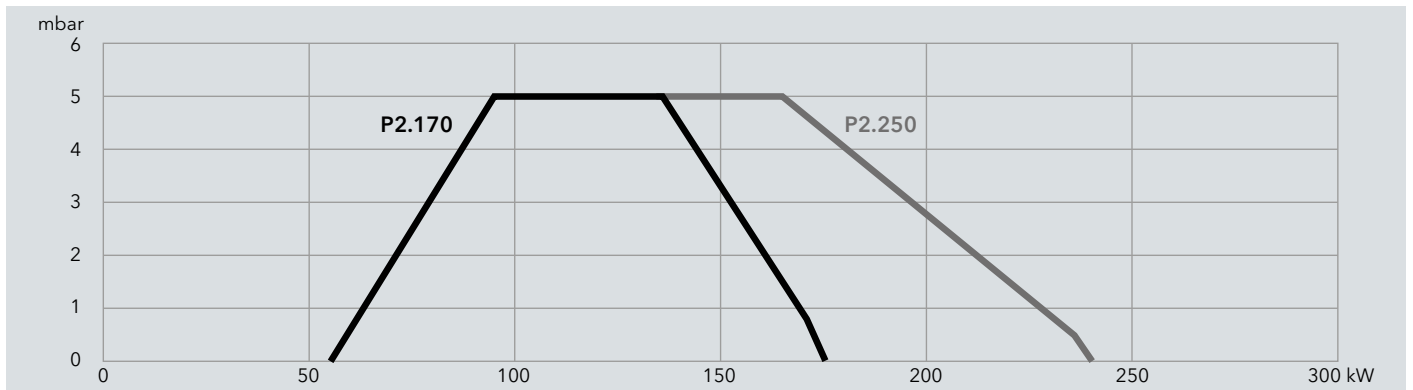

### ● P3 G-U, P3 G-ZU

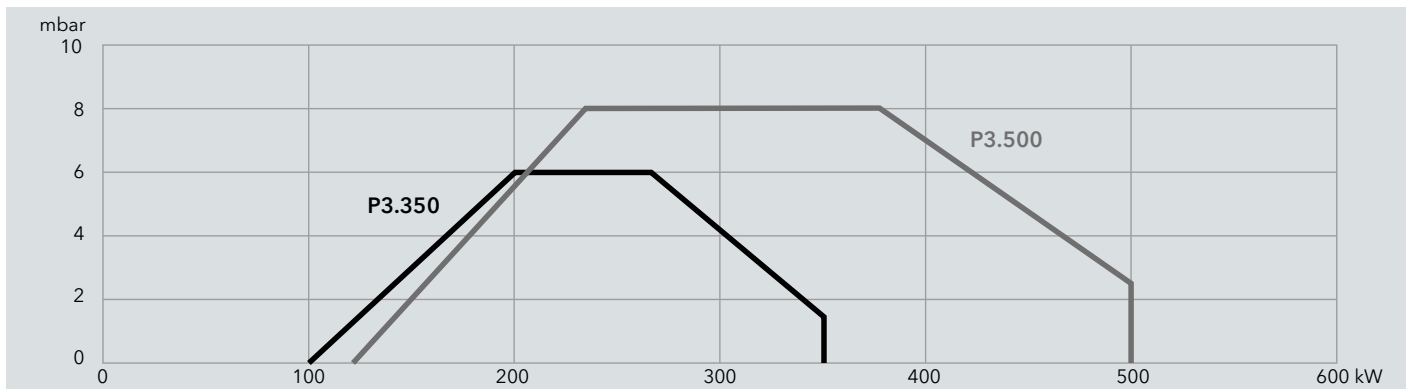

# TECHNICAL DATA | GAS RANGE

## ● Gun

- P1 G-U
- P2.130 G-U

P1.40 G-U

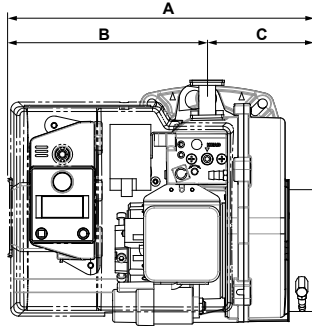

P1.70/105 G-U, P2.130 G-U

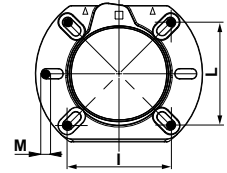
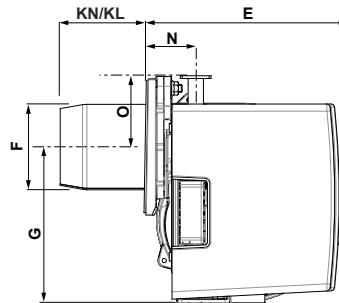
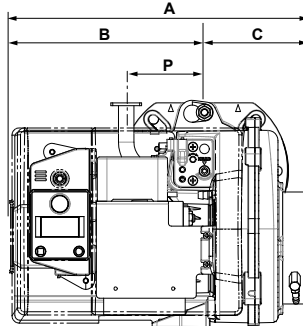

Model	A	B	C	KN	KL	E	F	G	I	L	M	N	O	P		
P1.40 G-U	290	188	102	85	143	191	89	160	KN 92/107	KL 96/116	KN 92/107	KL 96/116	M8	54	73	-
P1.70 G-U	306	200	106	85	143	209	89	160	KN 100/120	KL 96/116	KN 100/120	KL 96/116	M8	52	71	82
P1.105 G-U	306	200	106	140	178	209	89	160	KN 100/120	KL 96/116	KN 100/120	KL 96/116	M8	52	71	82
P2.130 G-U	306	200	106	160	240	209	98	160	KN 100/120	KL 100/120	KN 100/120	KL 100/120	M8	52	71	82

- P2 G-U
- P2 G-ZU

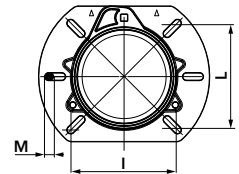
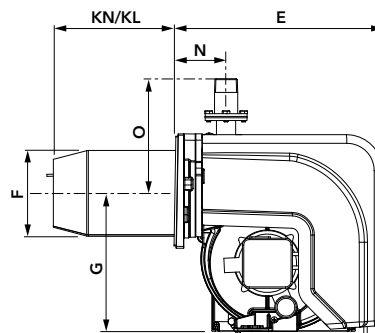
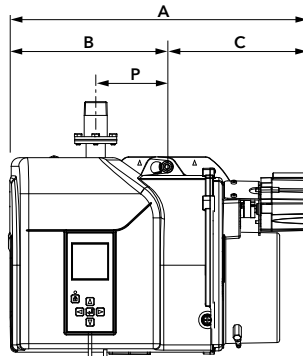
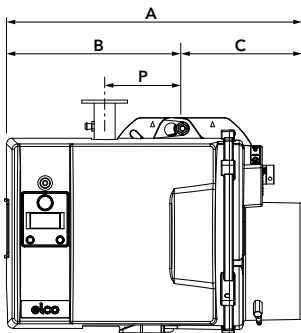

Model	A	B	C	KN	KL	E	F	G	I	L	M	N	O	P
P2.170/250 G-U	395	235	160	180	280	280	125	201	106/130	106/130	M8	73	110	104
P2.170/250 G-ZU	435	231	204	180	280	301	125	201	106/130	106/130	M8	73	110	104

- P3 G-U
- P3 G-ZU

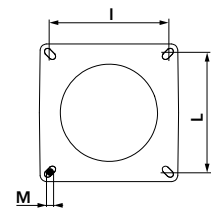
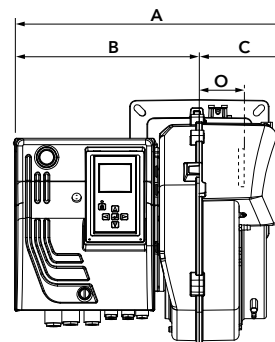
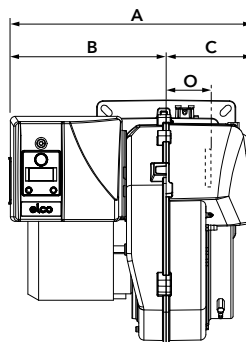
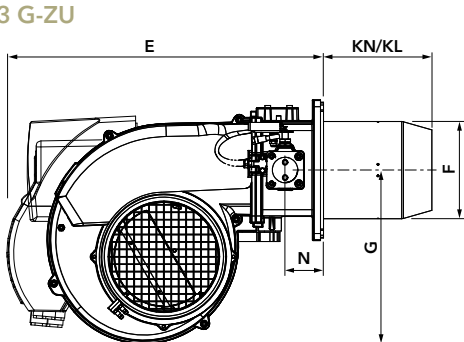

Model	A	B	C	KN	KL	E	F	G	I	L	M	N	O
P3 G-U	389	252	137	175	335	478	157	280	185/200	185/200	M8	62	101
P3 G-ZU	439	302	137	175	335	500	157	280	185/200	185/200	M8	62	101

# TECHNICAL DATA | GAS RANGE

## ■ Cubic

### ■ P2 G

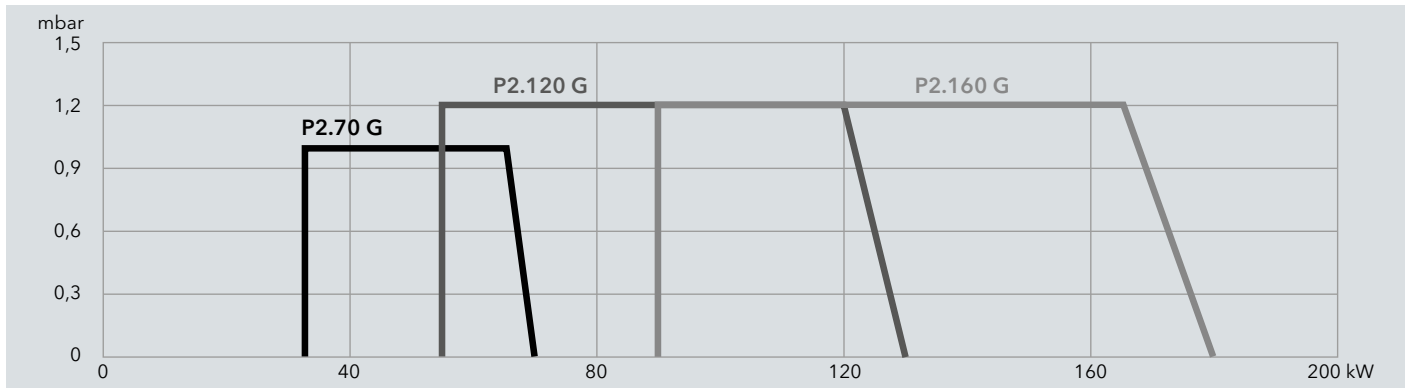

### ■ P2 G-U

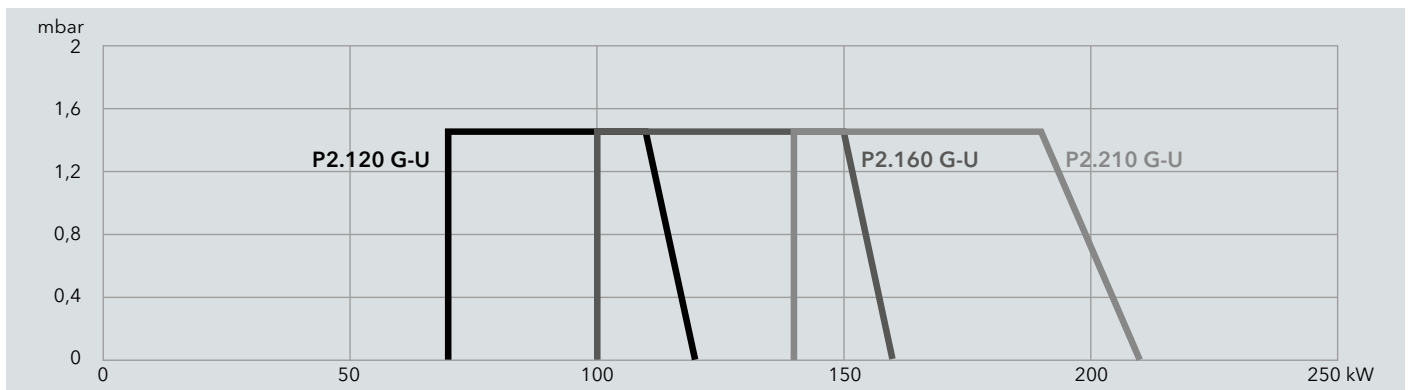

### ■ P2 G-Z

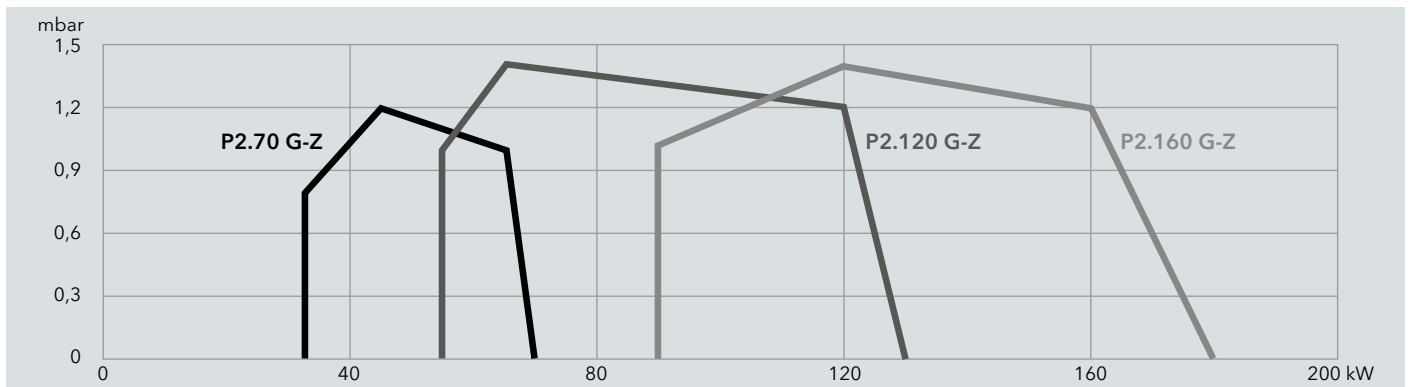

### ■ P2 G-ZU

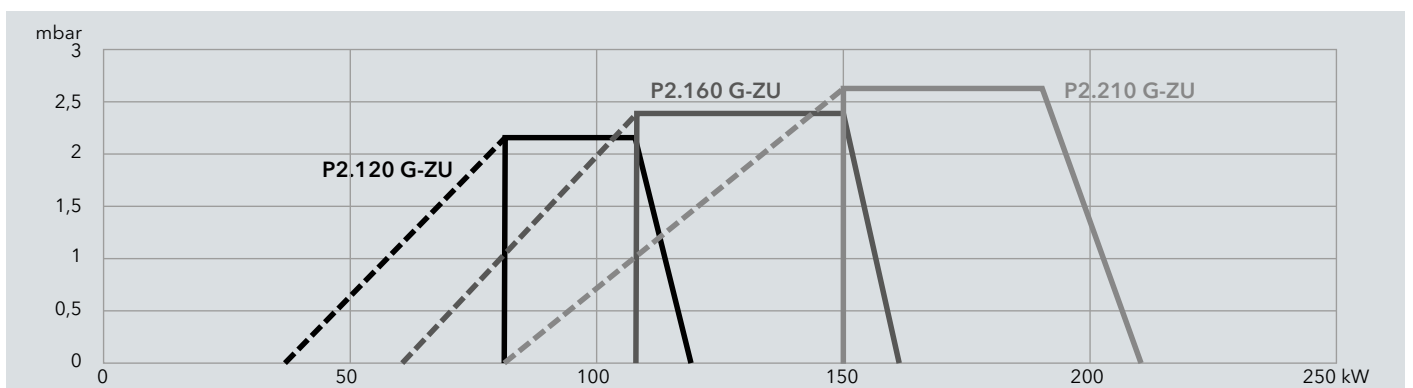

# TECHNICAL DATA | GAS RANGE

## Cubic

- P2 G
- P2 G-U

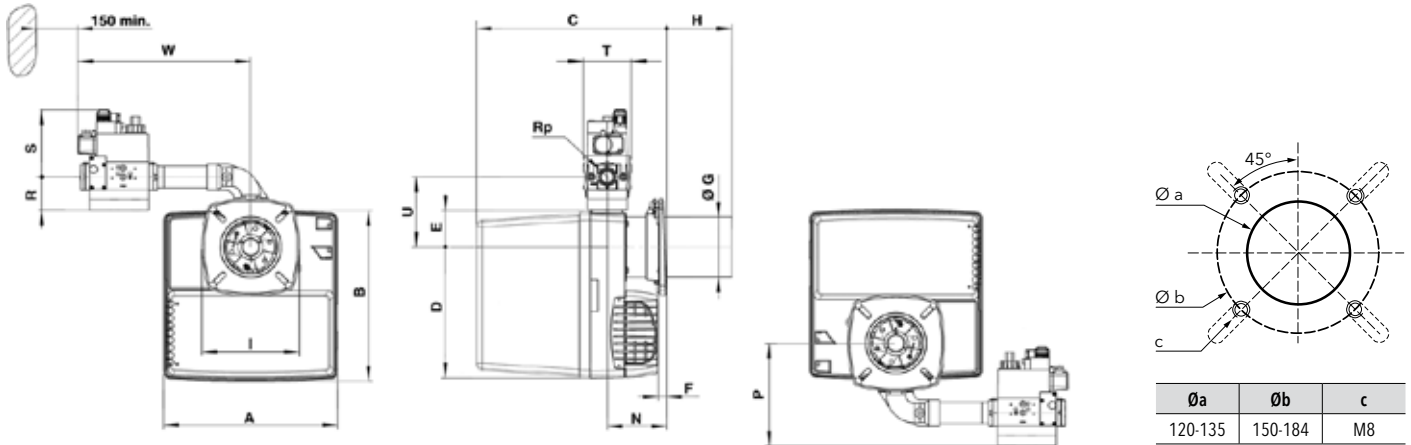

Øa	Øb	c
120-135	150-184	M8

Model	A	B	C		D	E	F	ØG	H		I	N	P	Rp	R	S	T	U	W
P2.70 G	331	325	KN	KL	256	69	15 min	100	KN	KL	185	113 min	179	3/4"	46	140	120	133	330
P2.120 G			30...115	30...270				100											
P2.160 G			115																
P2.120 G-U	331	325	KN	KL	256	69	15 min	100	KN	KL	185	113 min	179	3/4"	46	140	120	133	330
P2.160/210 G-U			30...150	30...270									188	1"1/4"	55	160	145		360
P2.160/210 G-U	331	325	KN	KL	256	69	15 min	115	KN	KL	185	113 min	179	3/4"	46	140	120	133	330
P2.160/210 G-U			30...150	30...270									188	1"1/4"	55	160	145		360

- P2 G-Z
- P2 G-ZU

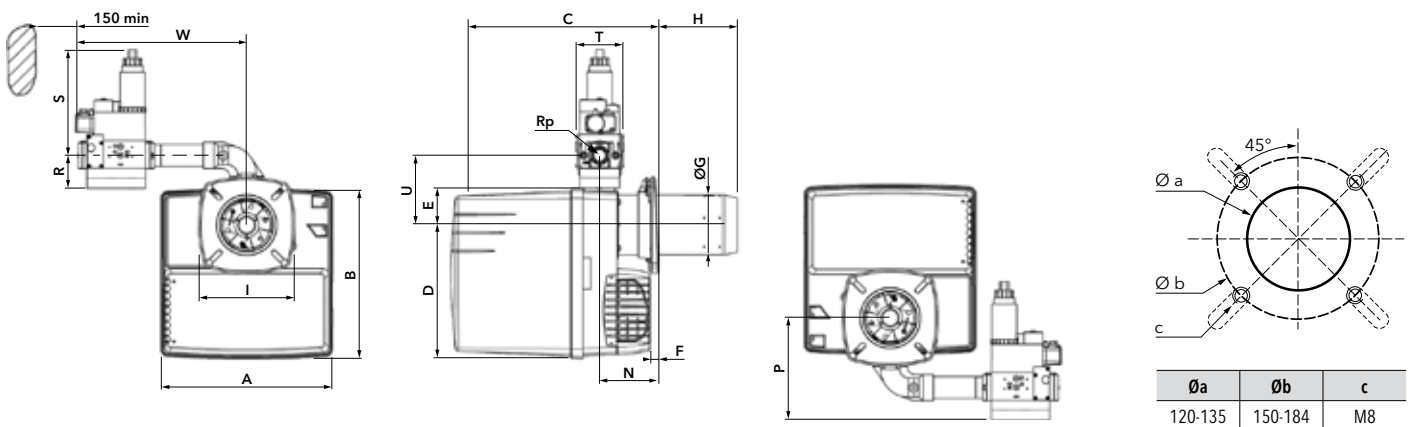

Øa	Øb	c
120-135	150-184	M8

Model	A	B	C		D	E	F	ØG	H		I	N	P	Rp	R	S	T	U	W
P2.70/120 G-Z	331	325	KN	KL	256	69	15 min	100	KN	KL	185	113 min	179	3/4"	46	210	120	133	330
P2.160 G-Z			30...150	30...270				115											
P2.120/160/210 G-ZU	331	325	KN	KL	256	69	15 min	115	KN	KL	185	113 min	179	3/4"	46	210	120	133	330
P2.120/160/210 G-ZU			30...150	30...270									188	1"1/4"	55	260	145		360

# TECHNICAL DATA | LIGHT OIL RANGE

## ● Gun

### ● P1 L, P2.130 L

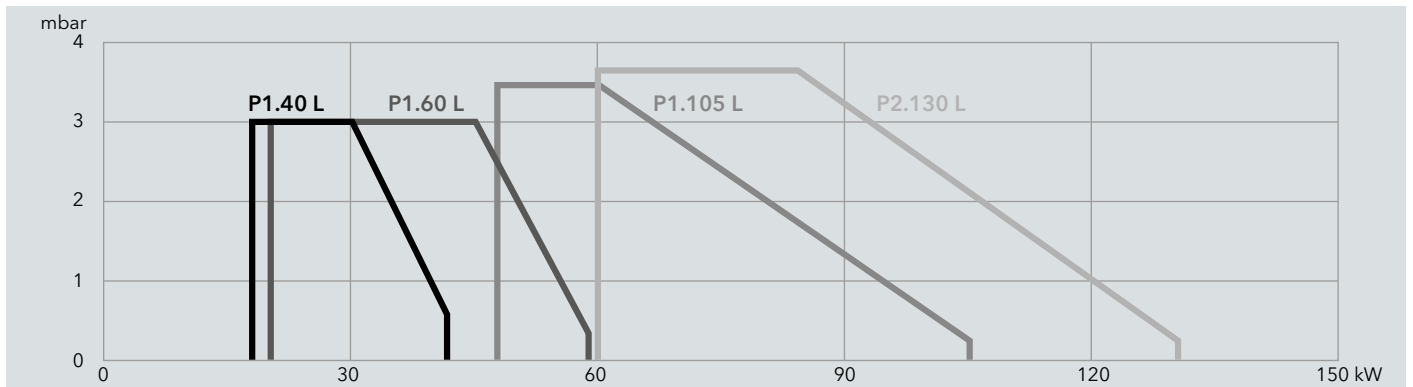

### ● P2 L

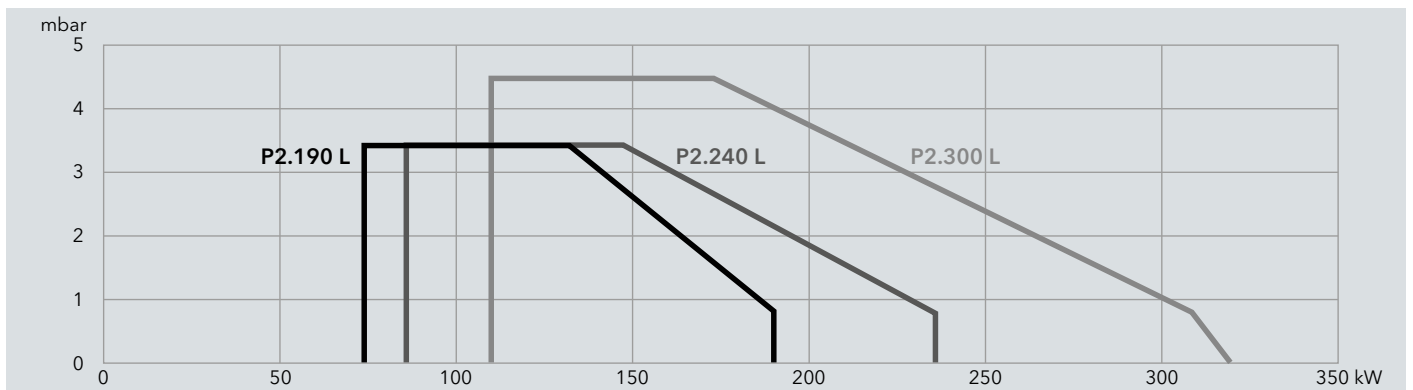

### ● P2 L-Z

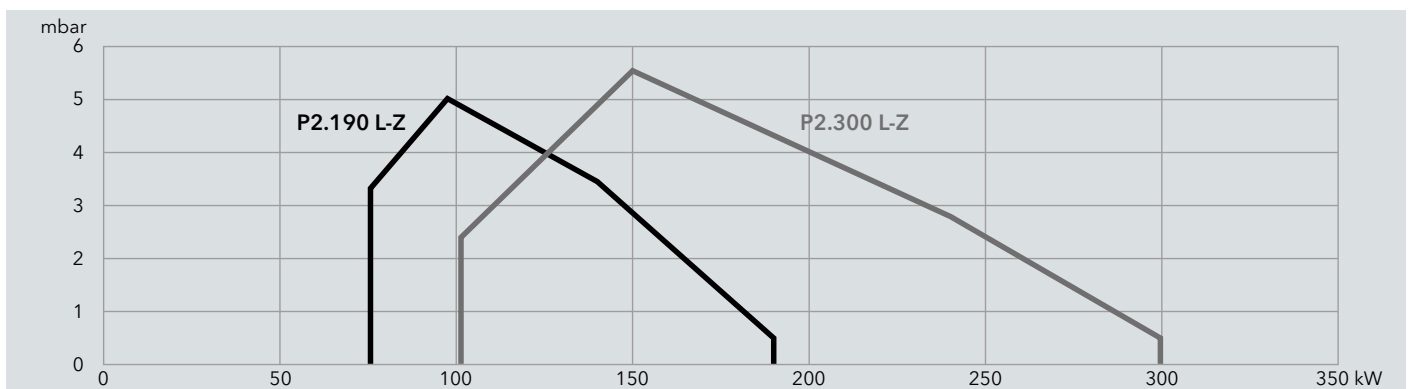

### ● P3 L-Z

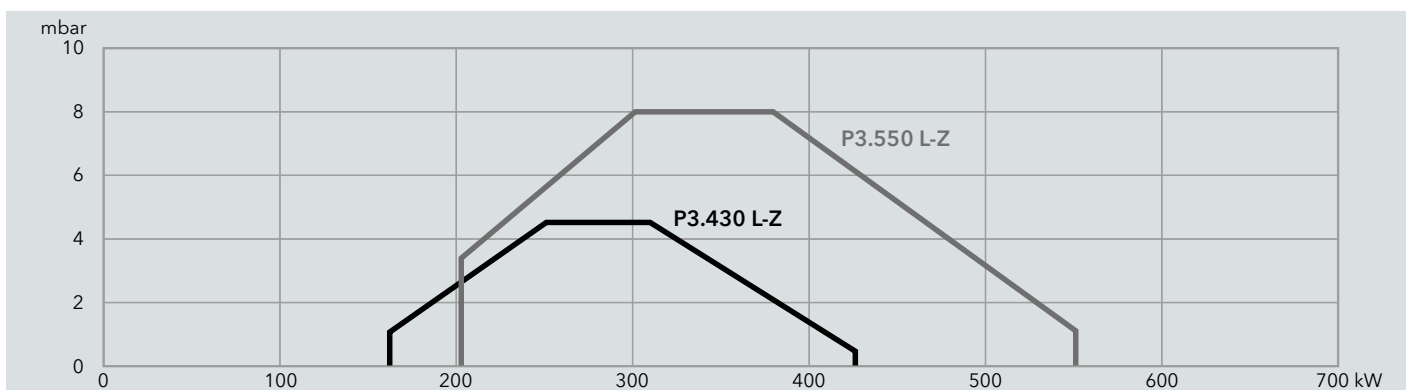



# TECHNICAL DATA | LIGHT OIL RANGE

## ● Gun

- P1 L
- P2 L

P1.40 L

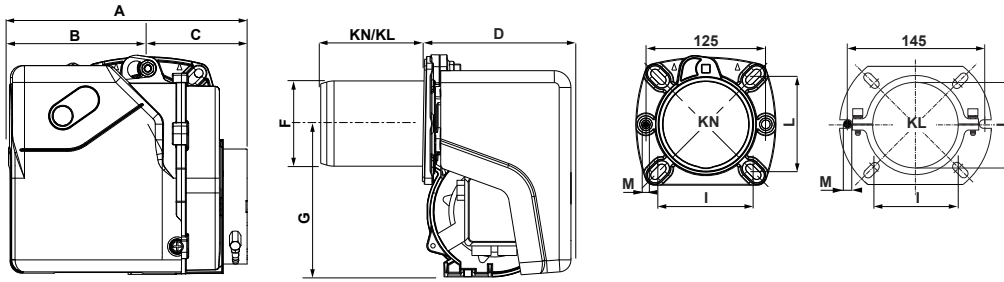

P1.60 L  
P1.105 L  
P2.130 L

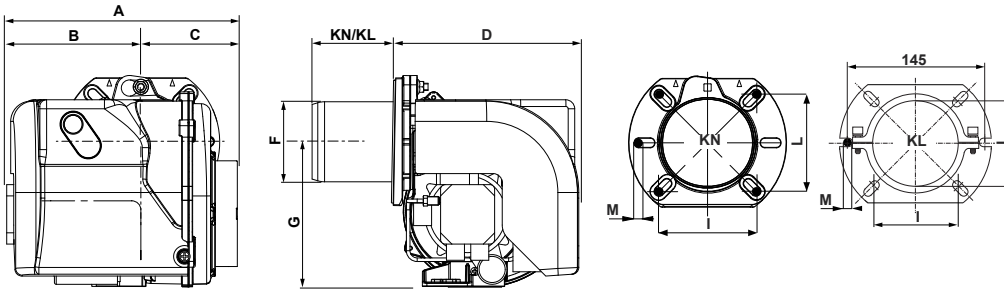

Model	A	B	C	D		E	F	G	I	L	M		
P1.40 L	245	143	102	KN 80	KL 98	153	89	160	KN 92/107	KL 96/116	KN 92/107	KL 96/116	M8
P1.60 L	255	149	106	KN 90	KL 103	204			KN 100/120	KL 96/116	KN 100/120	KL 96/116	
P1.105 L	261	155		KN 115	KL 128	204			98	KN 100/120	KL 100/120	KN 100/120	
P2.130 L	275	169											

## ● P2 L

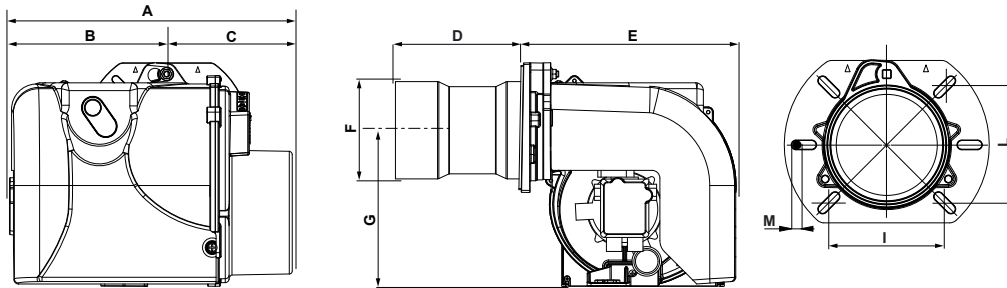

Model	A	B	C	D		E	F	G	I	L	M
P2.190 L	362	202	160	KN 160	KL 260	276	107	201	120/131	120/131	M8
P2.40/300 L	362	202	160	KN 160	KL 260	276	125	201	120/131	120/131	M8

## ● P3 L

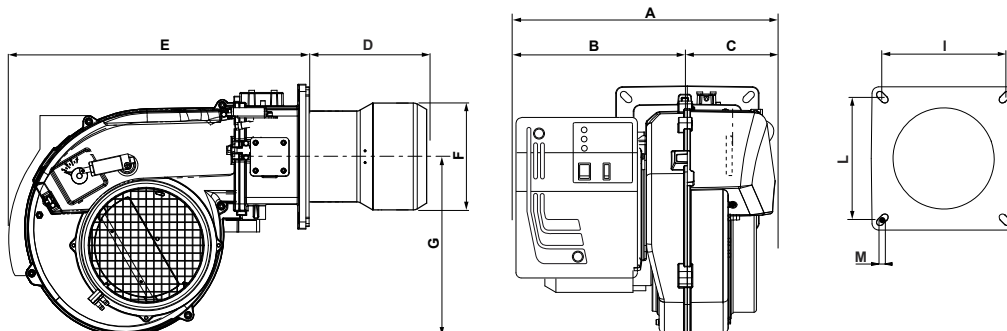

Model	A	B	C	D		E	F	G	I	L	M
P3 LZ	439	302	137	KN 175	KL 365	466	160	280	185/200	185/200	M8

# TECHNICAL DATA | LIGHT OIL RANGE

■ Cubic

■ P2 L

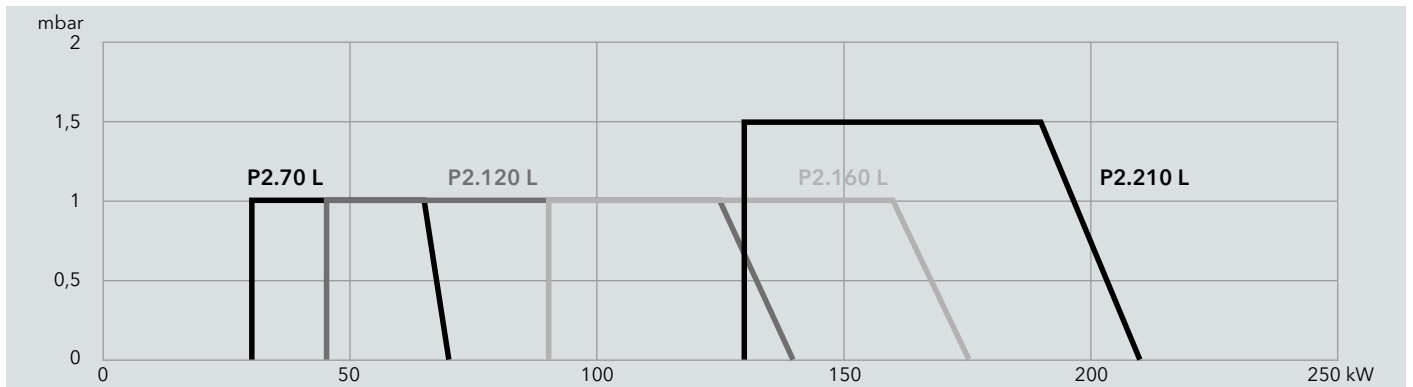

■ P2 L-Z

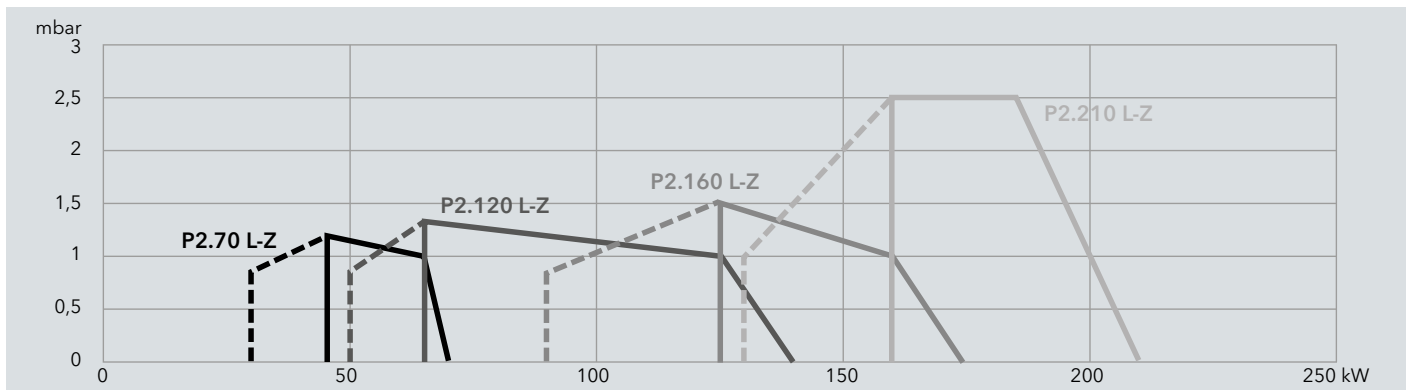

# TECHNICAL DATA | LIGHT OIL RANGE

## ■ Cubic

### ■ P2 L

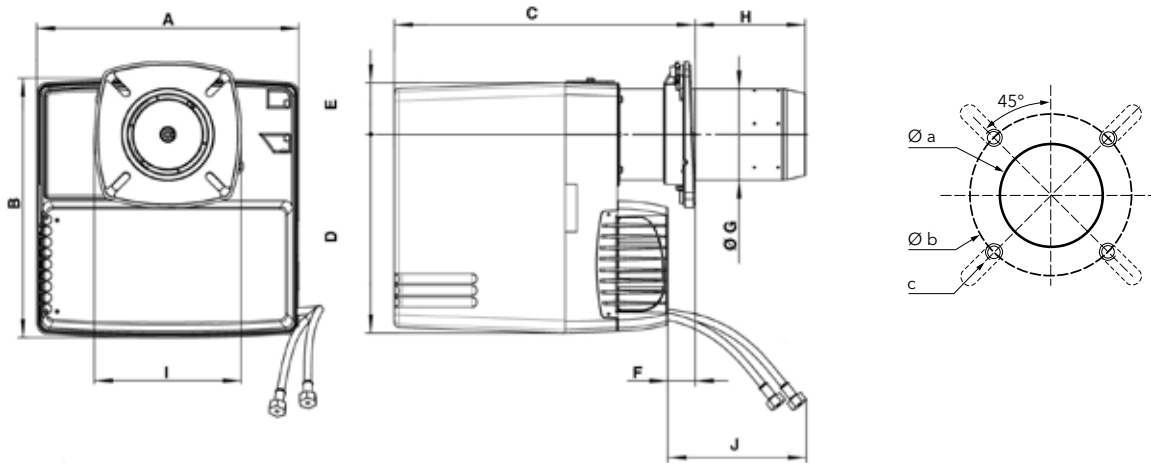

Model	A	B	C		D	E	F	ØG	H		I	J	Øa	Øb	c
P2.70 L	331	325	KN	KL	256	69	15 min	90	KN	KL	185	700	120-135	150-184	M8
P2.120 L			365...447	365...567				100	30...112	30...232					
P2.160 L			KN	KL				115	30...117	30...272					
P2.210 L			365...452	365...607											

### ■ P2 L-Z

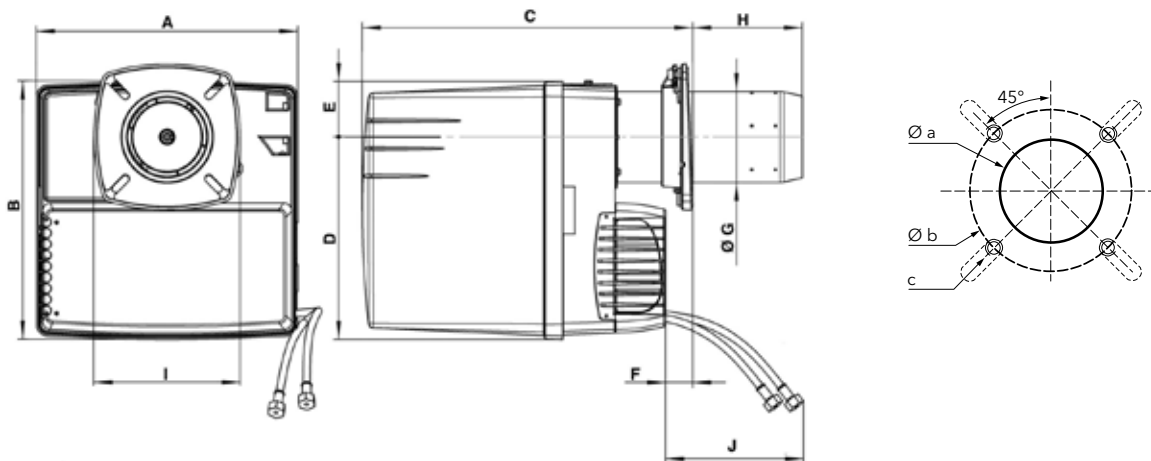

Model	A	B	C		D	E	F	ØG	H		I	J	Øa	Øb	c
P2.70 L-Z	331	325	KN	KL	256	69	15 min	90	KN	KL	185	700	120-135	150-184	M8
P2.120 L-Z			398...480	398...600				100	30...112	30...232					
P2.160 L-Z			KN	KL				115	30...117	30...272					
P2.210 L-Z			398...485	398...640											

# GAS TRAINS

## ● Gun

### ● P1.40 ... P2.250

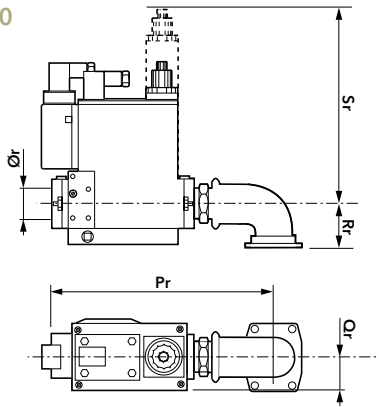

### ● P3.350 ... P3.500

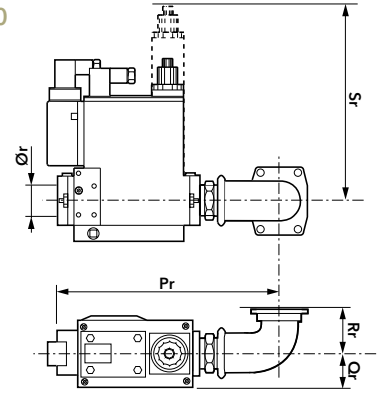

Model	Gas train designation	Ø	Pr	Qr	Rr	Sr	Ør
P1.40 G	GT-D130-3/8"-Rp1/2"	RP 15 - 1/2"	150	29	35	144	1/2"
	GT-D115-1/2"-Rp1/2"	RP 15 - 1/2"	250	42	35	140	1/2"
	GT-D116-3/4"-Rp3/4" TC	RP 20 - 3/4"	194	55	35	140	3/4"
P1.70 G	GT-D130-3/8"-Rp1/2"	RP 15 - 1/2"	150	29	35	144	1/2"
	GT-D115-1/2"-Rp1/2"	RP 15 - 1/2"	250	42	35	140	1/2"
	GT-D116-3/4"-Rp3/4" TC	RP 20 - 3/4"	194	55	35	140	3/4"
P1.105 G	GT-D117-3/4"-Rp3/4"	RP 15 - 1/2"	260	42	35	140	1/2"
P2.130 G	GT-D117-3/4"-Rp3/4"	RP 15 - 1/2"	260	42	35	140	1/2"
P2.170 G	GT-D128-3/4"-Rp3/4"	RP 20 - 3/4"	335	55	150	140	3/4"
P2.170 G-Z	GT-D235-3/4"-Rp3/4"	RP 20 - 3/4"	194	62	55	210	3/4"
P2.250 G	GT-D128-3/4"-Rp3/4"	RP 20 - 3/4"	335	55	150	140	3/4"
	GT-D127-1"1/4-Rp1"1/4	RP 32 - 1"1/4	218	62	55	160	1"1/4
P2.250 G-Z	GT-D235-3/4"-Rp 3/4"	RP 20 - 3/4"	194	62	55	210	3/4"
	GT-D239-1"1/4-Rp1"1/4	RP 32 - 1"1/4	223	62	55	260	1"1/4
	GT-D120-3/4"-Rp3/4"	RP 20 - 3/4"	335	55	150	140	3/4"
P3.350 G P3.350 G-Z	GT-D122-1"1/4-Rp1"1/4	RP 32 - 1"1/4	335	62	150	160	1"1/4
	GT-D124-1"1/2-Rp1"1/2	RP 40 - 1"1/2	400	50	150	175	1"1/2
P3.500 G P3.500 G-Z	GT-D120-3/4"-Rp3/4"	RP 20 - 3/4"	335	55	150	140	3/4"
	GT-D122-1"1/4"-Rp1"1/4	RP 32 - 1"1/4	335	62	150	160	1"1/4
	GT-D124-1"1/2"-Rp1"1/2	RP 40 - 1"1/2	400	50	150	175	1"1/2

### ● P1.40 ... P2.250

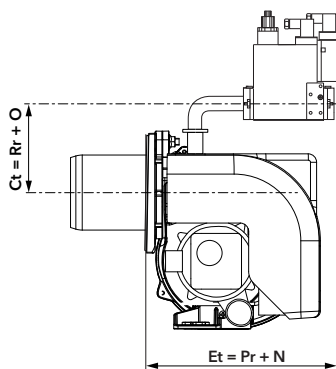

### ● P3.350 ... P3.500

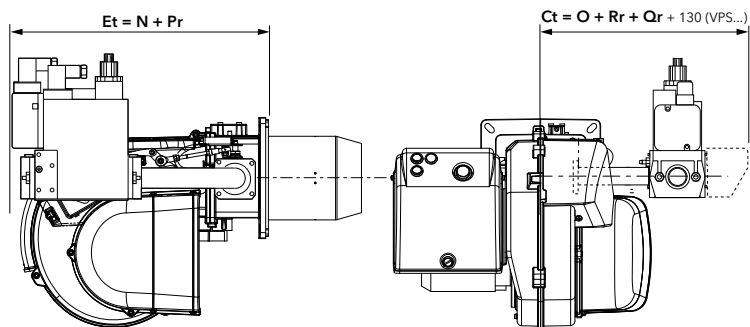

In order to calculate the total overall dimension with gas train, make reference to page 11 for dimensions **N** and **O**.  
If the sum **Pr+N** is lower than the maximum overall of the burner, **Et** dimension will be equal to **E**.

# GAS TRAINS

## Matching

### ● GUN BURNERS

Model	Gas train	Type	Pmin (mbar)	Pmax (mbar)	Max power (kW)
P1.40 G	3/8"	MB-DLE 403 B01S20	9	200	48
	1/2"	MBC 65 DLE S20	9	65	48
	3/4" (TC)	MB-DLE 407 B01S22	9	360	48
P1.70 G	3/8"	MB-DLE 403 B01S20	18	200	70
	1/2"	MBC 65 DLE S20	16	65	70
	3/4" (TC)	MB-DLE 407 B01S22	16	360	70
P1.105 G	3/4"	MBC 120 DLE S20	18	360	108
P2.130 G	3/4"	MBC 120 DLE S20	18	360	120
P2.170 G	3/4"	MB-DLE 407 B01S50	17	360	175
P2.170 G-Z	3/4"	MB-ZRDLE 407 B01S20	17	360	175
P2.250 G	3/4"	MB-DLE 407 B01S50	26	360	240
	1"1/4	MB-DLE 412 B01S20	15	360	240
P2.250 G-Z	3/4"	MB-ZRDLE 407 B01S20	26	360	240
	1"1/4	MB-ZRDLE 412 B01S50	15	360	240
P3.350 G P3.350 G-Z	3/4"	MB-DLE 407 B01S50	60	360	350
	1"1/4	MB-DLE 412 B01S20	20	360	350
	1"1/2	MB-DLE 415 B01S20	17	360	350
P3.500 G P3.500 G-Z	3/4"	MB-DLE 407 B01S50	90	360	500
	1"1/4	MB-DLE 412 B01S20	35	360	500
	1"1/2	MB-DLE 415 B01S20	20	360	500

### ■ CUBIC BURNERS

Model	Gas train	Type	Pmin (mbar)	Pmax (mbar)	Max power (kW)
P2.70 G	3/4"	MB-DLE 407 B01S20	20	300	70
P2.70 G-Z	3/4"	MB-ZRDLE 407 B01S20	20	300	70
P2.120 G	3/4"	MB-DLE 407 B01S20	20	300	120
P2.120 G-Z	3/4"	MB-ZRDLE 407 B01S20	20	300	120
P2.160 G	3/4"	MB-DLE 407 B01S20	20	300	160
P2.160 G-Z	3/4"	MB-ZRDLE 407 B01S20	20	300	160
P2.210 G	3/4"	MB-DLE 407 B01S20	20	40	180
	3/4"	MB-DLE 407 B01S20	40	300	210
	1"1/4	MB-DLE 412 B01S20	20	300	210
P2.210 G-Z	3/4"	MB-ZRDLE 407 B01S20	20	40	180
	3/4"	MB-ZRDLE 407 B01S20	40	300	210
	1"1/4	MB-ZRDLE 412 B01S20	20	300	210

## SUBSIDIARIES:

### GERMANY

Dreieichstrasse, 10  
64546 Mörfelden  
Walldorf  
Tel. +49 06 105 968 192  
Fax +49 06 105 968 199

### NETHERLANDS

Meerpaalweg, 1  
1332 BB Almere  
P.O. box 30048  
1303 AA Almere  
Tel. +31 088 69 573 11  
Fax +31 088 69 573 90

### ENGLAND

Suite 3, The Crown House  
Blackpole East,  
Blackpole Road,  
Worcester WR3 8SG  
Tel. +44 01905 788010  
Fax +44 01905 788011

### FRANCE

14, rue du Saule Trapu  
Parc d'activité du Moulin  
91882 Massy  
Tel. +33 01 60 13 64 64  
Fax +33 01 60 13 64 65

### ITALY

Viale Roma, 41  
28100 Novara  
Tel. +39 0732 633 590  
Fax +39 0732 633 599

### RUSSIA

Eniseyskaya str. 1, bld 1,  
Office Center "LIRA" #415  
129344 Moscow  
Tel. +7 495 213 0300 #5700  
Fax +7 495 213 0302

### CHINA

17A2, V-Capital Bldg  
No. 333 Xian Xia Road  
200336 Shanghai  
Tel. +86 21 6039 8691  
Fax +86 21 6039 8620

Contact us to know more  
about our products and solutions

[contact@elco-burners.com](mailto:contact@elco-burners.com)